

Design Course

Geometry in Design

Geometrical Construction in 3D Forms

by

Prof. Ravi Mokashi Punekar and

Prof. Avinash Shide

DoD, IIT Guwahati

Source:

<http://www.dsource.in/course/geometry-design>



1. Introduction
2. Golden Ratio
3. Polygon - Classification - 2D
4. Concepts - 3 Dimensional
5. Family of 3 Dimensional
6. References
7. Contact Details

Design Course

Geometry in Design

Geometrical Construction in 3D Forms
by

Prof. Ravi Mokashi Punekar and
Prof. Avinash Shide
DoD, IIT Guwahati

Source:

<http://www.dsource.in/course/geometry-design/introduction>

Introduction

Geometry is a science that deals with the study of inherent properties of form and space through examining and understanding relationships of lines, surfaces and solids. These relationships are of several kinds and are seen in forms both natural and man-made. The relationships amongst pure geometric forms possess special properties or a certain geometric order by virtue of the inherent configuration of elements that results in various forms of symmetry, proportional systems etc. These configurations have properties that hold irrespective of scale or medium used to express them and can also be arranged in a hierarchy from the totally regular to the amorphous where formal characteristics are lost.

The objectives of this course are to study these inherent properties of form and space through understanding relationships of lines, surfaces and solids. This course will enable understanding basic geometric relationships, both 2D and 3D, through a process of exploration and analysis. Concepts are supported with 3Dim visualization of models to understand the construction of the family of geometric forms and space interrelationships.

Contents:

1. Geometrical construction – Basics.
2. Golden Proportions and construction of Golden Spiral.
3. Study of Polygons.
4. Regular and Semi-regular geometric grids.
5. Platonic Solids and study of their inter-relationships.
6. Truncations of Platonic solids and Derivation of Archimedean Solids.

Materials required for Geometrical Construction of paper models:

You are encouraged to construct three dimensional paper models to understand better the concepts in geometrical construction and their inter-relationships. The following list of material will be necessary to make paper models:

1. Drawing board.
2. T-square (good quality, inexpensive plastic ones are available).
3. Transparent plastic set squares 30/60° and 45°, Size 20 cm and protractor.
4. Transparent plastic scale marked in cm and mm 50 cm. lengths.
5. Drawing instruments – compass large, bow compass, divider (fairly accurate, sturdy and inexpensive).
6. Wooden, drawing pencils in grades 2H, H, HB, B (from hard to soft).
7. Cartridge drawing paper for drawing exercises.
8. Bond paper for notes, exploratory exercises and paper folding exercises.

1. Introduction

2. Golden Ratio

3. Polygon - Classification - 2D

4. Concepts - 3 Dimensional

5. Family of 3 Dimensional

6. References

7. Contact Details

Design Course

Geometry in Design

Geometrical Construction in 3D Forms

by

Prof. Ravi Mokashi Punekar and

Prof. Avinash Shide

DoD, IIT Guwahati

Source:

<http://www.dsource.in/course/geometry-design/introduction>

9. Ivory card and box board for 3D models.

10. Metal scale to be used as cutting edge.

11. Paper cutter with blades.

12. Razor blades for sharpening pencils.

13. Erasers.

14. Tube of adhesive for model building (FEVICOL or equivalent).

15. Drawing pins or Cello-tape.



1. Introduction

2. Golden Ratio

3. Polygon - Classification - 2D

4. Concepts - 3 Dimensional

5. Family of 3 Dimensional

6. References

7. Contact Details

Design Course

Geometry in Design

Geometrical Construction in 3D Forms

by

Prof. Ravi Mokashi Punekar and

Prof. Avinash Shide

DoD, IIT Guwahati

Source:

<http://www.dsource.in/course/geometry-design/gold-en-ratio>

Golden Ratio

The Golden Ratio:

Details of the Golden Ratio are explained through below points:

1. Historical Background
2. Golden Ratio
3. Construction of Golden Rectangle
4. Examples of Golden Ratio

1. Historical Background:

In **mathematics** and the **arts**, two quantities are in the golden ratio if the **ratio** of the sum of the quantities to the larger quantity is **equal to** the ratio of the larger quantity to the smaller one. Expressed algebraically:



$$\frac{a + b}{a} = \frac{a}{b} \equiv \varphi,$$

where the Greek letter **phi** (φ) represents the golden ratio. Its value is:

$$\varphi = \frac{1 + \sqrt{5}}{2} = 1.6180339887\dots$$

1. Introduction

2. **Golden Ratio**

3. Polygon - Classification - 2D

4. Concepts - 3 Dimensional

5. Family of 3 Dimensional

6. References

7. Contact Details

Design Course

Geometry in Design

Geometrical Construction in 3D Forms

by

Prof. Ravi Mokashi Punekar and

Prof. Avinash Shide

DoD, IIT Guwahati

Source:

<http://www.dsource.in/course/geometry-design/golden-ratio>

The golden ratio, or phi, was first understood and used by the ancient mathematicians in Egypt, two to three thousand years ago, due to its frequent appearance in Geometry. Phidias (500BC-432 BC), a Greek sculptor and mathematician, studied Phi and used it in many designs of his sculptures, such as the statue of the goddess Athena in Athena, and the state of god Zeus in Olympiad. In the Elements, the most influential mathematics textbook ever written, Euclid of Alexandria (ca. 300 BC) defines a proportion derived from a division of a line into what he calls its “extreme and mean ratio.” Euclid’s definition reads:

A straight line is said to have been cut in extreme and mean ratio when, as the whole line is to the greater segment, so is the greater to the lesser.

In other words, in the diagram below, point C divides the line in such a way that the ratio of AC to CB is equal to the ratio of AB to AC.

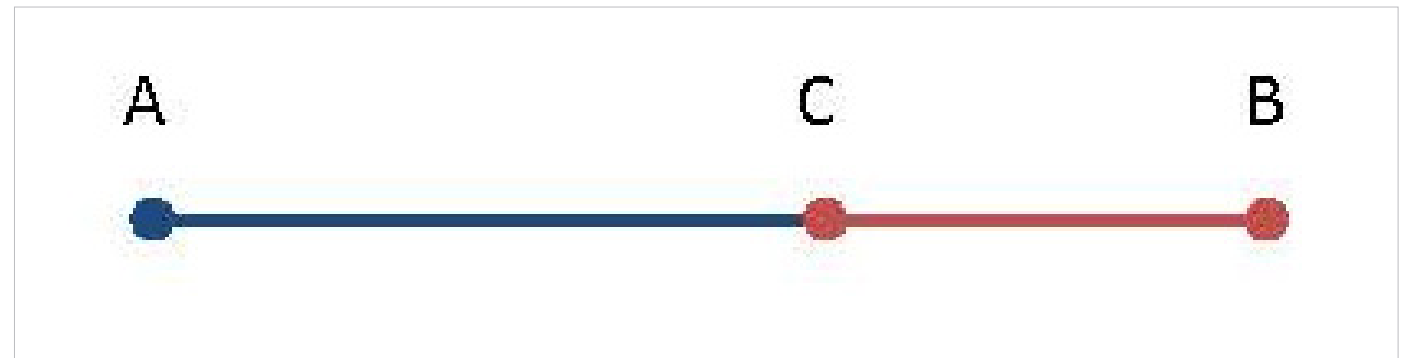

The name “Golden Ratio” appears in the form section area (Golden Section in Greek) by Leonardo da Vinci (1452-1519) who used this Golden ratio in many of his masterpieces, such as The Last Supper and Mona Lisa.

In 1900s, a Maerican mathematician named Mark Barr represented the Golden Ratio by using a Greek symbol ϕ (phi).

1. Introduction

2. **Golden Ratio**

3. Polygon - Classification - 2D

4. Concepts - 3 Dimensional

5. Family of 3 Dimensional

6. References

7. Contact Details

Design Course

Geometry in Design

Geometrical Construction in 3D Forms

by

Prof. Ravi Mokashi Punekar and

Prof. Avinash Shide

DoD, IIT Guwahati

Source:

<http://www.dsource.in/course/geometry-design/golden-ratio>

1. Introduction

2. **Golden Ratio**

3. Polygon - Classification - 2D

4. Concepts - 3 Dimensional

5. Family of 3 Dimensional

6. References

7. Contact Details

2. Golden Ratio:

The golden ratio is obtained by dividing any term of the Fibonacci sequence by its preceding number. It has a value approximately equal to 1.618 and is also known by terms as golden section, golden mean, extreme and mean ratio, medial section, divine proportion, divine section, golden proportion, golden cut, golden number, mean of **Phidias** etc.

The geometric spiral and the geometric rectangle are two of the most important constructs derived from the golden ratio. A golden rectangle has its height and width in the golden ratio whereas a golden spiral is a **logarithmic spiral** whose growth factor is the golden ratio. Other important constructs are the golden triangle and golden ellipse. The golden triangle is an isosceles triangle with an angle of 36 degrees at the vertex and base angles equal to 72 degrees each.

3. Construction of Golden Rectangle:

- 3a - Using Square Construction Method
- 3b - Using Triangle Construction Method

• 3a. Using Square Construction Method:

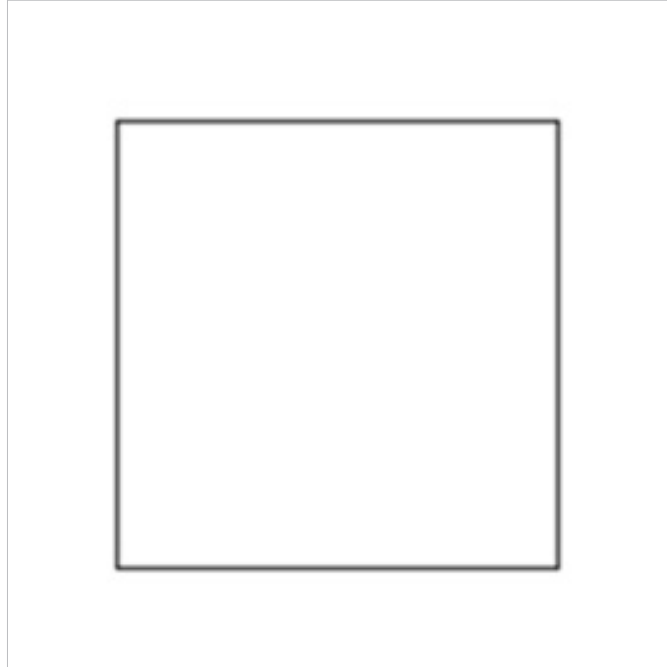

1. Draw a square

Design Course

Geometry in Design

Geometrical Construction in 3D Forms

by

Prof. Ravi Mokashi Punekar and

Prof. Avinash Shide

DoD, IIT Guwahati

Source:

<http://www.dsource.in/course/geometry-design/golden-ratio>

1. Introduction

2. **Golden Ratio**

3. Polygon - Classification - 2D

4. Concepts - 3 Dimensional

5. Family of 3 Dimensional

6. References

7. Contact Details

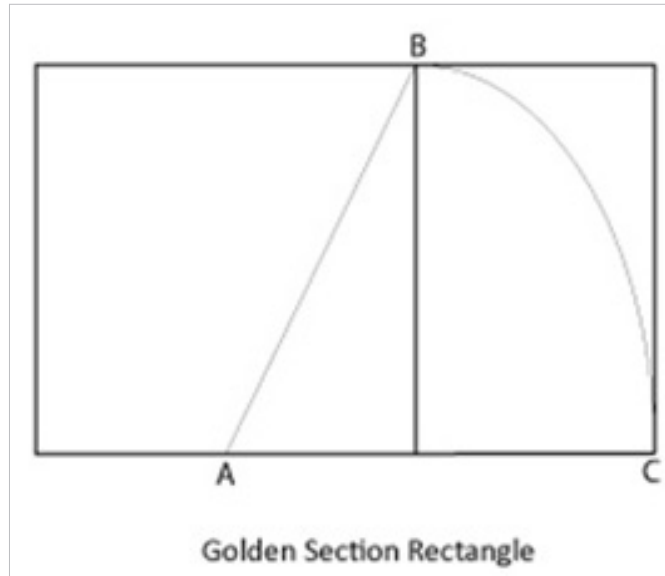

2. Draw a diagonal from mid-point A of one of the sides to an opposite corner B. With A as the centre, draw an arc to cut the side at C. Draw a perpendicular from C to get the golden rectangle.

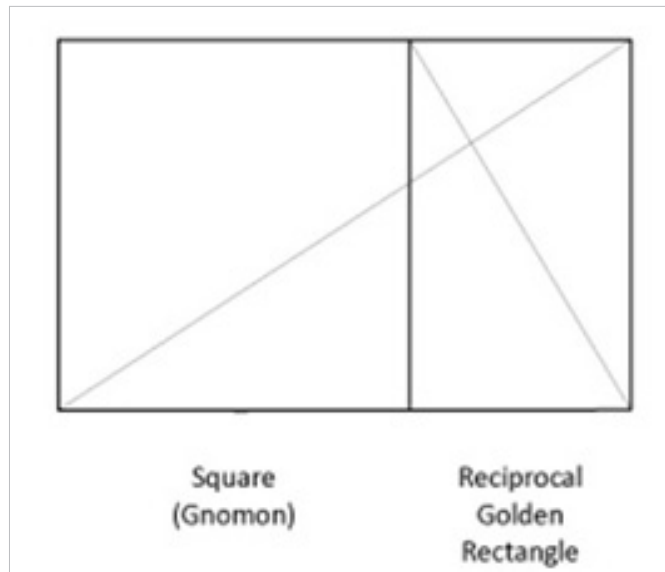

3. The golden rectangle can be subdivided as shown. When subdivided, it produces a smaller proportional golden rectangle called the reciprocal, and a square area called the gnomon remains after subdivision.

Design Course

Geometry in Design

Geometrical Construction in 3D Forms

by

Prof. Ravi Mokashi Punekar and

Prof. Avinash Shide

DoD, IIT Guwahati

Source:

<http://www.dsource.in/course/geometry-design/golden-ratio>

1. Introduction

2. **Golden Ratio**

3. Polygon - Classification - 2D

4. Concepts - 3 Dimensional

5. Family of 3 Dimensional

6. References

7. Contact Details

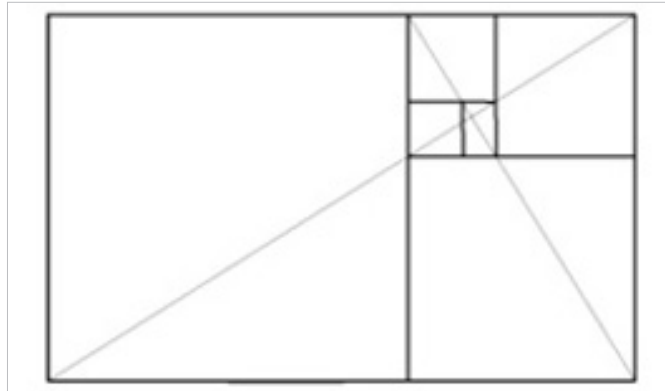

4. The process of subdivision can go on, producing smaller proportional rectangles and squares.

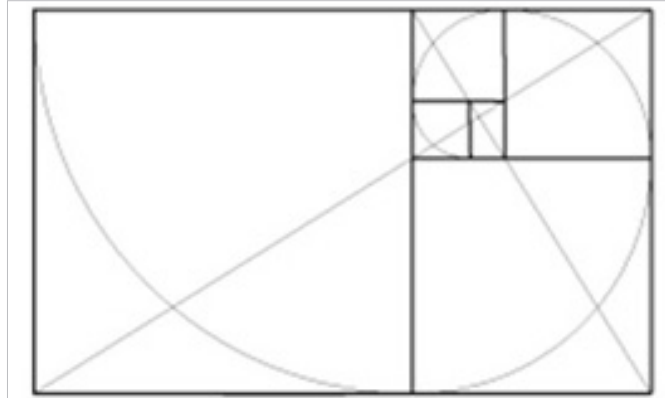

5. The proportionally decreasing squares can further produce a spiral by using a radius equal to the length of the sides of the square.

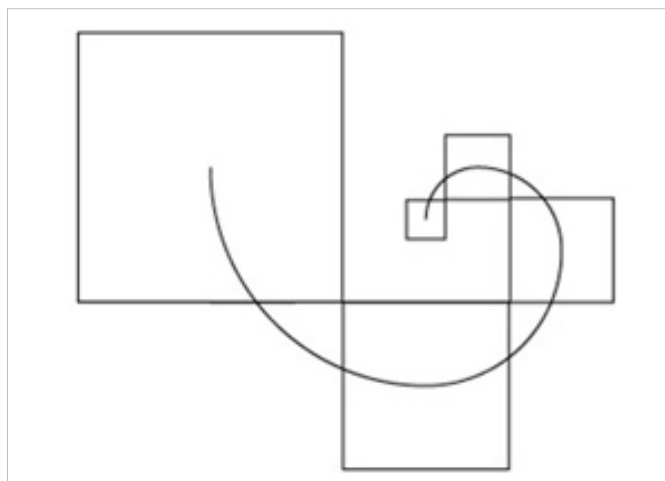

6. The squares from the golden section subdivision are also in golden proportion to each other.

Design Course

Geometry in Design

Geometrical Construction in 3D Forms

by

Prof. Ravi Mokashi Punekar and

Prof. Avinash Shide

DoD, IIT Guwahati

Source:

<http://www.dsource.in/course/geometry-design/gold-en-ratio>

1. Introduction

2. **Golden Ratio**

3. Polygon - Classification - 2D

4. Concepts - 3 Dimensional

5. Family of 3 Dimensional

6. References

7. Contact Details

• 3b. Using Triangle Construction Method:

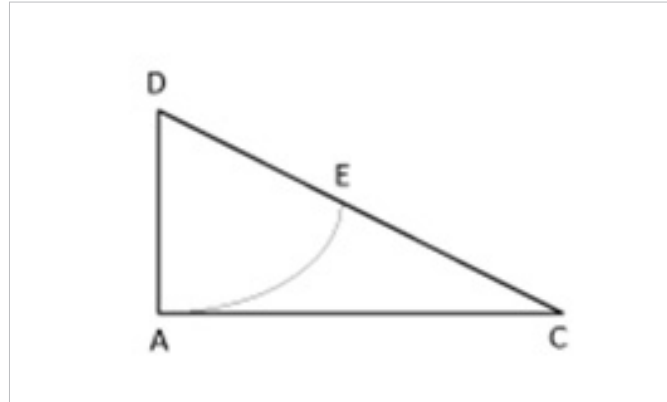

1. Draw a right triangle whose sides are in the ratio 1:2. Using D as centre and DA as radius, draw an arc that cuts the hypotenuse at E.

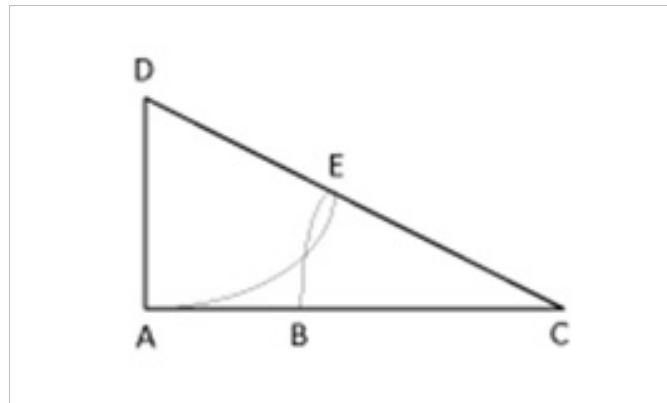

2. With C as centre and CE as radius, draw another arc that cuts AC at B.

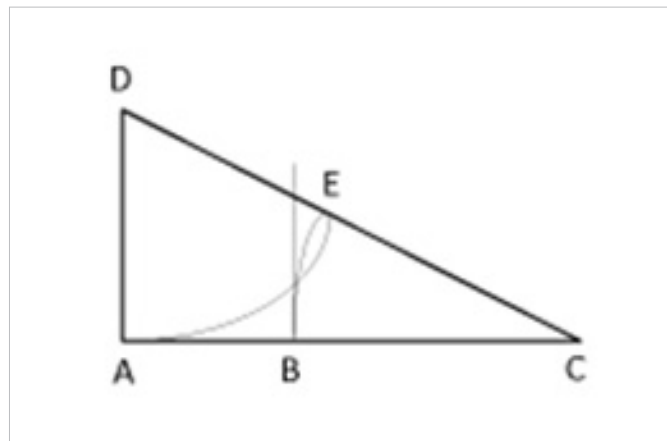

3. From B, draw a perpendicular to DC.

Design Course

Geometry in Design

Geometrical Construction in 3D Forms

by

Prof. Ravi Mokashi Punekar and

Prof. Avinash Shide

DoD, IIT Guwahati

Source:

<http://www.dsource.in/course/geometry-design/golden-ratio>

1. Introduction
2. **Golden Ratio**
3. Polygon - Classification - 2D
4. Concepts - 3 Dimensional
5. Family of 3 Dimensional
6. References
7. Contact Details

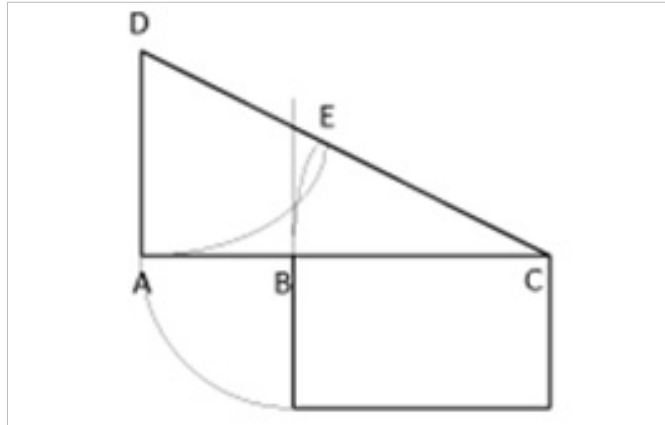

4. AB and BC are in the golden proportions and the subdivision of the triangle yields sides of a rectangle in golden ratio proportion.

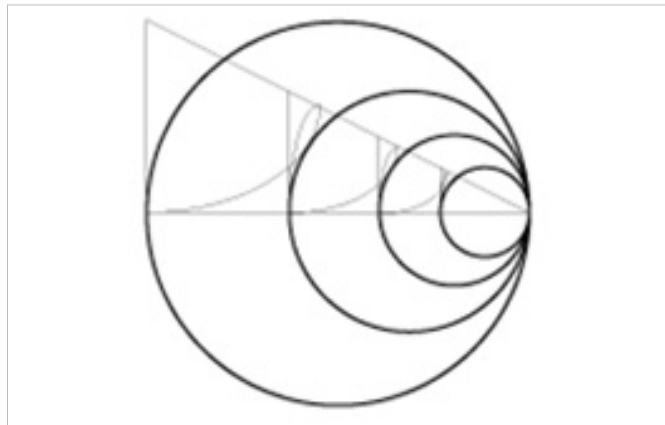

Apart from the golden rectangle, the triangle construction method produces a series of circles and squares that are in golden section proportion to each other.



Apart from the golden rectangle, the triangle construction method produces a series of circles and squares that are in golden section proportion to each other.

Design Course

Geometry in Design

Geometrical Construction in 3D Forms

by

Prof. Ravi Mokashi Punekar and

Prof. Avinash Shide

DoD, IIT Guwahati

Source:

<http://www.dsource.in/course/geometry-design/gold-en-ratio>

4. Examples of Golden Ratio:

- 4a - In Nature
- 4b - In the Human Body
- 4c - In Art and Architecture
- 4d - In Music

• 4a. In Nature:

If one looks at the array of seeds in the center of a sunflower, he can notice what looks like spiral patterns curving left and right. Amazingly, on counting these spirals, the total will be a Fibonacci number. Dividing the spirals into those pointed left and right, we'll get two consecutive Fibonacci numbers. Similar spiral patterns in pinecones, pineapples and cauliflower that also reflect the Fibonacci sequence can be deciphered in this manner.



Romansco Cauliflower
(Source: science.howstuffworks.com)



Head of a Sunflower
(Source: hynesva.com)

1. Introduction

2. **Golden Ratio**

3. Polygon - Classification - 2D

4. Concepts - 3 Dimensional

5. Family of 3 Dimensional

6. References

7. Contact Details

Design Course

Geometry in Design

Geometrical Construction in 3D Forms

by

Prof. Ravi Mokashi Punekar and

Prof. Avinash Shide

DoD, IIT Guwahati

Source:

<http://www.dsource.in/course/geometry-design/golden-ratio>

Below are images of cross-sections of a Nautilus sea shell. They show the spiral curve of the shell and the internal chambers that the animal using it adds on as it grows. The chambers provide buoyancy in the water.



Cross-section reveals golden spiral
(Source: asal-sakti.blogspot.com)



Nautilus Shell
(Source: amazingdata.com)

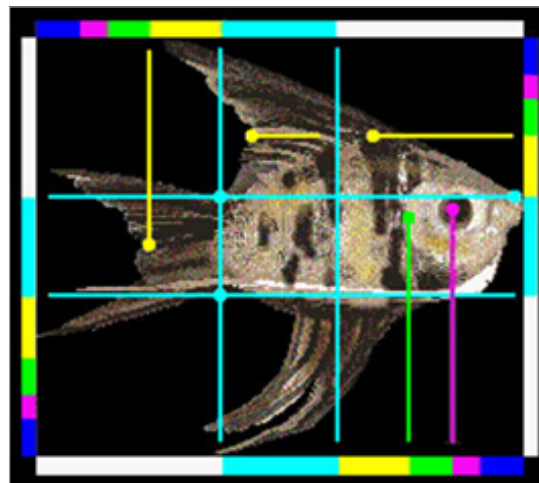

Angel Fish Every key body feature of the angel fish falls at golden sections of its width and length. The nose, tail section, and centers of the fins of the angel fish fall at first (blue) golden sections. The second golden section (yellow) defines the indents on the dorsal and tail fins as well as the top of the body. The green section defines the marking around the eye and the magenta section defines the eye. (Source: goldennumber.net)

1. Introduction

2. **Golden Ratio**

3. Polygon - Classification - 2D

4. Concepts - 3 Dimensional

5. Family of 3 Dimensional

6. References

7. Contact Details

Design Course

Geometry in Design

Geometrical Construction in 3D Forms

by

Prof. Ravi Mokashi Punekar and

Prof. Avinash Shide

DoD, IIT Guwahati

Source:

<http://www.dsource.in/course/geometry-design/golden-ratio>

1. Introduction
2. **Golden Ratio**
3. Polygon - Classification - 2D
4. Concepts - 3 Dimensional
5. Family of 3 Dimensional
6. References
7. Contact Details



Some plants express the Fibonacci sequence in their growth points, the places where tree branches form or split. One trunk grows until it produces a branch, resulting in two growth points. The main trunk then produces another branch, resulting in three growth points. Then the trunk and the first branch produce two more growth points, bringing the total to five. This pattern continues, following the Fibonacci numbers.
(Source: journalofcosmology.com)

• 4b. In the Human Body:

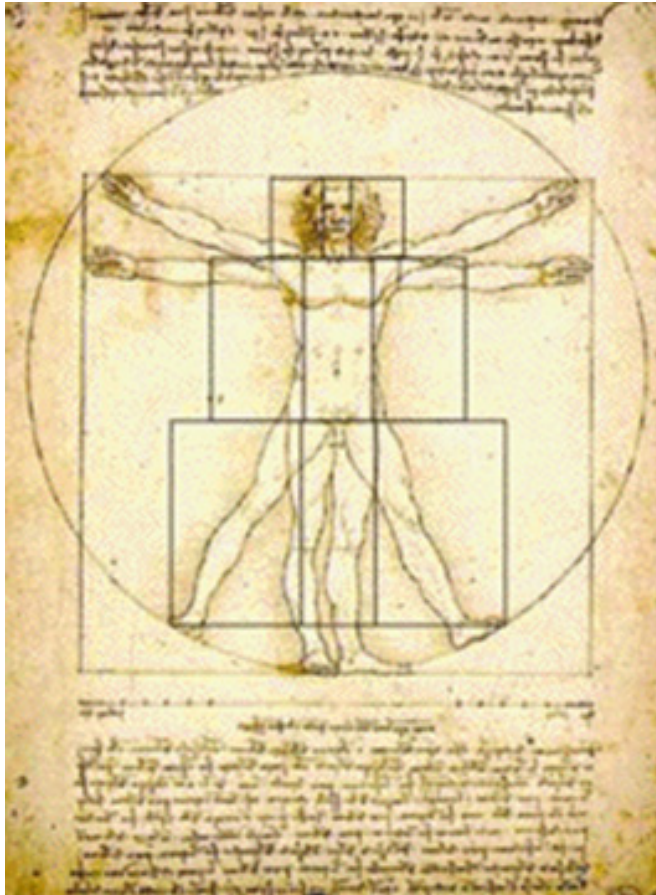

The Vitruvian Man is a world-renowned **drawing** created by **Leonardo da Vinci** circa 1487. A square encloses the body while the hands and feet touch a circle with the navel as center. The figure is divided in half at the groin, and by the golden section at the navel. The drawing is based on the correlations of ideal **human proportions** with geometry described by the ancient Roman architect **Vitruvius** in Book III of his treatise **De Architectura**.
(Source: sistertongue.wordpress.com)

Design Course

Geometry in Design

Geometrical Construction in 3D Forms

by

Prof. Ravi Mokashi Punekar and

Prof. Avinash Shide

DoD, IIT Guwahati

Source:

<http://www.dsource.in/course/geometry-design/golden-ratio>

From the illustration given below, we can see several occurrences of the golden ratio found in the **human body**.

1. Sole to navel: Sole to crown.
2. Sole to knee: Sole to navel.
3. Navel to shoulder: Navel to crown.
4. Knee to calf-muscle: Knee to sole.
5. Navel to mid-thigh: Navel to knee.
6. Navel to mid-chest: Navel to base of throat.
7. Base of throat to temple: Base of throat to crown.
8. Calf muscle to ankle: Calf muscle to sole.
9. Mid-thigh to start of kneecap: Mid-thigh to end of kneecap.
10. Navel to crotch: Navel to mid-thigh.
11. Navel to sternum base: Navel to sternum or mid-chest.
12. Base of throat to earlobe: Base of throat to top of ear.
13. Brow bone to hairline: Brow bone to crown.
14. Nose to chin: Nose to base of throat

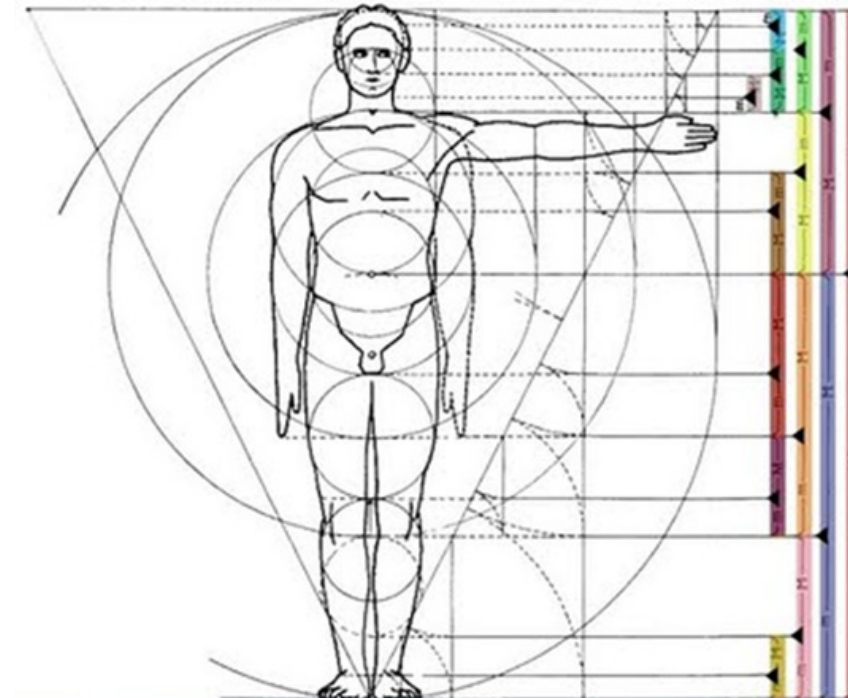

(Source: beautifulproportion.com)

1. Introduction

2. **Golden Ratio**

3. Polygon - Classification - 2D

4. Concepts - 3 Dimensional

5. Family of 3 Dimensional

6. References

7. Contact Details

Design Course

Geometry in Design

Geometrical Construction in 3D Forms

by

Prof. Ravi Mokashi Punekar and

Prof. Avinash Shide

DoD, IIT Guwahati

Source:

<http://www.dsource.in/course/geometry-design/golden-ratio>

1. Introduction
2. **Golden Ratio**
3. Polygon - Classification - 2D
4. Concepts - 3 Dimensional
5. Family of 3 Dimensional
6. References
7. Contact Details

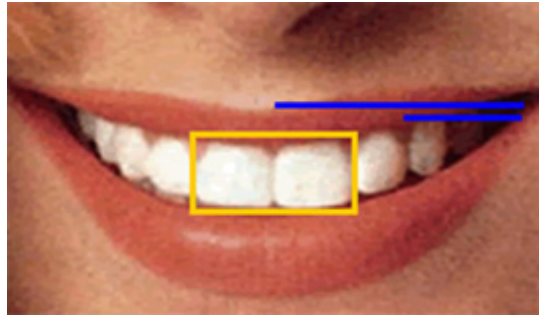

For a perfect smile, the front two teeth form a golden rectangle. There is also a golden ratio in the height to width of the center two teeth. And the ratio of the width of the two center teeth to those next to them is phi. The ratio of the width of the smile to the third tooth from the center is also phi. (Source: library.thinkquest.org)

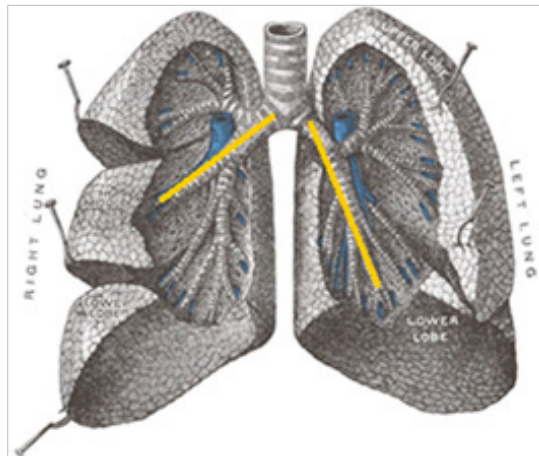

In the human lungs, the windpipe divides into two main bronchi, one long (the left) and the other short (the right). This asymmetrical division continues into the subsequent subdivisions of the bronchi. It was determined that in all these divisions the proportion of the short bronchus to the long was always $1/1.618$. (Source: library.thinkquest.org)

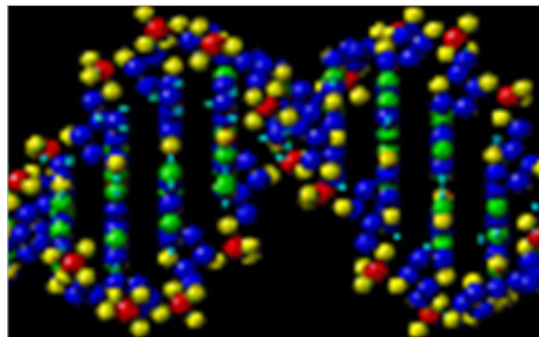

Even the DNA molecule, the program for all life, is based on the Golden section. It measures 34 angstroms long by 21 angstroms wide for each full cycle of its double helix spiral. 34 and 21, of course, are numbers in the Fibonacci series and their ratio, 1.6190476 closely approximates Phi, 1.6180339. (Source: sites.google.com/site/chsscience/)

Design Course

Geometry in Design

Geometrical Construction in 3D Forms

by

Prof. Ravi Mokashi Punekar and

Prof. Avinash Shide

DoD, IIT Guwahati

Source:

<http://www.dsource.in/course/geometry-design/golden-ratio>

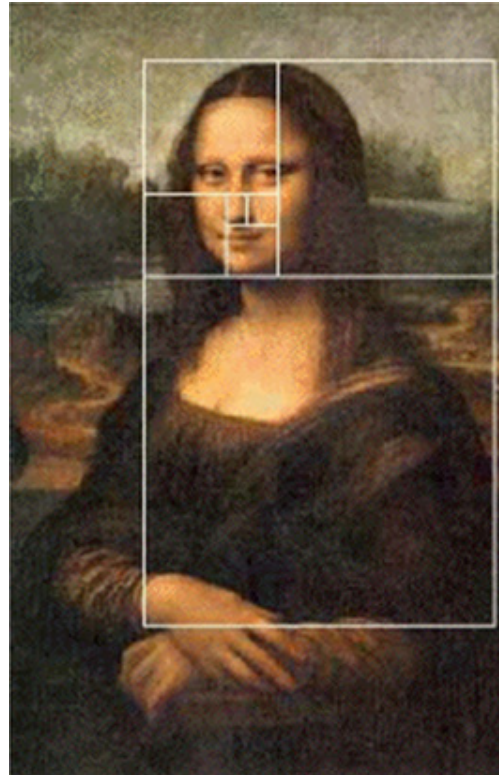

Mona-Lisa by Leonardo da Vinci
(Source: sinearch.com)



Holy Family by Micahelangelo
The principal figures are in alignment with a pentagram or golden star.
(Source: fabulousfibonacci.com)

1. Introduction
2. **Golden Ratio**
3. Polygon - Classification - 2D
4. Concepts - 3 Dimensional
5. Family of 3 Dimensional
6. References
7. Contact Details

Design Course

Geometry in Design

Geometrical Construction in 3D Forms

by

Prof. Ravi Mokashi Punekar and

Prof. Avinash Shide

DoD, IIT Guwahati

Source:

<http://www.dsource.in/course/geometry-design/gold-en-ratio>



Self-portrait by Rembrandt

The triangle cuts the base in the golden section.
(Source: jwilson.coe.uga.edu)



The sacrament of the Last Supper

-by Salvador Dali

The picture is painted inside a golden rectangle.
(Source: goldennumber.net)



Parthenon

(Source: britton.disted.camosun.bc.ca)

1. Introduction

2. **Golden Ratio**

3. Polygon - Classification - 2D

4. Concepts - 3 Dimensional

5. Family of 3 Dimensional

6. References

7. Contact Details

Design Course

Geometry in Design

Geometrical Construction in 3D Forms

by

Prof. Ravi Mokashi Punekar and

Prof. Avinash Shide

DoD, IIT Guwahati

Source:

<http://www.dsource.in/course/geometry-design/golden-ratio>

1. Introduction

2. **Golden Ratio**

3. Polygon - Classification - 2D

4. Concepts - 3 Dimensional

5. Family of 3 Dimensional

6. References

7. Contact Details

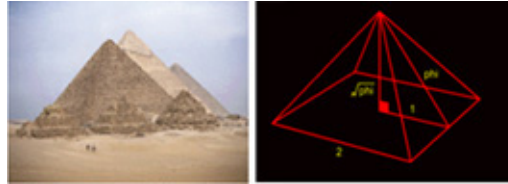

The Great Pyramid of Giza
(Source: jwilson.coe.uga.edu)

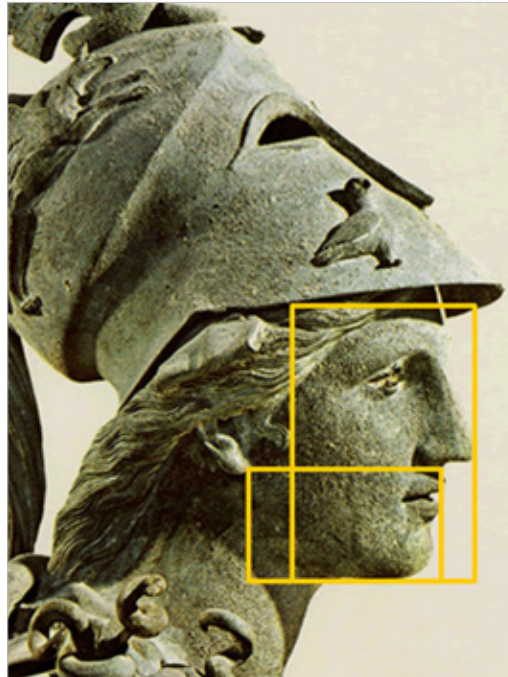

Statue of Athena
(Source: library.thinkquest.org)

• 4d. In Music:

In addition to existing in nature, art and architecture, it has been hypothesized that great classical composers like Mozart had an awareness of the Golden Ratio and used it to compose some of his famous sonatas. The Golden Ratio appears in the relationship of the intervals or distance between the notes. Musical scales are based on Fibonacci numbers. There are 13 notes in the span of any note through its octave. A scale is comprised of 8 notes, of which the 5th and 3rd notes create the basic foundation of all chords, and are based on whole tone which is 2 steps from the root tone, that is the 1st note of the scale.

Design Course

Geometry in Design

Geometrical Construction in 3D Forms

by

Prof. Ravi Mokashi Punekar and

Prof. Avinash Shide

DoD, IIT Guwahati

Source:

<http://www.dsource.in/course/geometry-design/polygon-classification-2d>

Polygon - Classification - 2D

Polygon and their Classification:

1. Polygon – Definition
2. Classification of Polygons
3. Properties of Polygons
4. Naming polygons
5. Generalizations of polygons
6. Tessellation

1. Polygon – Definition:

The word “polygon” comes from **Late Latin** polygōnum (a noun), from **Greek** polygōnon/polugōnon, meaning “many-angled”.

2. Classification of Polygons:

- 2a. Polygons Based on Number of sides
- 2b. Polygon Based on Convexity and types of non-convexity
- 2c. Polygon Based on Nature of Symmetry
- 2d. Miscellaneous

Shown below are graphical representations of the different kinds of Polygons that can be classified based on a set (or combinations thereof) of criteria. These can be classified as: Simple; Convex and Non-convex; Cyclic; Equilateral and Equiangular; Regular etc. The criteria for classifications are highlighted below.

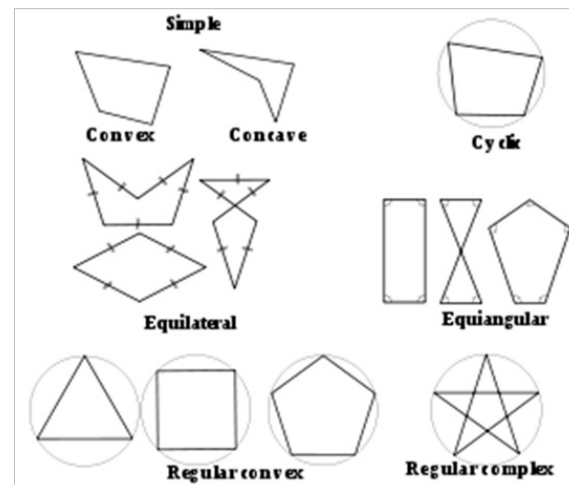

1. Introduction

2. Golden Ratio

3. Polygon - Classification - 2D

4. Concepts - 3 Dimensional

5. Family of 3 Dimensional

6. References

7. Contact Details

Design Course

Geometry in Design

Geometrical Construction in 3D Forms

by

Prof. Ravi Mokashi Punekar and

Prof. Avinash Shide

DoD, IIT Guwahati

Source:

<http://www.dsource.in/course/geometry-design/polygon-classification-2d>

1. Introduction

2. Golden Ratio

3. **Polygon - Classification - 2D**

4. Concepts - 3 Dimensional

5. Family of 3 Dimensional

6. References

7. Contact Details

• 2a. Polygons Based on Number of sides:

Polygons are primarily classified by the number of sides.

For Eg. Trigon, Tetragon, Pentagon, Hexagon, Octagon etc. There is an order in naming polygons and this is outlined in the section Naming Polygons.

• 2b. Polygon Based on Convexity and types of non-convexity:

Polygons may be characterised by their convexity or type of non-convexity:

(1) Convex: Any line drawn through the polygon (and not tangent to an edge or corner) meets its boundary exactly twice. Equivalently, all its interior angles are less than 180° .

(2) Non-convex: A line may be found which meets its boundary more than twice. In other words, it contains at least one interior angle with a measure larger than 180° .

(3) Simple: The boundary of the polygon does not cross itself. All convex polygons are simple.

(4) Concave: Non-convex and simple.

(5) Star Shaped: The whole interior is visible from a single point, without crossing any edge. The polygon must be simple, and may be convex or concave.

(6) Self-intersecting: The boundary of the polygon crosses itself.

(7) Star Polygon: A polygon which self-intersects in a regular way.

• 2c. Polygon Based on Nature of Symmetry:

(1) Equiangular: All its corner angles are equal.

(2) Cyclic: All corners lie on a single circle.

(3) Isogonal or vertex-transitive: All corners lie within the same symmetry orbit. The polygon is also cyclic and equiangular.

(4) Equilateral: All edges are of the same length. (A polygon with 5 or more sides can be equilateral without being convex)

(5) Isotoxal or edge-transitive: All sides lie within the same symmetry orbit. The polygon is also equilateral.

(6) Regular: A polygon is regular if it is both cyclic and equilateral. A non-convex regular polygon is called a regular star polygon.

Design Course

Geometry in Design

Geometrical Construction in 3D Forms

by

Prof. Ravi Mokashi Punekar and

Prof. Avinash Shide

DoD, IIT Guwahati

Source:

<http://www.dsource.in/course/geometry-design/polygon-classification-2d>

1. Introduction

2. Golden Ratio

3. Polygon - Classification - 2D

4. Concepts - 3 Dimensional

5. Family of 3 Dimensional

6. References

7. Contact Details

• 2d. Miscellaneous:

(1) Rectilinear: A polygon whose sides meet at right angles, i.e., all its interior angles are 90 or 270 degrees.

(2) Monotone: With respect to a given line L, if every line orthogonal to L intersects the polygon not more than twice.

3. Properties of Polygons:

These are based on Euclidean geometry assumptions.

- 3a. Angles
- 3b. Self-intersecting polygons
- 3c. Degrees of freedom
- 3d. Product of diagonals of a regular polygon

• 3a. Angles:

Any polygon, regular or irregular, self-intersecting or simple, has as many corners as it has sides. Each corner has several angles. The two most important ones are:

(1) Interior Angle:

The sum of the interior angles of a simple n-gon is $(n - 2)$ radians or $(n - 2)180$ degrees. This is because any simple n-gon can be considered to be made up of $(n - 2)$ triangles, each of which has an angle sum of π radians or 180 degrees. The measure of any interior angle of a convex regular n-gon is radians or $(180 -)$ degrees. The interior angles of regular star polygons were first studied by Poincot, in the same paper in which he describes the four regular star polyhedra.

(2) Exterior Angle:

Tracing around a convex n-gon, the angle “turned” at a corner is the exterior or external angle. Tracing all the way round the polygon makes one full turn, so the sum of the exterior angles must be 360° . This argument can be generalized to concave simple polygons, if external angles that turn in the opposite direction are subtracted from the total turned. Tracing around an n-gon in general, the sum of the exterior angles (the total amount one rotates at the vertices) can be any integer multiple d of 360° , e.g. 720° for a pentagram and 0° for an angular “eight”, where d is the density or starriness of the polygon.

The exterior angle is the supplementary angle to the interior angle. From this the sum of the interior angles can be easily confirmed, even if some interior angles are more than 180° : going clockwise around, it means that one sometime turns left instead of right, which is counted as turning a negative amount. (Thus we consider something like the winding number of the orientation of the sides, where at every vertex the contribution is between $-\frac{1}{2}$ and $\frac{1}{2}$ winding.)

Design Course

Geometry in Design

Geometrical Construction in 3D Forms

by

Prof. Ravi Mokashi Punekar and

Prof. Avinash Shide

DoD, IIT Guwahati

Source:

<http://www.dsource.in/course/geometry-design/polygon-classification-2d>

1. Introduction

2. Golden Ratio

3. Polygon - Classification - 2D

4. Concepts - 3 Dimensional

5. Family of 3 Dimensional

6. References

7. Contact Details

• 3b. Self-intersecting polygons:

The area of a self-intersecting polygon can be defined in two different ways, each of which gives a different answer:

- Using the above methods for simple polygons, we discover that particular regions within the polygon may have their area multiplied by a factor which we call the density of the region. For example the central convex pentagon in the centre of a pentagram has density 2. The two triangular regions of a cross-quadrilateral (like a figure 8) have opposite-signed densities, and adding their areas together can give a total area of zero for the whole figure.

- Considering the enclosed regions as point sets, we can find the area of the enclosed point set. This corresponds to the area of the plane covered by the polygon, or to the area of a simple polygon having the same outline as the self-intersecting one (or, in the case of the cross-quadrilateral, the two simple triangles).

• 3c. Degrees of freedom:

An n -gon has $2n$ degree of freedom, including 2 for position, 1 for rotational orientation, and 1 for over-all size, so $2n - 4$ for shape. In the case of a line of symmetry the latter reduces to $n - 2$.

Let $k \geq 2$. For an nk -gon with k -fold rotational symmetry (C_k), there are $2n - 2$ degrees of freedom for the shape. With additional mirror-image symmetry (D_k) there are $n - 1$ degrees of freedom.

• 3d. Product of diagonals of a regular polygon:

For a regular n -gon inscribed in a unit-radius circle, the product of the distances from a given vertex to all other vertices equals n .

4. Naming polygons:

- 4a. Constructing higher names

Individual polygons are named (and sometimes classified) according to the number of sides, combining a Greek derived numerical prefix with the suffix -gon, e.g. pentagon, dodecagon. The triangle and quadrilateral or quadrangle, and nonagon are exceptions. For large numbers, mathematicians usually write the numeral itself, e.g. 17-gon. A variable can even be used, usually n -gon. This is useful if the number of sides is used in a formula.

Design Course

Geometry in Design

Geometrical Construction in 3D Forms

by

Prof. Ravi Mokashi Punekar and

Prof. Avinash Shide

DoD, IIT Guwahati

Source:

<http://www.dsource.in/course/geometry-design/polygon-classification-2d>

1. Introduction

2. Golden Ratio

3. **Polygon - Classification - 2D**

4. Concepts - 3 Dimensional

5. Family of 3 Dimensional

6. References

7. Contact Details

Some special polygons also have their own names; for example the regular star pentagon is also known as the **pentagram**.

Below are listed names of polygons:

Name	Edges	Remarks
Henagon (or monogon)	1	In the Euclidean plane, degenerates to a closed curve with a single vertex point on it.
Digon	2	In the Euclidean plane, degenerates to a closed curve with two vertex points on it.
Triangle (or trigon)	3	The simplest polygon which can exist in the Euclidean plane.
Quadrilateral (or quadrangle or tetragon)	4	The simplest polygon which can cross itself.
Pentagon	5	The simplest polygon which can exist as a regular star. A star pentagon is known as a pentagram or pentacle.
Hexagon	6	avoid “sexagon” = Latin [sex-] + Greek Tokyo
Heptagon	7	avoid “septagon” = Latin [sept-] + Greek
Octagon	8	
Enneagon or Nonagon	9	“Nonagon” is commonly used but mixes Latin [novem = 9] with Greek. Some modern authors prefer “enneagon”.
Decagon	10	
Hendecagon	11	Avoid “undecagon” = Latin [un-] + Greek
Dodecagon	12	Avoid “duodecagon” = Latin [duo-] + Greek
Tridecagon (or triskaidecagon)	13	
Tetradecagon (or tetrakaidecagon)	14	

Design Course

Geometry in Design

Geometrical Construction in 3D Forms

by

Prof. Ravi Mokashi Punekar and

Prof. Avinash Shide

DoD, IIT Guwahati

Source:

<http://www.dsource.in/course/geometry-design/polygon-classification-2d>

1. Introduction

2. Golden Ratio

3. **Polygon - Classification - 2D**

4. Concepts - 3 Dimensional

5. Family of 3 Dimensional

6. References

7. Contact Details

Name	Edges	Remarks
Pentadecagon (or quindecagon or pentakaidecagon)	15	
Hexadecagon (or hexakaidecagon)	16	
Heptadecagon (or heptakaidecagon)	17	
Quadrilateral (or quadrangle or tetragon)	18	
Enneadecagon (or enneakaidecagon or nonadecagon)	19	
Icosagon	20	Oak Knoll Press
Triacontagon	30	
Hectogon	100	“Hectogon” is the Greek name, “centagon” is a Latin-Greek hybrid; neither is widely attested.
Chiliagon	1000	The measure of each angle in a regular chiliagon is 179.64°.
Myriagon	10000	The internal angle of a regular myriagon is 179.964°.
Megagon[6]	1,000,000	The internal angle of a regular megagon is 179.99964 degrees.
Apeirogon		A degenerate polygon of infinitely many sides.

Design Course

Geometry in Design

Geometrical Construction in 3D Forms

by

Prof. Ravi Mokashi Punekar and

Prof. Avinash Shide

DoD, IIT Guwahati

Source:

<http://www.dsource.in/course/geometry-design/polygon-classification-2d>

1. Introduction

2. Golden Ratio

3. **Polygon - Classification - 2D**

4. Concepts - 3 Dimensional

5. Family of 3 Dimensional

6. References

7. Contact Details

• 4a. Constructing higher names:

To construct the name of a polygon with more than 20 and less than 100 edges, combine the prefixes as follows:

	Tens	Tens		Final suffix
		1	-hena-	gon
20	Icosi-	2	-di-	gon
30	Triaconta-	3	-tri-	gon
40	Tetraconta-	4	-tetra-	gon
50	Pentaconta- kai	5	-penta-	gon
60	Hexaconta-	6	-hexa-	gon
70	Heptaconta-	7	-hepta-	gon
80	Octaconta-	8	-octa-	gon
90	Enneaconta-	9	-ennea-	gon

The “kai” is not always used. Opinions differ on exactly when it should, or need not, be used.

Design Course

Geometry in Design

Geometrical Construction in 3D Forms

by

Prof. Ravi Mokashi Punekar and

Prof. Avinash Shide

DoD, IIT Guwahati

Source:

<http://www.dsource.in/course/geometry-design/polygon-classification-2d>

1. Introduction

2. Golden Ratio

3. Polygon - Classification - 2D

4. Concepts - 3 Dimensional

5. Family of 3 Dimensional

6. References

7. Contact Details

5. Generalizations of polygons:

In a broad sense, a polygon is an unbounded (without ends) sequence or circuit of alternating segments (sides) and angles (corners). An ordinary polygon is unbounded because the sequence closes back in itself in a loop or circuit, while an infinite polygon is unbounded because it goes on forever so you can never reach any bounding end point. The modern mathematical understanding is to describe such a structural sequence in terms of an “abstract” polygon which is a **partially ordered set** (poset) of elements. The interior (body) of the polygon is another element, and (for technical reasons) so is the null polytope or nullitope.

A geometric polygon is understood to be a “realization” of the associated abstract polygon; this involves some “mapping” of elements from the abstract to the geometric. Such a polygon does not have to lie in a plane, or have straight sides, or enclose an area, and individual elements can overlap or even coincide. For example a **spherical polygon** is drawn on the surface of a sphere, and its sides are arcs of great circles. So when we talk about “polygons” we must be careful to explain what kind we are talking about.

A **digon** is a closed polygon having two sides and two corners. On the sphere, we can mark two opposing points (like the North and South poles) and join them by half a great circle. Add another arc of a different great circle and you have a digon. Tile the sphere with digons and you have **apolyhedron** called a **hosohedron**. Take just one great circle instead, run it all the way round, and add just one “corner” point, and you have a monogon or hena-gon—although many authorities do not regard this as a proper polygon.

Other realizations of these polygons are possible on other surfaces, but in the Euclidean (flat) plane, their bodies cannot be sensibly realized and we think of them as **degenerate**.

6. Tessellation:

A complete covering of a plane using a limited number of different shapes. Usually the shapes are polygons (as in the **Dirichlet tessellation**). The plane can be tessellated with rectangles, or hexagons, or triangles (for example, using **Delaunay triangles**).

In a regular tessellation all the shapes are regular polygons (i.e. with all sides equal and all angles equal) of the same shape and size, and there are only three possible regular tessellations, using squares, equilateral triangles, or regular hexagons.

Other semi-regular tessellations use two or more regular polygonal shapes, for example, squares and octagons. Many tessellations are periodic, i.e. the pattern repeats at regular intervals. A non-periodic tessellation, using two basic shapes, was invented by Sir Roger Penrose and is usually referred to as Penrose tiling.

Websites:

[Impossible world: Articles: The principles of artistic illusions](#)
[Tessellation -- from Wolfram MathWorld](#)

Design Course

Geometry in Design

Geometrical Construction in 3D Forms

by

Prof. Ravi Mokashi Punekar and

Prof. Avinash Shide

DoD, IIT Guwahati

Source:

<http://www.dsource.in/course/geometry-design/concepts-3-dimensional>

1. Introduction
2. Golden Ratio
3. Polygon - Classification - 2D
4. **Concepts - 3 Dimensional**
5. Family of 3 Dimensional
6. References
7. Contact Details

Concepts - 3 Dimensional

Geometrical construction of Solids:

Concepts in the study and understanding of 3D geometric forms are based on ideas developed by Keith Critchlow in his book 'Order in Space – A Design source book', Thames and Hudson, (1969).

He argues that the primary idea of order and number is one of the ways of understanding our universe. He proposes that the fundamental element of this cosmos is space. Since its nature is emptiness and because it is empty it can contain and embrace everything. It is therefore necessary that to understand the tangible concepts such as '3-Dimensional form' is best understand it through the perspective of space.

For example:

if we were to regard the point as physically real, then it can be visualized and seen to occupy a position in space. By manipulation one can then study its behavior singly or collectively. Based on this presumption, concepts developed in this section attempt to bring understanding to the concepts in the configurations and construction of 3 Dimensional form.

Some Definitions:

• Point:

We visualize the point to be a minute version and see what volume it describes by tracing it systematically through space. Sphere is the most suitable form to give to the 'point' as it has complete rotational symmetry and is least biased. Point can be referred to as a 'spherepoint'.

• Line:

If a point moves in an unchanging direction, from a starting position, a trace of its path is called a 'line'.

• Plane:

Moving the line in any other direction than the first direction describes the planar trace.

• Solid:

The trace of the third change in the direction describes 'solid'.

Design Course

Geometry in Design

Geometrical Construction in 3D Forms

by

Prof. Ravi Mokashi Punekar and

Prof. Avinash Shide

DoD, IIT Guwahati

Source:

<http://www.dsource.in/course/geometry-design/concepts-3-dimensional>

1. Introduction
2. Golden Ratio
3. Polygon - Classification - 2D
4. **Concepts - 3 Dimensional**
5. Family of 3 Dimensional
6. References
7. Contact Details

The economic unfolding of the dimensions of space can be visualized based on the concept of **sphere point** as shown below.

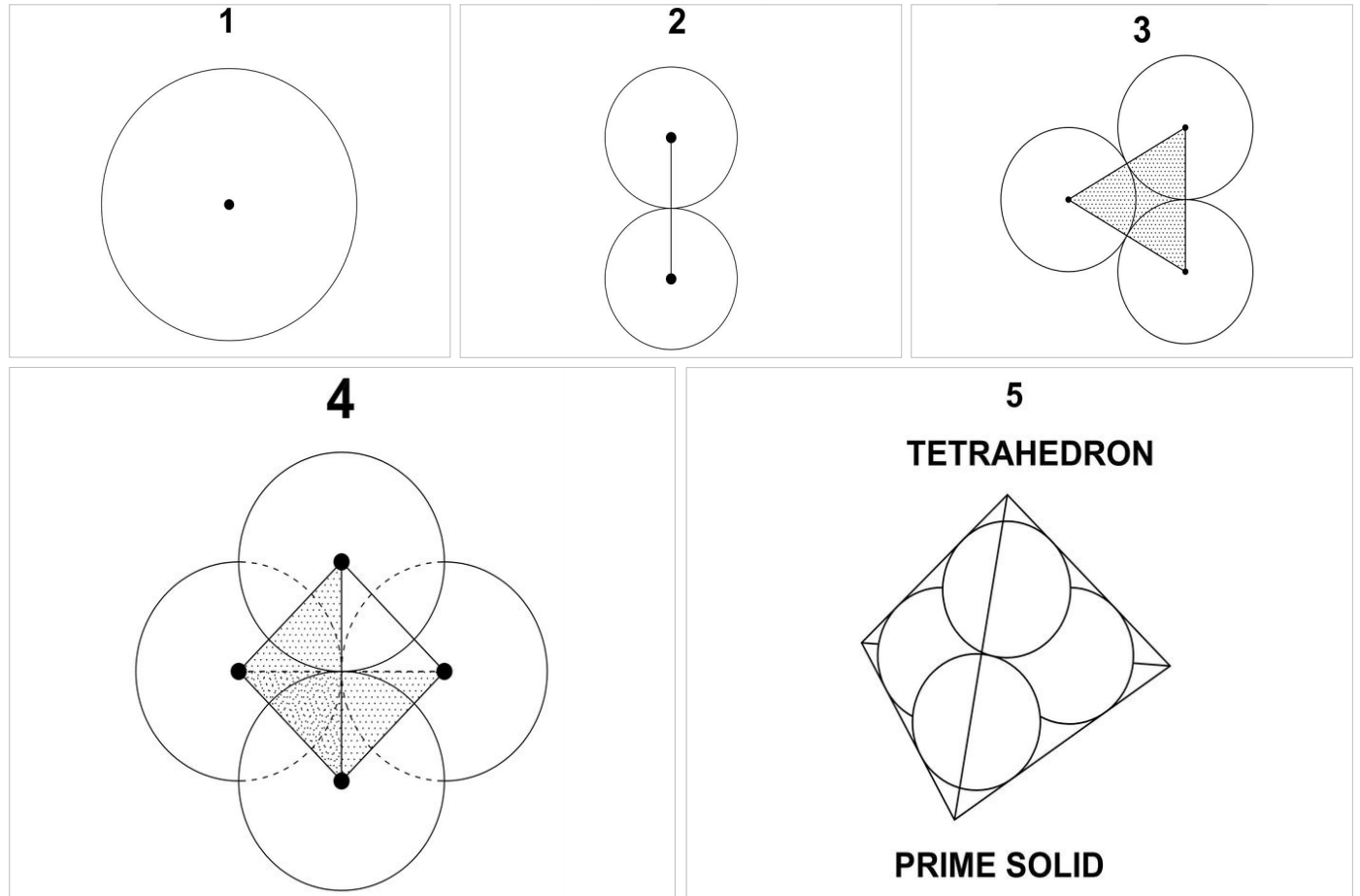

Design Course

Geometry in Design

Geometrical Construction in 3D Forms

by

Prof. Ravi Mokashi Punekar and

Prof. Avinash Shide

DoD, IIT Guwahati

Source:

<http://www.dsource.in/course/geometry-design/concepts-3-dimensional>

1. Introduction
2. Golden Ratio
3. Polygon - Classification - 2D
4. **Concepts - 3 Dimensional**
5. Family of 3 Dimensional
6. References
7. Contact Details

The economic unfolding of the dimensions of space can be visualized based on the concept of **sphere point** as shown below.

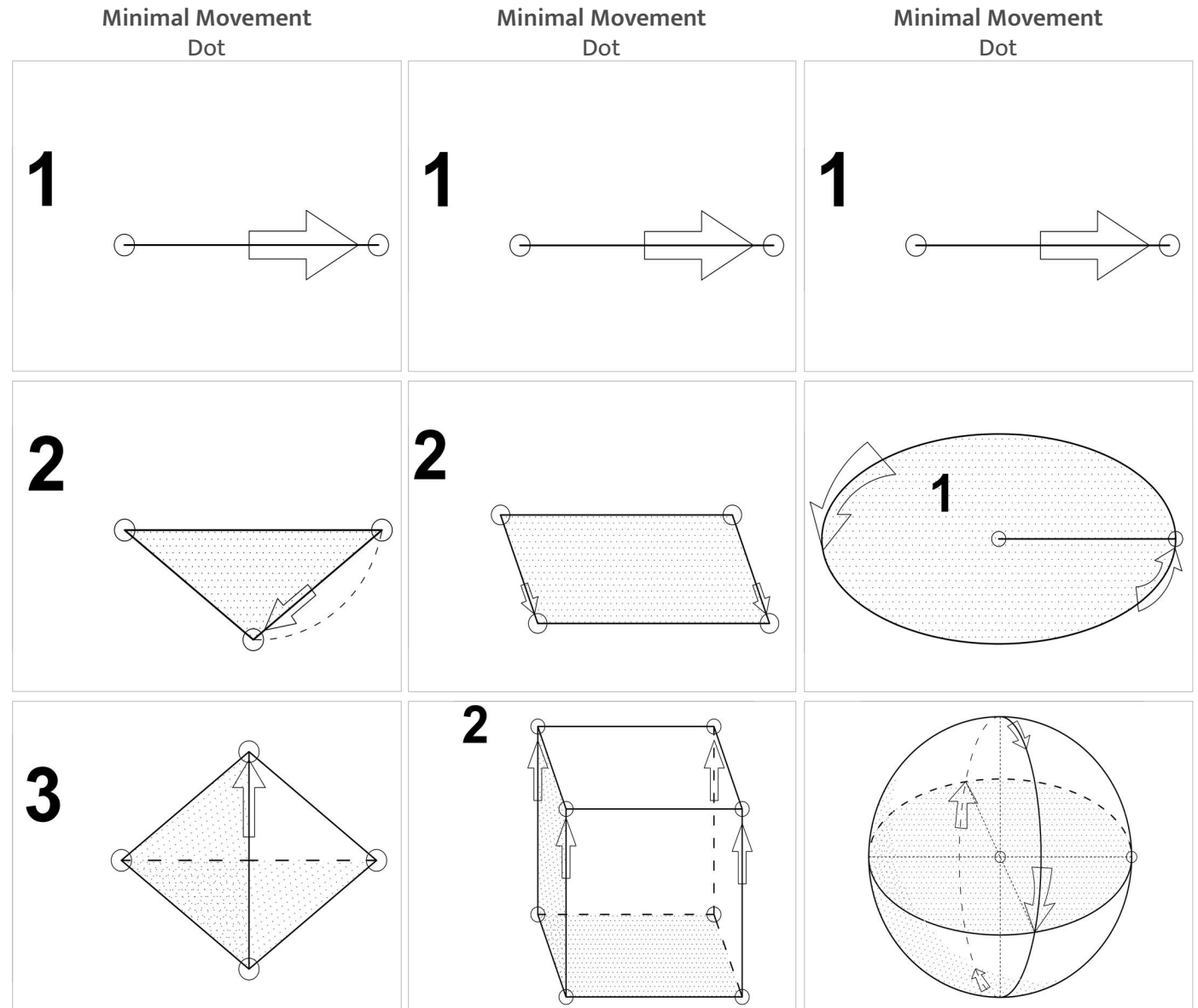

Design Course

Geometry in Design

Geometrical Construction in 3D Forms

by

Prof. Ravi Mokashi Punekar and

Prof. Avinash Shide

DoD, IIT Guwahati

Source:

<http://www.dsource.in/course/geometry-design/concepts-3-dimensional>

1. Introduction
2. Golden Ratio
3. Polygon - Classification - 2D
4. **Concepts - 3 Dimensional**
5. Family of 3 Dimensional
6. References
7. Contact Details

(1) Tetrahedron:

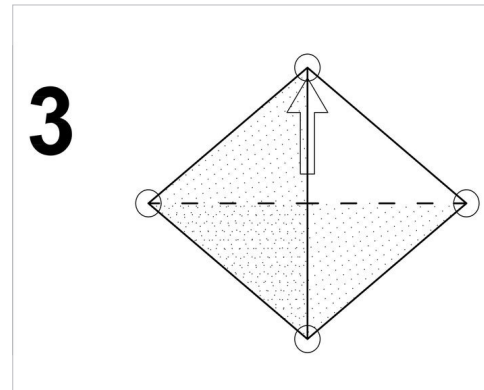

- The most economical four-faced pyramid (the solid Pyramid).
- Strongest of the solids, being most able to resist the external forces from all direction.
- It has the greatest surface area for volume of all polyhedra.

(2) Cube:

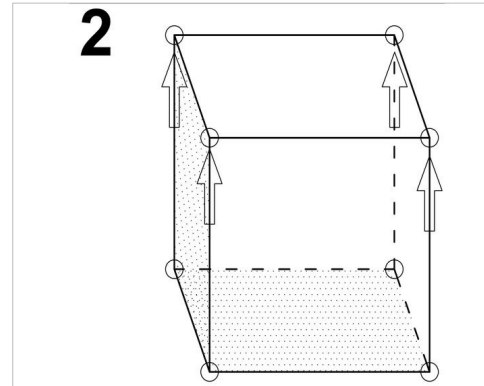

- Transitional phase between tetrahedron and sphere.
- Is a 'sociable' and close-packing unit.

(3) Sphere:

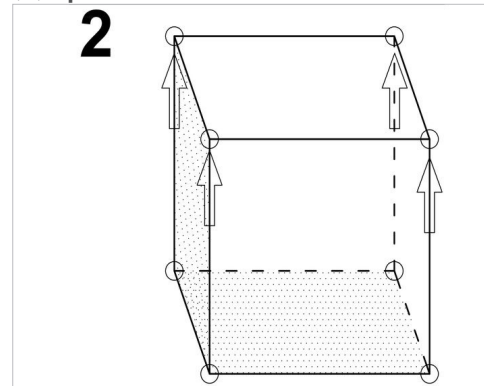

- This is formed by cyclic movement or rotation through each dimension.
- Has the least surface area for volume.
- Most suitable for restraining internal forces.

Design Course

Geometry in Design

Geometrical Construction in 3D Forms

by

Prof. Ravi Mokashi Punekar and

Prof. Avinash Shide

DoD, IIT Guwahati

Source:

<http://www.dsource.in/course/geometry-design/concepts-3-dimensional>

Platonic Solids: A Platonic solid is a convex polyhedron that is regular, in the sense of a regular polygon. Specifically, the faces of a Platonic solid are congruent regular polygons, with the same number of faces meeting at each vertex. Thus, all its edges are congruent, as are its vertices and angles.

There are five (and only Five), polyhedra that fall into the category of platonic solids. While an infinite number of polygons may be drawn on a plane surface, it is not possible to construct more than five regular polyhedral in three-dimensional space. These being the tetrahedron; the octahedron; the icosahedron, the cube and the dodecahedron.

Platonic Solids derive their name from Plato because of his efforts to relate them to the important entities of the universe. The tetrahedron represented molecule of fire, the octahedron the molecule of air, the icosahedron the molecule of water and the cube the molecule of earth, while the dodecahedron represented the all-containing 'ether' or the heavens.

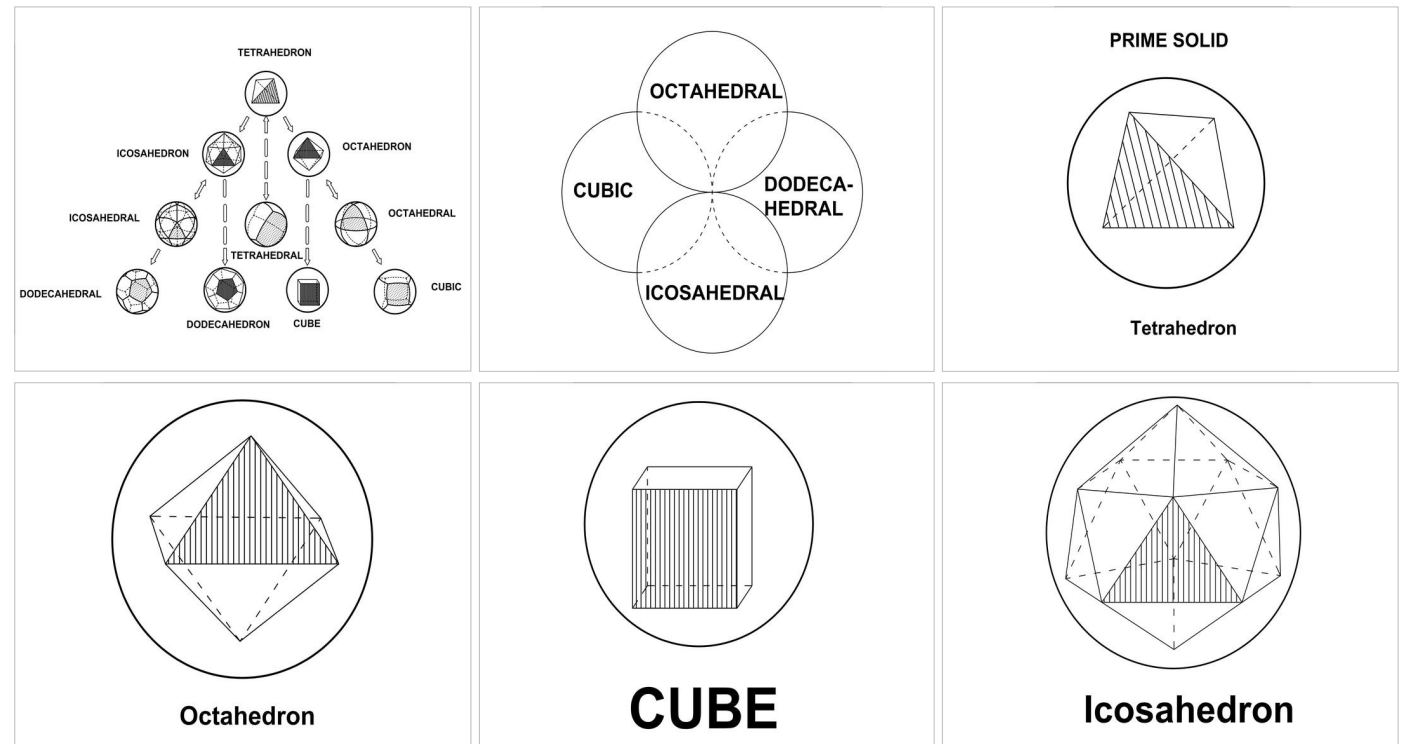

1. Introduction
2. Golden Ratio
3. Polygon - Classification - 2D
4. **Concepts - 3 Dimensional**
5. Family of 3 Dimensional
6. References
7. Contact Details

Design Course

Geometry in Design

Geometrical Construction in 3D Forms

by

Prof. Ravi Mokashi Punekar and

Prof. Avinash Shide

DoD, IIT Guwahati

Source:

<http://www.dsource.in/course/geometry-design/concepts-3-dimensional>

1. Introduction
2. Golden Ratio
3. Polygon - Classification - 2D
4. **Concepts - 3 Dimensional**
5. Family of 3 Dimensional
6. References
7. Contact Details

Entities of the Platonic Solids:

(1) Tetrahedron:

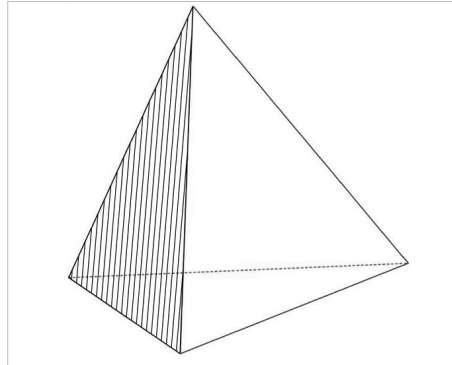

- Edges: 6
- Vertices: 4
- Faces: 4
- 4 Equilateral Triangles
- Symmetry: 2, 3, 3 - Fold

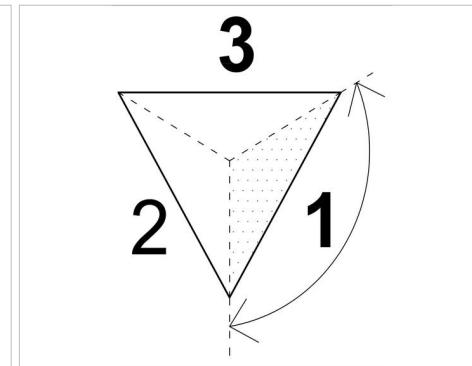
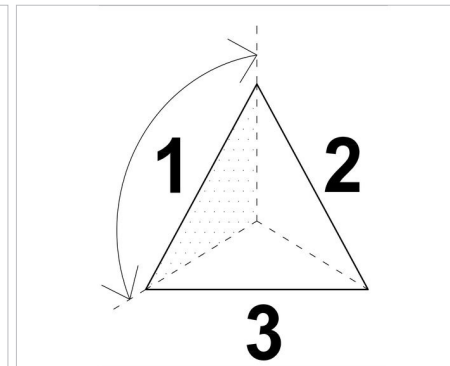
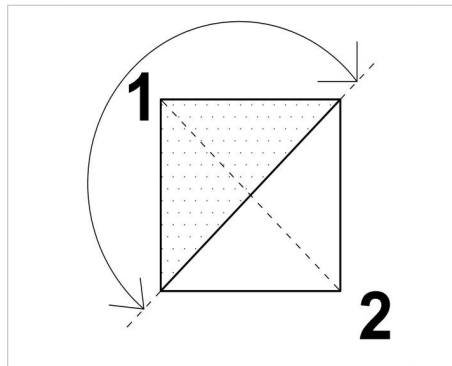

- Dual: Tetrahedron

(2) Cube:

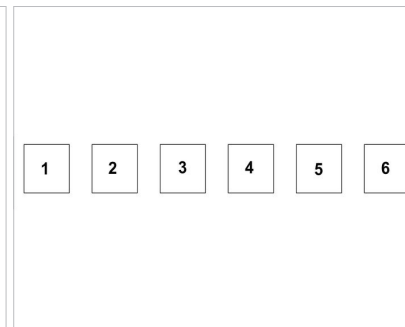
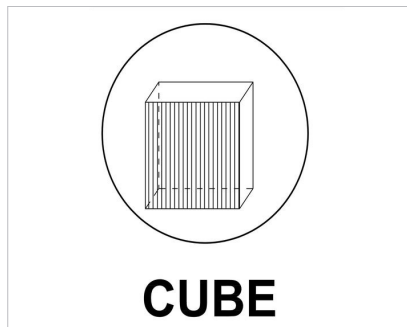

- Edges: 12
- Vertices: 8
- Faces: 6
- 6 squares
- Symmetry: 2,3,4-fold
- Dual: Octahedron

Design Course

Geometry in Design

Geometrical Construction in 3D Forms

by

Prof. Ravi Mokashi Punekar and

Prof. Avinash Shide

DoD, IIT Guwahati

Source:

<http://www.dsource.in/course/geometry-design/concepts-3-dimensional>

1. Introduction
2. Golden Ratio
3. Polygon - Classification - 2D
4. **Concepts - 3 Dimensional**
5. Family of 3 Dimensional
6. References
7. Contact Details

(3) Octahedron:

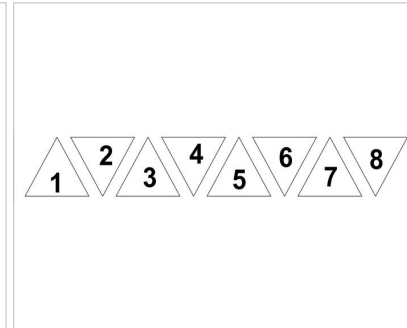
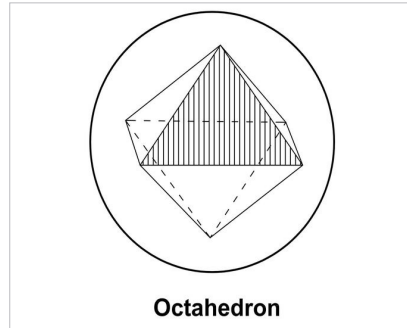

- Edges: 12
- Vertices: 6
- Faces: 8
- 8 equilateral triangles
- Symmetry: 2.3.4-fold
- Dual: Cube

(4) Dodecahedron:

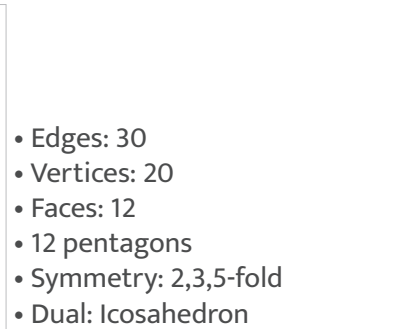

- Edges: 30
- Vertices: 20
- Faces: 12
- 12 pentagons
- Symmetry: 2,3,5-fold
- Dual: Icosahedron

(5) Icosahedron:

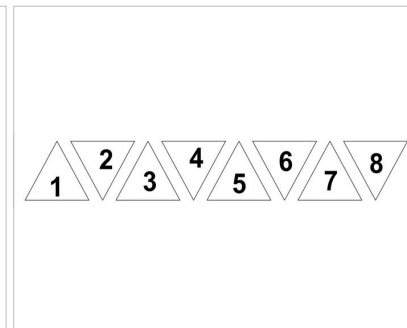
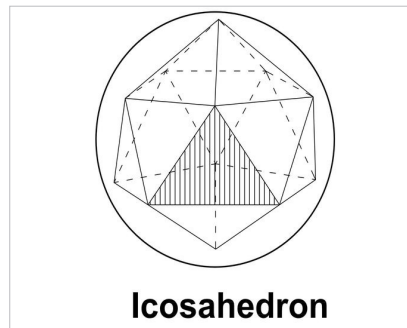

- Edges: 30
- Vertices: 12
- Faces: 20
- 20 equilateral triangles
- Symmetry: 2.3.5-fold
- Dual: Dodecahedron

****Dual:** The line joining the centre-point of the faces of one of the figures results in the other figure.

Design Course

Geometry in Design

Geometrical Construction in 3D Forms

by

Prof. Ravi Mokashi Punekar and

Prof. Avinash Shide

DoD, IIT Guwahati

Source:

<http://www.dsource.in/course/geometry-design/concepts-3-dimensional>

1. Introduction

2. Golden Ratio

3. Polygon - Classification - 2D

4. **Concepts - 3 Dimensional**

5. Family of 3 Dimensional

6. References

7. Contact Details

Evolution of the Basic Spherepoint Configurations:

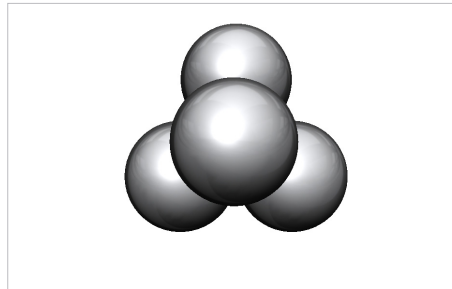

A. Four spheres in tetrahedral configuration are the greatest number that can be in simultaneous contact.

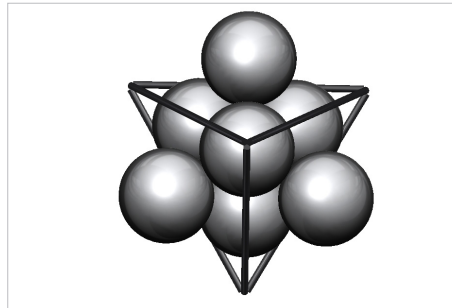

B. The **tetrahedron**, outlined on its edges, with a second set of spheres introduced into the interstices; eight spheres in all.

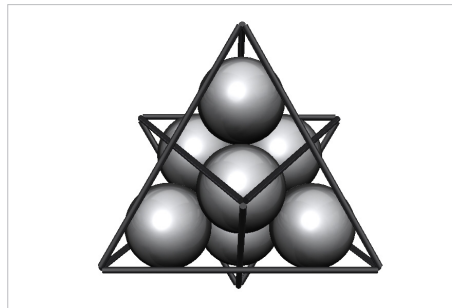

C. The second set of spheres shows that the **tetrahedron** is its own dual – i.e. the lines joining the centre points of the faces repeat the original figure.

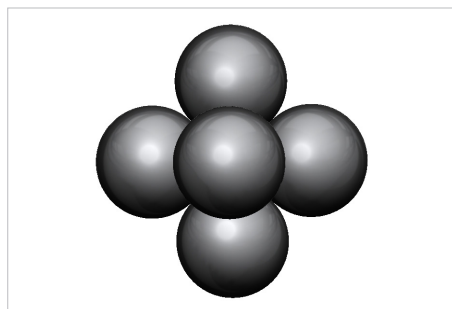

D. The next most regular grouping of spheres is six in octahedral configuration; each sphere touches four others.

Design Course

Geometry in Design

Geometrical Construction in 3D Forms

by

Prof. Ravi Mokashi Punekar and

Prof. Avinash Shide

DoD, IIT Guwahati

Source:

<http://www.dsource.in/course/geometry-design/concepts-3-dimensional>

1. Introduction
2. Golden Ratio
3. Polygon - Classification - 2D
4. **Concepts - 3 Dimensional**
5. Family of 3 Dimensional
6. References
7. Contact Details

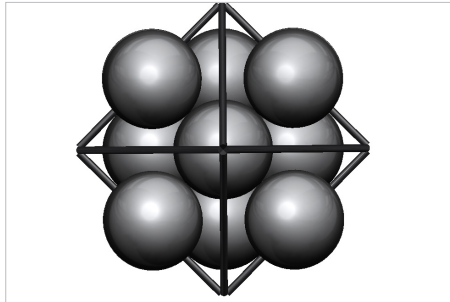

E. The octahedral group outlined with edges, with eight additional spheres in the interstices.

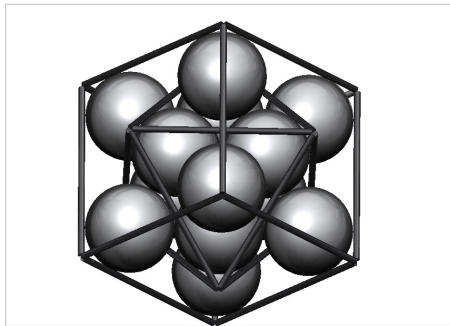

F. When the edges of the second set of spheres are outlined, the **cube** emerges as the dual of the **octahedron**; the lines joining the centre point of the faces of the **octahedron** results in a cube. Conversely, **octahedron** is the dual of the **cube**.

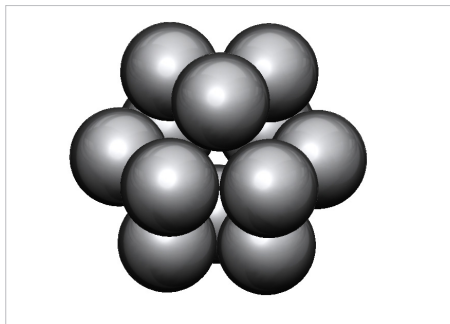

G. The closest packing of equal spheres around a nucleus of equal size gives the **dymaxion** or **cuboctahedron**. The nuclear sphere is surrounded by twelve spheres, each touching four neighbours in addition to the nucleus.

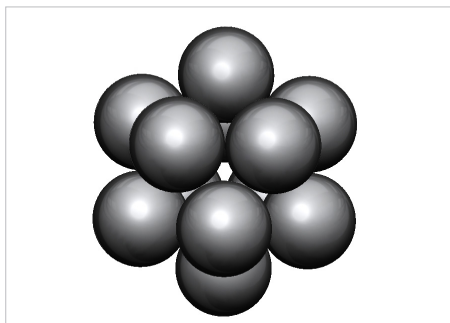

H. The grouping without the nucleus tends to close into the triangulation of the icosahedral grouping; twelve spheres are in closer configuration, each touching five others.

Design Course

Geometry in Design

Geometrical Construction in 3D Forms

by

Prof. Ravi Mokashi Punekar and

Prof. Avinash Shide

DoD, IIT Guwahati

Source:

<http://www.dsource.in/course/geometry-design/concepts-3-dimensional>

1. Introduction

2. Golden Ratio

3. Polygon - Classification - 2D

4. **Concepts - 3 Dimensional**

5. Family of 3 Dimensional

6. References

7. Contact Details

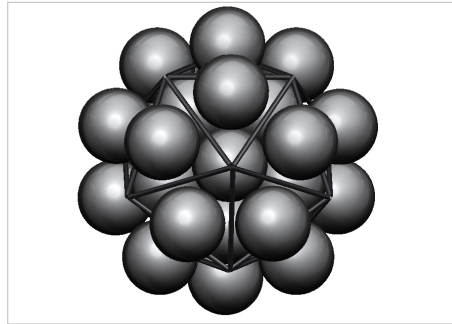

I. The **icosahedron**, with its edges outlined, shown on its 5-fold axis with a sphere introduced into each interstice – 32 spheres in all.

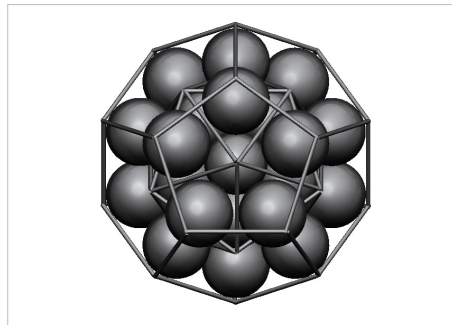

J. The added set of spheres, when outlined, shows that the regular **dodecahedron** is the dual of the **icosahedron**. This demonstrates a hierarchy of the five regular or Platonic solids by the criteria of numerical and structural economy.

From the arrangements of spherepoints , the following principles can be adduced:

- 4 equal spheres are the greatest number that can be in simultaneous contact- the first regular pattern;
- 6 equal spheres are the next regular pattern, with each sphere touching four neighbours;
- 12 equal spheres may surround and touch a nucleus of equal size.

Introducing additional spheres into the interstices of the three regular triangulated patterns generates the dual solid of each. In the first case, the **tetrahedron** is its own dual; in the second case, the **cube** is the dual of **octahedron**; and in the third case, the regular **dodecahedron** is the dual of **icosahedron**. This provides five regular solids from three triangulated close packing of equal spheres by the introduction of a second set of spheres in their interstices.

Yet another way of exploring the hierarchy of solids, adopting the same principles of economy is using the points of contact between the spherepoints rather than their centres.

Design Course

Geometry in Design

Geometrical Construction in 3D Forms

by

Prof. Ravi Mokashi Punekar and

Prof. Avinash Shide

DoD, IIT Guwahati

Source:

<http://www.dsource.in/course/geometry-design/concepts-3-dimensional>

1. Introduction

2. Golden Ratio

3. Polygon - Classification - 2D

4. **Concepts - 3 Dimensional**

5. Family of 3 Dimensional

6. References

7. Contact Details

In drawing 1 we see that if the six points of contact (A,B,C,D,E and F) between the first four spherepoints are joined (E and F being furthest from and nearest to the eye respectively). The result is the **octahedron**, a figure composed of eight equilateral triangles. As the apices of the **octahedron** are exactly half-way along the edges of the basic **tetrahedron** formed by the joining the centres of the spherepoints, we can regard the octahedron as the first 'octave' subdivision of tetrahedron.

In drawing 2 we see that if the **octahedron** is isolated and its apices are simultaneously expanded to become spherepoints in closed-packed relationship one to another, then the links linking the twelve points of contact of these spherepoints (a,b,c,d,e,f,g,h,i,j,k,l) form the figure called the **cuboctahedron** or **dymaxion**, which is made up of a total of 24 edges describing 8 equilateral triangles and 6 squares. The distance between its apices is identical to that from any apex to the centre of the configuration.

Drawing 3 shows that if the cuboctahedron is isolated and the apices expanded as the spherepoints as before, the resulting figure is seen to be stable on only eight faces-the triangular relationships- and unstable on only 8 faces-the square relationships. Triangulation is incomplete. The figure is in equilibrium, but it is unstable because it has no nuclear sphere.

Drawing 4 shows that without this nucleus, the spheres tend to close into a totally stable, triangulated position providing the figure called the icosahedron (a,b,c,d,e,f,g,h,i,j,k,l) which is made up of 30 edges and 20 triangular faces. This is the third and final regular triangular close-packing pattern of equal spheres- regular meaning that all planar, linear, and angular relationships are equal.

It can be seen from the drawings of the transpositions that there are 3 sizes of spherepoints shown, each one half of the preceding it – 3 octave subdivisions. Hence the primary solids have been shown in yet another way to be related in a hierarchy of occurrence.

Exploring the relationships between the points of contact of the six spheres making up the octahedral pattern and the twelve spheres making the icosahedral pattern further, we find:

- The 12 points of contact of six equal spheres resulted in the **cuboctahedron** or **dymaxion**, made up from the eight triangular faces and six square faces. Regularly assembled, the six square faces make up the **cube** and the 8 triangular faces constitute the **octahedron**.
- The 30 points of contact of 12 equal spheres result in an **icosidodecahedron**, made up of 20 equilateral triangles and 12 pentagons which if regularly assembled would have formed **icosahedron** **dodecahedron** respectively.

Design Course

Geometry in Design

Geometrical Construction in 3D Forms

by

Prof. Ravi Mokashi Punekar and

Prof. Avinash Shide

DoD, IIT Guwahati

Source:

<http://www.dsource.in/course/geometry-design/concepts-3-dimensional>

1. Introduction
2. Golden Ratio
3. Polygon - Classification - 2D
4. **Concepts - 3 Dimensional**
5. Family of 3 Dimensional
6. References
7. Contact Details

Hierarchy between the solids could also be established by n-fold symmetry:

The tetrahedron is allocated the first sphere. The next two spheres are allocated to Octahedron and icosahedron as they are prime representatives of 2,3,4 and 2,3,5-fold symmetry respectively. 3 spheres containing the three triangulated inherently structural platonic figures are grouped together. If the two pairs of spheres, containing the prime and secondary representatives of the 2,3,4 and 2,3,5-fold symmetries, i.e. octahedron and cube with icosahedron and dodecahedron, are placed in close packing, the relationship between the four spheres provide the tetrahedron completing the cycle and establishing it again as the master or 'over' solid.

The prime and secondary representatives of the 2, 3, 4-fold symmetrical figures are duals. Similarly, the prime and secondary representatives of the 2, 3, 5-fold symmetrical figures are duals.

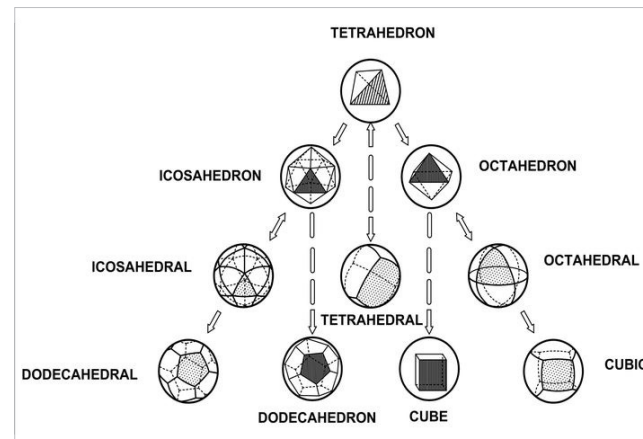

Only seven polygons or shapes singly or combination are needed to define the primary 'orders' of 'surface' or of solid space. These 3,4,5,6,8,10,12-sided polygons are shown together here in the large diagram ; they are all generated from two primary circles , with a common radius A, which is the edge length common to all the polygons. The first polygon is made up by linking A and B to the point of intersection of the primary circles, forming an equilateral triangle. This is the only polygon whose surface is totally enclosed within the common areas of the two primary circles (it is also the only inherently 'stable' structural shape). The subsequent polygons are generated by the progressive unfolding of the sides of the primary triangle.

There are thirteen possible semi-regular solids. Each edge of a semi-regular solid is the same length and is characterized by the centre angle subtended by an edge at the centre of the enclosing sphere commonly denoted theta.

The group of drawings shows the semi-regular solids and their surfaces arranged in two parallel columns as successive truncations of the **icosahedron**, on the left, and, on the right of the **octahedron**.

Design Course

Geometry in Design

Geometrical Construction in 3D Forms

by

Prof. Ravi Mokashi Punekar and

Prof. Avinash Shide

DoD, IIT Guwahati

Source:

<http://www.dsource.in/course/geometry-design/concepts-3-dimensional>

1. Introduction
2. Golden Ratio
3. Polygon - Classification - 2D
4. **Concepts - 3 Dimensional**
5. Family of 3 Dimensional
6. References
7. Contact Details

The surfaces or polygons indicated on the outer edges of the three rows of shapes are the shapes; they represent the amount of surface of the original solid left after truncation in each successive case. The column of surfaces shown vertically shaded is the new faces formed by truncation. The surfaces shown dotted are edges opposed to corner truncations. Only in three instances does this result in an additional shape.

The arrangement is in order of hierarchy from most parent face to least after each successive truncation. An alternative arrangement would ensure if the cube and dodecahedron were taken as parent solids.

A single nuclear sphere totally surrounded by equal and similar spheres has only twelve degrees of freedom for other spheres to touch it simultaneously. This arrangement of thirteen spheres in its most regular pattern is known as the **cuboctahedron** or **dymaxion** . On the two previous pages it has been shown that there are six truncations respectively of the regular octahedron and icosahedrons. These twelve figures together with the one possible truncation of the regular tetrahedron give the thirteen finite Archimedean solids. The definition of an Archimedean or semi-regular solids requires that all its vertices lie in the surface of a circumscribing sphere. Thus the thirteen circumspheres of the Archimedean solids can be grouped in regular cuboctahedron or dymaxion pattern that is the twelve spheres representing the possible truncations of the octahedron or icosahedron around the unique truncation of the tetrahedron. This truncation of tetrahedron has the opposite property of reflecting the twelve degrees of freedom in being the only semi-regular solid figure with twelve.

As with the platonic or regular solids, there are duals to each of the Archimedean or semi-regular. The center-point of each face of each of the Archimedean solids is the vertex of the dual. Each of the solids and its dual come into correspondence when the centre points of their respective edges (crossing at 90 degrees) lie in the surface of a common sphere, known as the intersphere. The full numerical value of the inspheres, interspheres and circumspheres for these figures.

Figure 2 shows the twelve spheres close packed around an equal and similar nuclear sphere.

Figure 3 shows the twelve spheres closed into icosahedral pattern after the removal of the nucleus.

In figure 4, the icosahedral grouping is shown expanded, each of the spheres containing the respective dual of the Archimedean solids represented in figure 1.

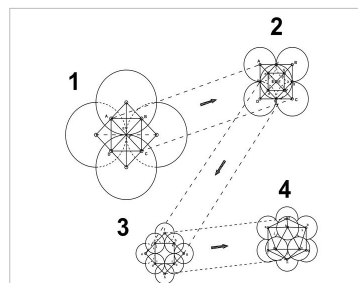

Design Course

Geometry in Design

Geometrical Construction in 3D Forms

by

Prof. Ravi Mokashi Punekar and

Prof. Avinash Shide

DoD, IIT Guwahati

Source:

<http://www.dsource.in/course/geometry-design/concepts-3-dimensional>

1. Introduction
2. Golden Ratio
3. Polygon - Classification - 2D
4. **Concepts - 3 Dimensional**
5. Family of 3 Dimensional
6. References
7. Contact Details

The six duals of the octahedral family are shown in the top half of the diagram, those of the icosahedral family in the bottom half.

In the configuration the two families of symmetry separate out into an above and below reflection of six.

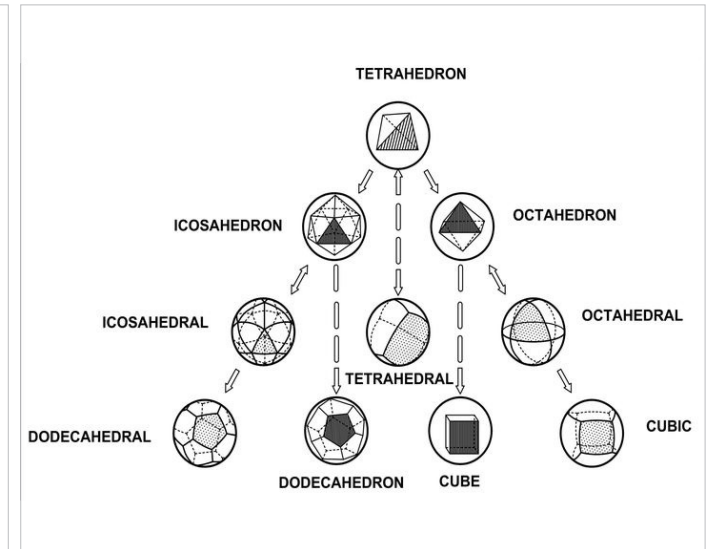
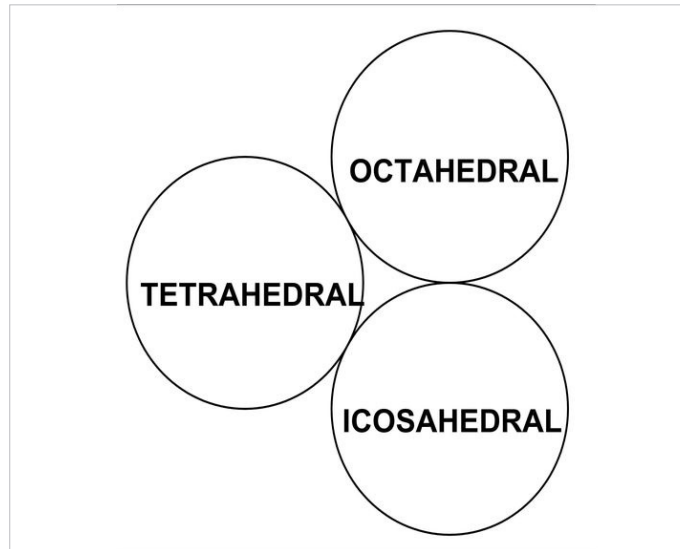

Design Course

Geometry in Design

Geometrical Construction in 3D Forms

by

Prof. Ravi Mokashi Punekar and

Prof. Avinash Shide

DoD, IIT Guwahati

Source:

<http://www.dsource.in/course/geometry-design/family-3-dimensional>

Family of 3 Dimensional

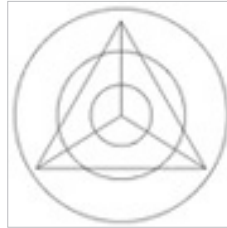

Introduction



Regular Deltahedra



Twin Deltahedra



Irregular Deltahedra

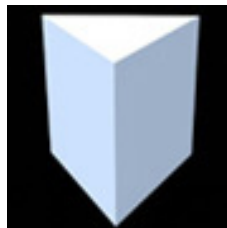

Prism



Truncate



Dodecahedral



Octahedral

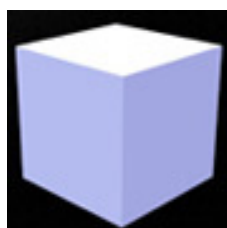

Self Truncate



Dual Prism

1. Introduction
2. Golden Ratio
3. Polygon - Classification - 2D
4. Concepts - 3 Dimensional
5. **Family of 3 Dimensional**
 - 5.1. Introduction
 - 5.2. Regular Deltahedra
 - 5.3. Twin Deltahedra
 - 5.4. Irregular Deltahedra
 - 5.5. Prism
 - 5.6. Truncate
 - 5.7, 5.8, 5.9, 5.10, 5.11, 5.12, 5.13.
6. References
7. Contact Details

Design Course

Geometry in Design

Geometrical Construction in 3D Forms

by

Prof. Ravi Mokashi Punekar and

Prof. Avinash Shide

DoD, IIT Guwahati



Cubic



Truncated Tetrahedron



Paper Model

Source:

<http://www.dsource.in/course/geometry-design/family-3-dimensional>

1. Introduction
2. Golden Ratio
3. Polygon - Classification - 2D
4. Concepts - 3 Dimensional
5. **Family of 3 Dimensional**
 - 5.1. Introduction
 - 5.2. Regular Deltahedra
 - 5.3. Twin Deltahedra
 - 5.4. Irregular Deltahedra
 - 5.5. Prism
 - 5.6. Truncate
 - 5.7, 5.8, 5.9, 5.10, 5.11, 5.12, 5.13.
6. References
7. Contact Details

Design Course

Geometry in Design

Geometrical Construction in 3D Forms

by

Prof. Ravi Mokashi Punekar and

Prof. Avinash Shide

DoD, IIT Guwahati

Source:

<http://www.dsource.in/course/geometry-design/family-3-dimensional/introduction>

Introduction

Construction of Three Dimensional Geometric Forms:

This section outlines the construction of the family of three-dimensional geometric forms. These include the set of five (Regular) Platonic solids and the (Semi-regular) Archimedean solids. The characteristics and features of these Geometric forms can be defined by specifying the following parameters that define the form.

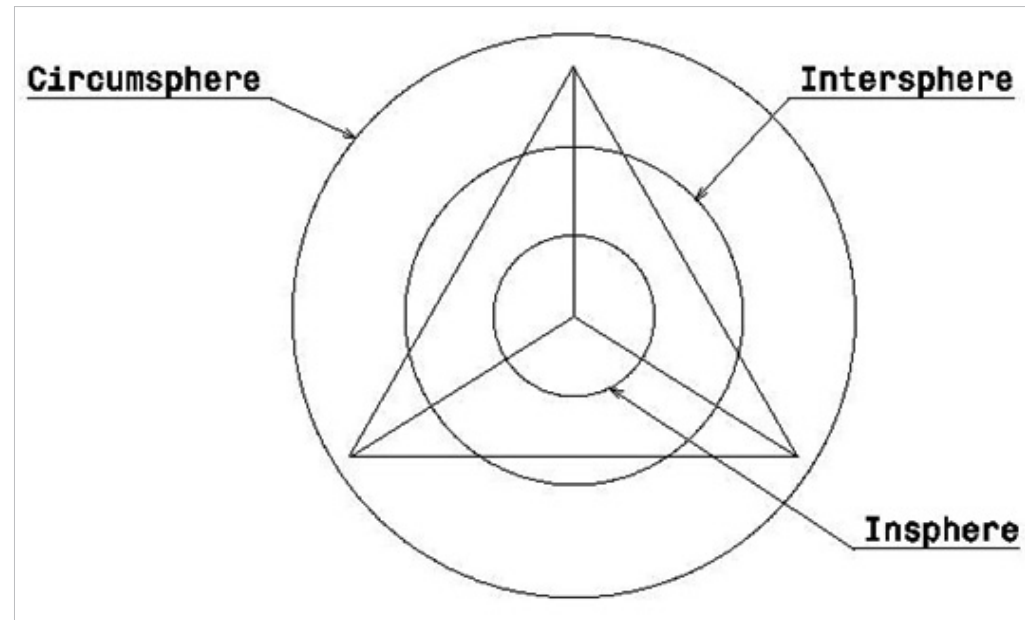

- Apices: AP
- Edges: E
- Faces: F
- Face Angles: F.a
- Dihedral angles: D.a
- Circumsphere radius: Cs.r
- Intersphere radius: Int's.r
- Insphere radius: Ins. r
- Centre Angle: Ca.
- Volume given edge (E): Vol.

• Regular means that all faces, and angles and angles between faces are the same. There are only five, without admitting interpretation, and form the Family of Platonic Forms.

1. Introduction
2. Golden Ratio
3. Polygon - Classification - 2D
4. Concepts - 3 Dimensional
5. Family of 3 Dimensional
 - 5.1. Introduction
 - 5.2. Regular Deltahedra
 - 5.3. Twin Deltahedra
 - 5.4. Irregular Deltahedra
 - 5.5. Prism
 - 5.6. Truncate
 - 5.7, 5.8, 5.9, 5.10, 5.11, 5.12, 5.13.
6. References
7. Contact Details

Design Course

Geometry in Design

Geometrical Construction in 3D Forms

by

Prof. Ravi Mokashi Punekar and

Prof. Avinash Shide

DoD, IIT Guwahati

Source:

<http://www.dsource.in/course/geometry-design/family-3-dimensional/introduction>

1. Introduction
2. Golden Ratio
3. Polygon - Classification - 2D
4. Concepts - 3 Dimensional
5. Family of 3 Dimensional
 - 5.1. Introduction
 - 5.2. Regular Deltahedra
 - 5.3. Twin Deltahedra
 - 5.4. Irregular Deltahedra
 - 5.5. Prism
 - 5.6. Truncate
 - 5.7, 5.8, 5.9, 5.10, 5.11, 5.12, 5.13.
6. References
7. Contact Details

Three are triangulated.

- Semi-regular means that the faces which make up the solid are in themselves regular, but that there is more than one type of face. These form the Family of Archimedean Geometric Forms.

Both regular and Semi-regular figures lie with all the vertices or points in a containing sphere called the Circumsphere.

- Dihedral means between two faces.
- Insphere means the sphere touching the centre of the faces inside the solid.
- Intersphere touches the centre edges of the figure.

A detailed chart outlines the details of the above parameters against each member in the family of Platonic and Archimedean forms.

These have been presented in the following order:

1. 2D drawing of development of the form.
2. Wireframe images.
3. 3D renderings of the final form.

Materials required for Geometrical Construction of paper models:

Using the above images as reference, you are encouraged to construct three dimensional paper models to understand better the concepts in geometrical construction and their inter-relationships.

The following list of material will be necessary to make paper models:

1. Drawing board.
2. T-square (good quality, inexpensive plastic ones are available).
3. Transparent plastic set squares 30/60° and 45°, Size 20 cm and protractor.
4. Transparent plastic scale marked in cm and mm 50 cm. lengths.
5. Drawing instruments – compass large, bow compass, divider (fairly accurate, sturdy and inexpensive).
6. Wooden, drawing pencils in grades 2H, H, HB, B (from hard to soft).
7. Cartridge drawing paper for drawing exercises.
8. Bond paper for notes, exploratory exercises and paper folding exercises.
9. Ivory card and box board for 3D models.
10. Metal scale to be used as cutting edge.
11. Paper cutter with blades.
12. Razor blades for sharpening pencils.
13. Erasers.
14. Tube of adhesive for model building (FEVICOL or equivalent).
15. Drawing pins or Cello-tape.

Design Course

Geometry in Design

Geometrical Construction in 3D Forms

by

Prof. Ravi Mokashi Punekar and

Prof. Avinash Shide

DoD, IIT Guwahati

Source:

<http://www.dsource.in/course/geometry-design/family-3-dimensional/regular-deltahedra>

Regular Deltahedra

2D Construction:

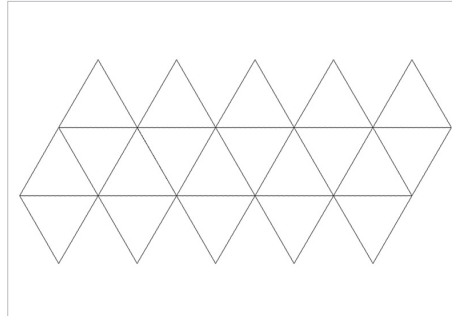

Octahedron

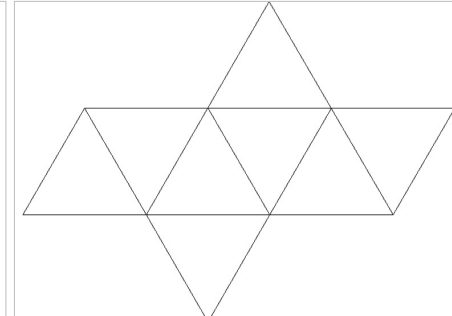

Icosahedron

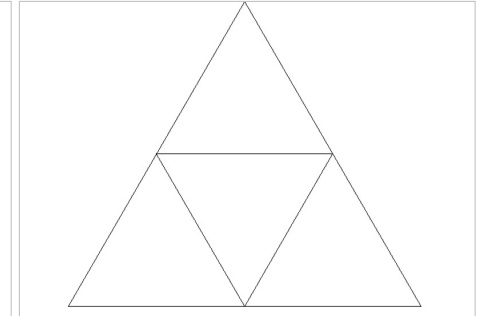

Tetrahedron

2D Rendering:

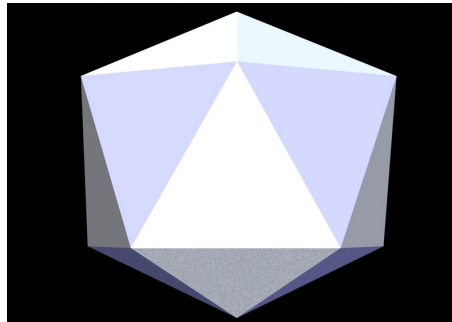

Icosahedron

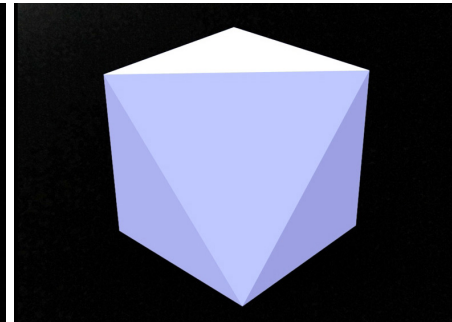

Octahedron

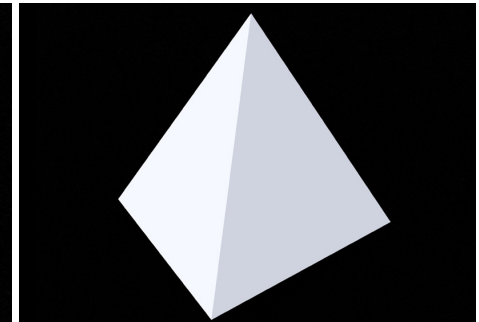

Tetrahedron

3D Wireframe:

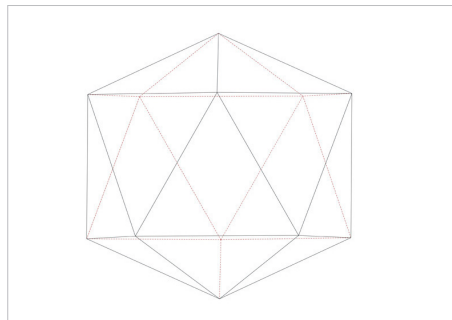

Icosahedron

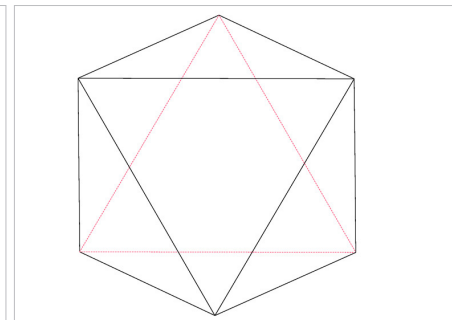

Octahedron

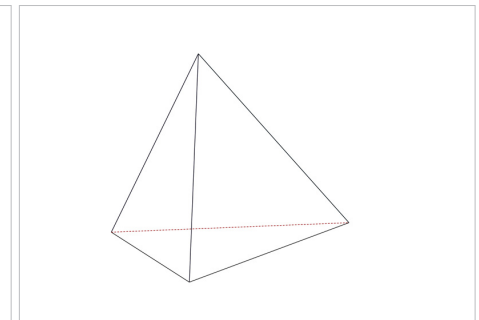

Tetrahedron

1. Introduction
2. Golden Ratio
3. Polygon - Classification - 2D
4. Concepts - 3 Dimensional
5. Family of 3 Dimensional
 - 5.1. Introduction
 - 5.2. **Regular Deltahedra**
 - 5.3. Twin Deltahedra
 - 5.4. Irregular Deltahedra
 - 5.5. Prism
 - 5.6. Truncate
 - 5.7, 5.8, 5.9, 5.10, 5.11, 5.12, 5.13.
6. References
7. Contact Details

Design Course

Geometry in Design

Geometrical Construction in 3D Forms

by

Prof. Ravi Mokashi Punekar and

Prof. Avinash Shide

DoD, IIT Guwahati

Source:

<http://www.dsource.in/course/geometry-design/family-3-dimensional/twin-deltahedra>

Twin Deltahedra

2D Construction:

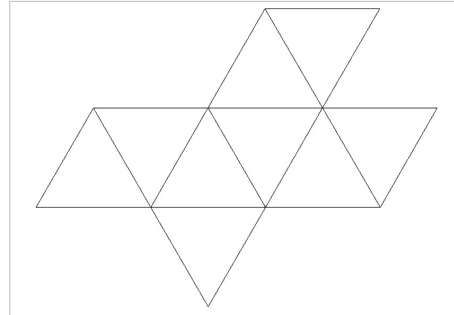

Twin Icosacaps

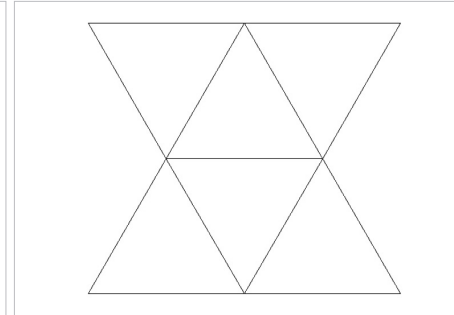

Twin Tetrahedron

3D Rendering:

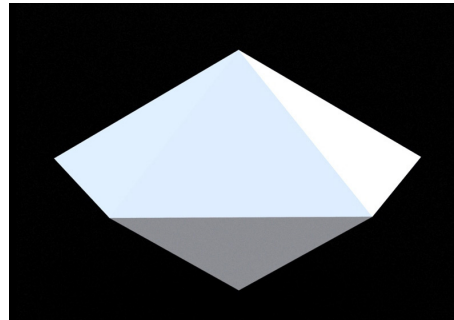

Twin Icosacaps

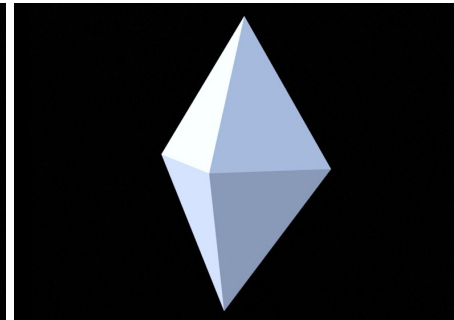

Twin Tetrahedron

3D Wireframe:

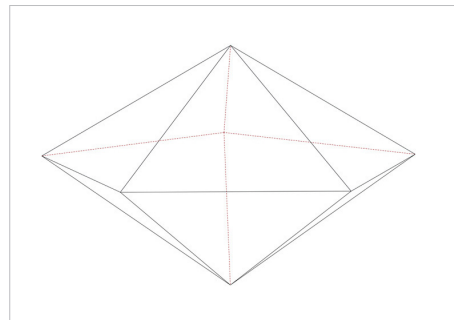

Twin Icosacaps

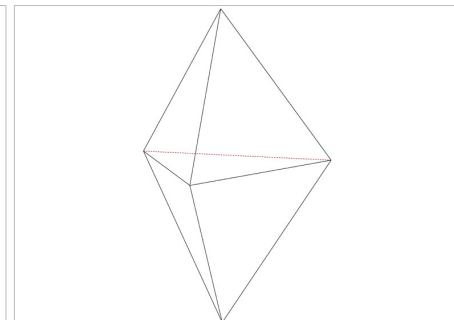

Twin Tetrahedron

1. Introduction
2. Golden Ratio
3. Polygon - Classification - 2D
4. Concepts - 3 Dimensional
5. Family of 3 Dimensional
 - 5.1. Introduction
 - 5.2. Regular Deltahedra
 - 5.3. **Twin Deltahedra**
 - 5.4. Irregular Deltahedra
 - 5.5. Prism
 - 5.6. Truncate
 - 5.7, 5.8, 5.9, 5.10, 5.11, 5.12, 5.13.
6. References
7. Contact Details

Design Course

Geometry in Design

Geometrical Construction in 3D Forms

by

Prof. Ravi Mokashi Punekar and

Prof. Avinash Shide

DoD, IIT Guwahati

Source:

<http://www.dsource.in/course/geometry-design/family-3-dimensional/irregular-deltahedra>

Irregular Deltahedra

2D Construction:

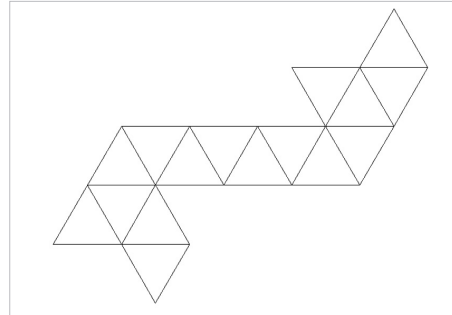

Developed Cubic Antiprism

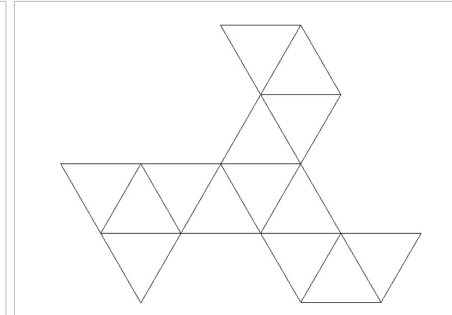

Developed Trigonal Prism

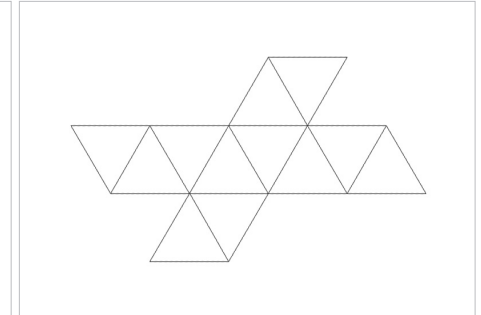

Dodeca Deltahedron

2D Rendering:

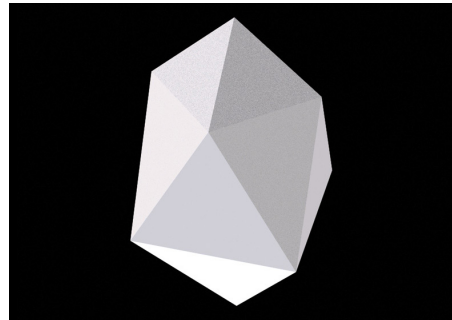

Developed Cubic Antiprism

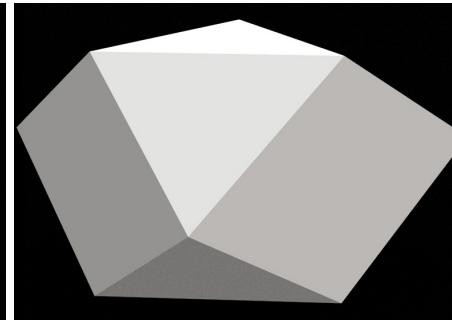

Developed Trigonal Prism

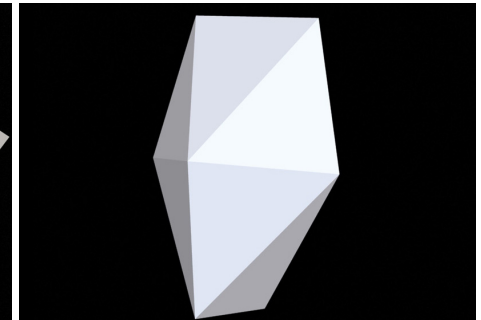

Dodeca Deltahedron

3D Wireframe:

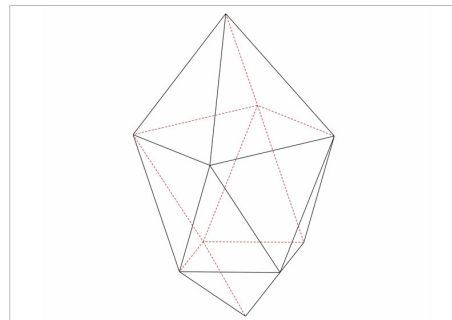

Developed Cubic Antiprism

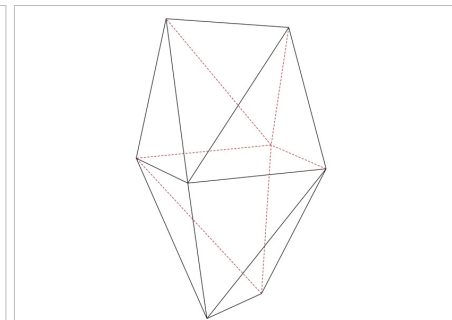

Dodeca Deltahedron

1. Introduction
2. Golden Ratio
3. Polygon - Classification - 2D
4. Concepts - 3 Dimensional
5. Family of 3 Dimensional
 - 5.1. Introduction
 - 5.2. Regular Deltahedra
 - 5.3. Twin Deltahedra
 - 5.4. **Irregular Deltahedra**
 - 5.5. Prism
 - 5.6. Truncate
 - 5.7, 5.8, 5.9, 5.10, 5.11, 5.12, 5.13.
6. References
7. Contact Details

Design Course

Geometry in Design

Geometrical Construction in 3D Forms

by

Prof. Ravi Mokashi Punekar and

Prof. Avinash Shide

DoD, IIT Guwahati

Source:

<http://www.dsource.in/course/geometry-design/family-3-dimensional/prism>

Prism

2D Construction:

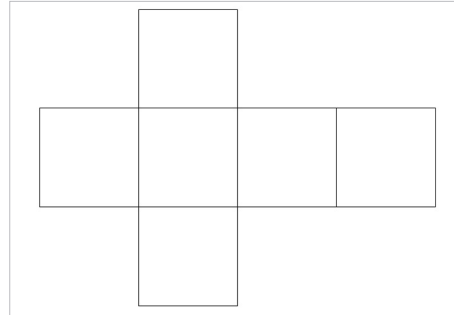

Developed Cubic Antiprism

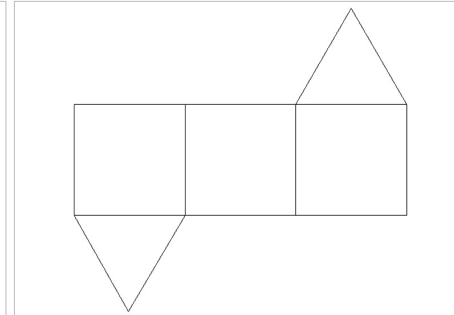

Developed Trigonal Prism

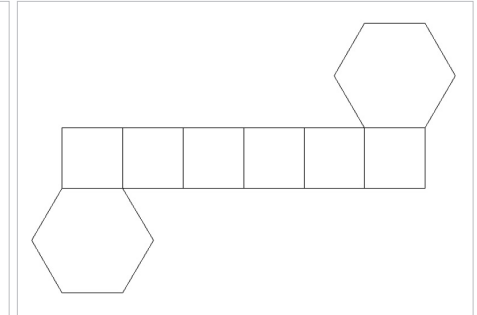

Dodeca Deltahedron

3D Rendering:

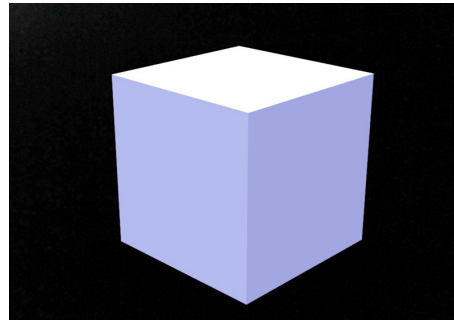

Packing Cubic Prism or Cube

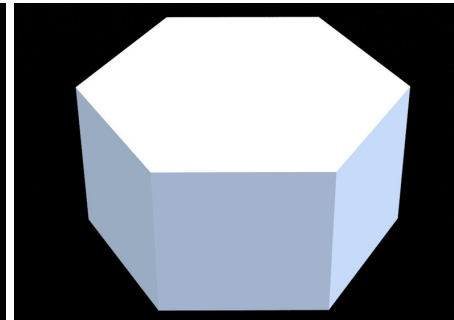

Packing Hexagonal Prism

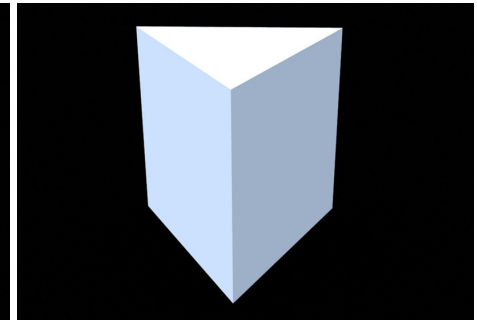

Packing Trigonal Prism

3D Rendering Packing:

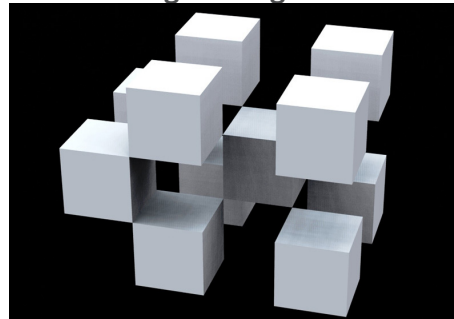

Packing Cubic Prism or Cube

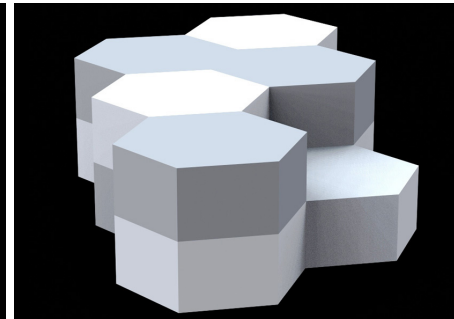

Packing Hexagonal Prism

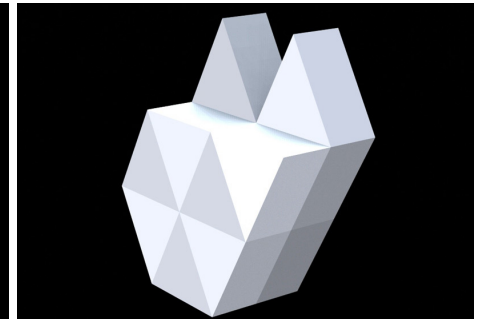

Packing Trigonal Prism

1. Introduction
2. Golden Ratio
3. Polygon - Classification - 2D
4. Concepts - 3 Dimensional
5. Family of 3 Dimensional
 - 5.1. Introduction
 - 5.2. Regular Deltahedra
 - 5.3. Twin Deltahedra
 - 5.4. Irregular Deltahedra
 - 5.5. **Prism**
 - 5.6. Truncate
 - 5.7, 5.8, 5.9, 5.10, 5.11, 5.12, 5.13.
6. References
7. Contact Details

Design Course

Geometry in Design

Geometrical Construction in 3D Forms

by

Prof. Ravi Mokashi Punekar and

Prof. Avinash Shide

DoD, IIT Guwahati

Source:

<http://www.dsource.in/course/geometry-design/family-3-dimensional/prism>

1. Introduction
2. Golden Ratio
3. Polygon - Classification - 2D
4. Concepts - 3 Dimensional
5. Family of 3 Dimensional
 - 5.1. Introduction
 - 5.2. Regular Deltahedra
 - 5.3. Twin Deltahedra
 - 5.4. Irregular Deltahedra
 - 5.5. **Prism**
 - 5.6. Truncate
 - 5.7, 5.8, 5.9, 5.10, 5.11, 5.12, 5.13.
6. References
7. Contact Details

3D Wireframe:

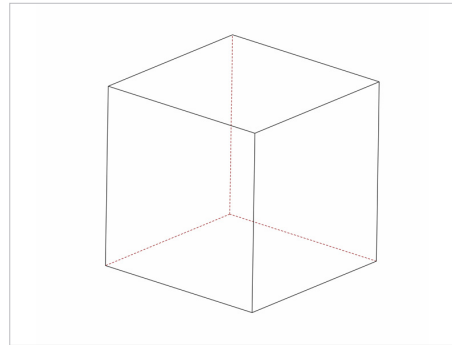

Developed Cubic Antiprism

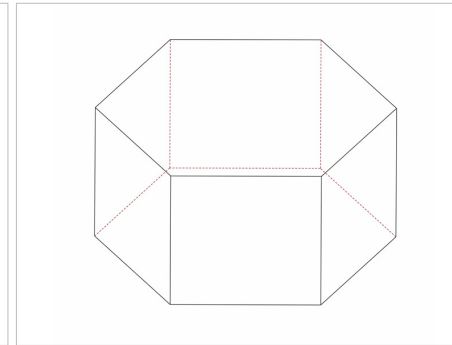

Dodeca Deltahedron

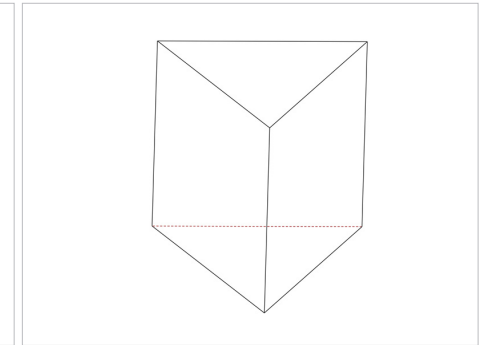

Trigonal Prism

3D Wireframe Packing:

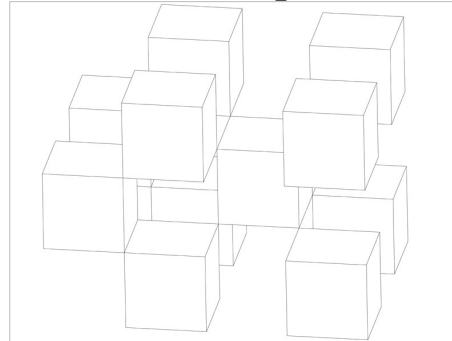

Packing Cubic Prism or Cube

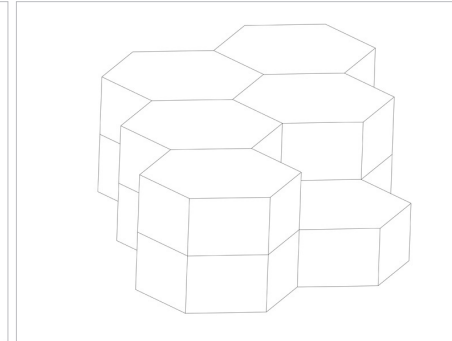

Packing Hexagonal Prism

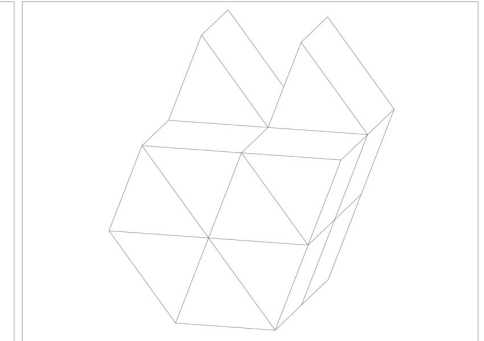

Packing Trigonal Prism

Design Course

Geometry in Design

Geometrical Construction in 3D Forms

by

Prof. Ravi Mokashi Punekar and

Prof. Avinash Shide

DoD, IIT Guwahati

Source:

<http://www.dsource.in/course/geometry-design/family-3-dimensional/truncate>

Truncate

2D Construction:

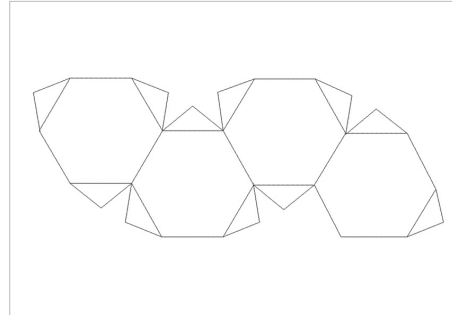

Produced Truncated Tetrahedron

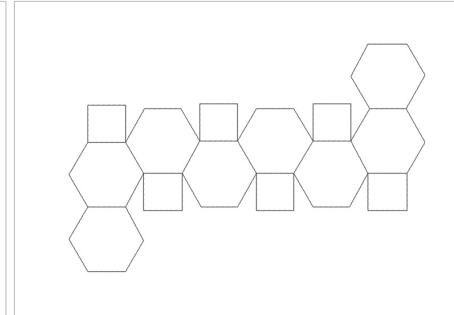

Truncated Octahedron

3D Rendering:

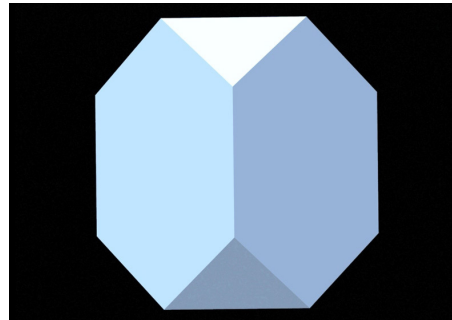

Produced Truncated Tetrahedron

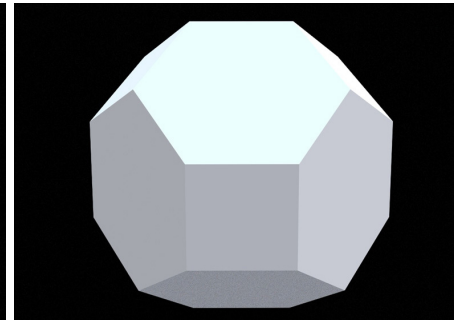

Truncated Octahedron

3D Rendering Packing:

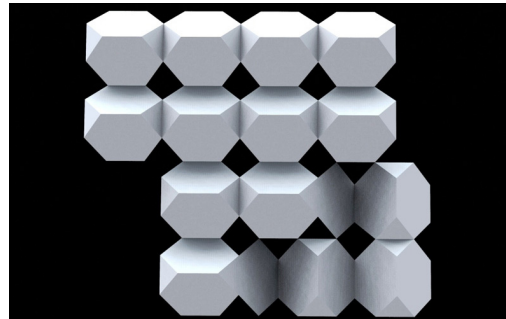

Packing Produced Truncated Tetrahedron

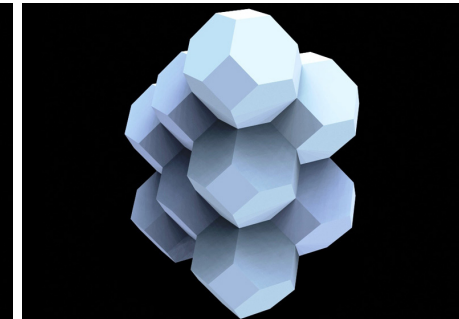

Packing Truncated Octahedron

1. Introduction
2. Golden Ratio
3. Polygon - Classification - 2D
4. Concepts - 3 Dimensional
5. Family of 3 Dimensional
 - 5.1. Introduction
 - 5.2. Regular Deltahedra
 - 5.3. Twin Deltahedra
 - 5.4. Irregular Deltahedra
 - 5.5. Prism
 - 5.6. **Truncate**
 - 5.7, 5.8, 5.9, 5.10, 5.11, 5.12, 5.13.
6. References
7. Contact Details

Design Course

Geometry in Design

Geometrical Construction in 3D Forms

by

Prof. Ravi Mokashi Punekar and

Prof. Avinash Shide

DoD, IIT Guwahati

Source:

<http://www.dsource.in/course/geometry-design/family-3-dimensional/truncate>

1. Introduction
2. Golden Ratio
3. Polygon - Classification - 2D
4. Concepts - 3 Dimensional
5. Family of 3 Dimensional
 - 5.1. Introduction
 - 5.2. Regular Deltahedra
 - 5.3. Twin Deltahedra
 - 5.4. Irregular Deltahedra
 - 5.5. Prism
 - 5.6. **Truncate**
 - 5.7, 5.8, 5.9, 5.10, 5.11, 5.12, 5.13.
6. References
7. Contact Details

3D Wireframe:

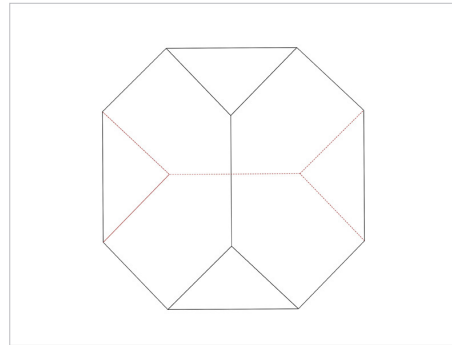

Produced Truncated Tetrahedron

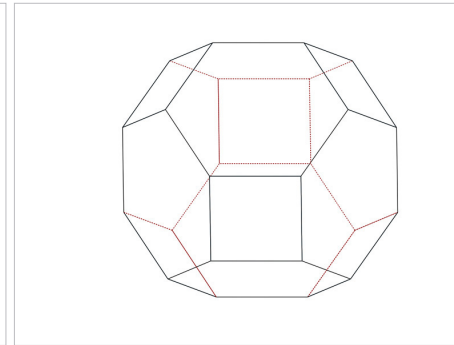

Truncated Octahedron

3D Wireframe Packing:

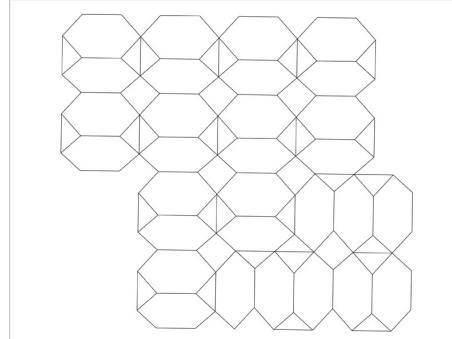

Packing Produced Truncated Tetrahedron

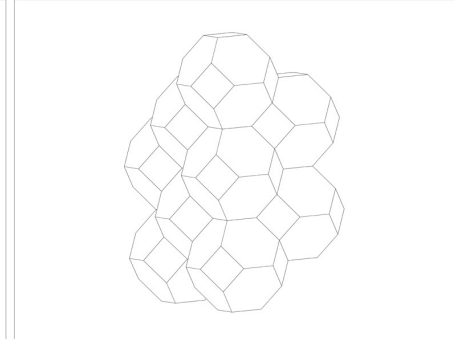

Packing Hexagonal Prism

Design Course

Geometry in Design

Geometrical Construction in 3D Forms

by

Prof. Ravi Mokashi Punekar and

Prof. Avinash Shide

DoD, IIT Guwahati

Source:

<http://www.dsource.in/course/geometry-design/family-3-dimensional/dodecahedral>

Dodecahedral

2D Construction:

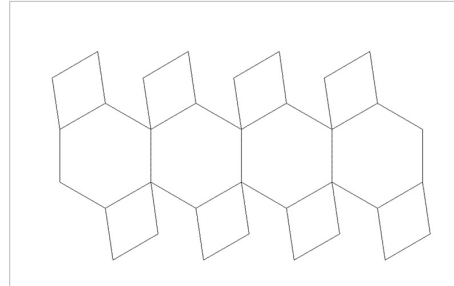

Rhombhex Dodecahedron

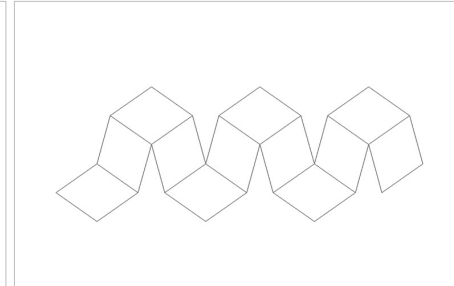

Rhombic Dodecahedron

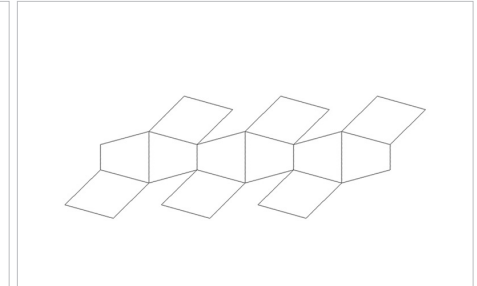

Twist Rhombic Dodecahedron

3D Rendering:

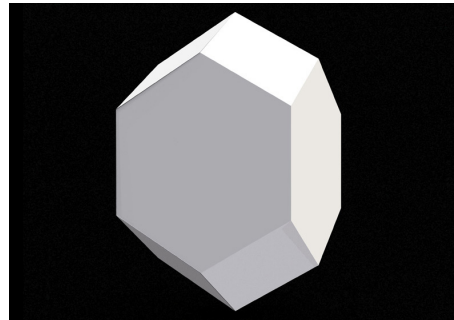

Rhombhex Dodecahedron

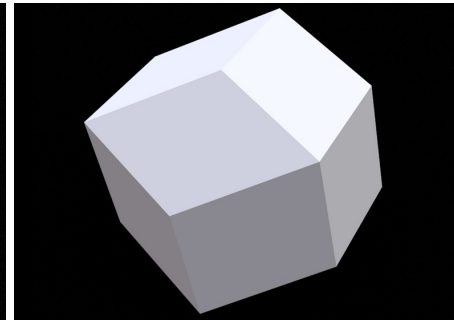

Rhombic Dodecahedron

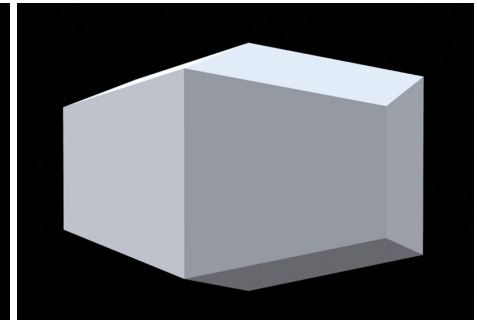

Twist Rhombic Dodecahedron

3D Rendering Packing:

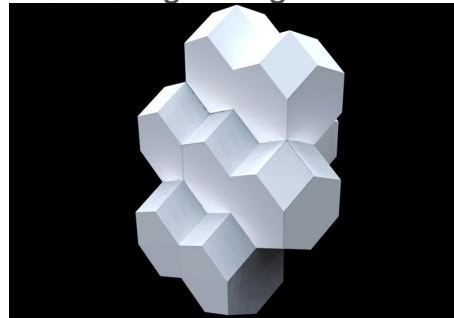

Packing Rhombhex Dodecahedron

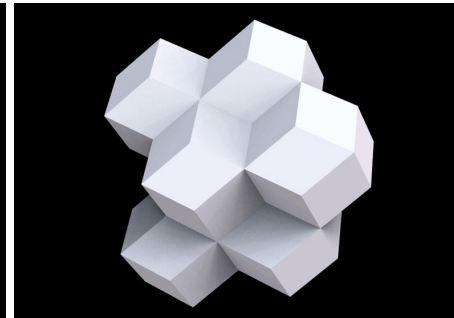

Packing Rhombic Dodecahedron

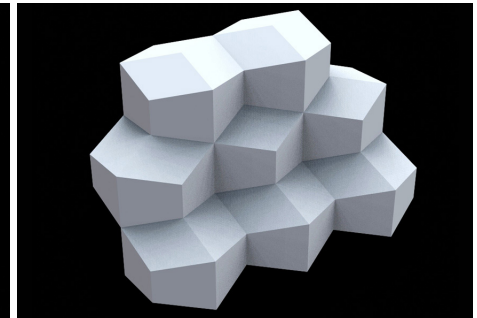

Packing Twist Rhombic Dodecahedron

1. Introduction
2. Golden Ratio
3. Polygon - Classification - 2D
4. Concepts - 3 Dimensional
5. Family of 3 Dimensional
 - 5.1, 5.2, 5.3, 5.4, 5.5, 5.6,
 - 5.7. **Dodecahedral**
 - 5.8. Octahedral
 - 5.9. Self Truncate
 - 5.10. Dual Prism
 - 5.11. Cubic
 - 5.12. Truncated Tetrahedron
 - 5.13. Paper Model
6. References
7. Contact Details

Design Course

Geometry in Design

Geometrical Construction in 3D Forms

by

Prof. Ravi Mokashi Punekar and

Prof. Avinash Shide

DoD, IIT Guwahati

Source:

<http://www.dsource.in/course/geometry-design/family-3-dimensional/dodecahedral>

1. Introduction
2. Golden Ratio
3. Polygon - Classification - 2D
4. Concepts - 3 Dimensional
5. Family of 3 Dimensional
 - 5.1, 5.2, 5.3, 5.4, 5.5, 5.6,
 - 5.7. **Dodecahedral**
 - 5.8. Octahedral
 - 5.9. Self Truncate
 - 5.10. Dual Prism
 - 5.11. Cubic
 - 5.12. Truncated Tetrahedron
 - 5.13. Paper Model
6. References
7. Contact Details

3D Wireframe:

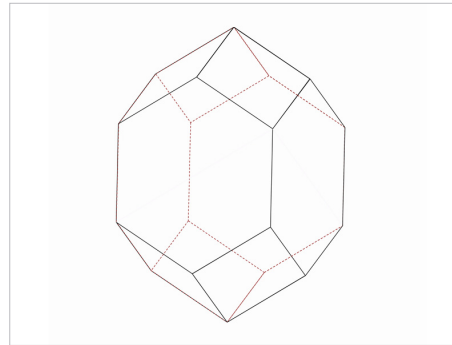

Rhombhex Dodecahedron

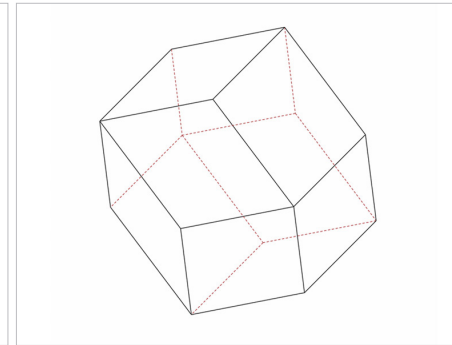

Rhombic Dodecahedron

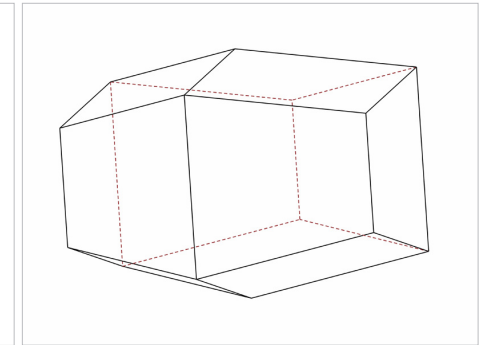

Twist Rhombic Dodecahedron

3D Wireframe Packing:

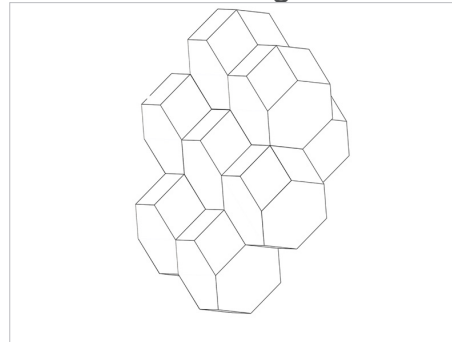

Packing Rhombhex Dodecahedron

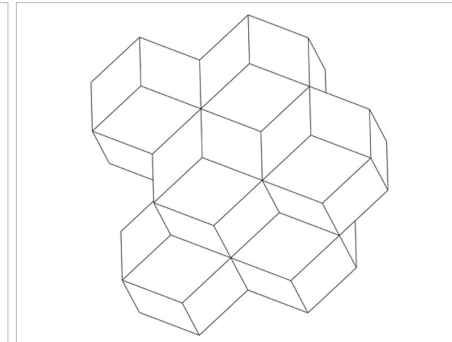

Packing Rhombic Dodecahedron

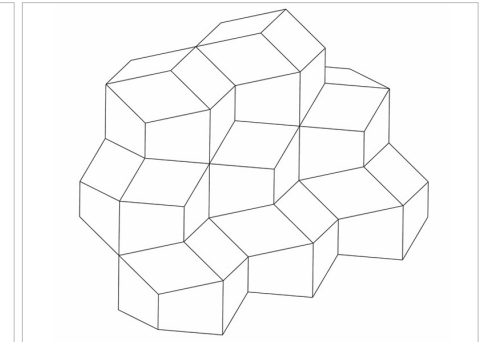

Packing Twist Rhombic Dodecahedron

Design Course

Geometry in Design

Geometrical Construction in 3D Forms

by

Prof. Ravi Mokashi Punekar and

Prof. Avinash Shide

DoD, IIT Guwahati

Source:

<http://www.dsource.in/course/geometry-design/family-3-dimensional/octahedral>

Octahedral

2D Construction:

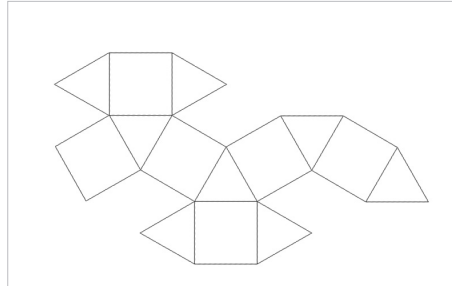

Cubeoctahedron (dymaxion)

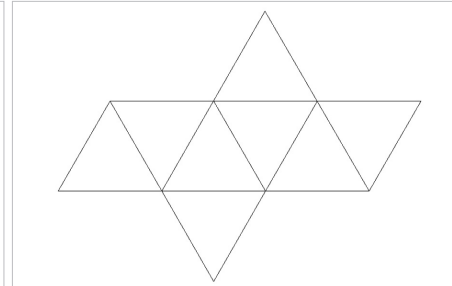

Octahedron

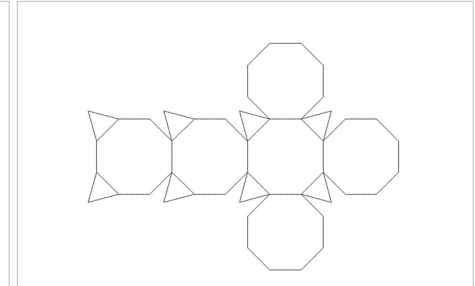

Truncated Cube

3D Rendering:

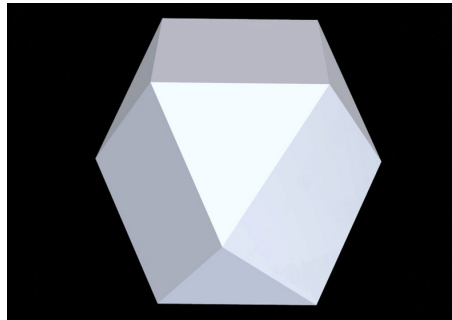

Cubeoctahedron (dymaxion)

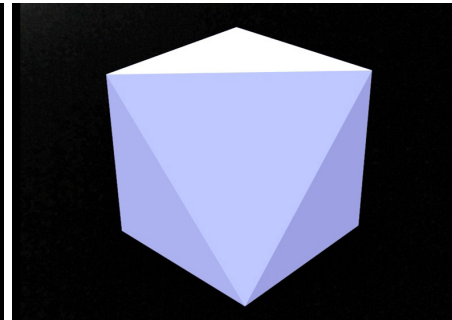

Octahedron

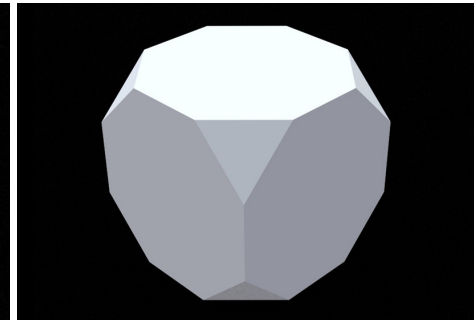

Truncated Cube

3D Rendering Packing:

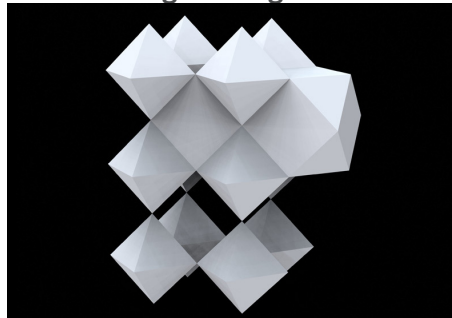

Packing Cubeoctahedron (dymaxion)

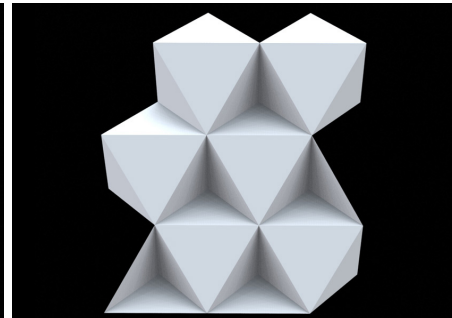

Packing Octahedron

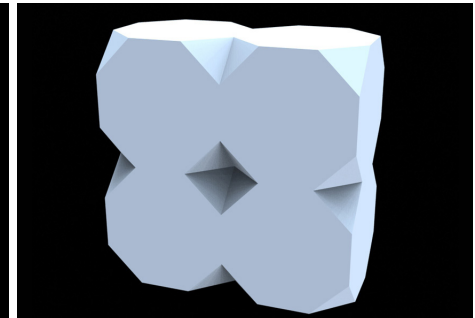

Packing Truncated Cube

1. Introduction
2. Golden Ratio
3. Polygon - Classification - 2D
4. Concepts - 3 Dimensional
5. Family of 3 Dimensional
 - 5.1, 5.2, 5.3, 5.4, 5.5, 5.6,
 - 5.7. Dodecahedral
 - 5.8. **Octahedral**
 - 5.9. Self Truncate
 - 5.10. Dual Prism
 - 5.11. Cubic
 - 5.12. Truncated Tetrahedron
 - 5.13. Paper Model
6. References
7. Contact Details

Design Course

Geometry in Design

Geometrical Construction in 3D Forms

by

Prof. Ravi Mokashi Punekar and

Prof. Avinash Shide

DoD, IIT Guwahati

Source:

<http://www.dsource.in/course/geometry-design/family-3-dimensional/octahedral>

1. Introduction
2. Golden Ratio
3. Polygon - Classification - 2D
4. Concepts - 3 Dimensional
5. Family of 3 Dimensional
 - 5.1, 5.2, 5.3, 5.4, 5.5, 5.6,
 - 5.7. Dodecahedral
 - 5.8. **Octahedral**
 - 5.9. Self Truncate
 - 5.10. Dual Prism
 - 5.11. Cubic
 - 5.12. Truncated Tetrahedron
 - 5.13. Paper Model
6. References
7. Contact Details

3D Wireframe:

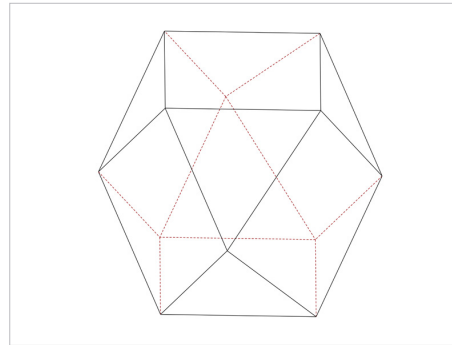

Cubeoctahedron (dymaxion)

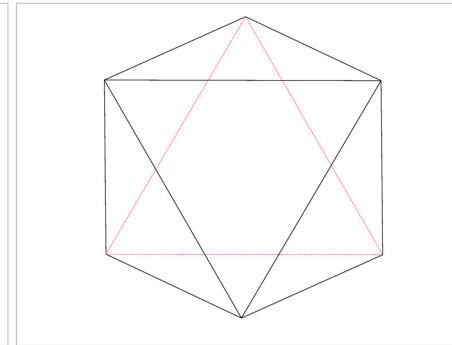

Octahedron

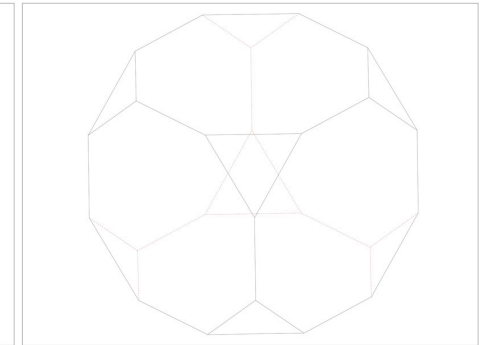

Truncated Cube

3D Wireframe Packing:

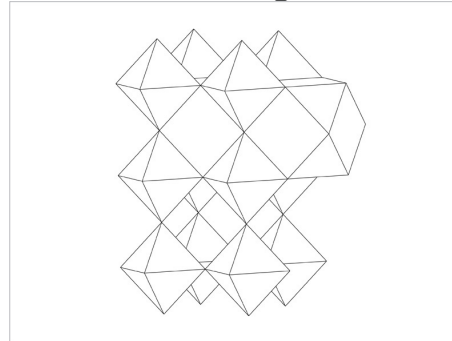

Packing Cubeoctahedron (dymaxion)

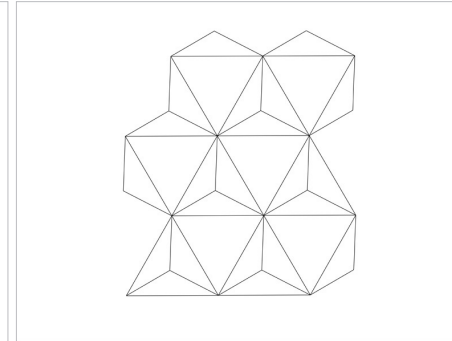

Packing Octahedron

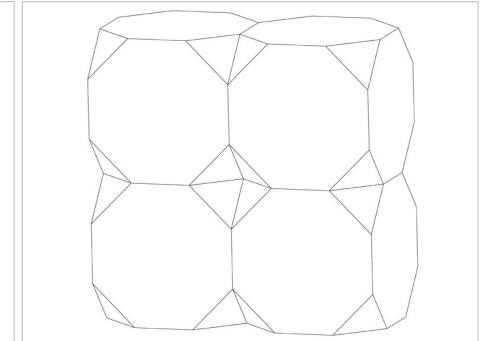

Packing Truncated Cube

Design Course

Geometry in Design

Geometrical Construction in 3D Forms

by

Prof. Ravi Mokashi Punekar and

Prof. Avinash Shide

DoD, IIT Guwahati

Source:

<http://www.dsource.in/course/geometry-design/family-3-dimensional/self-truncate>

Self Truncate

2D Construction:

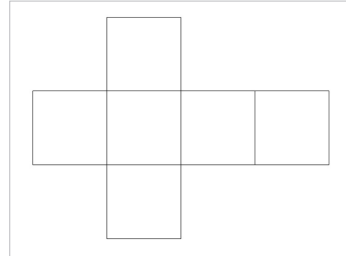

Cubic Prism or Cube

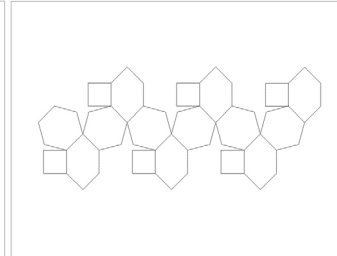

Edge Truncatd Cube

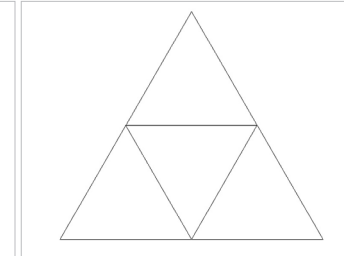

Tetrahedron

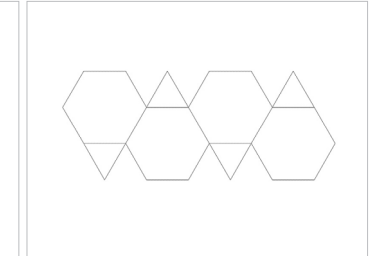

Truncated Tetrahedron

3D Rendering:

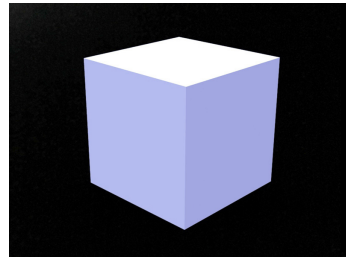

Cubic Prism or Cube

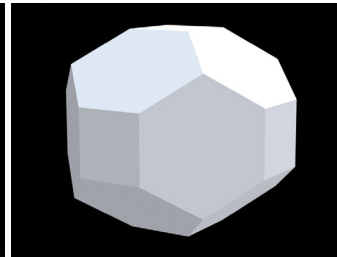

Edge Truncatd Cube

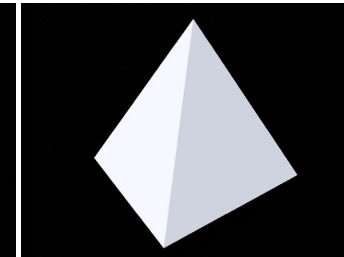

Tetrahedron

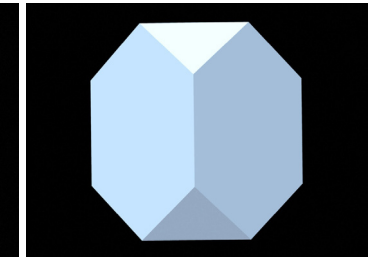

Truncated Tetrahedron

3D Rendering Packing:

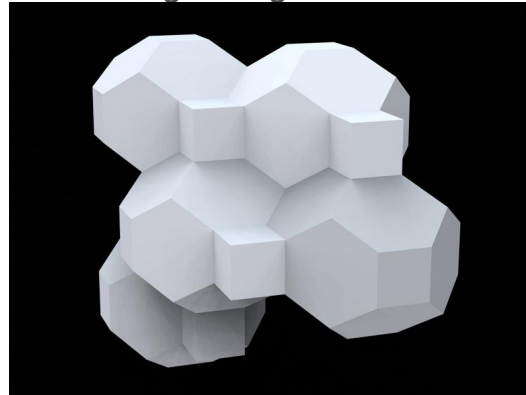

Packing Edge Truncatd Cube

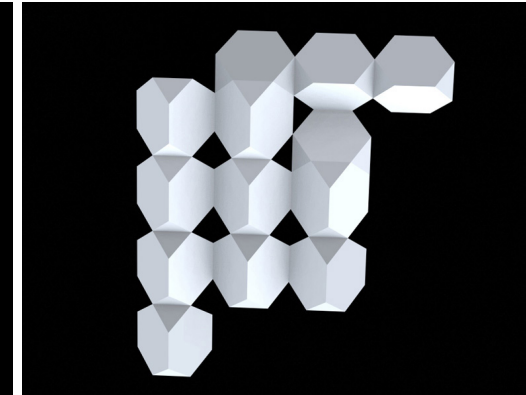

Packing Truncated Tetrahedron

1. Introduction
2. Golden Ratio
3. Polygon - Classification - 2D
4. Concepts - 3 Dimensional
5. Family of 3 Dimensional
 - 5.1, 5.2, 5.3, 5.4, 5.5, 5.6,
 - 5.7. Dodecahedral
 - 5.8. Octahedral
 - 5.9. **Self Truncate**
 - 5.10. Dual Prism
 - 5.11. Cubic
 - 5.12. Truncated Tetrahedron
 - 5.13. Paper Model
6. References
7. Contact Details

Design Course

Geometry in Design

Geometrical Construction in 3D Forms

by

Prof. Ravi Mokashi Punekar and

Prof. Avinash Shide

DoD, IIT Guwahati

Source:

<http://www.dsource.in/course/geometry-design/family-3-dimensional/self-truncate>

1. Introduction
2. Golden Ratio
3. Polygon - Classification - 2D
4. Concepts - 3 Dimensional
5. Family of 3 Dimensional
 - 5.1, 5.2, 5.3, 5.4, 5.5, 5.6,
 - 5.7. Dodecahedral
 - 5.8. Octahedral
 - 5.9. **Self Truncate**
 - 5.10. Dual Prism
 - 5.11. Cubic
 - 5.12. Truncated Tetrahedron
 - 5.13. Paper Model
6. References
7. Contact Details

3D Wireframe:

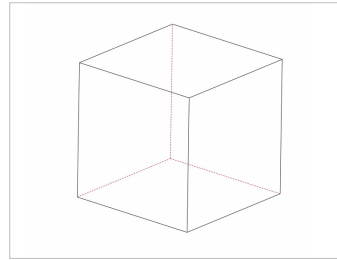

Cubic Prism or Cube

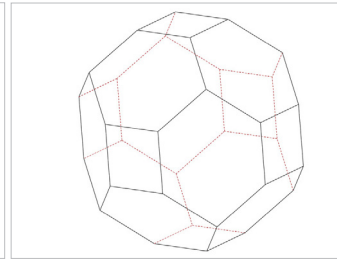

Edge Truncated Cube

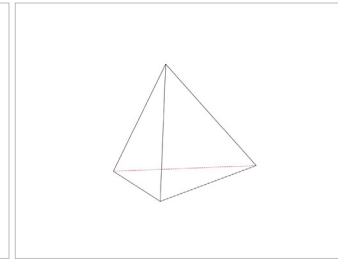

Tetrahedron

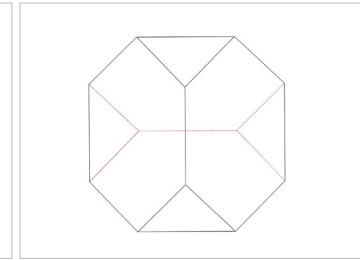

Truncated Tetrahedron

3D Rendering Packing:

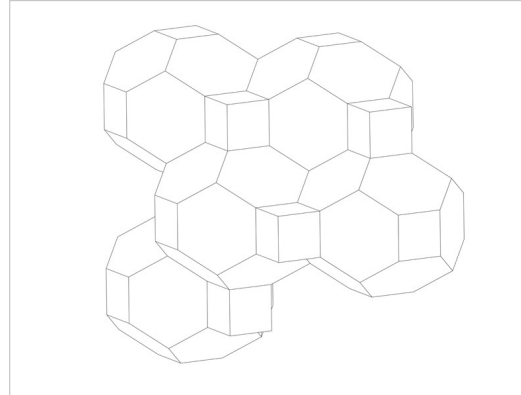

Packing Edge Truncated Cube

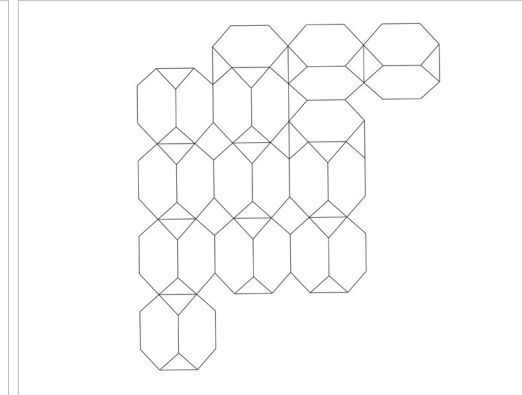

Packing Truncated Tetrahedron

Design Course

Geometry in Design

Geometrical Construction in 3D Forms

by

Prof. Ravi Mokashi Punekar and

Prof. Avinash Shide

DoD, IIT Guwahati

Source:

<http://www.dsource.in/course/geometry-design/family-3-dimensional/dual-prism>

Dual Prism

2D Construction:

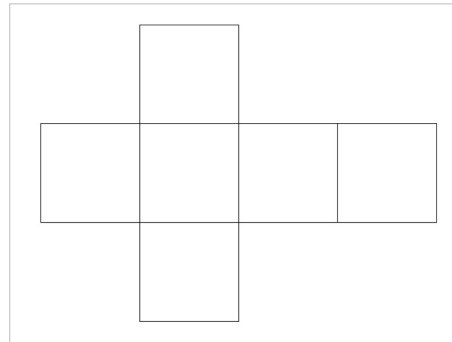
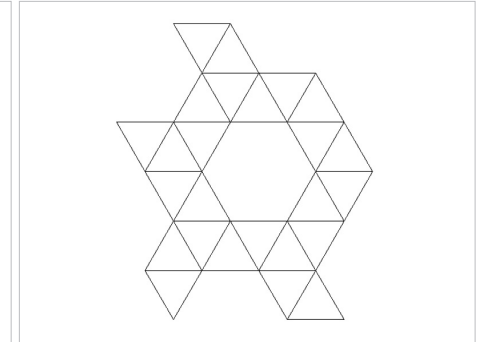
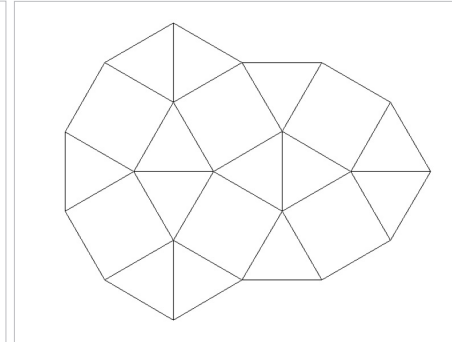
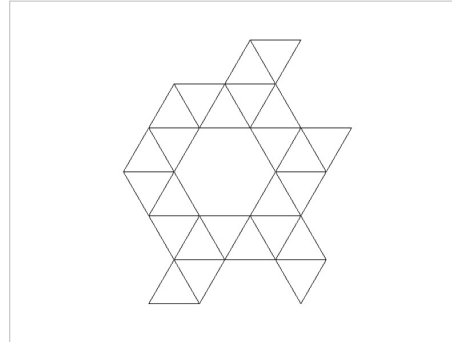

Cubic Prism or Cube

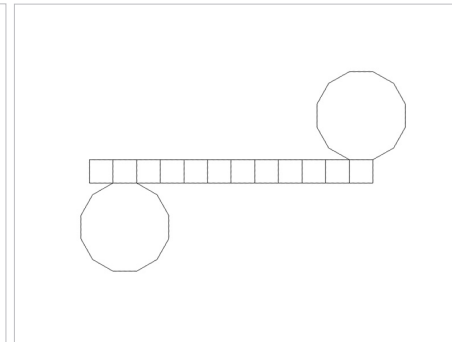

Dodeca Prism

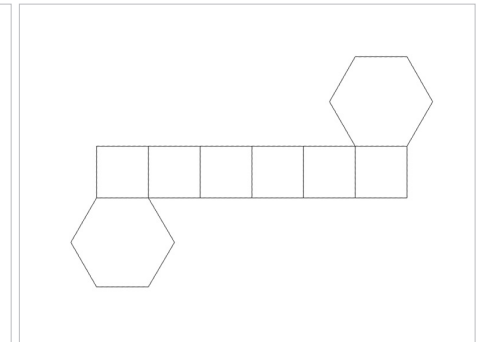

Hexagonal Prism

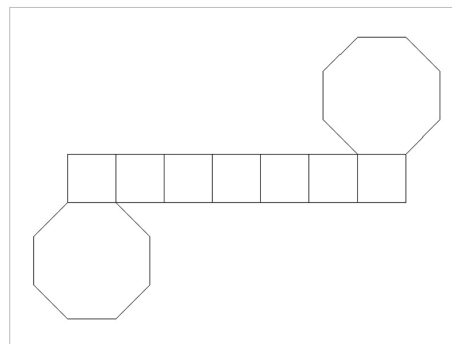

Octagonal Prism

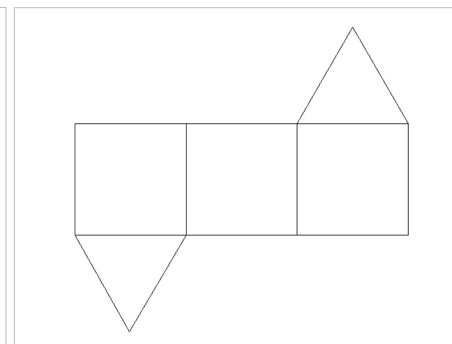

Trigonal Prism

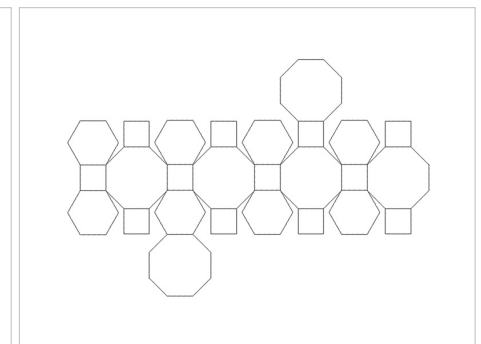

Truncated Dymaxion

1. Introduction
2. Golden Ratio
3. Polygon - Classification - 2D
4. Concepts - 3 Dimensional
5. Family of 3 Dimensional
 - 5.1, 5.2, 5.3, 5.4, 5.5, 5.6,
 - 5.7. Dodecahedral
 - 5.8. Octahedral
 - 5.9. Self Truncate
 - 5.10. **Dual Prism**
 - 5.11. Cubic
 - 5.12. Truncated Tetrahedron
 - 5.13. Paper Model
6. References
7. Contact Details

Design Course

Geometry in Design

Geometrical Construction in 3D Forms

by

Prof. Ravi Mokashi Punekar and

Prof. Avinash Shide

DoD, IIT Guwahati

Source:

<http://www.dsource.in/course/geometry-design/family-3-dimensional/dual-prism>

3D Rendering:

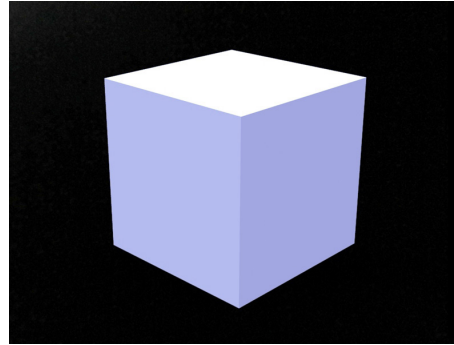

Cubic Prism or Cube

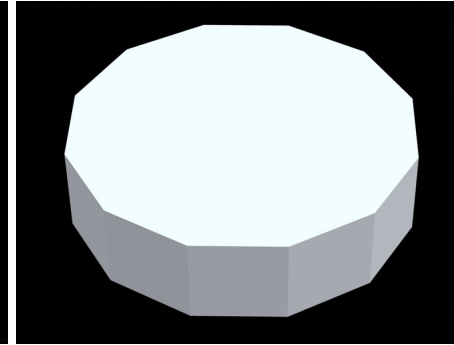

Dodeca Prism

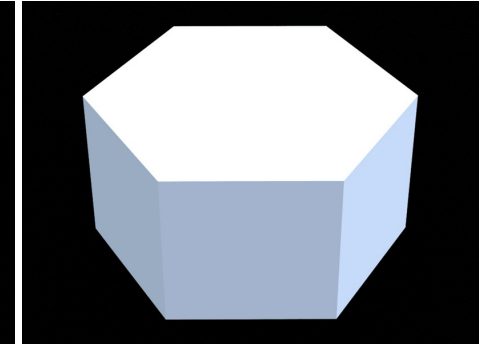

Hexagonal Prism

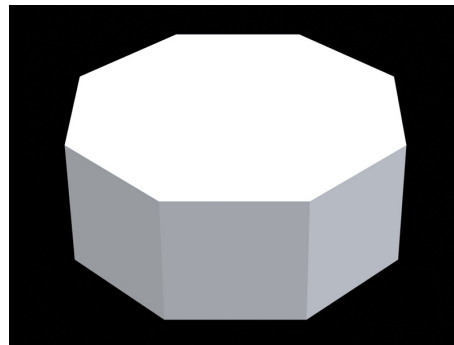

Octagonal Prism

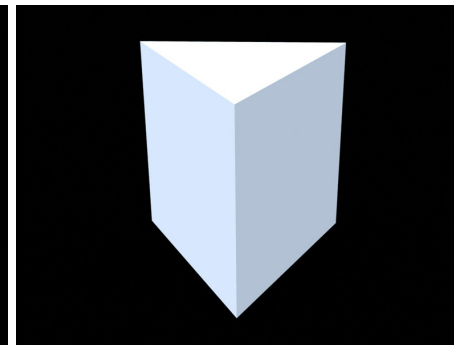

Trigonal Prism

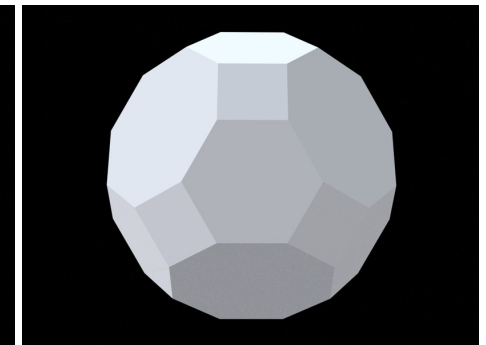

Truncated Dymaxion

1. Introduction
2. Golden Ratio
3. Polygon - Classification - 2D
4. Concepts - 3 Dimensional
5. Family of 3 Dimensional
 - 5.1, 5.2, 5.3, 5.4, 5.5, 5.6,
 - 5.7. Dodecahedral
 - 5.8. Octahedral
 - 5.9. Self Truncate
 - 5.10. **Dual Prism**
 - 5.11. Cubic
 - 5.12. Truncated Tetrahedron
 - 5.13. Paper Model
6. References
7. Contact Details

Design Course

Geometry in Design

Geometrical Construction in 3D Forms

by

Prof. Ravi Mokashi Punekar and

Prof. Avinash Shide

DoD, IIT Guwahati

Source:

<http://www.dsource.in/course/geometry-design/family-3-dimensional/dual-prism>

3D Rendering Packing:

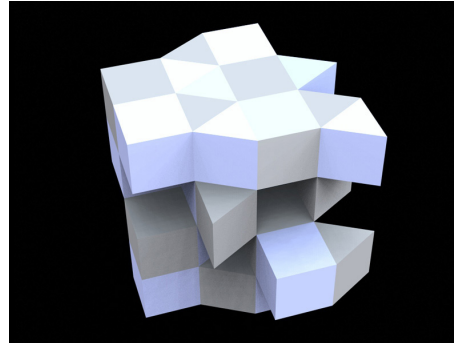

Packing Cubic Prism-Cube

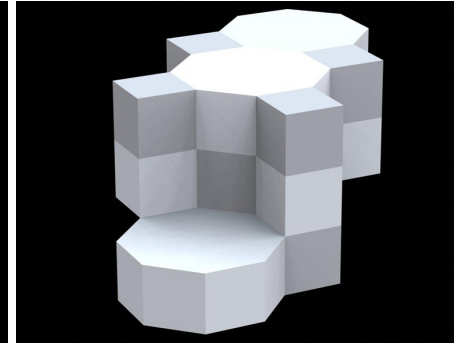

Packing Cubic Prism -
Octagonal Prism

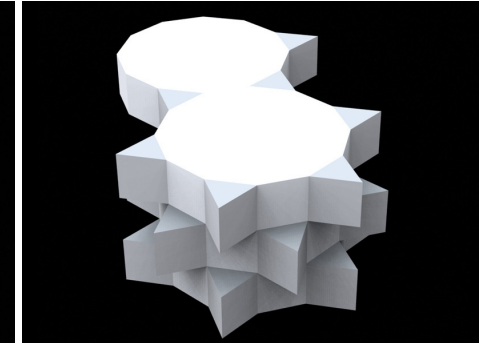

Hexagonal Prism

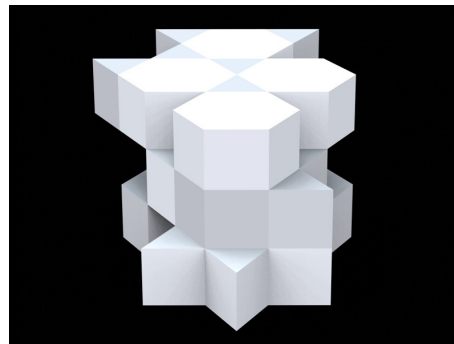

Packing Trigonal Prism -
Hexagonal Prism

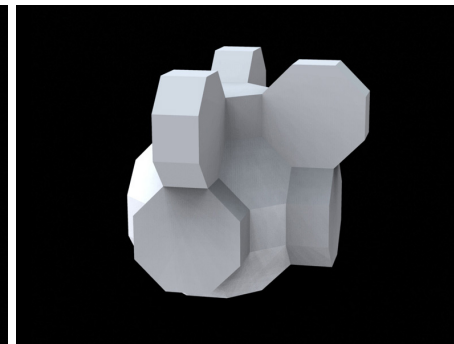

Packing Truncated Dymaxion -
Octagonal Prism

1. Introduction
2. Golden Ratio
3. Polygon - Classification - 2D
4. Concepts - 3 Dimensional
5. Family of 3 Dimensional
 - 5.1, 5.2, 5.3, 5.4, 5.5, 5.6,
 - 5.7. Dodecahedral
 - 5.8. Octahedral
 - 5.9. Self Truncate
 - 5.10. **Dual Prism**
 - 5.11. Cubic
 - 5.12. Truncated Tetrahedron
 - 5.13. Paper Model
6. References
7. Contact Details

Design Course

Geometry in Design

Geometrical Construction in 3D Forms

by

Prof. Ravi Mokashi Punekar and

Prof. Avinash Shide

DoD, IIT Guwahati

Source:

<http://www.dsource.in/course/geometry-design/family-3-dimensional/dual-prism>

3D Wireframe:

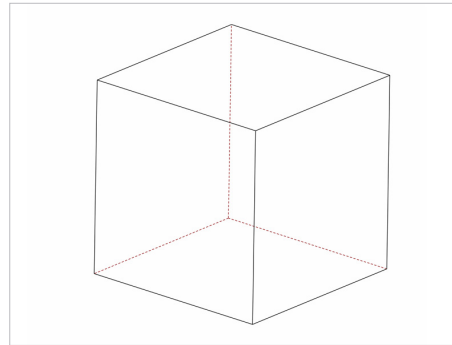

Cubic Prism or Cube

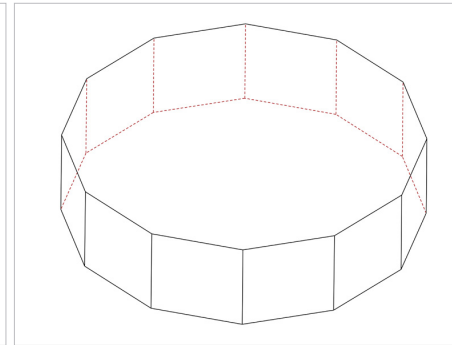

Dodeca Prism

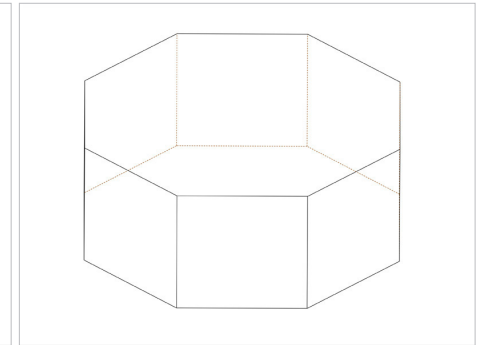

Octagonal Prism

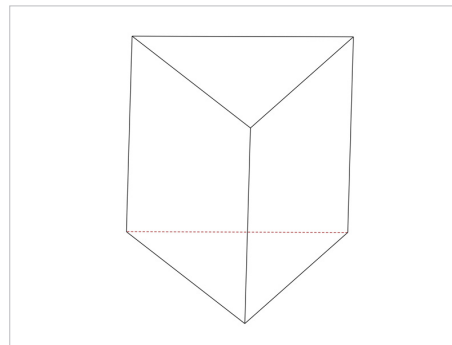

Trigonal Prism

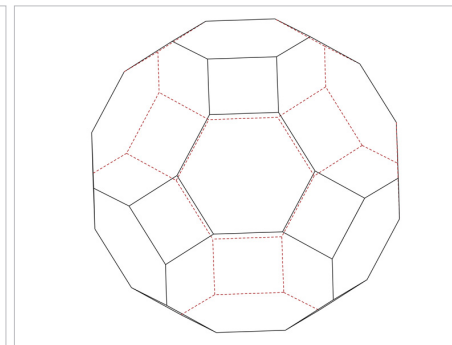

Truncated Dymaxion

1. Introduction
2. Golden Ratio
3. Polygon - Classification - 2D
4. Concepts - 3 Dimensional
5. Family of 3 Dimensional
 - 5.1, 5.2, 5.3, 5.4, 5.5, 5.6,
 - 5.7. Dodecahedral
 - 5.8. Octahedral
 - 5.9. Self Truncate
 - 5.10. **Dual Prism**
 - 5.11. Cubic
 - 5.12. Truncated Tetrahedron
 - 5.13. Paper Model
6. References
7. Contact Details

Design Course

Geometry in Design

Geometrical Construction in 3D Forms

by

Prof. Ravi Mokashi Punekar and

Prof. Avinash Shide

DoD, IIT Guwahati

Source:

<http://www.dsource.in/course/geometry-design/family-3-dimensional/dual-prism>

3D Wireframe Packing:

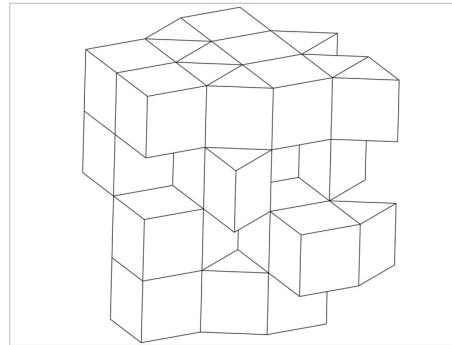

Packing Cubic Prism-Cube

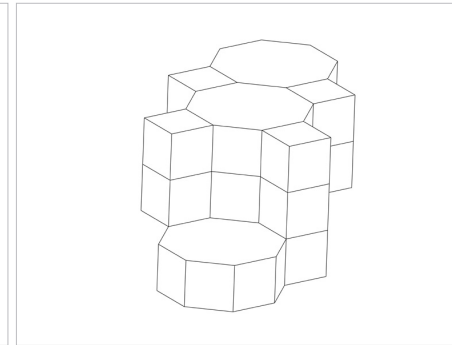

Packing Cubic Prism -
Octagonal Prism

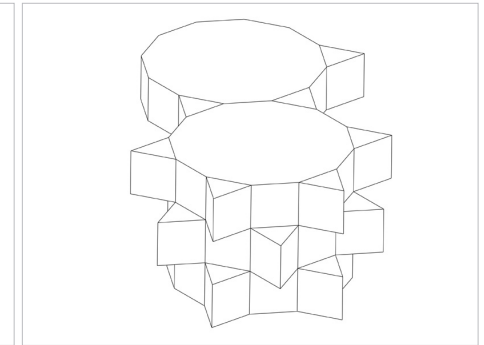

Packing Trigonal Prism -
Dodeca Prism

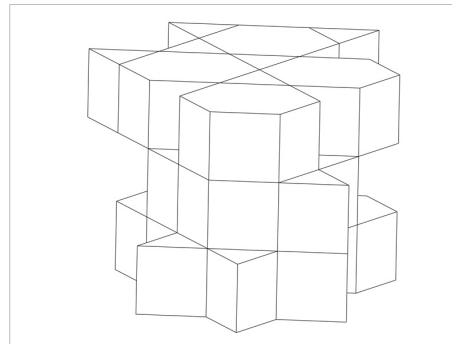

Packing Trigonal Prism -
Hexagonal Prism

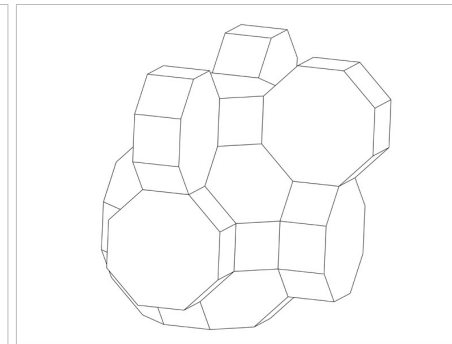

Packing Truncated Dymaxion -
Octagonal Prism

1. Introduction
2. Golden Ratio
3. Polygon - Classification - 2D
4. Concepts - 3 Dimensional
5. Family of 3 Dimensional
 - 5.1, 5.2, 5.3, 5.4, 5.5, 5.6,
 - 5.7. Dodecahedral
 - 5.8. Octahedral
 - 5.9. Self Truncate
 - 5.10. **Dual Prism**
 - 5.11. Cubic
 - 5.12. Truncated Tetrahedron
 - 5.13. Paper Model
6. References
7. Contact Details

Design Course

Geometry in Design

Geometrical Construction in 3D Forms

by

Prof. Ravi Mokashi Punekar and

Prof. Avinash Shide

DoD, IIT Guwahati

Source:

<http://www.dsource.in/course/geometry-design/family-3-dimensional/cubic>

Cubic

2D Construction:

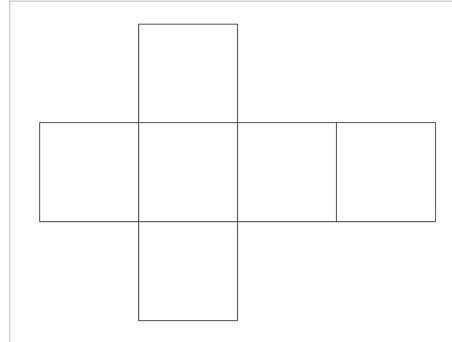

Cubic Prism or Cube

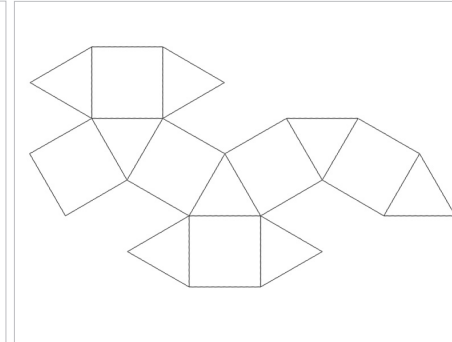

Dymaxion

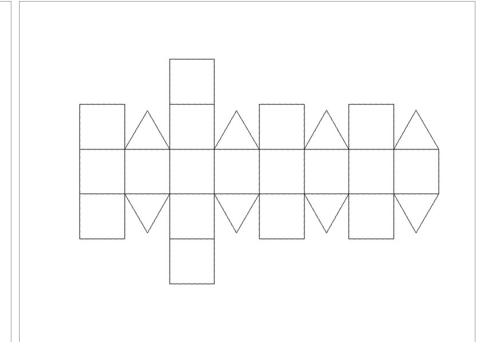

Rhombicuboctahedron

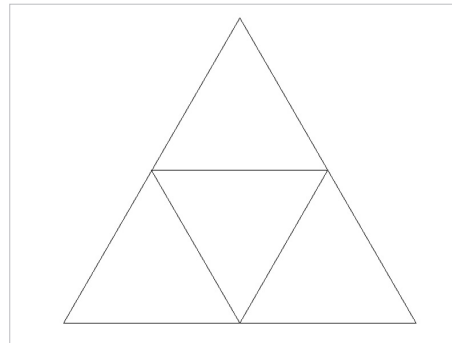

Tetrahedron

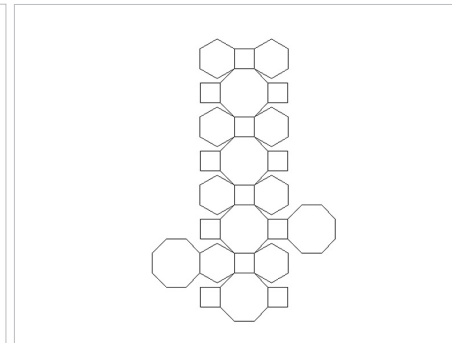

Truncated Cuboctahedron

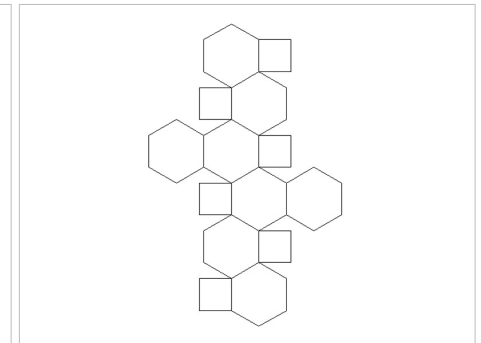

Truncated Octahedron

1. Introduction
2. Golden Ratio
3. Polygon - Classification - 2D
4. Concepts - 3 Dimensional
5. Family of 3 Dimensional
 - 5.1, 5.2, 5.3, 5.4, 5.5, 5.6,
 - 5.7. Dodecahedral
 - 5.8. Octahedral
 - 5.9. Self Truncate
 - 5.10. Dual Prism
 - 5.11. **Cubic**
 - 5.12. Truncated Tetrahedron
 - 5.13. Paper Model
6. References
7. Contact Details

Design Course

Geometry in Design

Geometrical Construction in 3D Forms

by

Prof. Ravi Mokashi Punekar and

Prof. Avinash Shide

DoD, IIT Guwahati

Source:

<http://www.dsource.in/course/geometry-design/family-3-dimensional/cubic>

1. Introduction
2. Golden Ratio
3. Polygon - Classification - 2D
4. Concepts - 3 Dimensional
5. Family of 3 Dimensional
 - 5.1, 5.2, 5.3, 5.4, 5.5, 5.6,
 - 5.7. Dodecahedral
 - 5.8. Octahedral
 - 5.9. Self Truncate
 - 5.10. Dual Prism
 - 5.11. **Cubic**
 - 5.12. Truncated Tetrahedron
 - 5.13. Paper Model
6. References
7. Contact Details

3D Rendering:

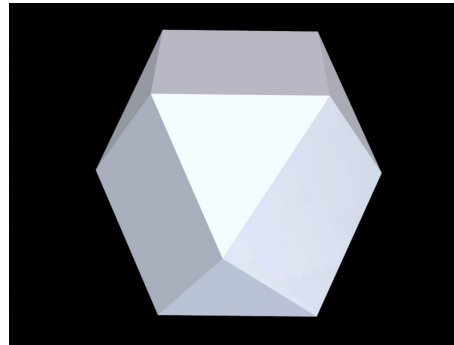

Cubeoctahedron (dymaxion)

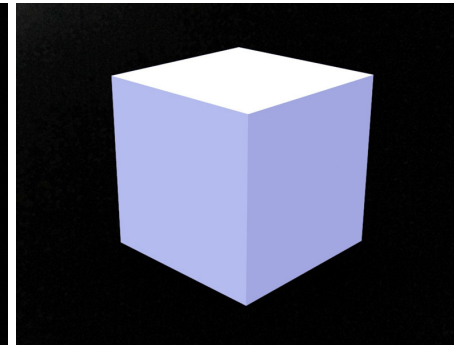

Cubic Prism or Cube

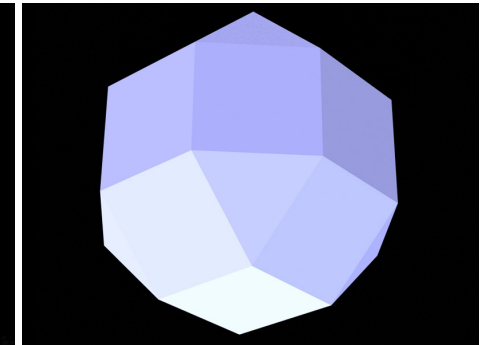

Rhombicuboctahedron

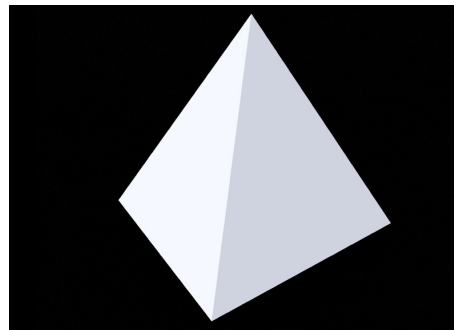

Tetrahedron

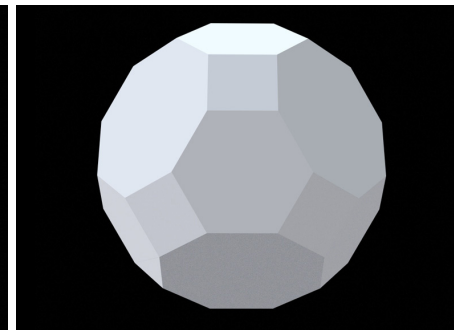

Truncated Cubeoctahedron

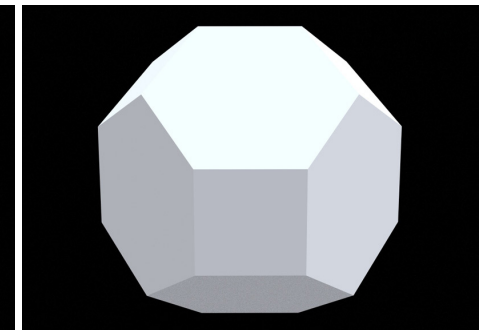

Truncated Octahedron

3D Rendering Packing:

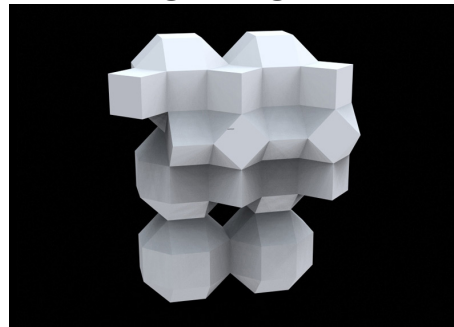

Packing Cube - Dymaxion - Rhombicuboctahedron

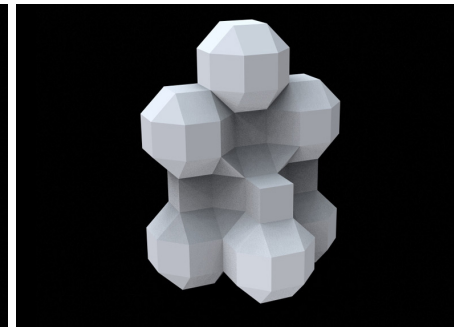

Packing Cube - Tetrahedron - Rhombicuboctahedron

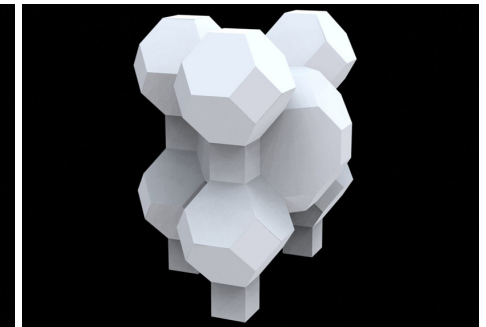

Packing Cube - Truncated Octahedron - Truncated Cubeoctahedron

Design Course

Geometry in Design

Geometrical Construction in 3D Forms

by

Prof. Ravi Mokashi Punekar and

Prof. Avinash Shide

DoD, IIT Guwahati

Source:

<http://www.dsource.in/course/geometry-design/family-3-dimensional/cubic>

1. Introduction
2. Golden Ratio
3. Polygon - Classification - 2D
4. Concepts - 3 Dimensional
5. Family of 3 Dimensional
 - 5.1, 5.2, 5.3, 5.4, 5.5, 5.6,
 - 5.7. Dodecahedral
 - 5.8. Octahedral
 - 5.9. Self Truncate
 - 5.10. Dual Prism
 - 5.11. **Cubic**
 - 5.12. Truncated Tetrahedron
 - 5.13. Paper Model
6. References
7. Contact Details

3D Wireframe:

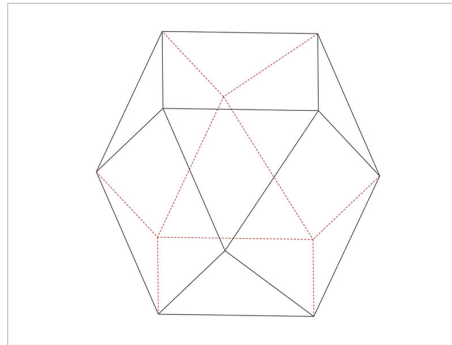

Cubeoctahedron (dymaxion)

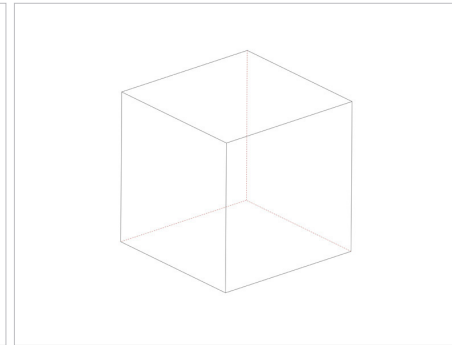

Cubic Prism or Cube

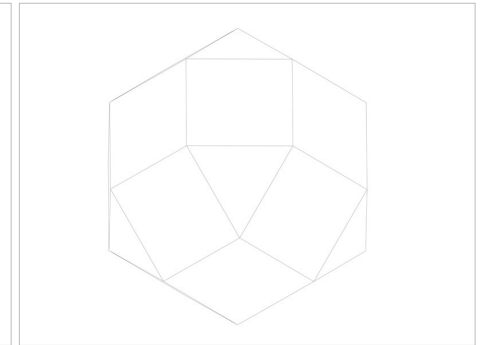

Rhombicuboctahedron

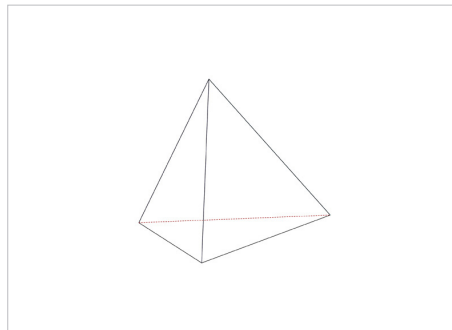

Tetrahedron

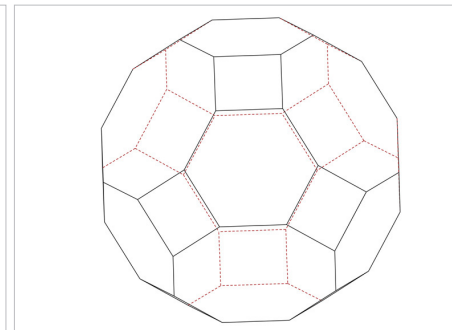

Truncated Dymaxion

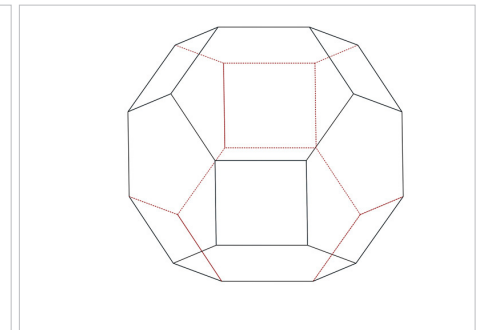

Truncated Octahedron

2D Construction:

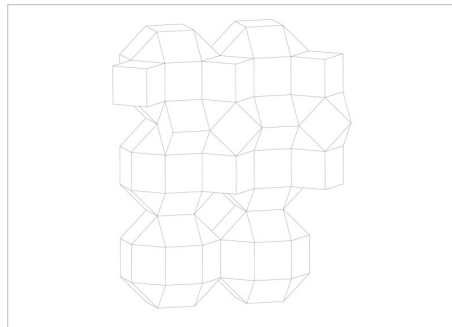

Packing Cube - Dymaxion - Rhombicuboctahedron

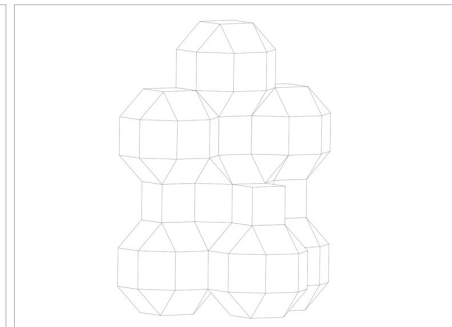

Packing Cube - Tetrahedron - Rhombicuboctahedron

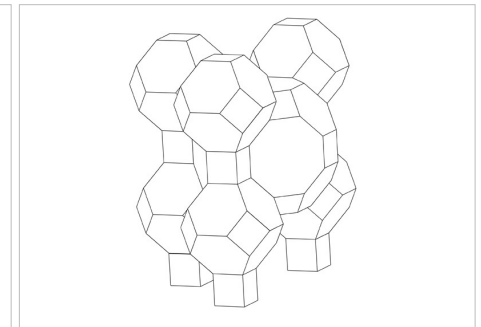

Packing Cube - Truncated Octahedron - Truncated Cuboctahedron

Design Course

Geometry in Design

Geometrical Construction in 3D Forms

by

Prof. Ravi Mokashi Punekar and

Prof. Avinash Shide

DoD, IIT Guwahati

Source:

<http://www.dsource.in/course/geometry-design/family-3-dimensional/truncated-tetrahedron>

Truncated Tetrahedron

2D Construction:

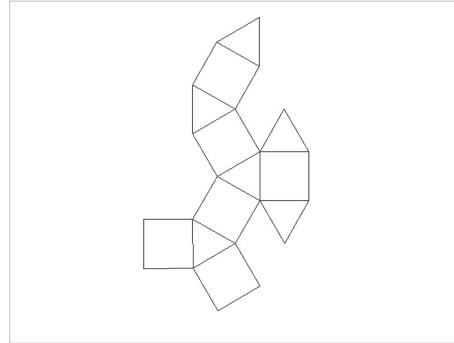

Dymaxion

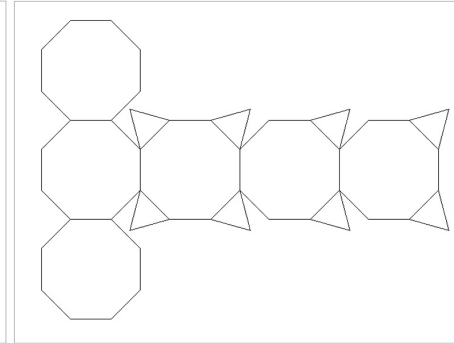

Truncated Cube

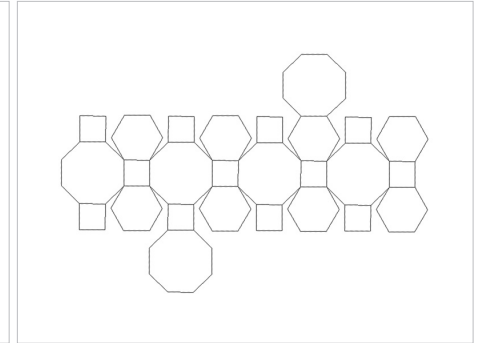

Truncated Cuboctahedron

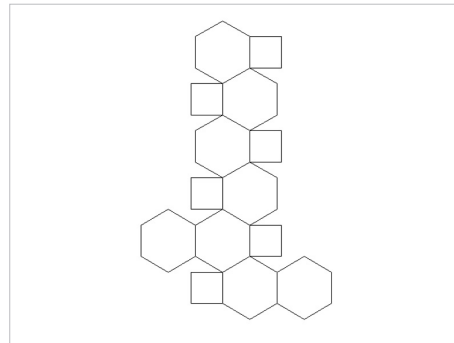

Truncated Octahedron

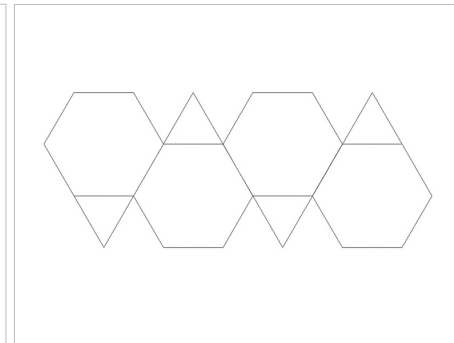

Truncated Tetrahedron

1. Introduction
2. Golden Ratio
3. Polygon - Classification - 2D
4. Concepts - 3 Dimensional
5. Family of 3 Dimensional
 - 5.1, 5.2, 5.3, 5.4, 5.5, 5.6,
 - 5.7. Dodecahedral
 - 5.8. Octahedral
 - 5.9. Self Truncate
 - 5.10. Dual Prism
 - 5.11. Cubic
 - 5.12. **Truncated Tetrahedron**
 - 5.13. Paper Model
6. References
7. Contact Details

Design Course

Geometry in Design

Geometrical Construction in 3D Forms

by

Prof. Ravi Mokashi Punekar and

Prof. Avinash Shide

DoD, IIT Guwahati

Source:

<http://www.dsource.in/course/geometry-design/family-3-dimensional/truncated-tetrahedron>

3D Rendering:

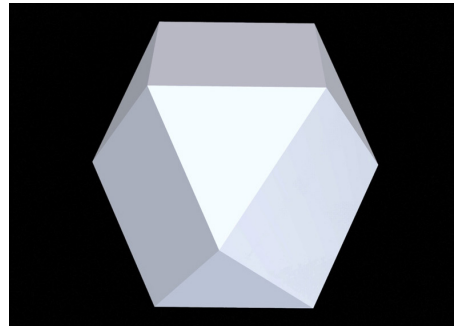

Cubeoctahedron
(dymaxion)

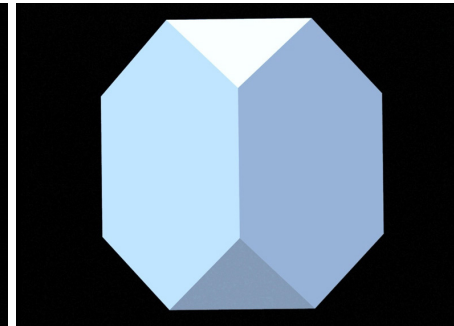

Produced Truncated Tetrahedron

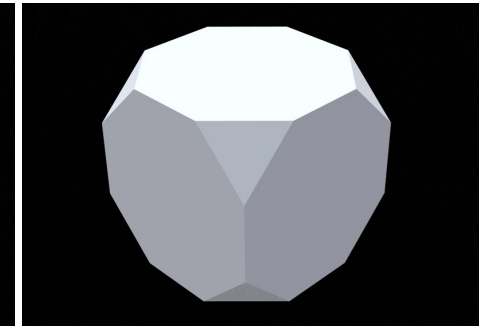

Truncated Cube

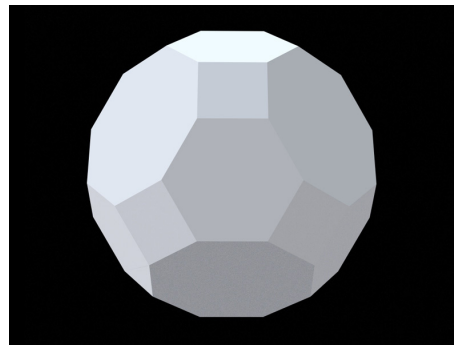

Truncated Cuboctahedron

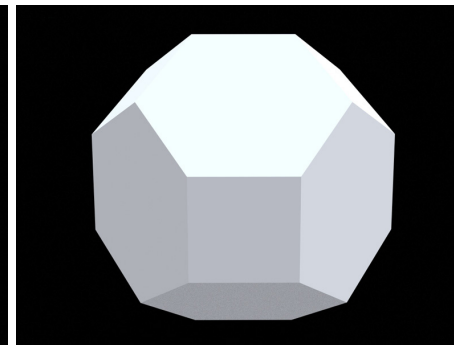

Truncated Octahedron

3D Rendering Packing:

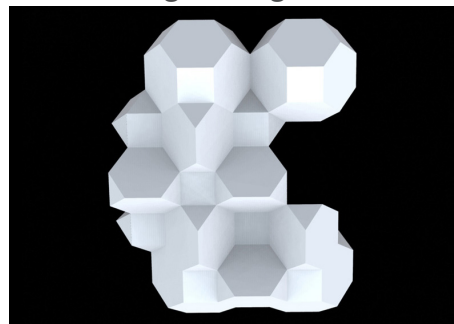

Packing Truncated Tetrahedrin - Dymaxion - Truncated Octahedron

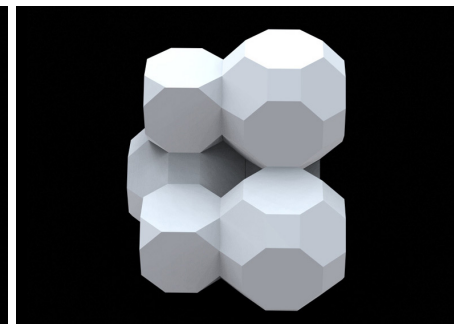

Packing Truncated Tetrahedron - Truncated Cube - Truncated Cuboctahedron

1. Introduction
2. Golden Ratio
3. Polygon - Classification - 2D
4. Concepts - 3 Dimensional
5. Family of 3 Dimensional
 - 5.1, 5.2, 5.3, 5.4, 5.5, 5.6,
 - 5.7. Dodecahedral
 - 5.8. Octahedral
 - 5.9. Self Truncate
 - 5.10. Dual Prism
 - 5.11. Cubic
 - 5.12. **Truncated Tetrahedron**
 - 5.13. Paper Model
6. References
7. Contact Details

Design Course

Geometry in Design

Geometrical Construction in 3D Forms

by

Prof. Ravi Mokashi Punekar and

Prof. Avinash Shide

DoD, IIT Guwahati

Source:

<http://www.dsource.in/course/geometry-design/family-3-dimensional/truncated-tetrahedron>

1. Introduction
2. Golden Ratio
3. Polygon - Classification - 2D
4. Concepts - 3 Dimensional
5. Family of 3 Dimensional
 - 5.1, 5.2, 5.3, 5.4, 5.5, 5.6,
 - 5.7. Dodecahedral
 - 5.8. Octahedral
 - 5.9. Self Truncate
 - 5.10. Dual Prism
 - 5.11. Cubic
 - 5.12. **Truncated Tetrahedron**
 - 5.13. Paper Model
6. References
7. Contact Details

3D Wireframe:

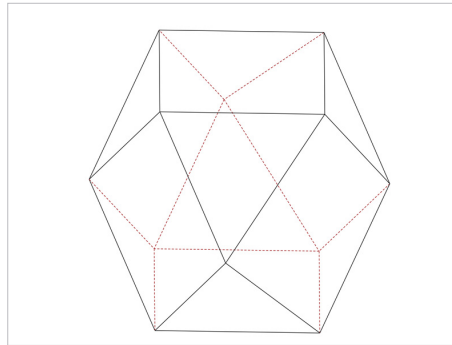

Cubeoctahedron (dymaxion)

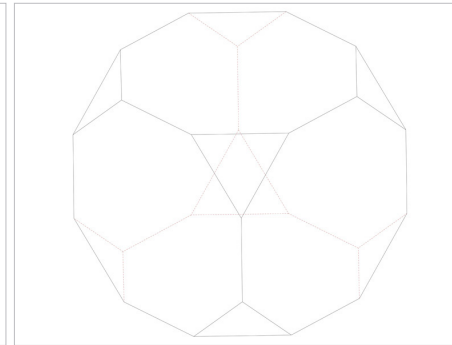

Truncated Cube

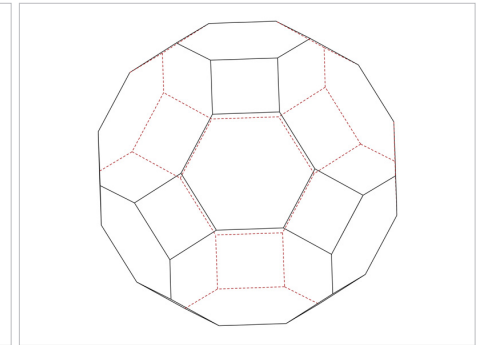

Truncated Dymaxion

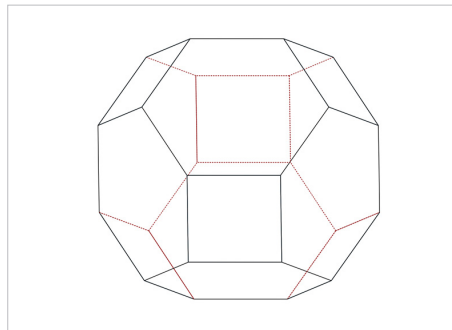

Truncated Octahedron

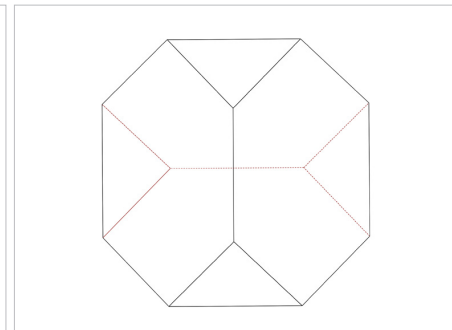

Truncated Tetrahedron

3D Wireframe Packing:

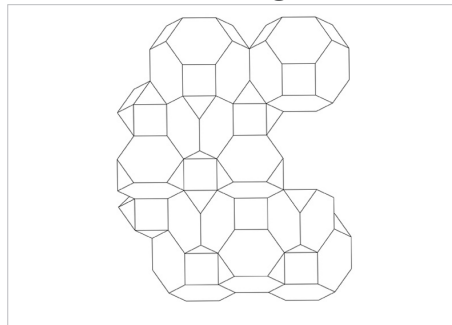

Packing Truncated Tetrahedron -
Dymaxion - Truncated Octahedron

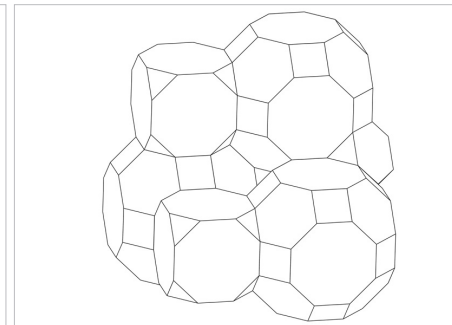

Packing Truncated Tetrahedron -
Truncated Cube - Truncated
Cubeoctahedron

Design Course

Geometry in Design

Geometrical Construction in 3D Forms

by

Prof. Ravi Mokashi Punekar and

Prof. Avinash Shide

DoD, IIT Guwahati

Source:

<http://www.dsource.in/course/geometry-design/family-3-dimensional/paper-model>

Paper Model

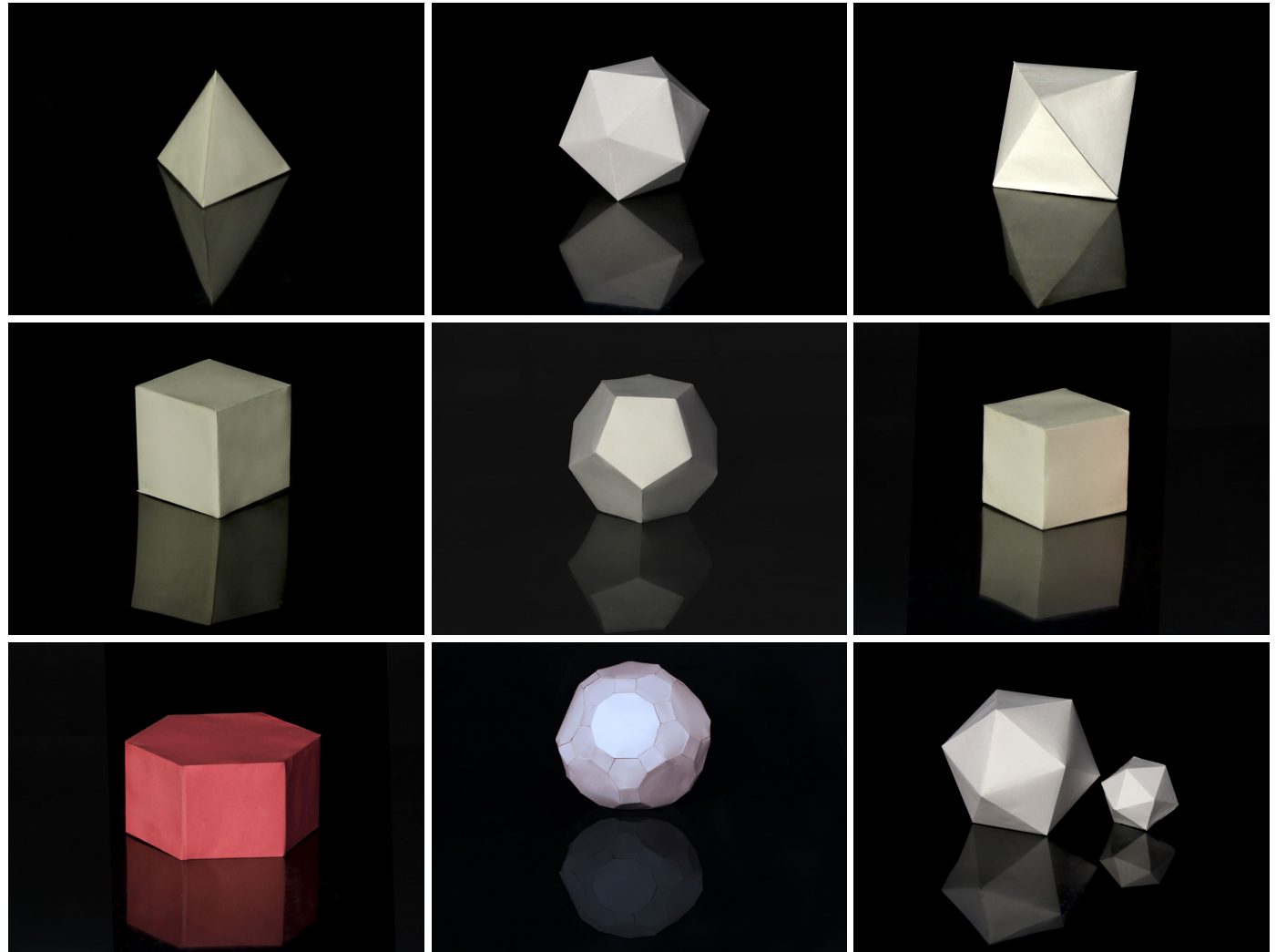

1. Introduction
2. Golden Ratio
3. Polygon - Classification - 2D
4. Concepts - 3 Dimensional
5. Family of 3 Dimensional
 - 5.1, 5.2, 5.3, 5.4, 5.5, 5.6,
 - 5.7. Dodecahedral
 - 5.8. Octahedral
 - 5.9. Self Truncate
 - 5.10. Dual Prism
 - 5.11. Cubic
 - 5.12. Truncated Tetrahedron
 - 5.13. **Paper Model**
6. References
7. Contact Details

Design Course

Geometry in Design

Geometrical Construction in 3D Forms

by

Prof. Ravi Mokashi Punekar and

Prof. Avinash Shide

DoD, IIT Guwahati

Source:

<http://www.dsource.in/course/geometry-design/family-3-dimensional/paper-model>

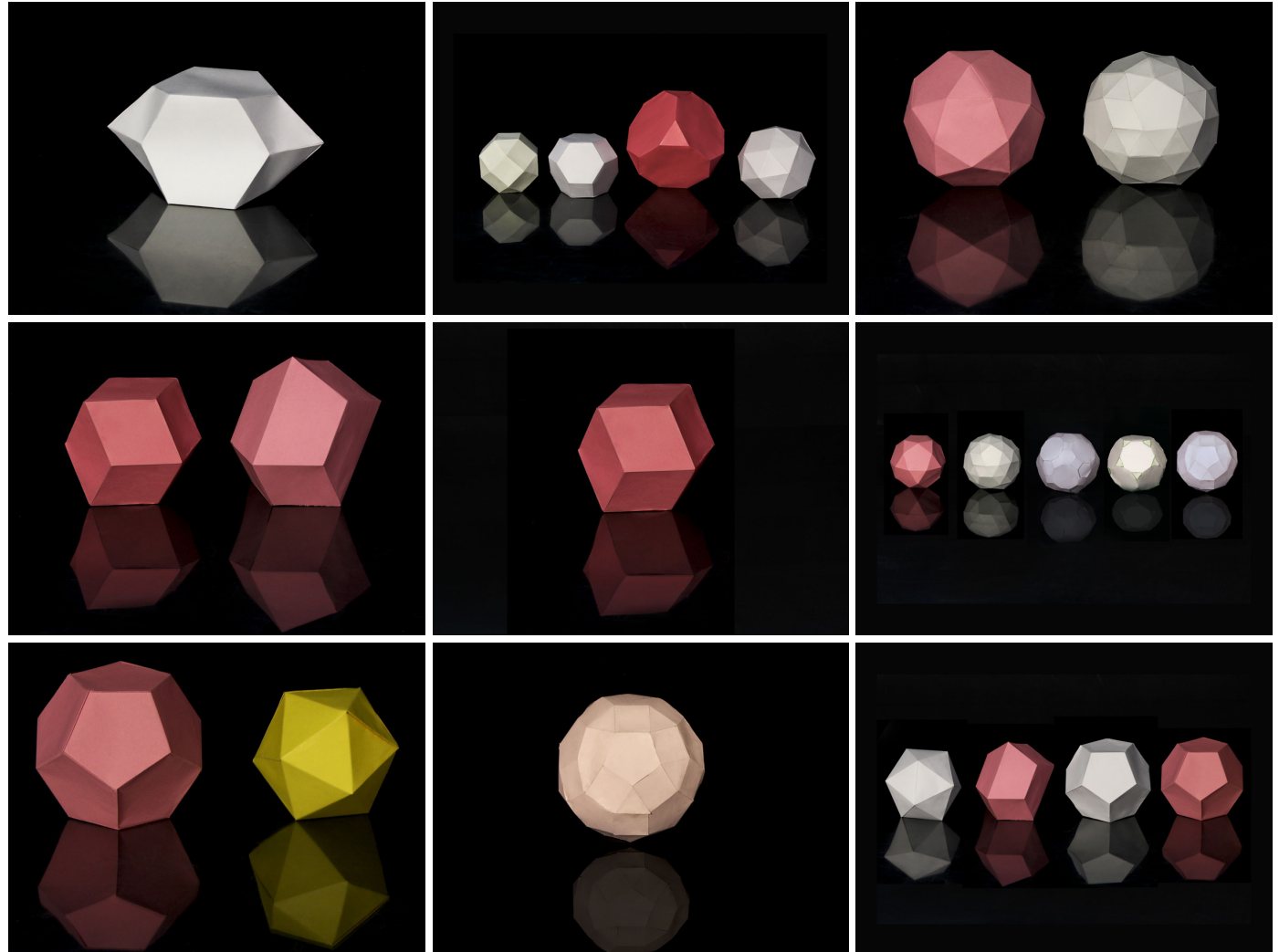

1. Introduction

2. Golden Ratio

3. Polygon - Classification - 2D

4. Concepts - 3 Dimensional

5. Family of 3 Dimensional

5.1, 5.2, 5.3, 5.4, 5.5, 5.6,

5.7. Dodecahedral

5.8. Octahedral

5.9. Self Truncate

5.10. Dual Prism

5.11. Cubic

5.12. Truncated Tetrahedron

5.13. **Paper Model**

6. References

7. Contact Details

Design Course

Geometry in Design

Geometrical Construction in 3D Forms

by

Prof. Ravi Mokashi Punekar and

Prof. Avinash Shide

DoD, IIT Guwahati

Source:

<http://www.dsource.in/course/geometry-design/references>

References

Reading List:

1. Kimberley Elam (2001) Geometry in Design – Studies in Proportion and Composition, New York: Princeton Architectural Press.
2. Critchlow Kieth (1969 rpt 2000) Order in Space – A Design Source Book, London: Thames & Hudson.
3. Elam Kemberly, Geometry in Design, Princeton Architectural Press, New York., 2001.
4. Akner-Koler, Three Dimensional Visual Analysis, Institutionen for Industridesign, Konftfack, Sweden, 1994.
5. Prigogine (1984) Order out of Chaos: Man's New Dialogue with Nature, Flamingo.
6. T. W. Knight (1998) Transformations in Design: a formal approach to stylistic change and innovation in visual arts, Cambridge Univ. Press.
7. R B. Fuller (1999) Your Private Sky: art, design, science, Lars Muller Pub., 1999.
8. R. Beech (2001) Origami: The complete guide to the art of paper folding, Lorenz Books.
9. Thomas D'archy (1964) Growth and Form, Phidon.

Websites

1. [Impossible world: Articles: The principles of artistic illusions](#)
2. [Tessellation -- from Wolfram MathWorld](#)

1. Introduction
2. Golden Ratio
3. Polygon - Classification - 2D
4. Concepts - 3 Dimensional
5. Family of 3 Dimensional
6. **References**
7. Contact Details

Design Course

Geometry in Design

Geometrical Construction in 3D Forms

by

Prof. Ravi Mokashi Punekar and

Prof. Avinash Shinde

DoD, IIT Guwahati

Source:

<http://www.dsource.in/course/geometry-design/contact-details>

Contact Details

This documentation for the course was done by

Professor Ravi Mokashi Punekar and

Professor Avinash Shinde at **DoD, IIT Guwahati**.

You can get in touch with

Prof. Ravi Mokashi Punekar and

Email: [mokashi\[at\]iitg.ernet.in](mailto:mokashi[at]iitg.ernet.in)

Professor Avinash Shinde

Email: savinash@iitg.ernet.in

You could write to the following address regarding suggestions and clarifications:

Helpdesk Details:

Co-ordinator

Project e-kalpa

Department of Design

Indian Institute of Technology Guwahati

North Guwahati

Guwahati 781039

Assam,

India

Phone: +91-361-2582500, +91-361-2582451

Fax: +91-361-2690762

Email: [dsource.in\[at\]gmail.com](mailto:dsource.in[at]gmail.com)

1. Introduction
2. Golden Ratio
3. Polygon - Classification - 2D
4. Concepts - 3 Dimensional
5. Family of 3 Dimensional
6. References
7. **Contact Details**