

Design Resource

## Yakshagana Puppets

String Puppets in India

by

Prof. Bibhudutta Baral, Divyadarshan C. S.,

Shruti K. and Smitha S.

NID Campus, Bengaluru

Source:

<http://www.dsource.in/resource/yakshagana-puppets>



1. Introduction
2. Tools and Raw Materials
3. Making Process
4. Products
5. Setting the Stage
6. Contact Details

Design Resource

## Yakshagana Puppets

String Puppets in India

by

Prof. Bibhudutta Baral, Divyadarshan C. S.,

Shruti K. and Smitha S.

NID Campus, Bengaluru

Source:

<http://www.dsource.in/resource/yakshagana-puppets/introduction>

## Introduction

Marionette also known as string puppets, are a great form of entertainment to the young and old. These puppets have over 3000 years of history, which is mentioned in the books of Aristotle and Plato. String puppets were not only the form of entertainment but there were also the medium of delivering strong messages to common people, emperors and many times people believed gods come down to earth in the forms of puppets and communicated with public. Marionette form of puppetry is different from other kinds of puppets, these puppets are controlled using strings from above, allowing the puppet to have total freedom of movement compared to other forms of puppetry. Puppeteer (person controlling the puppets) owns great skill and technique which is required to bring life into the puppet.

Throughout the history, puppets have been found in use by different countries for different purposes. Many times marionettes were used to communicate the message, which could not be communicated directly through humans. For example, a king would ask the marionettes leader to perform a play/story which will help in correcting his children or his wife about their irresponsible activity, during the program wife or the children will find out their mistake and are given a chance to correct it. This way the common public is entertained and irresponsible activity of a person was also corrected. During the play, puppeteers will also mention about the latest activity happening in the present and other kingdoms.

Puppeteers were always considered of high standard among the common public, they were considered wise and educated because they had the skill to deliver and communicate messages to the most uneducated part of the society. One could easily say that, marionettes were the actors of ancient times. Common men used puppets as a medium to inform their feelings about the governing kingdom. It was considered an offense to directly oppose the rules made by the royal kingdom, punishment for such an offense was beheading. So this way puppets could say anything to the kingdom in the form of comedy or entertainment and without any disrespect. As a puppet, it need not to follow any of the rules and regulations made for the human actors.

Puppets have no restriction to do any characters with well decorated with colorful cloth and jewelry, silver was extensively used because it provides shine even under dull light, whereas humans were allowed to perform with lots of restrictions.

### 1. Introduction

### 2. Tools and Raw Materials

### 3. Making Process

### 4. Products

### 5. Setting the Stage

### 6. Contact Details

Design Resource

## Yakshagana Puppets

String Puppets in India

by

Prof. Bibhudutta Baral, Divyadarshan C. S.,

Shruti K. and Smitha S.

NID Campus, Bengaluru

### Source:

<http://www.dsource.in/resource/yakshagana-puppets/introduction>

### String Puppets in India

Even though there are no written documents, but it is strongly believed that the earliest puppet show was held in the border of Rajasthan and Gujarat which was known as “Kathputli” (string puppets) and it was operated by the community called Bhats. People of bhats community have travelled to different parts of India like West Bengal, Assam, Orissa, Tripura, Manipur, Maharashtra, Andhra Pradesh, Kerala and Karnataka. It is said that 1st ever string puppet show, which was held in the border of Rajasthan and Gujarat was based upon the stories of king Vikramaditya, who had 32 stories associated with him, so the 1st show consisted of 32 puppets with was operated with help of strings.

Development of string puppets in Karnataka are known as Sutrada gombatta in the Mysore area and yakshagana gombatta in coastal. These puppets are highly inspired by the art form of yakshagana (a unique theater play well known in Karnataka) they are highly decorated with cotton fabric and jewelry. Traditionally, puppets were controlled by the “Bhagavathar” (the holder of strings) who had amazing skills in controlling the puppets through strings and were also great musician, music composer and excellent story teller handling all together. Due to the popularity and demand, groups were made in puppeteers and musician, where bhagavathar took the position of musician.

The stage is buildup 6 feet from the ground, using wooden planks. Width of the stage is 15 x 10 feet. The outer area the stage is covered with cotton fabric. The wooden frame is covered with black color cotton back drop. The puppeteers stand behind the back drop and use both the hand to control the puppet with the help of strings. Puppet show starts with the blessing of lord Ganesh, it is believed in Hindu religion that worshipping lord Ganesh keeps all the hurdle away, and then main character enters the stage. Generally yakshagana puppets are controlled using 6 strings, each pair of strings are used for head, legs and for hands and each puppet weigh up to 20 kgs. Three types of wooden controller are used and each one has 2 strings attached. The first controller is known as Lord Maheshwara (the destroyer) Middle controller is considered as lord Brahma (the creator) which is used to balance the puppets, last controller is known as Vishnu (the operator). Puppet movements are controlled using 7 tala's (rhythmic notes). Yakshagana puppetry consist of 7 talas, which are known as adi tala, eka tala, jampe tala, trivde tala, maate tala, rupak tala and asta tala.

Puppets has eleven different parts which are joined together. The movement of the puppet match the raga and tala sung by the bhagavathar. Up to 5 puppeteer's stand on the stage controlling about 5 to 6 puppets at a time, the main character is controlled by the master puppeteer. Yakshagana puppet team consist of 15 team member. Due to the proper combination between the puppeteer and bhagavathar, the movement of puppet resembles the movement of yakshagana artisans.

### 1. Introduction

### 2. Tools and Raw Materials

### 3. Making Process

### 4. Products

### 5. Setting the Stage

### 6. Contact Details



Design Resource

## Yakshagana Puppets

String Puppets in India

by

Prof. Bibhudutta Baral, Divyadarshan C. S.,

Shruti K. and Smitha S.

NID Campus, Bengaluru

Source:

<http://www.dsource.in/resource/yakshagana-puppets/introduction>

Yakshagana puppets has a history of 5 generations working endlessly since mid of 16th century by “Kamath” family from a small village of Kundapura in south canara. This family has attained international recognition with many awards. At present Mr.Bhaskar Kamath is a puppeteer running this folk art as 6th generation from Kamath family and has trained many youngsters. Kamath family can be contacted through their website, [www.yakshaganapuppets.org](http://www.yakshaganapuppets.org)



All the puppets are arranged and kept ready for the show.

1. Introduction
2. Tools and Raw Materials
3. Making Process
4. Products
5. Setting the Stage
6. Contact Details



Design Resource

## Yakshagana Puppets

String Puppets in India

by

Prof. Bibhudutta Baral, Divyadarshan C. S.,

Shruti K. and Smitha S.

NID Campus, Bengaluru

Source:

<http://www.dsource.in/resource/yakshagana-puppets/introduction>

### 1. Introduction

2. Tools and Raw Materials

3. Making Process

4. Products

5. Setting the Stage

6. Contact Details



One of the puppet characters, named a brahmin-juggler.



Artisan arranges the parts of the puppet.

Design Resource

## Yakshagana Puppets

String Puppets in India

by

Prof. Bibhudutta Baral, Divyadarshan C. S.,

Shruti K. and Smitha S.

NID Campus, Bengaluru

Source:

<http://www.dsource.in/resource/yakshagana-puppets/introduction>

1. Introduction
2. Tools and Raw Materials
3. Making Process
4. Products
5. Setting the Stage
6. Contact Details



Artisan playing the Rajasthani puppet.



Design Resource

## Yakshagana Puppets

String Puppets in India

by

Prof. Bibhudutta Baral, Divyadarshan C. S.,

Shruti K. and Smitha S.

NID Campus, Bengaluru

Source:

<http://www.dsource.in/resource/yakshagana-puppets/introduction>

1. Introduction
2. Tools and Raw Materials
3. Making Process
4. Products
5. Setting the Stage
6. Contact Details



Strings attached to the puppet are organized properly.



Puppeteer with his puppet.



Design Resource

## Yakshagana Puppets

String Puppets in India

by

Prof. Bibhudutta Baral, Divyadarshan C. S.,

Shruti K. and Smitha S.

NID Campus, Bengaluru

Source:

<http://www.dsource.in/resource/yakshagana-puppets/introduction>

1. Introduction
2. Tools and Raw Materials
3. Making Process
4. Products
5. Setting the Stage
6. Contact Details



Drum player tune his drum for the show.



Puppeteer explaining how the puppet is played with the strings.



Design Resource

## Yakshagana Puppets

String Puppets in India

by

Prof. Bibhudutta Baral, Divyadarshan C. S.,

Shruti K. and Smitha S.

NID Campus, Bengaluru

Source:

<http://www.dsource.in/resource/yakshagana-puppets/introduction>



Audience watching the puppet show.

1. Introduction
2. Tools and Raw Materials
3. Making Process
4. Products
5. Setting the Stage
6. Contact Details

Design Resource

## Yakshagana Puppets

String Puppets in India

by

Prof. Bibhudutta Baral, Divyadarshan C. S.,

Shruti K. and Smitha S.

NID Campus, Bengaluru

Source:

<http://www.dsource.in/resource/yakshagana-puppets/tools-and-raw-materials>

## Tools and Raw Materials

Following are the tools and raw materials used for the process of Yakshagana Puppets:

- **Wood:** Milk wood/alle mara (bana tree) is used to make the face, hands and feet of the puppet and also used to make the controller.
- **Cotton Fabric:** is used to make the body part like neck, arms, legs and chest.
- **Recycled/Used Cloth:** Used as a filling material.
- **Strings:** Copper or brass strings are connected to parts of the body and the controller.
- **Natural Colors:** Used for coloring the puppets.
- **Needle and Thread:** Used for stitching the cotton fabric and also used for joining the parts.



Different types of tools used to shape the wood into a puppet.

1. Introduction
2. **Tools and Raw Materials**
3. Making Process
4. Products
5. Setting the Stage
6. Contact Details



Design Resource

## Yakshagana Puppets

String Puppets in India

by

Prof. Bibhudutta Baral, Divyadarshan C. S.,

Shruti K. and Smitha S.

NID Campus, Bengaluru

Source:

<http://www.dsource.in/resource/yakshagana-puppets/tools-and-raw-materials>



Enamel colors are used to color the puppets.



Chisels are used to carve the wood to desired shape.

1. Introduction

2. **Tools and Raw Materials**

3. Making Process

4. Products

5. Setting the Stage

6. Contact Details



Milk Wood is the foremost material used for making the puppet.

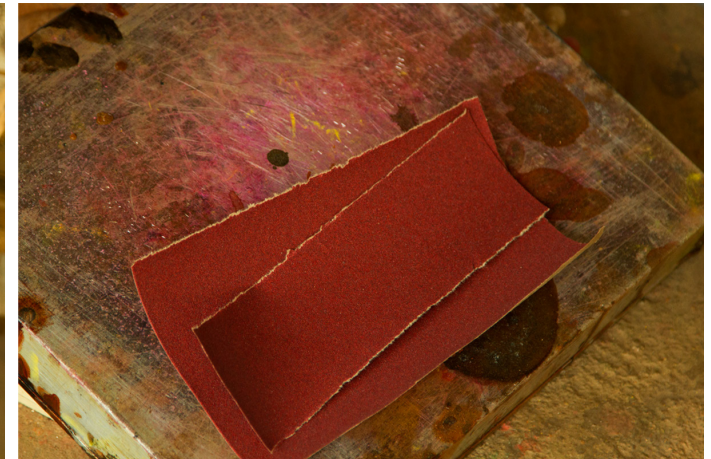

The surface of the wood is smoothed using sand paper.



Design Resource

## Yakshagana Puppets

String Puppets in India

by

Prof. Bibhudutta Baral, Divyadarshan C. S.,

Shruti K. and Smitha S.

NID Campus, Bengaluru

Source:

<http://www.dsource.in/resource/yakshagana-puppets/tools-and-raw-materials>

1. Introduction
2. **Tools and Raw Materials**
3. Making Process
4. Products
5. Setting the Stage
6. Contact Details



Decorative ornaments are used to embellish the puppet.

Design Resource

## Yakshagana Puppets

String Puppets in India

by

Prof. Bibhudutta Baral, Divyadarshan C. S.,

Shruti K. and Smitha S.

NID Campus, Bengaluru

### Source:

<http://www.dsource.in/resource/yakshagana-puppets/making-process>

## Making Process

Planning is very important step for any work, puppet show or puppet making is also planned well in advance and the puppet characters are pre-visualized depending upon the show it is going to performer, each story requires a unique set of puppets to represent the idea of a puppeteer which may depicts daily/modern life style the puppets or mythological puppets. It is also important to plan out the venue of performance. If the performance is for the school children and inside the school, the puppets can be simple and light weight but if the performance is outside for the general public, puppets have to be well decorated and highly durable to the weather and climatic conditions. Depending on the story to be performed, it may take about a week to a month to construct a puppet.

Puppet making generally consist of 3 elements: a puppet carving, attachment of strings and puppet control device. Puppet figure of the puppet is a representation of a human, animal and any other elements which is found in nature and can be used in the puppet shows. Using mechanical design, it is easy to determine the types of joints required to connect each parts of puppet such as limbs, features like blinking of eye, movable mouthpieces and palms of a human figure. The difficulty increase when puppet consist more segments, adding torso helps in turning a bowing motions. Due to the versatility of marionette joints, degree of freedom (DOF) is provided like one degree, 2 and 3 degrees of freedom respectively is allowed.

Main body part of the puppet is built using Milk wood (alle mara), small blocks of milk wood is chiseled to make the required body parts like face, hands, feet and are attached to other body parts with help of nails. Area between shoulder to palm and waist till foot is filled with soft material like cushion/used cloth or cotton waste as filler for hands and legs. Colorful cotton fabric is used as clothing and ornaments to dress as per the plan and strings are attached to control

**Attachment of Strings:** With the help of strings, puppeteers control the puppet remotely. Strings help in producing life like movement to the puppets that behaves like actuators. Earlier, leather was used as a string to control the puppets, but due to the elasticity nature of leather, accurate movements could not be made, hence multi thread embroidery string replaced and helped in producing the accurate movements.

Strings are classified based on their functions, strings for support, strings for controlling the movement and strings for extra effects. Supporting strings holds the weight of the puppet and helps to keep the puppet stationary during the play, these strings are attached to the torso of puppets. The remaining strings are connected based on these strings to arms, legs and head helps in controlling the movement of the puppets. Few puppets, which have more joints and moveable parts may consist up to 50 strings, with help of these strings extra effects like picking cups, drinking of tea, pulling out and holding back the sword, etc can be achieved. These strings are attached to the puppet with helps of nails.

### 1. Introduction

### 2. Tools and Raw Materials

### 3. Making Process

### 4. Products

### 5. Setting the Stage

### 6. Contact Details



Design Resource

## Yakshagana Puppets

String Puppets in India

by

Prof. Bibhudutta Baral, Divyadarshan C. S.,

Shruti K. and Smitha S.

NID Campus, Bengaluru

Source:

<http://www.dsource.in/resource/yakshagana-puppets/making-process>

Puppet Controller: The strings of puppet are attached to the wooden control, with the help of wooden controller, puppeteer controls the puppet. Controller is made of simple wooden plank (small and handy) or any other complex form, depending upon the number of strings to be attached.

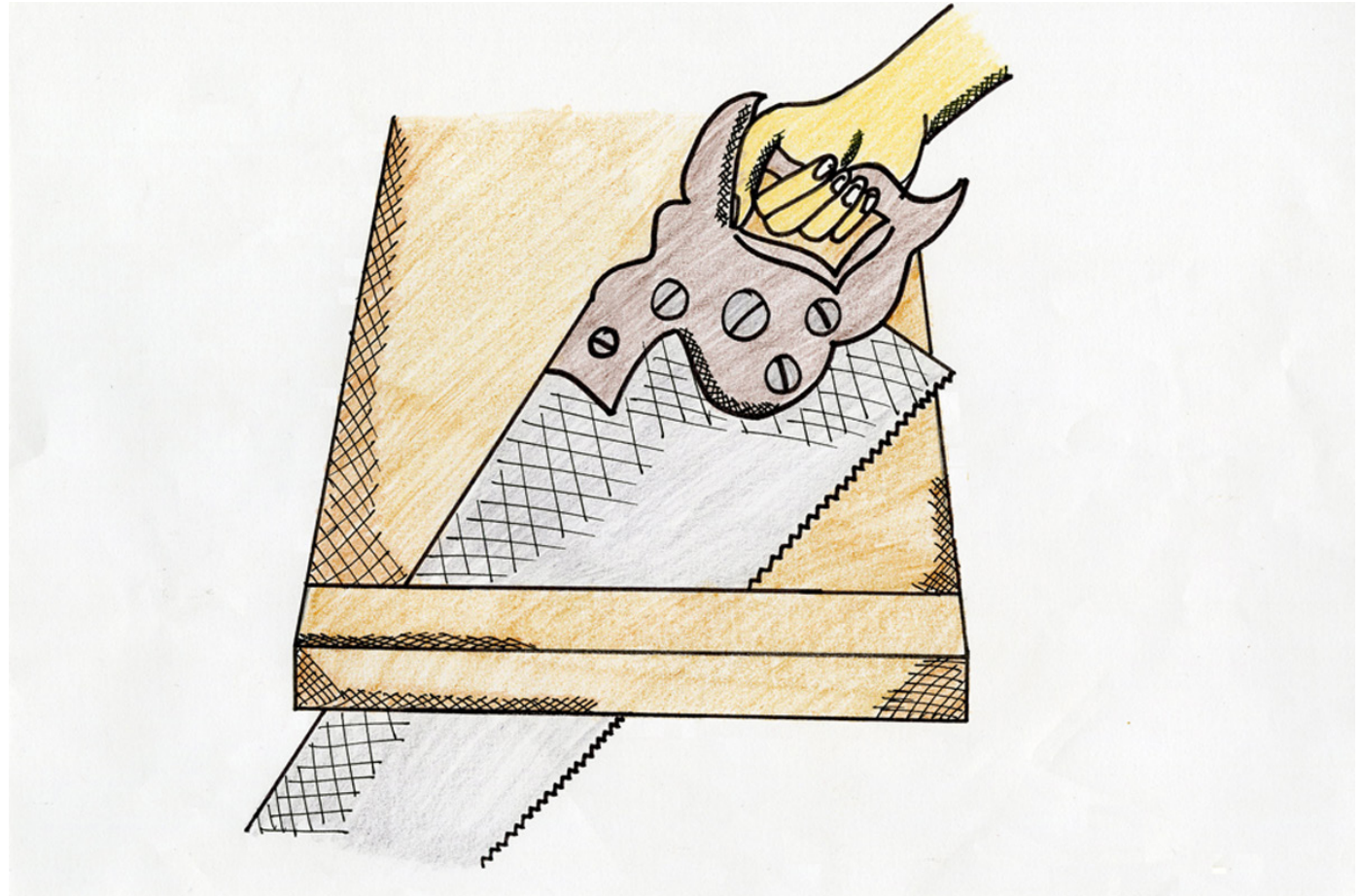

Wood is cut into required size and shape using hand saw.

1. Introduction
2. Tools and Raw Materials
3. **Making Process**
4. Products
5. Setting the Stage
6. Contact Details

Design Resource

## Yakshagana Puppets

String Puppets in India

by

Prof. Bibhudutta Baral, Divyadarshan C. S.,

Shruti K. and Smitha S.

NID Campus, Bengaluru

Source:

<http://www.dsource.in/resource/yakshagana-puppets/making-process>

1. Introduction
2. Tools and Raw Materials
3. **Making Process**
4. Products
5. Setting the Stage
6. Contact Details

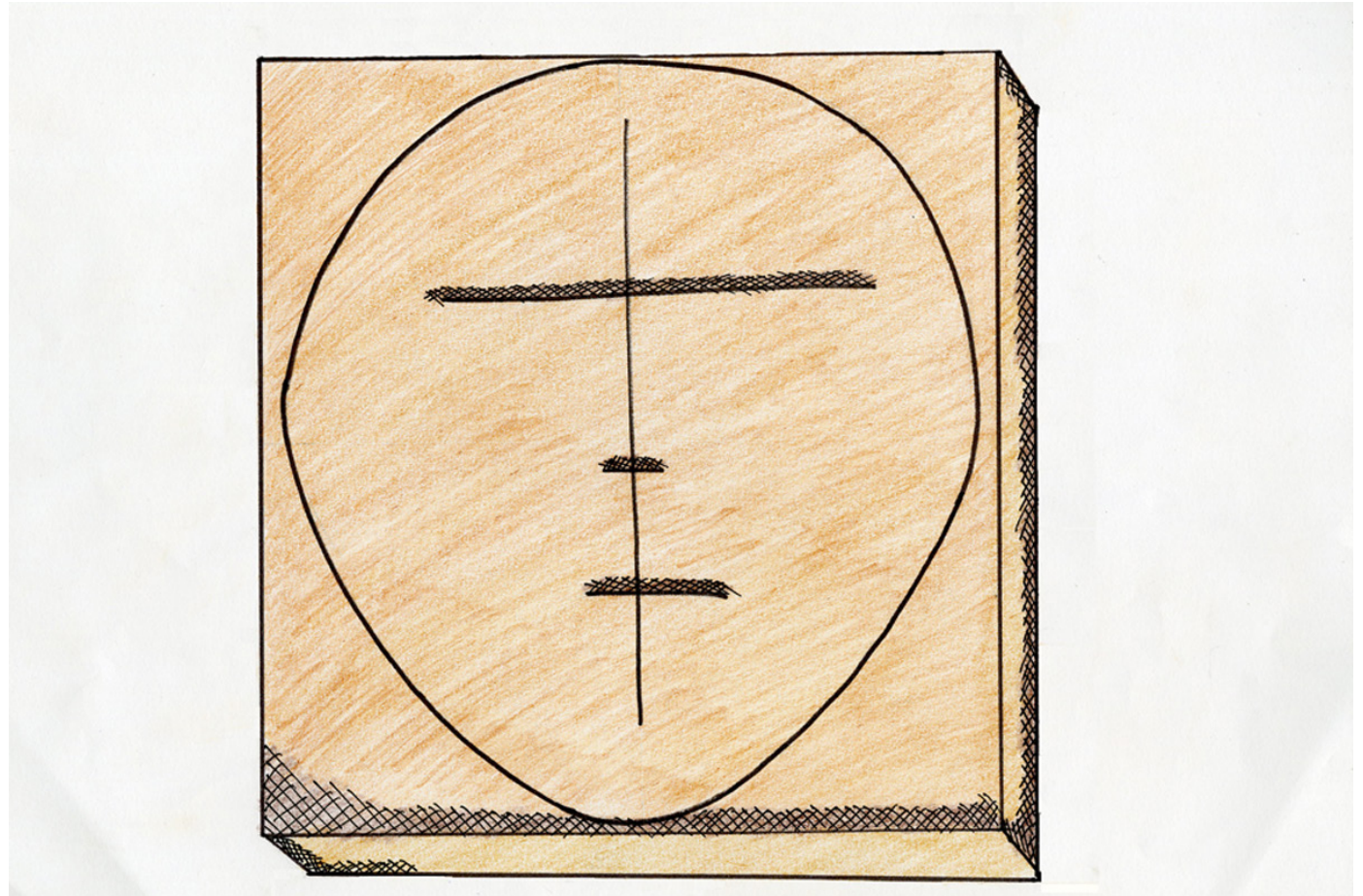

Basic sketch of the puppet's face is drawn on the wood.



Design Resource

## Yakshagana Puppets

String Puppets in India

by

Prof. Bibhudutta Baral, Divyadarshan C. S.,

Shruti K. and Smitha S.

NID Campus, Bengaluru

Source:

<http://www.dsource.in/resource/yakshagana-puppets/making-process>

1. Introduction
2. Tools and Raw Materials
3. **Making Process**
4. Products
5. Setting the Stage
6. Contact Details

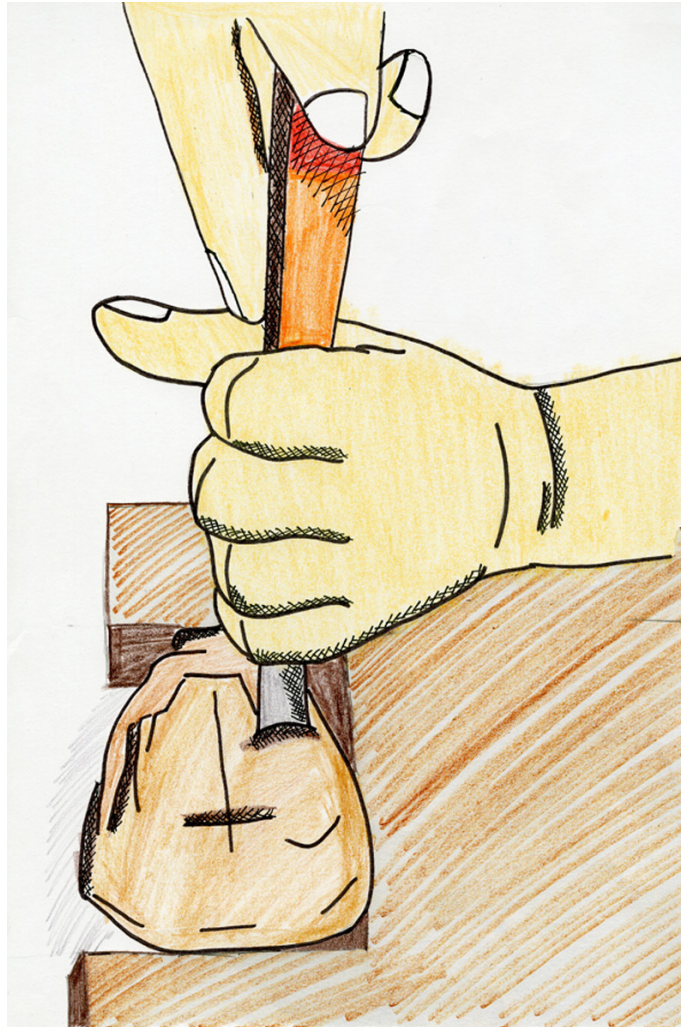

Various chisels are used to carve the puppet's face.



Required shape is obtained and the edges are smoothed using sandpaper.



Design Resource

## Yakshagana Puppets

String Puppets in India

by

Prof. Bibhudutta Baral, Divyadarshan C. S.,

Shruti K. and Smitha S.

NID Campus, Bengaluru

Source:

<http://www.dsource.in/resource/yakshagana-puppets/making-process>

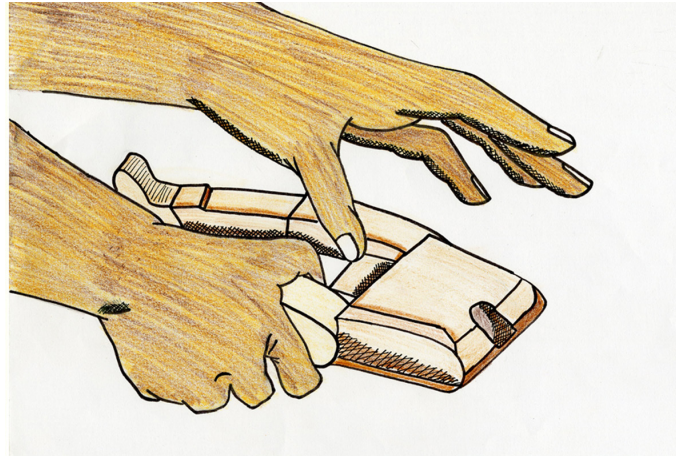

Parts of the puppets are made separately and fixed together.

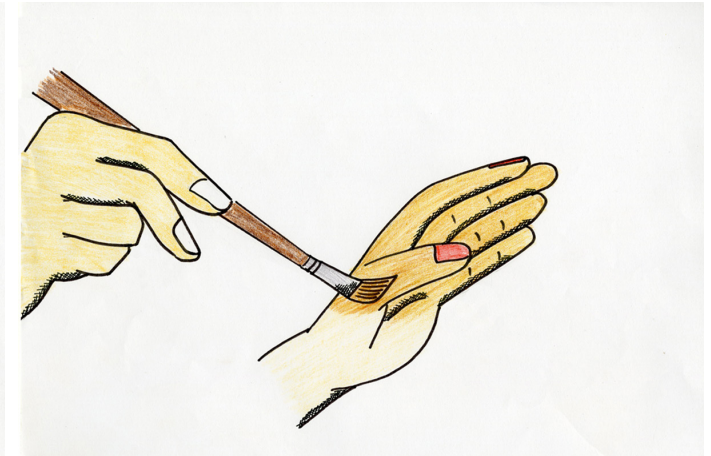

The parts like hands legs and face is painted with enamel paints.



Face is painted with yakshagana motifs.

1. Introduction
2. Tools and Raw Materials
3. **Making Process**
4. Products
5. Setting the Stage
6. Contact Details

Design Resource

## Yakshagana Puppets

String Puppets in India

by

Prof. Bibhudutta Baral, Divyadarshan C. S.,

Shruti K. and Smitha S.

NID Campus, Bengaluru

Source:

<http://www.dsource.in/resource/yakshagana-puppets/making-process>

1. Introduction
2. Tools and Raw Materials
3. **Making Process**
4. Products
5. Setting the Stage
6. Contact Details

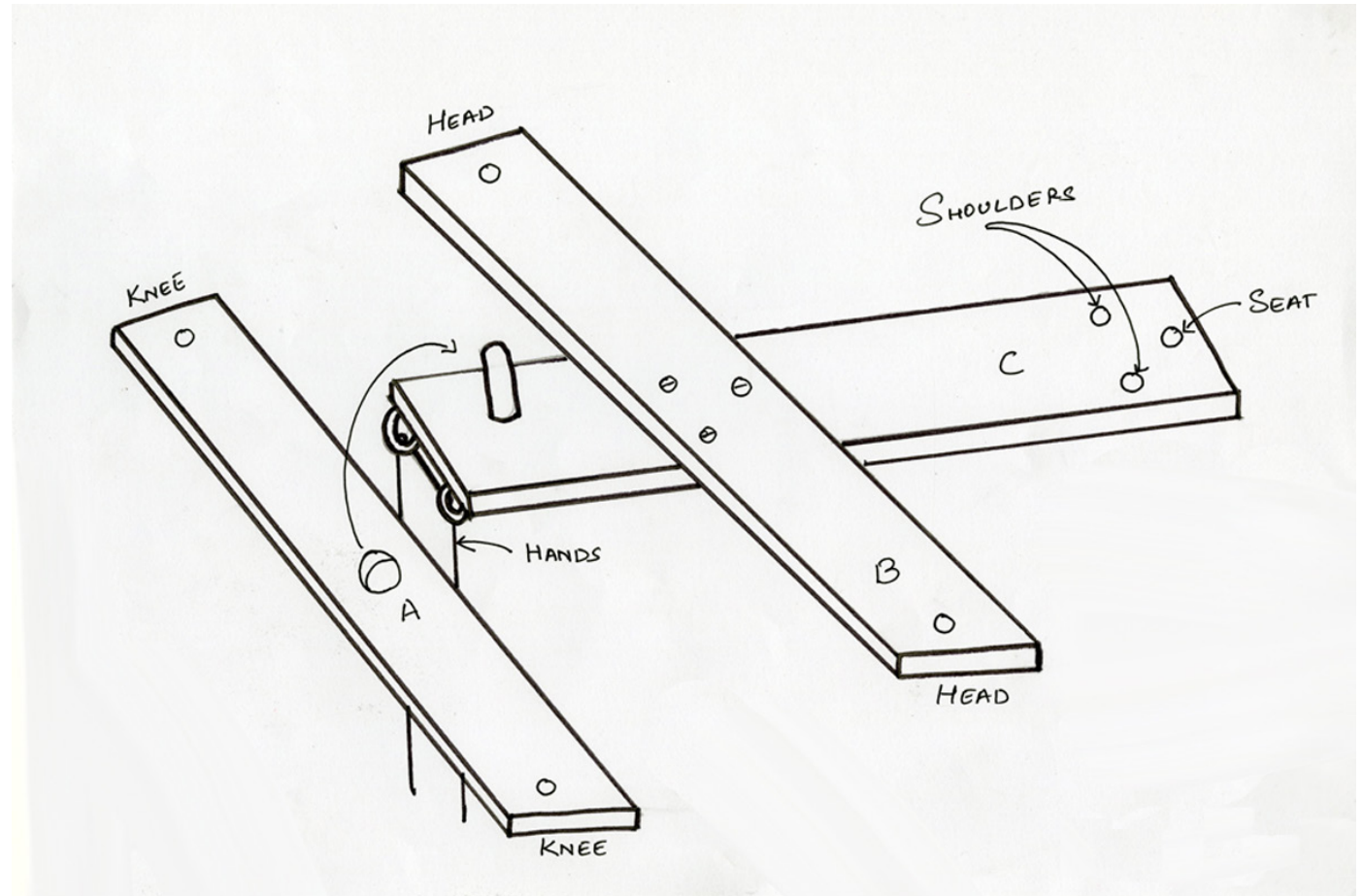

Airplane controller is used to control the puppets.



Design Resource

## Yakshagana Puppets

String Puppets in India

by

Prof. Bibhudutta Baral, Divyadarshan C. S.,

Shruti K. and Smitha S.

NID Campus, Bengaluru

Source:

<http://www.dsource.in/resource/yakshagana-puppets/making-process>

1. Introduction
2. Tools and Raw Materials
3. **Making Process**
4. Products
5. Setting the Stage
6. Contact Details



Puppets are dressed up in their respected costumes.

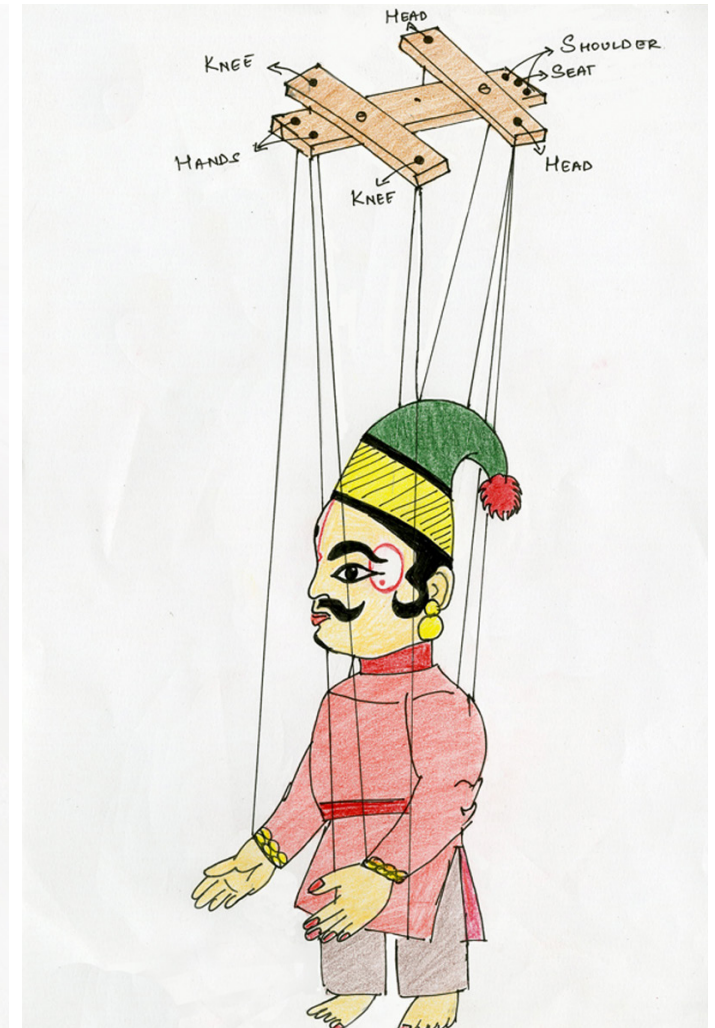

The strings tied to the puppet are tied to the wooden controller with which the puppet is controlled.

Design Resource

## Yakshagana Puppets

String Puppets in India  
by

Prof. Bibhudutta Baral, Divyadarshan C. S.,  
Shruti K. and Smitha S.  
NID Campus, Bengaluru

Source:

<http://www.dsource.in/resource/yakshagana-puppets/products>

1. Introduction
2. Tools and Raw Materials
3. Making Process
4. **Products**
5. Setting the Stage
6. Contact Details

## Products

Puppets vary in size from 2.5 – 4 feet tall and are very flexible in movement due to the use of fabric material in the making of these puppets. Different variations of puppet can be seen with yakshagana puppet and few of them are:

- **Stree Vesha** (female role) – Generally shown wearing a saree, which are traditionally worn by the women of Karnataka, colorful beads and light wood strips are used for the ornamentation on body as well as hair.
- **Purusha Vesha** (Male role resembling Arjuna) male character caring bow and arrow , wearing traditionally handloom cloth and headgear.
- **Krishna Vesha** male character resembling lord Krishna.
- **Bannada Vesha** (demon-villain) this character displays negative role, with large and thick eye brows, aggressive eyes and protruding canine teeth.
- **Kireeta Vesha** (king) male character wearing crown.
- **Hasya Vesha** (comedian or servant) male character with just handloom cloth and no jewelry or crown but with a conical shaped cap.
- **Muni Vesha** (sage) male puppet wearing orange color dress with long beard and whiskers, holding rudraksha mala and stick in other.



Varieties of puppet made according to the respective show's characters.



Design Resource

## Yakshagana Puppets

String Puppets in India

by

Prof. Bibhudutta Baral, Divyadarshan C. S.,

Shruti K. and Smitha S.

NID Campus, Bengaluru

Source:

<http://www.dsource.in/resource/yakshagana-puppets/products>

1. Introduction
2. Tools and Raw Materials
3. Making Process
4. **Products**
5. Setting the Stage
6. Contact Details



Puppet depicting a king of a respected play.



Ravana's puppet made for the Ramayana show.



Design Resource

## Yakshagana Puppets

String Puppets in India

by

Prof. Bibhudutta Baral, Divyadarshan C. S.,

Shruti K. and Smitha S.

NID Campus, Bengaluru

Source:

<http://www.dsource.in/resource/yakshagana-puppets/products>

1. Introduction
2. Tools and Raw Materials
3. Making Process
4. **Products**
5. Setting the Stage
6. Contact Details



Puppet depicting a demon.



Hanuman puppet made for Ramayana show.



Design Resource

## Yakshagana Puppets

String Puppets in India

by

Prof. Bibhudutta Baral, Divyadarshan C. S.,

Shruti K. and Smitha S.

NID Campus, Bengaluru

Source:

<http://www.dsource.in/resource/yakshagana-puppets/products>

1. Introduction
2. Tools and Raw Materials
3. Making Process
4. **Products**
5. Setting the Stage
6. Contact Details



Puppet depicting a comedian character in the respective show.



Puppet, which is used as a minister or a wise old king.



Design Resource

## Yakshagana Puppets

String Puppets in India

by

Prof. Bibhudutta Baral, Divyadarshan C. S.,

Shruti K. and Smitha S.

NID Campus, Bengaluru

Source:

<http://www.dsource.in/resource/yakshagana-puppets/products>

1. Introduction
2. Tools and Raw Materials
3. Making Process
4. **Products**
5. Setting the Stage
6. Contact Details



Puppet of Lord Shiva decorated with yakshagana motifs.



Lord Shiva's linga made as a puppet.



Design Resource

## Yakshagana Puppets

String Puppets in India

by

Prof. Bibhudutta Baral, Divyadarshan C. S.,

Shruti K. and Smitha S.

NID Campus, Bengaluru

Source:

<http://www.dsource.in/resource/yakshagana-puppets/products>

1. Introduction
2. Tools and Raw Materials
3. Making Process
4. **Products**
5. Setting the Stage
6. Contact Details



String puppet depicting a kind of demon.



Another type of king puppet.



Design Resource

## Yakshagana Puppets

String Puppets in India

by

Prof. Bibhudutta Baral, Divyadarshan C. S.,

Shruti K. and Smitha S.

NID Campus, Bengaluru

Source:

<http://www.dsource.in/resource/yakshagana-puppets/setting-stage-show>

## Setting the Stage



Two wooden tables are arranged on the stage.



The wooden tables are used to create a raised platform for the puppet show.



A metal frame is made to set on the stage for back-drop.



Back-drop is tied to the metal frame.

1. Introduction
2. Tools and Raw Materials
3. Making Process
4. Products
5. **Setting the Stage**
6. Contact Details



Design Resource

## Yakshagana Puppets

String Puppets in India

by

Prof. Bibhudutta Baral, Divyadarshan C. S.,

Shruti K. and Smitha S.

NID Campus, Bengaluru

Source:

<http://www.dsource.in/resource/yakshagana-puppets/setting-stage-show>

1. Introduction
2. Tools and Raw Materials
3. Making Process
4. Products
5. **Setting the Stage**
6. Contact Details



The remaining cloth on the top is tied to a string attached to the roof.

Design Resource

## Yakshagana Puppets

String Puppets in India

by

Prof. Bibhudutta Baral, Divyadarshan C. S.,

Shruti K. and Smitha S.

NID Campus, Bengaluru

Source:

<http://www.dsource.in/resource/yakshagana-puppets/setting-stage-show>

1. Introduction
2. Tools and Raw Materials
3. Making Process
4. Products
5. **Setting the Stage**
6. Contact Details



Another small frame is set behind the prepared stage.



Electric sockets are fixed on the stage for the electric bulbs.



Different color bulbs are fixed on the stage.



Design Resource

## Yakshagana Puppets

String Puppets in India

by

Prof. Bibhudutta Baral, Divyadarshan C. S.,

Shruti K. and Smitha S.

NID Campus, Bengaluru

Source:

<http://www.dsource.in/resource/yakshagana-puppets/setting-stage-show>

1. Introduction
2. Tools and Raw Materials
3. Making Process
4. Products
5. **Setting the Stage**
6. Contact Details



Stage is ready for the show.

Design Resource

## Yakshagana Puppets

String Puppets in India

by

Prof. Bibhudutta Baral, Divyadarshan C. S.,

Shruti K. and Smitha S.

NID Campus, Bengaluru

### Source:

[http://www.dsource.in/resource/yakshagana-puppets/  
contact-details](http://www.dsource.in/resource/yakshagana-puppets/contact-details)

## Contact Details

This documentation was done by Prof. Bibhudutta Baral, Divyadarshan C. S., Shruti K. and Smitha S. at **NID Campus, Bengaluru**.

You can get in touch with

- Prof. Bibhudutta Baral at [bibhudutta\[at\]nid.edu](mailto:bibhudutta[at]nid.edu)

You could write to the following address regarding suggestions and clarifications:

### Helpdesk Details:

Co-ordinator

Project e-kalpa

R & D Campus

National Institute of Design

#12 HMT Link Road, Off Tumkur Road

Bengaluru 560 022

India

Phone: +91 80 2357 9054

Fax: +91 80 23373086

Email: [dsource.in\[at\]gmail.com](mailto:dsource.in[at]gmail.com)

1. Introduction

2. Tools and Raw Materials

3. Making Process

4. Products

5. Setting the Stage

6. **Contact Details**