

UNDP project on Bamboo and Cane

Project Report on

Tools, Small Technologies and Finishes

by

Industrial
Design
Centre
IIT Bombay
September
2003



project **Tools, small Technologies and Finishes**

sponsored by **UNDP (United Nation Development Programme)**

through **Development Commissioner (Handicrafts)**

Ministry of textiles, Govt. of India

duration **2000-2003**

organisation **Industrial Design Centre**

Indian Institute of Technology Bombay, Mumbai-400 076

Acknowledgements

We are thankful to various Individuals and organisations who have helped us in various ways in carrying out this project.

We are grateful to following organisations and individuals belonging to these organisations: C B T C, IIT Guwahti, NHDC, Cane Concepts, NEHHDC, MHDC, DC (H), NIIFT. KFRI

we are also thankful to all the staff and students of IDC as well as staff of Dean (R&D)

We recieved help from many Industries like Kadinus, Lamicraft Entreprises, Precision Grinding ltd, Scan Tech, Wood Craft, Krishna ply, Saidulbhai and brothers, ... in making and manufacturing the tool kits and machines.

We are also thankful to many craft persons, designers and officials who gave their valuable suggestions and encouraged us from time to time.



Project Team

Team Leader **prof. A.G.Rao**

Associates	M.S.G.Rajan	Development Engineer, IDC
	Avinash Shinde	Designer
	Neeti Gupta	"
	Poomira Shenoy	"
	Khyati Nagar	"
	Nirav shah	"
	Ajay Tiple	"
	Sunder Mohan	"
	Dr.Krisna Lala	Consultant
	Chandan Halder	"
	Vinayak Deshmane	Engineer
	Mayur Rathde	"
	Niranjan Rudrapal	Craftperson
	Gangamma	"
	Krishna Suthar	"
	A.P.Jhon	project Assistant

IDC Students who assisted :

Shama Rasal, Yogesh S. Jahagirdar, Ajit S. Mulay, Sam
Thomas, Jitendra, Ajay Desai, Ritu Sonalika, Anushree,
Visakan, ,Barish, Sandesh, Kailash.

contract designers

Pradnyaa D. More

Ms. Seema Gondane

Contents

Acknowledgements

Project Team

1-17	Phase 1 : Tool Study and development
18-19	Get up workshop
20-30	Development of Tool Kit Tools
31	Tool kit manual
32-34	Product specific Tools
35-37	Small Machines
38	Manual for Small Machines
39	Finishes in Bamboo Craft
40	Colouring with Natural dyes
41	Manual for colouring bamboo
42-43	Preservatory treatments
44	Smoke Finish
45	Staining, lacquering
46-52	Phase 2: Productionising tool kits and small machines
53-54	Moulds, Jigs
55	Coil Technique
56-63	Cane Tools
64-69	MCFCs
70-74	MCFC at Diezhephe (Nagaland)
75-78	MCFC at Barapeta (Assam)
75-78	MCFC at Nalchar (Tripura)
83	Conclusion
84-91	Annexures giving list of participants in get up and other workshops

Phase 1

Phase 1 of the project started with identifying the problems through actual field studies and a thorough literature survey.

97 tools which can be used for bamboo were identified and made. A prototype of tool kit with many innovations evolved.

A set of 4 hand operated machines were developed.

Feed back workshops validated the tools and machines.

Several natural dye colouring methods as well as treatments were also developed and brought as printed manuals.



Cane split in Andaman using tool in Tripura style



Naga dhau being used in different ways

Tripura Dhau used in Assam



'Tool' Tradition In Bamboo Craft

Bamboo craft is age old and highly developed in North East. In a remote tribal home one finds an excellent piece of 'bamboo and cane' craft item. 'Khonoma' basket in Nagaland or equisit basket of Manipur are sophisticated in skills, but made in small numbers and often for a particular occasion or a person. Commercial cosiderations play a secondary role in these cases. Compared to this Tripura has a commercialised, village based mass production of baskets, mats etc. The well-known Tripura basket (also called Surya Mukhi) is made by all the persons in villages like Nalchar or Koimura.

But in spite of varied fashions in making, the attitude to 'tool' has remained same: One 'tool' for all purposes. In fact the Indian craftperson is so innovative that he or she is able to use the same tool 'Dhau' for all purposes starting from cutting of bamboo culm to splitting, strip making and finishing. This practice of using one tool is also common through out the country. However each area has its own 'Dhau' or 'Katti' which is distinct in its design and use. Thus we have in the North East, Naga Dhau, Assam Dhau, Manipuri Dhau, Tripura Dhau and Katti in other parts of the country.



Manipuri Dhau



katti used in Orissa



cane width sizing in Andaman

Variations in Manipuri Dhau

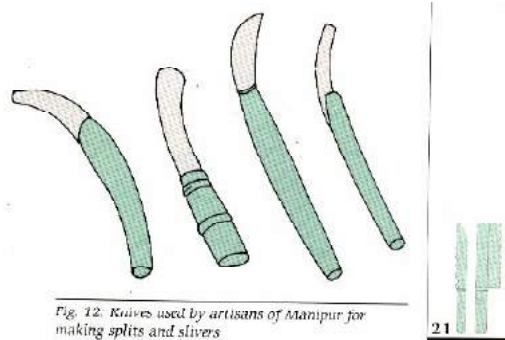

Fig. 12. Knives used by artisans of Manipur for making splits and slivers

21

Manipuri Dhau



Small variations in the design are common. Quite often each 'Dhau' is made to suit specific requirement of the particular craft person who has ordered it. Only in some places like in Nagaland and Assam one can see the 'dhaus' being sold in the village markets or by a particular toolmaker. Training at 'BCDI' (Bamboo & Cane Development Institute) at Agartala is based on use of 'Tripura Dhau'. Large number of craft person in Assam use Tripura dhau as they belong to Begalee community.

Craft persons also use few more tools though 'dhau' remains the major tool. A folding knife is often used for splitting and other purposes. This being handy craftsmen use it as a pocket knife. In Nagaland and Arunachal tribal males carry the 'dhau' all the time in the day traditionally. This has multiple functions like 'clearing the jungle', 'cutting a piece of bamboo', 'bunch of bananas' or 'for self-defence from a wild animal'.

It is difficult to document or collect a sample of tool as it is often used in a specific region and is not made for sale. The information trickled down slowly as the project proceeded. A bow saw made with a cane frame and standard hack saw blade was found in Arunachal Pradesh. A combination of two knives with height adjustment to size different widths of cane binding was being used in Andaman and Nicobar Islands.

Materials and processes for Making 'Dhaus'



Spring steel being heated for forging in a village of Meghalaya

The tools all over the country are made locally by the 'village smiths'. The material used is the 'spring steel' taken from old vehicles. The flat springs of Maruti Zipsy are quite popular. Spring steel is an ideal material as it can take the sharpness due to high carbon in it. The tool is forged into shape. The craft person shows a piece for shape. But generally an experienced 'smith' has all the relevant knowledge and generally knows what the shape of a local 'dhaus' should be. Thus 'he' is the designer-producer of the tools currently.

The 'dhaus' are tempered by quenching in water after forging to shape. At some places handles are fixed and given. Otherwise the craft person gets the handle fixed by a carpenter.



In Nagaland one tool maker in Dimapur makes the handles in bamboo, smokes them for insect protection and fixes with the blade. A cane binding is done on the handle.

A naga Dhaus being made in Dimapur



Bamboo Handles being smoked for naga dhaus



References

1. Salama.R.A, Dictionary of Tools, George Allen & Unwin Ltd, London, 1975
2. Gnanaharan. R and Mosteiro.A.P, Local Tools, Equipment and Technologies for Processing Rattan INBAR, , New Delhi, 1997.
3. Cort Louise Allison , Kenji Nakamura, A Basketmaker in Rural Japan, Smithsonian Institution, Washington D.C 1995
4. Training Manual, International Bamboo handicraft Training Course, Yiyang, China, October 1999.
5. Cusack Victor, Bamboo World, Kangaroo Press, Australia, 1999.

A literature search and survey was made to identify the tools used for bamboo all over the 'World'. It is difficult to get organized information at one stroke. It is even more difficult to get the 'samples of actual tools'. Earlier exposure of Prof. A.G. Rao to Indonesia, Thailand and China helped in getting wider information. A book published by INBAR, though did not contain drawings of the tools, was a good starting point.

Tools from sister trades like carpentry were studied to identify the tools usable for Bamboo. Eventually 97 tools usable for bamboo and cane were identified. Few readily available tools were procured. For rest of the tools sketches and drawings were made, often decoding from the photographs or poorly illustrated sketches.

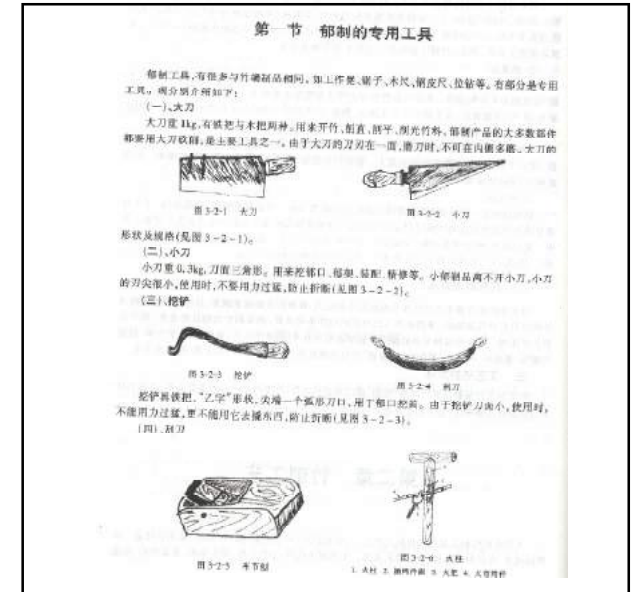

Tool pictures from chinese literature

From the drawings mock-up models in polystyrene were made to full size. These models were given to the local smith who forged the tools based on them. It was necessary to give the exact shape to the smith.

A process analysis was done to identify various tools required at each stage. An ergonomic study was also made to see the appropriateness of grips and postures.



plastic mock-up of chinese rounded scraping knife made and given to local smith

IDC student Ravi Koka working with Mumbai craftsman Patil in developing complex contours of a chair



Rudrapal binding the rim of the chair using a piercing tool



A skilled craft person from Tripura working on the project and Smt. Gangamma local craft person associated with the project gave important initial feedback.

Simultaneously few new products were designed and developed. The product development was used as an opportunity to innovate new tools. Earlier experience of a project 'Bamboo Link', sponsored by INBAR (International Network for Bamboo and Rattan) and few student design projects like developing stools and Chairs gave valuable insights into the requirement of new tools in Bamboo Craft.

Gangamma using a tool for inserting a strip





Out of these studies, an IDC Gauge, IDC multipurpose tool, Sand paper pad, Sand paper files emerged. IDC gauge evolved over a period to culminate into handy new item. IDC piercing tool was developed due to the problem faced while making holes in Newspaper baskets. Use of a drill bit ground to a needle shape helped in making holes without splitting of strips. IDC weaving tool took shape with a suggestion from a BCDI instructor during get-up workshop.

Thus 97 tools emerged as a tool bank. All these tools were classified according to operations and named. As such no standard names were available. All the tools along with pictures are listed in the next pages.





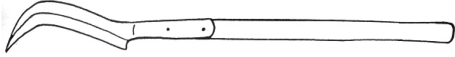
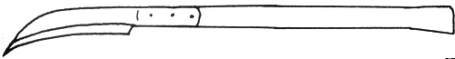

HARVESTING

SCRAPPING

LENGTH SIZING

	Crook Stick
	Slasher
	Bill Hook
	Axe
	Japanese Hatchet
	Thai Harvesting Blade







	Half-Round Scraper
	Pull Scraper
	Scrapping Knife
	Scrapping Knife
	Phillippine Knife `Parag`
	Short Plane
	Rounding Plane





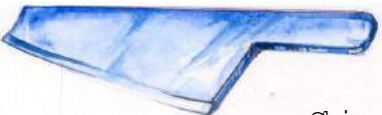

	Common Hacksaw
	Adjustable Hacksaw
	Chinese Hacksaw
	Chinese bowsaw
	L-Shaped saw
	Hand saw
	Coping saw

SPLITTING RADIAL

SPLITTING RADIAL

SPLITTING RADIAL

	Assam Dhau
	Manipur Dhau
	Tripura Dhau
	Machette
	Chinese Broad Knife
	Round Knife
	4 Blade Radial Splitter







	8 Blade Radial Splitter
	12 Blade Radial Splitter
	16 Blade Radial Splitter
	Splitting Cross
	Splitting Wedges
	Split Axe
	Lath maker's Split axe







	Chinese Machette
	Chinese Cleaving Knife
	Chinese Small Splitter





SPLITTING RADIAL

SHAVING & SIZING

SHAVING & SIZING

	Double Edged Cleaving Knife
	Tripura Dhau
	Chiesel Edge Cleaving Knife
	Cleaving knife
	Indian Foldable knife
	Indian Splitting Knife
	Balinese Splitting Knife





	Tripura Dhau
	Shaving Knife
	Small Shaving Knife
	Japanese Faceting Knife
	Chinese Shaving Angle
	Chinese Shaving Chisel
	Japanese Thinning Knife

	Shop Knife
DRILLING	
	Bow Hand Drill
	Hand Drill
	Powered Hand Drill



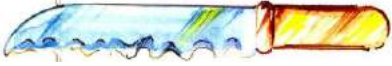

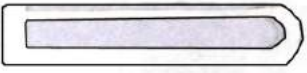

TRIMMING

	Common scissors
	Curved jaw shears
	Pruning scissors
	Sheet trimmer
	Strip cutter
	Goose wing knife

SHAPING

	Profile knife
	Profile Blade
	Stick Rounding Plate
	Stick Rounding Tool
	Stick Rounding Tin
	Balinese Chisel

SHAPING





	Balinese Furniture Knife
	Bevel Edged Chisel
	Scooping Chisel
MEASURING TOOLS	
	IDC Gauge
	Steel rule
	Folding scale





MEASURING TOOLS

REMOVAL OF KNOTS

WIDTH SIZING

	Tailor`s Tape
	Steel Tape
	Inside Callipers
	Outside Callipers
	Divider
	Compass

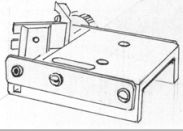
	Scooping Tools
	Scooping Chisel
	Scooping Hook
	Scooping Knife
UNIFORM THICKNESS	
	Uniform thickness tool
	Basket shaver

	Sizing knives
	Sizing blades
	Uniform width tool
	IDC Width Sizer
FINISHING	
	Files
	Needle File

Feed back on Tool Concepts :Delhi workshop

Listing of all tools and categorising them based on functions became a good starting point for feedback. Along with the general tools concepts for two types of tool kits were also conceived: a general tool kit with 18 tools and an advanced tool kit with more than 30 tools.

These ideas and information were presented by Prof. Rao in a workshop organized by NIIFT at Delhi for designers and craftpersons from North East. The workshop was attended by representatives of the export promotion Council as well as exporters of bamboo cane products from Delhi. A separate presentation was also made to Mr. Vinod Malhotra, adviser to UNDP programme as well as to the resident head of UNDP programme at Delhi who visited the workshop.

IDC designer Avinash Shinde and skilled craft person Niranjan Rudrapaul participated in the 10 day workshop to interact further with craft persons from Arunachal Pradesh, Tripura, etc. and Delhi designers and to get an initial feedback as well as requirements identified from either side. New Designs demanded new tools

After the Delhi workshop, a full set of all the tools listed were made by working with a local Smith. These were tried out to get a feel of them. The photographs of the various tools kept as board tools at Bambu Studio of IDC can be seen in the next pages.

With the feedback on the concepts and further analysis of the requirements, one tool kit was finalised out of the two. A prototype of the tool kit was made. Making of all the 97 tools and a tool kit prepared a ground to call for a feedback workshop. CBTC (Cane and Bamboo Technology Development Centre) headed by Mr. Kamesh Salam which was taking shape took the initiative to organise a workshop at Guwahati.

Tool Board Tools

All the tools were actually made for testing and using. One set of tools to CBTC and one set to BODI were supplied as a tool library for Training



BOARD 1

1. L- SHAPE SAW
2. COMMON HACK SAW
3. HUNTER'S SAW
4. ADJUSTABLE SAW
5. CHINESE HACKSAW
6. COPING SAW
7. CHINESE BOW SAW
8. INDIAN CANE FRAMESAW
9. HAND SAW

BOARD2

10. ROUND KNIFE
11. CHINESE BOARD KNIFE
12. CHINESE SMALL SPLITTER
13. SPLITTING CROSS
- 14.1 ASSAM DHAU
- 14.2 MANIPURA DHAU
15. TRIPURA DHAU
16. CHINESE MACHETE
17. MACHETE
- 18 .SPLITTING WEDGE
19. CHINESE CLEAVING KNIFE
- 20 .SPLIT AXE
- 21 .LATHMAKER'S SPLIT AXE

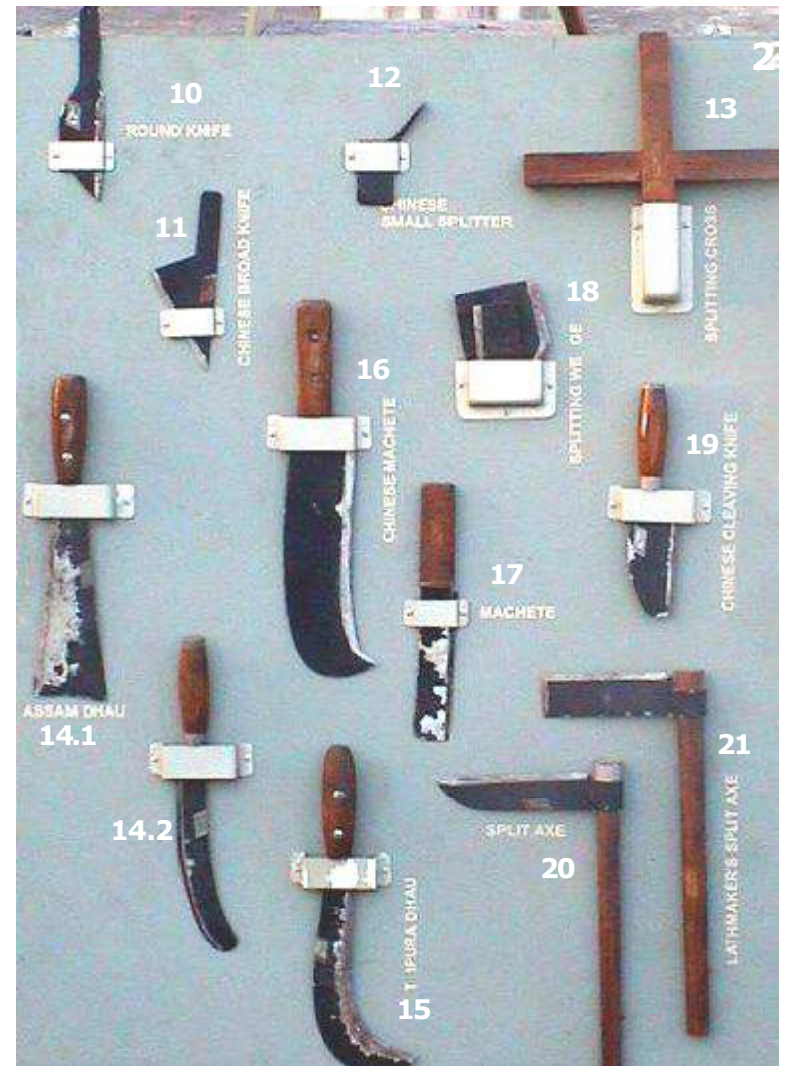

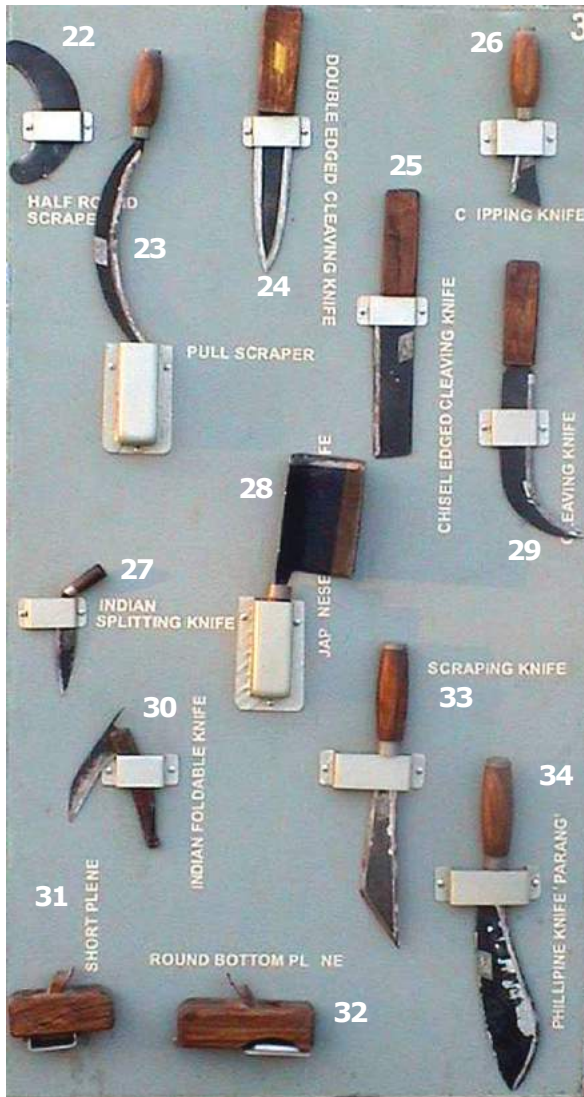

BOARD 3

- 22 HALF ROUND SCRAPER
23. PULL SCRAPER
24. DOUBLE EDGED CLEAVING KNIFE
25. CHISEL EDGED CLEAVING KNIFE
26. CLIPPING KNIFE
27. INDIAN SPLITTING KNIFE
28. JAPANESE SCRAPING KNIFE
29. CLEAVING KNIFE
30. INDIAN FOLDABLE KNIFE
31. SHORT PLANE
32. ROUND BOTTOM PLANE
33. SCRAPING KNIFE
34. PHILIPPINE KNIFE 'PARANG'

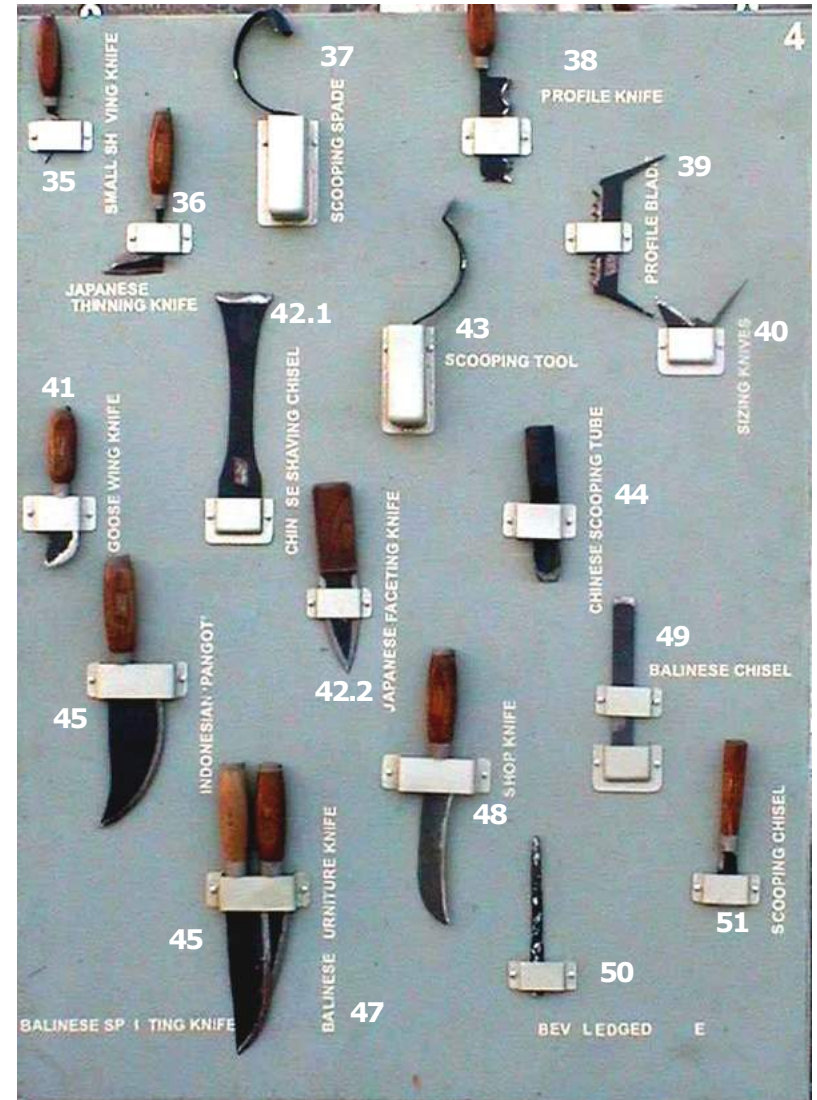

BOARD 4

35. SMALL SHAVING KNIFE
36. JAPANESE THINNING KNIFE
37. SCOPING SPADE
38. PROFILE KNIFE
39. PROFILE BLADE
40. SIZING KNIVES
41. GOOSE WING KNIFE
- 42.1 CHINESE SHAVING CHISEL
- 42.2 JAPANESE FACETING KNIFE
43. SCOPING TOOL
44. CHINESE SCOPING TUBE
45. INDONESIAN 'PANGOT'
46. BALINESE SPLITTING KNIFE
47. BALINESE FURNITURE KNIFE
48. SHOP KNIFE
49. BALINESE CHISEL
50. BEVELEDGE KNIFE
51. SCOPING CHISEL

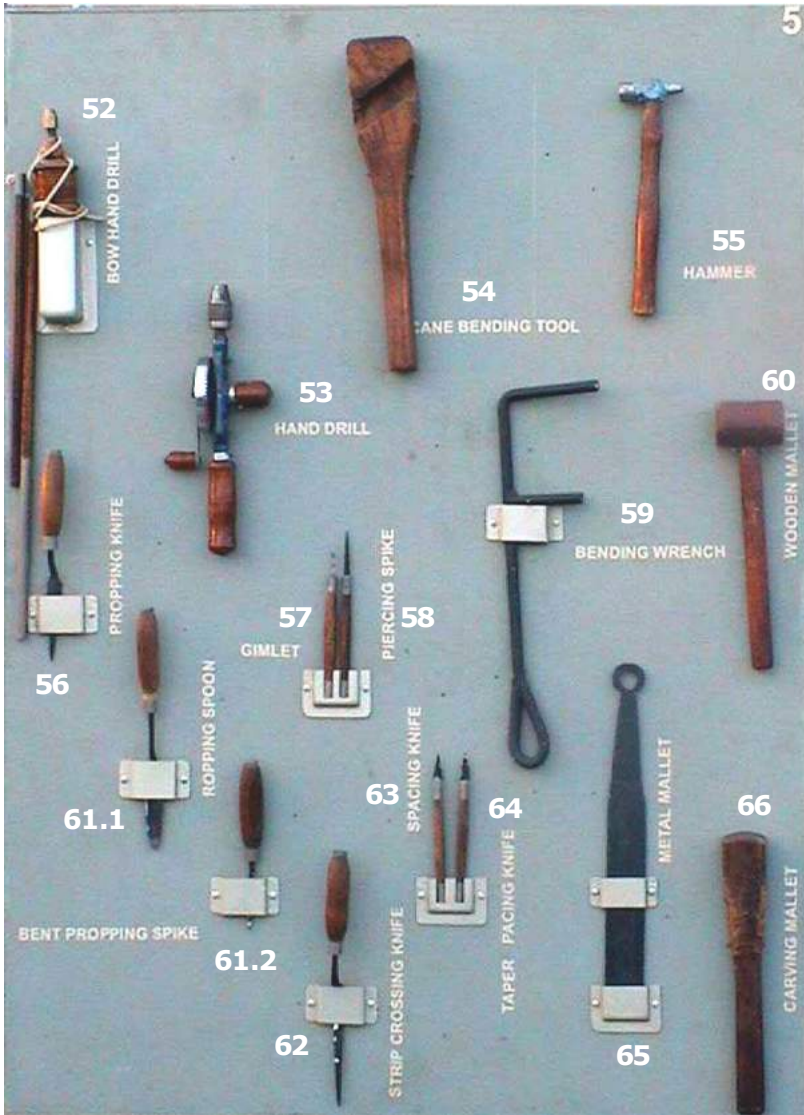

- BOARD 5
- 52. BOW HAND DRILL
 - 53. HAND DRILL
 - 54. CANE BENDING TOOL
 - 55. HAMMER
 - 56. DROPPING KNIFE
 - 57. GIMLET
 - 58. PIERCING SPIKE
 - 59. BENDING WRENCH
 - 60. WOODEN MALLET
 - 61.1 BENT DROPPING SPIKE
 - 61.2 PROPPING SPOON
 - 62. STRIP CROSSING KNIFE
 - 63. SPACING KNIFE
 - 64. TAPER SPACING KNIFE]
 - 65. METAL MALLET
 - 66. CARVING MALLET

- BOARD 6
- 67. IDC GAUGE
 - 68. STEEL RULE
 - 69. COMMON SCISSORS
 - 70. BRUSHES
 - 71. OUTSIDE CALIPERS
 - 72. INSIDE CALIPERS
 - 73. FOLDING SCALE
 - 74. TAILORS TAPE
 - 75. STEEL TAPE
 - 76. CURVED JAW SHEARS
 - 77. NEEDLE FILES
 - 78. DIVIDER COMPASS

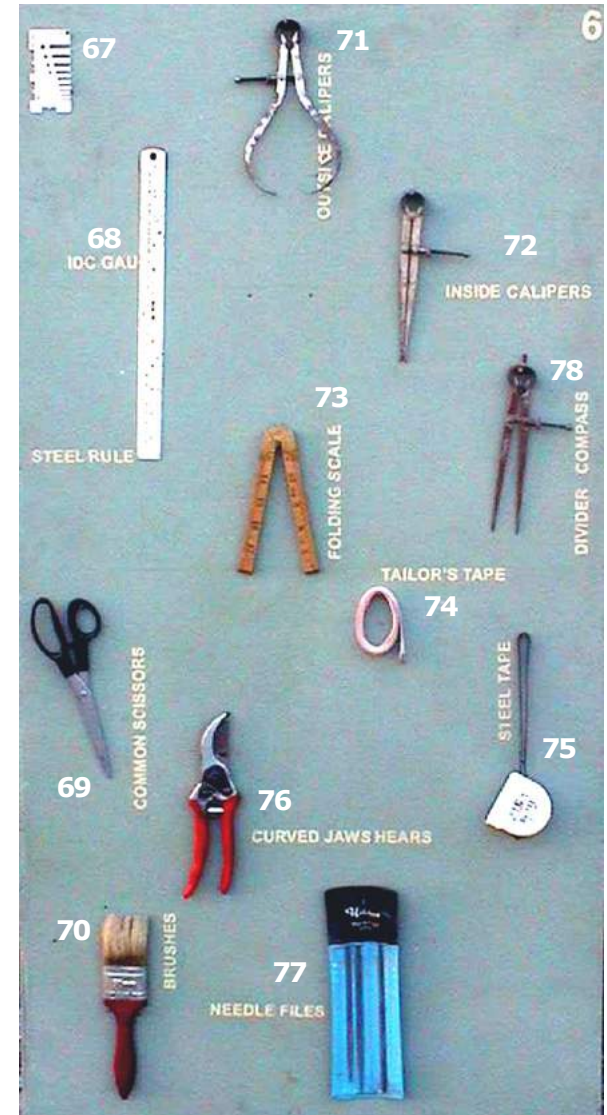



Participants at get up workshop with the new tools in the background

Get-up Workshop

The workshop called 'Get-up' covered various sessions on use of tool kits, small machines developed by IDC, on Costing, Production planning, new designs and product specific tools, use of moulds etc. Participants also visited IIT-Guwahati to see the facilities of Design Department for Bamboo Craft.

30 craft persons, entrepreneurs and Govt. officials from all over North East participated in the workshop. Day to day time table and the list of persons who attended the workshop are given in the Annexure1



Mr. Pariyat, M.D of MHDC discussing with his group of craftpersons

A systematic feedback was collected by giving specially prepared forms to know the usability of each tool out of the '97' tools as well as in the proposed tool kit. Many demands came to include more tools in the tool kit. Foldable pruning Saw was in great demand as it gives clean cut with green bamboo.

Mr. Malhotra, Adviser to the UNDP programme, a representative of DST, Dr. Ramanuja Rao of INBAR, Kamesh Salam of CBIC, Prof. Nakkami of IIT Guwahati, Mr. Hatzau, regional director, D.C (H) were also present in the feedback session to validate the tools.

Two tool kits were given to C.B.T.C. to collect further feedback from workshops to be conducted at different places.

Prof. A.G. Rao made a presentation at a workshop in Nagaland on tools and moulds, conducted by C.B.T.C. team.

Thus a complete tool kit with '33' items along with well-illustrated Manual emerged by the end of the 1st phase. The final prototype was presented at the Guwahati review meeting held by D.C. (H) and UNDP at C.B.T.C.



Proposed tool kit components

Mr. Vinod Malhotra with Dr. Ramanuja Rao behind



Prof. Nakkami along with Montu Das and other participants



Tools based on process

The Tool kit-Tools were developed, based on the processes involved in converting raw bamboo into end products. Various processes from cutting raw bamboo to finishing and fine weaving were studied sequentially which helped in categorizing and finding the new tools required. All the tool kit-tools are grouped based on the processes.

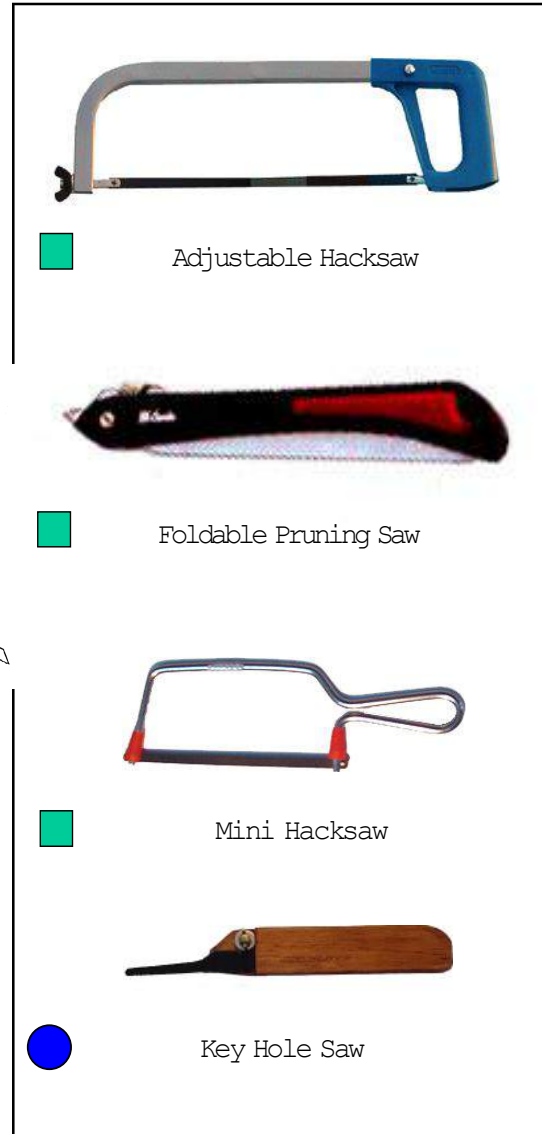

Sawing Tools

Cutting bamboo to different sizes would demand sawing operation. But traditionally bamboo craft persons seldom use saws of any kind. Cross cutting of bamboo is done with 'Dhau' As most of the work is done with 'green bamboo' chopping with 'Dhau' is adequate for making traditional objects. Hack Saw is a common engineering tool which can be used by bamboo craft persons. Hack saw is ideal for cutting 'dry bamboo' as well as hard varieties of bamboo in green stage. Hack saw though slow in operation gives a clean cut. The hack saw used in the tool kit is made by Mac Forge' a Mumbai based company exporting Hack saws.

Pruning Saw given in the tool kit is very effective for cutting Hallow green bamboo. It gives clean straight cuts. Pruning Saws are not made in India. The one provided in the tool kit is imported from other countries. The pruning saw is foldable and easy to carry. It can be very useful to cut bamboo from grove.

Mini hack saw is easily available. Fine cuts can be made easily with Mini hack saw. It is very useful for making fine precise parts in Bamboo .

Key hole saw is adopted from the existing saws. Key hole saw can be very useful to cut blind holes in bamboo from one end for furniture.

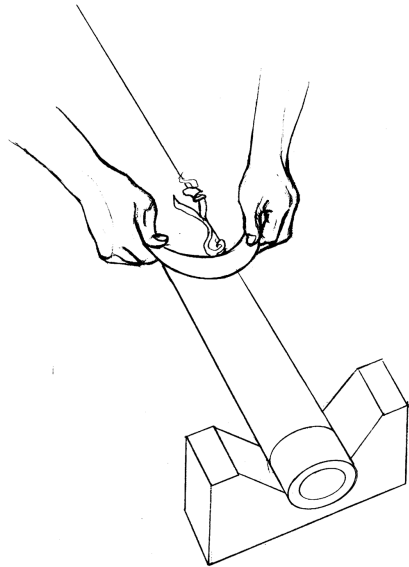

Scrapping Tools

Scrapping of outer skin of bamboo is common in N.E. Normally 'Dhau' is used for this purpose. Since 'Dhau' is not specifically designed for scrapping, the operation becomes strenuous, time- consuming and inefficient. Half round scraper is a Chinese tool, which is effective for this purpose.

Getting the correct half round shape is difficult and timeconsuming by traditional methods of 'Smithy' . Alternatives were looked at. Shaping by laser cutting became attractive as it gives not only correct shape but is inexpensive for small production numbers .

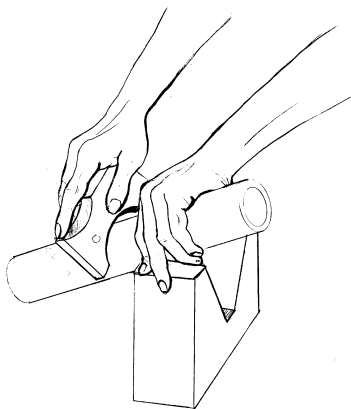

The scraper in the tool kit is laser cut and the sharp edge is ground using a special jig. It is made of spring steel and hardened.

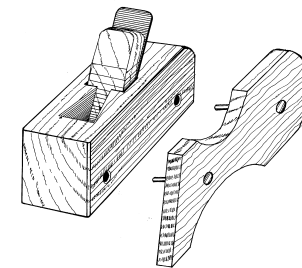

Jig plane is an IDC innovation. The jig attachment to a small wooden plane acts as a guide to remove 'knots' on the outer side of bamboo. Traditionally the operation is done with 'Dhau', which is difficult and inefficient. The jig attachment can be placed on either side of the plane to give guidance for 2 sizes of bamboo. Craft persons can make their own jig attachment to suit the size of bamboo they are using, if needed.

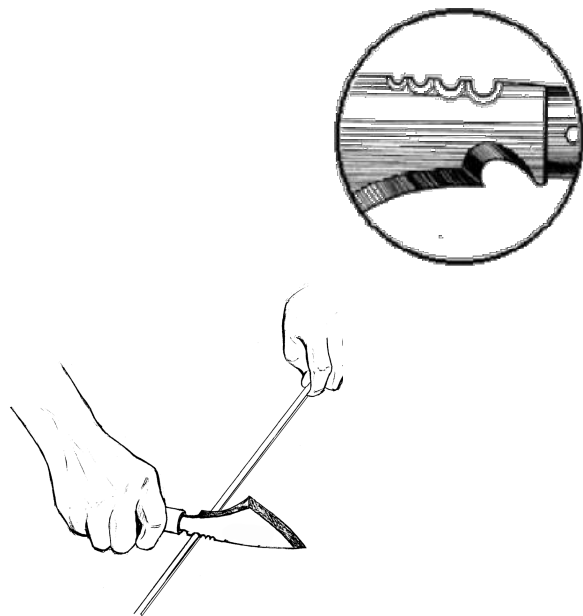



-  Readily available
-  Adopted and modified
-  Newly innovated



Strip Making Tools

There are five tools in the tool kit for strip making. Machette has a plain wide blade and can be used for splitting Bamboo into half. It can replace Dhau in most of the operations. A rubber strip inserted inside the wooden handle gives cushioning. This reduces the impact on the hands while cutting bamboo.

IDC multi purpose knife has multiple functions. It can be used for scraping, strip making as well as for making round sticks. It can also be used for inserting strips while weaving baskets.

IDC fine splitting knife is ideal for making fine splits with its wide blade. Craft persons often like to 'grind' the sharp edge further to give a uniform slope spread over the blade as per their requirement.

IDC width sizer is a handy tool with '3' fixed given width sizes. It can be adjusted to different widths by moving the blade up and down.

Pruning Scissors is a bought out item, normally used for gardening. It is very useful for cutting bamboo strips without causing splits, due to the curvature in the blades.

Measuring tools

In bamboo craft traditionally measuring has been by the 'feel' craft persons develops. Tailors' tape is some times used for length and circumference measuring. Thickness of strips is maintained only by 'feel'. Experienced craft persons are able to do 'even' strips without measuring.

New products, which have to fit other parts demand measuring.



Measuring tools quite often become the means for introducing 'literacy' to bamboo craft persons. The learning of numbers become more meaningful for 'adult craft persons' who are skeptic of adult education programmes.

IDC gauge was developed with the specific needs of bamboo craft person in mind. One can check even 0.25 mm thickness using IDC gauge, which is made by 'laser cutting' to give accurate measurements. 0.5 mm and 1, 2, 3, 4, 5mm are common measurements required by bamboo weavers. IDC gauge caters to these needs. It also helps in adjusting small machines like 'width sizer' to the exact width.

Inside Caliperse can be used to measure inside dimensions of small basket rims .

Outside Caliperse helps in taking outside dimensions. These measurements become important in making of items like furniture, baskets with tight fit lids, lamps etc.

A steel rule of 12" length is also provided in the tool kit, as the tailors' tape is not accurate and inconvenient to use for certain type of measurements.

Measuring tape also called Tailor's tape is useful in measuring circumference of the baskets for making rims. It is handy to measure length of bamboo etc. .

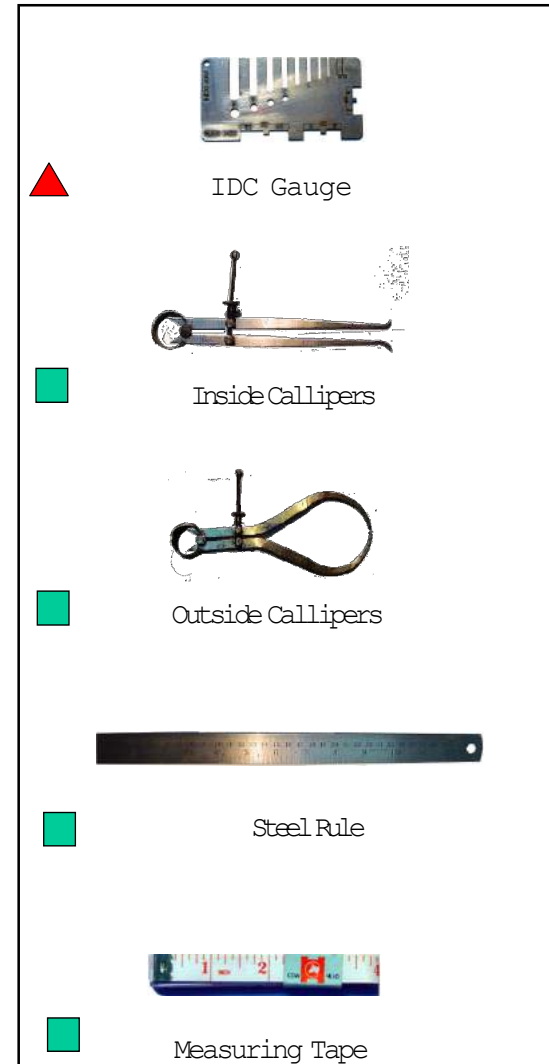

Marking tools

Marking needs for a bamboo craftperson are few. Often marking is done using a strip of bamboo as a measure to get same lengths. Readily available 'bangle' or any plate is used to mark a circle. A set of templates containing different sizes of circles and ellipses are provided in the tool kit. A standard template used by school children is also given in the tool kit. Templates are handy to mark exact geometrical shapes. Templates can be used for marking exact holes in furniture making and in marking mats to the required shape for trays and other products. The compass can be used to mark circles of desired radius.

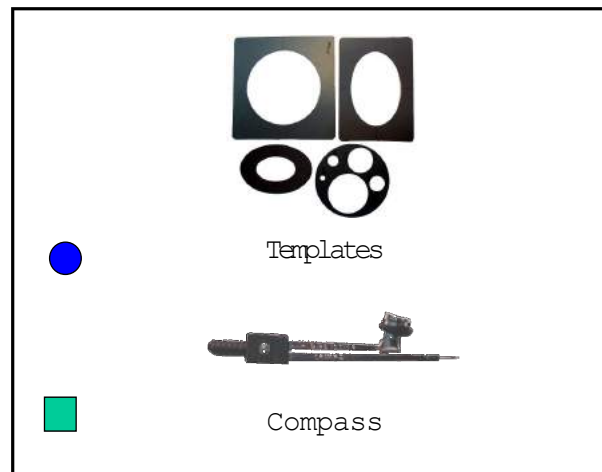
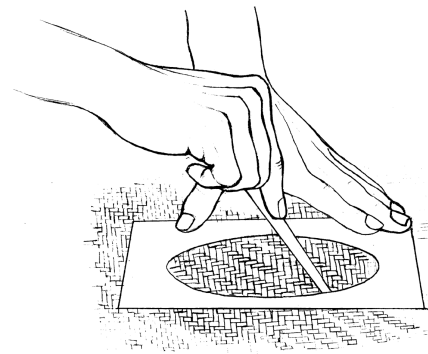

- Readily available
- Adopted and modified
- ▲ Newly innovated

Weaving tools

No special tools are used currently in Bamboo and cane weaving. But special tools can aid weaving process. IDC weaving tool is like a shoemakers stitching needle. The suggestion for the tool came from a B.C.D.I. instructor Shri Makan Das during 'get-up' workshop. The IDC weaving tool helps in fine weaves, which are done in Tripura for lamp-shades.

Propping knife is a Chinese tool mainly used for inserting strips in to weave or legs into a basket. The shallow groove creates room to insert a new strip once the tool is pushed into the weave with its sharper tip.

Work-board is a new concept introduced to facilitate weaving as well as mounting moulds. Often weavers in the villages are sitting on the ground and weaving. When fine mats are to be woven with precision a need for plain surface arises. The board also has circles and 8 axes to guide the weaving.

The board can accommodate a pin in the centre. A specially made metal pin, which can act as a fulcrum for the moulds can be inserted at the centre of board. The circular or elliptical moulds are rotated on the board for making rims for the baskets. The central pin is also used to make plates etc with coil technique. The circular guides can help in weaving Tripura's tangential weave (surya mukhi) baskets. The horizontal and vertical axes can help in checking the right angles of a mat while weaving.

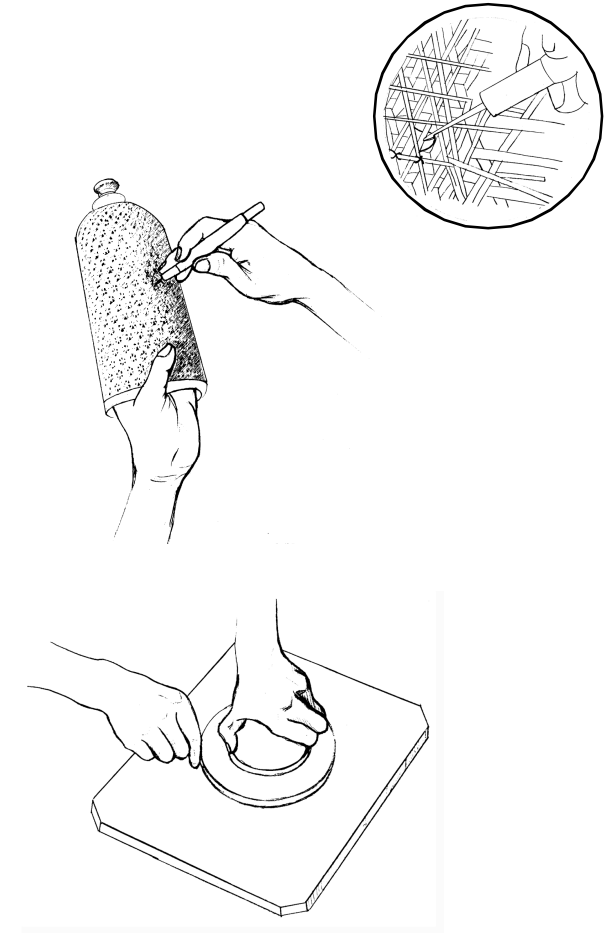
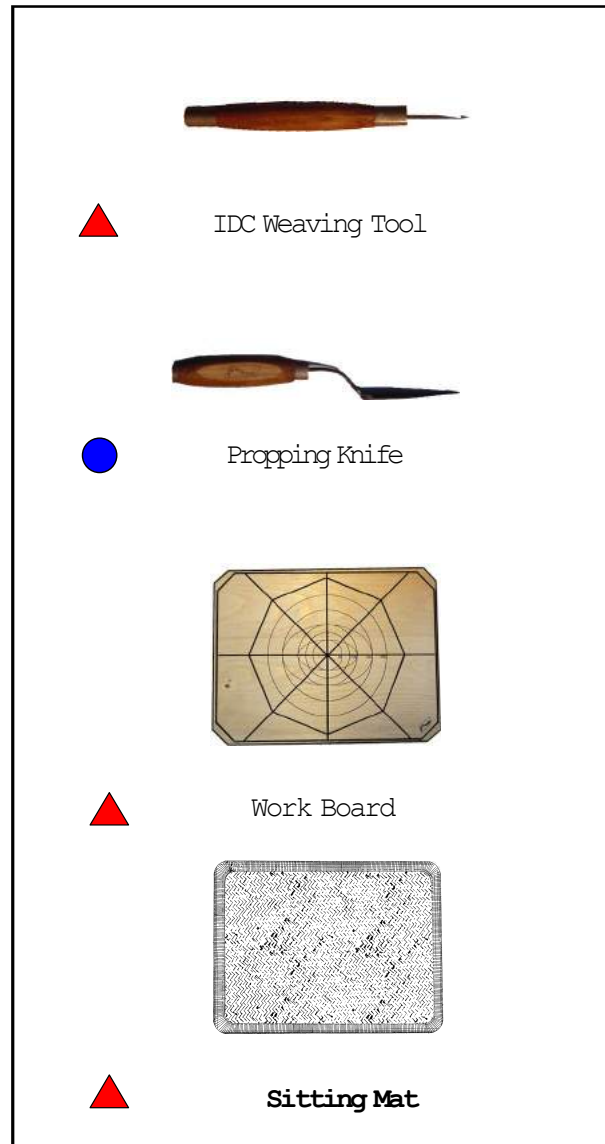

A sitting mat added in the tool kit is also based on a suggestion made in the get-up workshop by a craft person. It is handy for craft persons who sit on the ground traditionally.

Binding Tools

Bamboo products are bound by cane, a nail or adhesive like fevicol. Four tools were identified in this binding or assembling process.

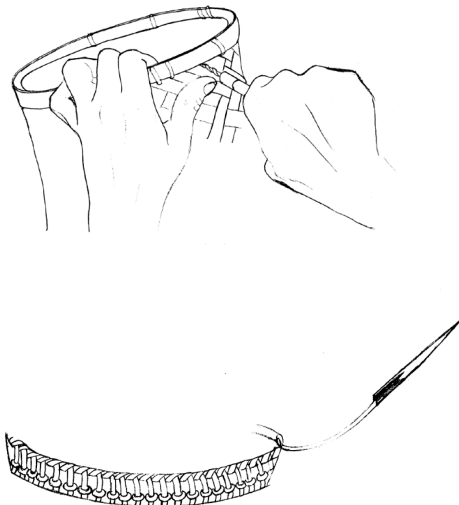

A hand drill is a common tool for making holes.

But Bamboo craft person seldom uses it as it is not required in making traditional items.

The manually operated drill in the kit, given with a special 'tool bit', can be used to make holes in thin strips of bamboo without splitting them.

Hand drill can also be used to cut bigger holes in bamboo for furniture etc.

A small hammer given in the tool kit helps to fix bamboo nails with precision.

IDC piercing tool is specially made to pierce holes without splitting the strips in baskets where the rims are bound by 'cane'. The piercing tool is rotated as its sharp tip pierces into the strip. The standard drill bit ground in to a 'spike' shape facilitates piercing of holes.

Rim binding needle is another IDC innovation.

A special slot at one end of the needle is provided.

Tip of the binding cane can be inserted in to this slot from one end. This facilitates easy binding of the 'rims' of baskets as this tool can be used like a suing needle.

A small box is provided to store the rim binding needle, drill bits, tape, etc.

Sharpening Tools

Two emery sticks of special shape are given in the tool kit to sharpen the tools. General sharpening is usually done with a standard emery stone block.

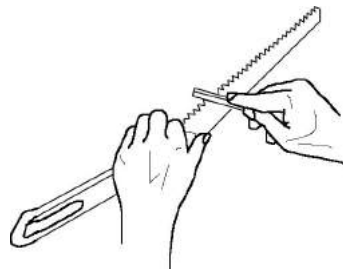

The triangular emery stick is specially made to sharpen the blades of pruning saw. The angle of the stone is made to fit gaps in the pruning saw thereby making precise sharpening of the saw possible.

The half round emery stick is needed to sharpen the 'round profiles in Half round scrapper and IDC multipurpose knife.

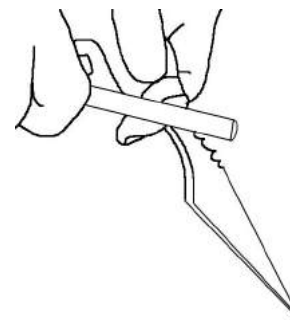

- Readily available
- Adopted and modified
- ▲ Newly innovated

Finishing Tools

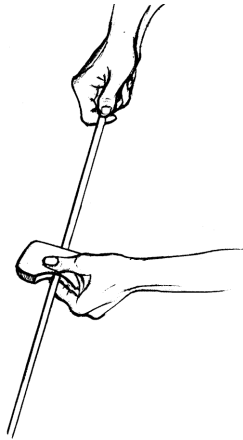

Bamboo Craft persons use only 'knife' or 'chau' for finishing as the work is done always with green bamboo. But dry bamboo finishing is important in products. A sandpaper pad facilitates easy finishing of strips. Thin strips of bamboo are pulled after folding the sand paper pad with strip in between!

The sand paper file is useful to finish joints etc.

Two needle files of triangular and half round shapes are also given in tool kit. They are useful for finishing fine slots in bamboo. Sharpening of tools like pruning saw and half round scraper can also be done with the needle files.

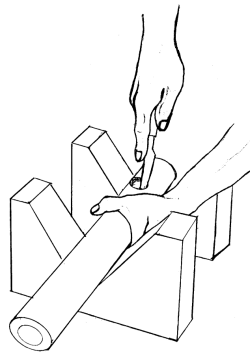

A 'Chisel edged rasp file' is an IDC innovation. Long rasp file is cut to short length and the edge made to wedge shape to act as a chisel. Rasp chisel File can be used as chisel. Its main use is to make finished holes on one side of round bamboo for furniture joints.

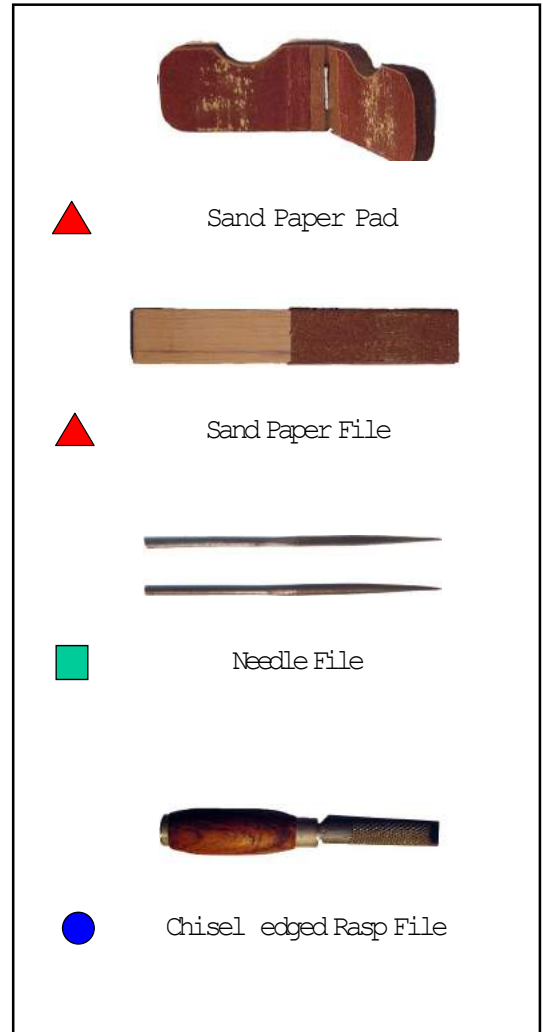

Sand Paper Pad



Sand Paper File



Needle File



Chisel edged Rasp File



Tool kit Bag

The tool kit bag is specially made to give an identity to the 'bamboo craft tools'. The specially dyed 'Seethal patti' on the top of the bag gives sophisticated look. The bag is reinforced with a thick PVA sheet to strengthen the bag. Inside components are powder coated for better looks and to prevent rusting. All the components like 'legs' of the bag are carefully selected for better quality and aesthetics. Inside the bag specially designed folder holds the tools. The graphics makes it easy to locate each tool in its special pouch.

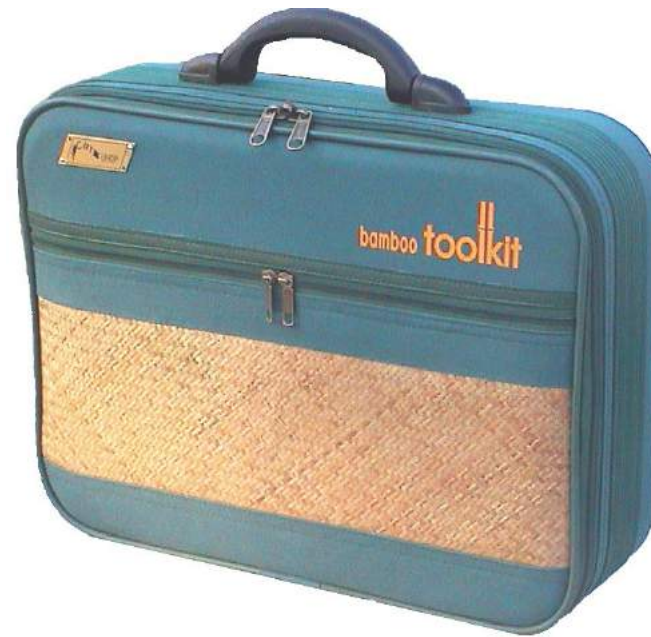

IDC Multipurpose Knife

The IDC multipurpose knife is designed to have blades on all edges for multiple functions. Its round handle fits in the palm providing good grip.

It is used for

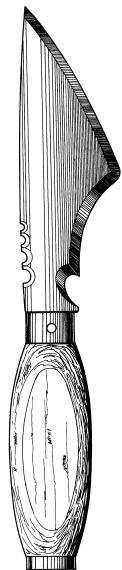

220x210mm

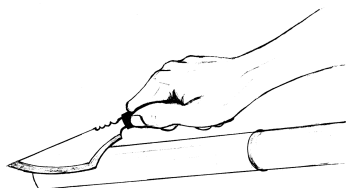

Scrapping bamboo

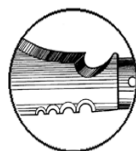

Rounding edges of strips

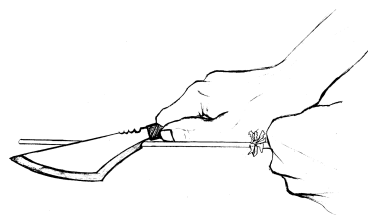

Making round sticks

Tool Kit Manual Design

A manual for the tool-kit became necessary, as 2/3rd of the tools were new to bamboo craft person. Since many craft persons may be illiterate, visually elucidating the functions become important. Initial version has been brought out in English, as it was most acceptable in North East.

A systematic methodology was adopted to choose the illustrations. Initially a 'video' in a digital format was taken for each tool while being used in different ways. Then '3' to '4' salient frames were chosen which illustrate the 'salient' use of each tool. These photographs were later converted into line drawings using computer as well as free hand sketching. Thus not only the aesthetic quality of illustration is achieved but also the correctness of postures were ensured.

For Clarity of details each of the tool is rendered in ink with a high professional standard. Thus the manual explains the tool, its material, maintenance in addition to how it is to be used. The cover page with an attractive illustration is laminated to ensure long usage in the hands of craft persons.

The Tool kit Manual has 40 pages with illustrations for each tool as seen in the sample page for IDC multipurpose knife.

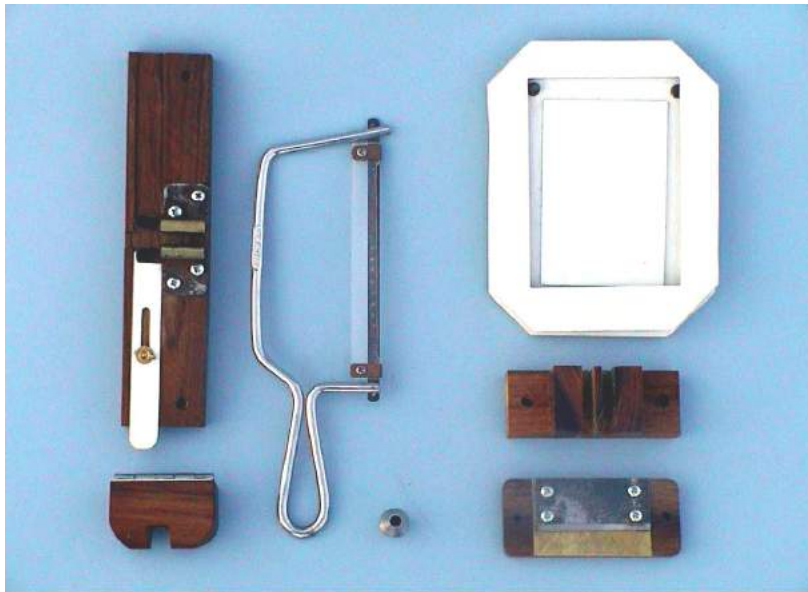

product specific tools for the note pad

Product Specific Tools

Bamboo Craft has a long tradition especially in the North East. Craft persons are quite skilled to make a particular product, which they know how to make with the existing tools. New tools do not 'seem' to be significant in this context. New product designs and innovations are necessary for the survival of the craft. Earnings in new and novel products are higher making 'repositioning of bamboo craft' possible. Quite often the general tools in the tool kit are not sufficient to make 'new products'. Thus the concept of 'product specific tools' took shape at the Barbu Studio of IDC.

A set of product specific tools were innovated to make 'frame based products'.

A small note pad, a menu card-holder, a diary cover and a file-folder were designed at IDC.

note pad

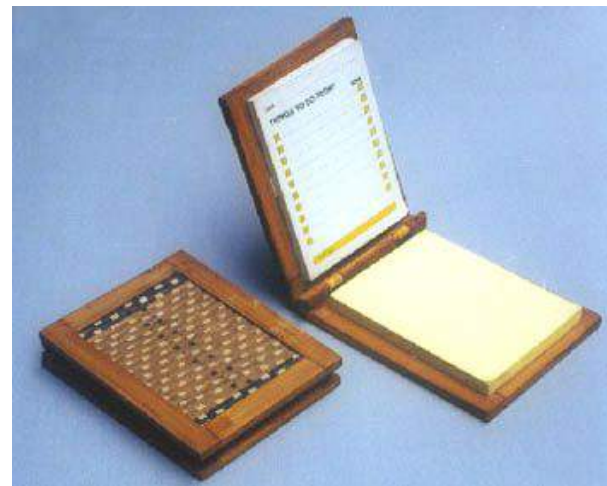

A frame based product 'note pad' needs 18 tools. In this '9' are general tool in the tool kit rest of '9' are specific to the product. Product specific tools include moulds, jigs and special tools developed for the product.

General tools

1. Matchette or Dhau
2. Chisel edged rasp file
3. Mini Hack saw
4. Width sizer
5. Thickness sizer
6. IDG gauge
7. Hand drill
8. IDC piercing tool
9. Sand paper Block

Product Specific tools

10. Sheet trimmer
11. Half cut saw
12. Step cutting Jig
13. Step making tool
14. Frame Mould
15. Frame ejector
16. Round stick making die
17. Slot cutting jig
18. Slot making tool

General tools are part of the toolkit. Product specific tools are described further.

10. Sheet trimmer:

Photo sheet trimmers are available in the market. The trimmer is adopted with a 'jig attachment' to give '2' exact lengths of strips. Thus the pieces for 'length' and 'breadth' can be cut using the sheet trimmer effectively.



11. Half Out Saw: To make the frame joint each strip is to be cut to a depth of 1mm out of 2mm thick strip. A special tool is designed to facilitate this. An attachment is fixed on mini hacksaw which stops the cutting once it reaches 1mm depth. With this 1mm depth out of 2mm thick strip can be easily cut.

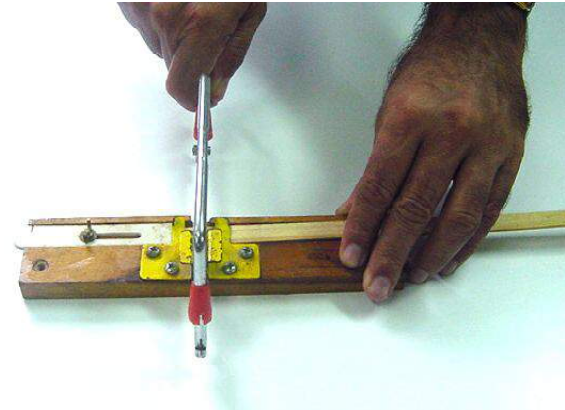
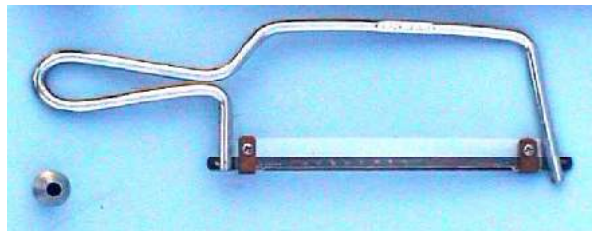

12. Strip cutting Jig:

Strip cutting jigs is needed to get the half cuts exactly without marking. This jig guides the half cut saw to make straight cuts.



13. Step making tool:

After making half cut in the strip at one end the end piece has to be split to get a step with half the thickness i.e. 1mm. A special tool is designed for this in which one end of the strip can be inserted. It splits the strip in half till the saw cut line. Thus by inserting and pushing the strip into the tool 1 mm strip can be made easily.

14. Frame Mould: Frame Mould is made in polystyrene to prevent it from getting stuck to the mould. It has 2 mm groove conforming to the frame size. Strips with half splits at either end are placed in the frame with fevicol in between. This gives exact 90° for the frame. Clips can be used to give light pressure while the fevicol dries. A small weight can also be placed on the frame for this purpose.

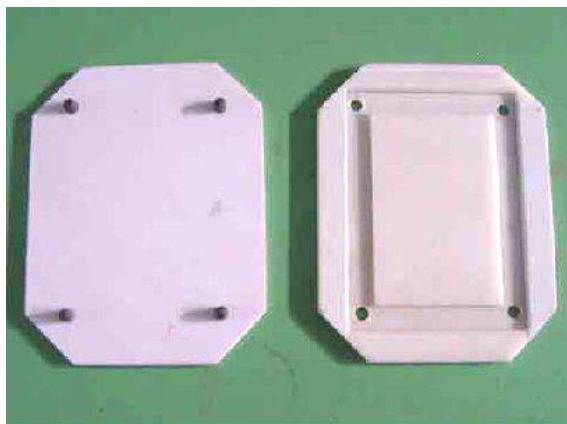

15. 'Frame ejector'
Frame ejector has four pins to push out the frames from the mould once the glue has dried. The frame ejector pins go through the 4 holes provided in the frame mould and push the frame up evenly at all corners when the 'mould' with 'frame' is placed over the frame ejector and pressed down.

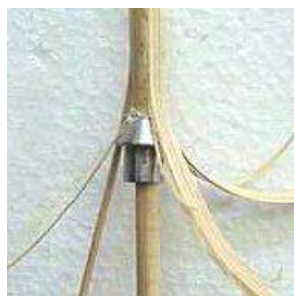

16. Round Stick making die: A die of exact dimension made in hardened steel is used to make round sticks for the hinge. Initially square sticks are made with general tools. The die can be placed in a vice and the square stick hammered through the die with a mallet to give round sticks.

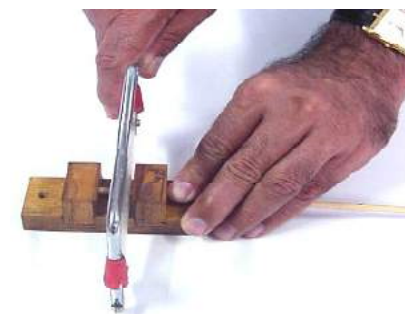

17. Slot Cutting jig: Two 20mm wide slots are to be made on the hinge rod for winding a thread to act as a hinge. For this two 1mm deep cuts are to be made at 20mm distance for each slot. A specially made jig makes it easy to make these cuts at exact position with half cut saw. The stick can be turned to get the cut all along the periphery.

18. Slot making tools: Slot making tool is like pencil sharpener with its blade equal to the width of the slot. The hinge rod after making the 1mm deep cuts for the slot, is to be kept in the tool. The tool is closed and the rod rotated like a pencil. A uniform cut of 1mm depth can be achieved by this.

Small Machines for Bamboo craft

Most of the bamboo craft work takes place in villages all over the country. Traditional craft persons have been efficient with the hand tools available. Machines, especially power operated had no role where power supply is non-existent or unreliable. Consequently 'machines' for Bamboo Craft are new to India. Countries like China have been using many power operated machines for bamboo though not necessarily for craftwork. With this background 4 hand operated machines were developed as part of the project.

1. Splitting Machine

A 'Chinese' hand operated splitting machine was located in one of the workshops attended by prof. Rao in China, (sponsored by INBAR) prior to the UNDP Project. Using the machine one can split bamboo from 4mm thickness to half (ie. 2mm) and further 2mm strips into 1 mm thin strip. The original Chinese machine is cumbersome to assemble and adjust, as the 'cast frame' in steel is not machined. The blade adjustment is tedious to make a normal craft person in a village. The structural members of the machine were redesigned for simple assembly. New type of blade fixing was developed which has clear top access to fix or remove the screws thus making it easy to adjust as well as maintain the blade.

Hardened Spring Steel used for cutter blades ensures efficiency and durability. Four rubber blocks act as springs. The weight of the machine is about 10 kgs. It can be fixed at one end of table. A 4" projection in the table is required to fix the machine.

Initially strips are to be brought to 4mm thickness with a dhau or machette to feed them into the machine. An additional device was developed to mark 4mm thickness after radial splitting and removal of inner node projections. With the help of the marking strips can be made to 4mm thickness easily. 4mm thick strips, up to a width of 30mm can be inserted into the splitting machine through the guide on one side and pushed in between the rollers while rotating the wheel with the other hand. The strip gets split into two as it gets pushed against a knife edge in the machine. The split strips come out of the machine as seen in the picture. The machine is simple to operate and can be learnt by anybody in a days time.

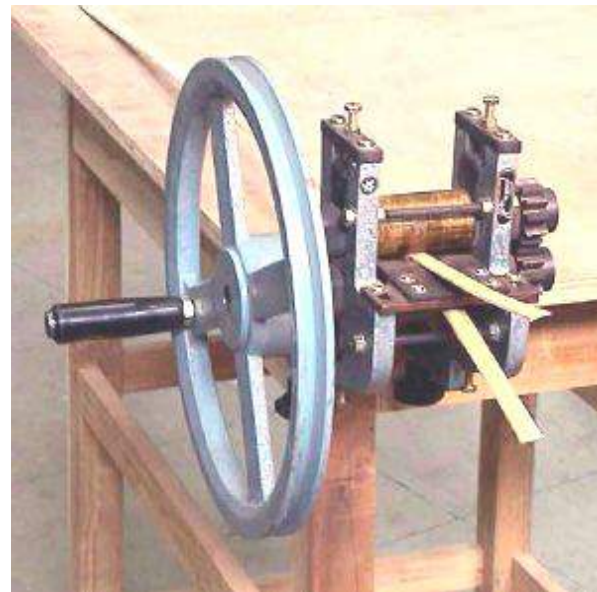
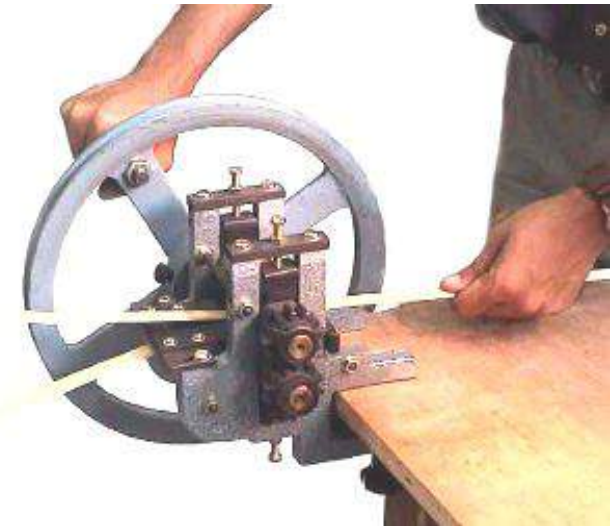

The development of the machine went through several iterations. One more modified version with rubber blocks on only one side was tried out. But the machine with rubber blocks on either side was found more acceptable as it can take green bamboo and dry bamboo as well. The gears in the machine are machined to give a 'good mesh' reducing the noise to minimum.

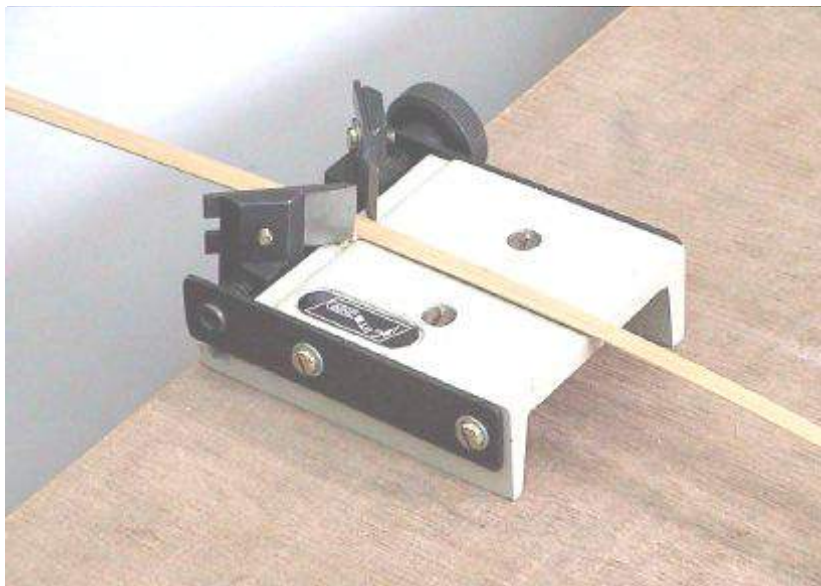

2. Width Sizer

The width sizer is of Japanese origin located in Thailand prior to UNDP project. Bamboo strips can be sized to uniform width with the width sizer. It is a handy gadget very useful for craft person to make uniform sized strips at a fast rate.

The Width Sizer was redesigned with few improvements.

In the width sizer two cutting blades fixed on metal blocks move on a screw. Screw is threaded with opposing screw thread angles on either side. Due to this when the knob is rotated the blocks move in opposite directions. A bottom groove above the blocks on the surface of the main body has been introduced to guide the blocks. The blocks are also spring loaded to ensure firm movement of the blocks without lateral shake. The body is cast in Aluminium alloy. Blades are made of hardened spring steel.

The Width sizer can be fixed with two screws on any wooden surface.

3. Thickness Sizer

The thickness sizer is also of Japanese origin located in Thailand. It has been redesigned for ease of operation with improved looks. Thickness sizer enables the user to shave bamboo strips to uniform thickness. The strips also get a smooth finish. An eccentric roller enables the thickness quickly. A wing-nut has been introduced for easy loosening and tightening. A vertical line printed on the machine helps for zero adjustment of the blade. Pictures illustrate different parts of the width sizer.



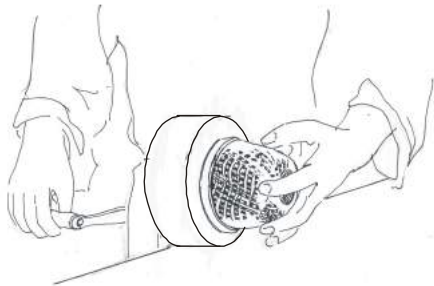

Different uses of sander

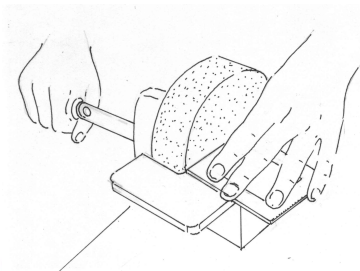
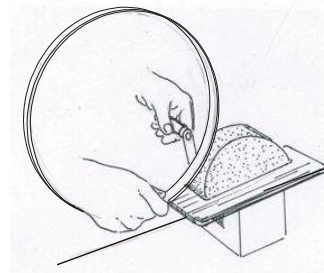

4. IDC Sander

Hand operated Sander is a new innovation made at IDC. Need for hand operated sander for bamboo craft was identified. The base mechanism of hand grinder readily available in the Indian market has been used. This gives high speed with hand rotation. A wheel made of Aluminium is mounted on the shaft instead of grinder wheel. Sand paper of good quality is stuck on this wheel. A removable wooden stand is designed to give support to bamboo pieces while sanding. Full diameter of the sander wheel can be used after moving out the stand, for special uses like sanding small basket rim. IDC sander can be fixed at one end of the table easily. 4" projection in the table top is required to fix the sander. The 3" width of Sander wheel is useful for sanding from one end. As the handle is rotated the Sander picks up speed due to flywheel effect. Fine finish can be easily obtained using IDC Sander. At the bottom a foam strip is given. Long bamboo strips can be finished by pulling them through the bottom side of the Sander wheel as it is rotated.

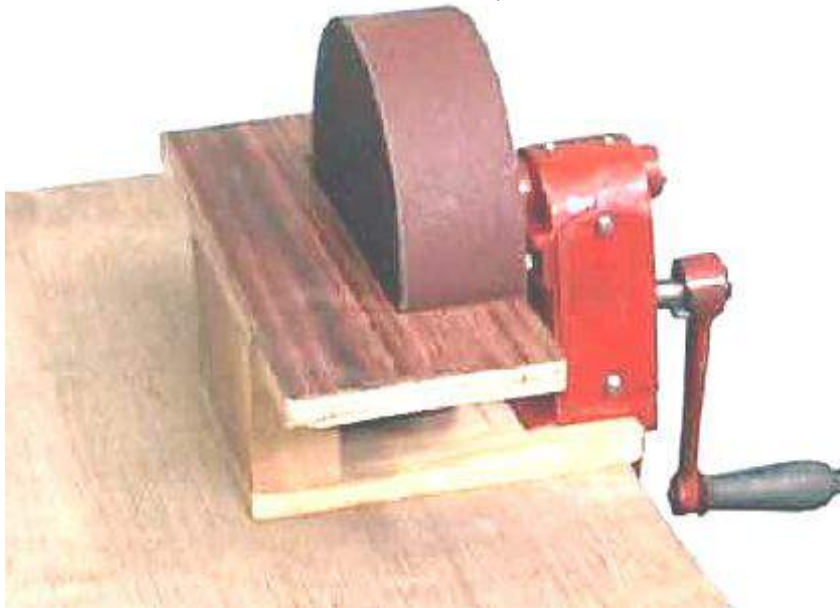

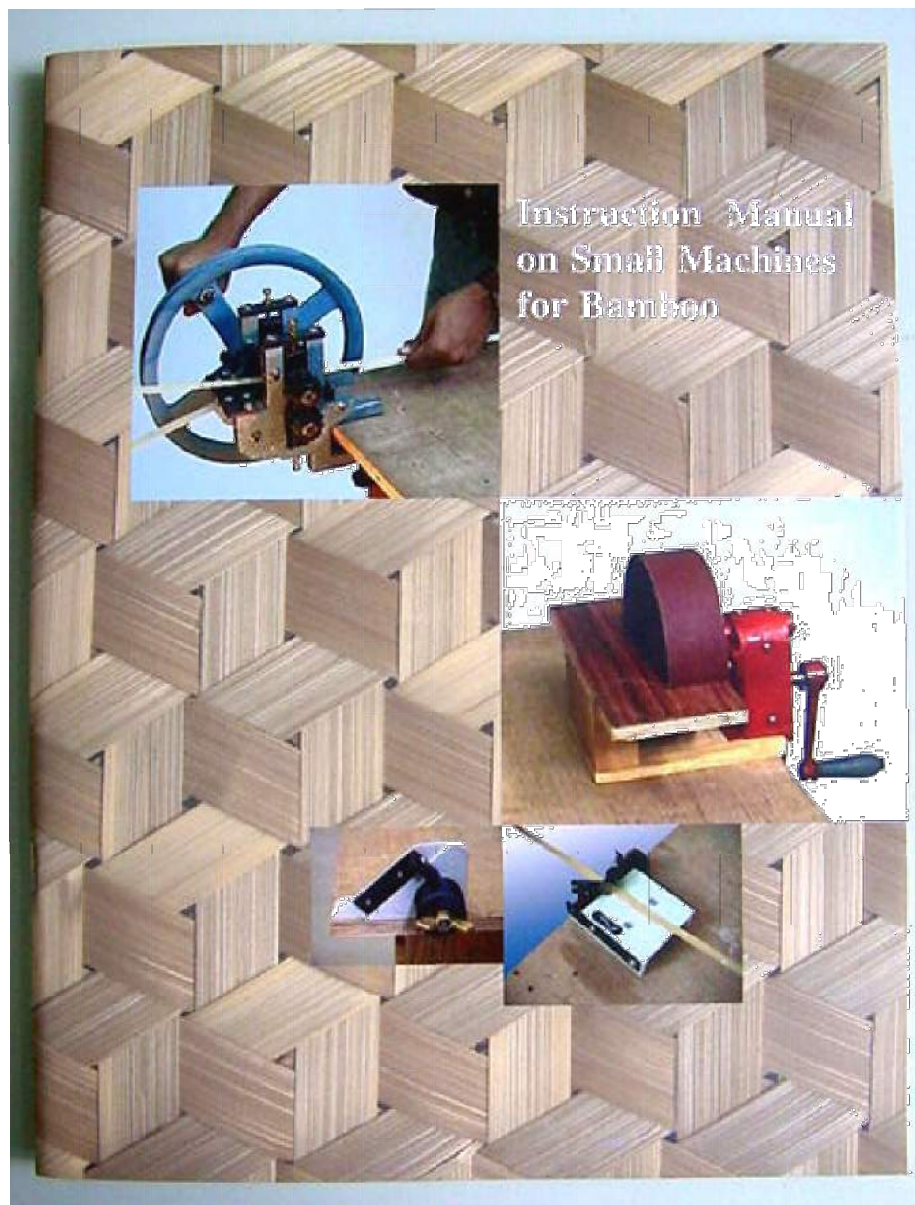

Small Machine Manual

An Instruction Manual for all the four machines was prepared as no instruction brochures are available for these gadgets. Each working operation is described step by step through line illustrations for clarity of the message. Complete maintenance and trouble shooting instructions for each of the machine are given in the manual.

Portion of a manual with illustration and text

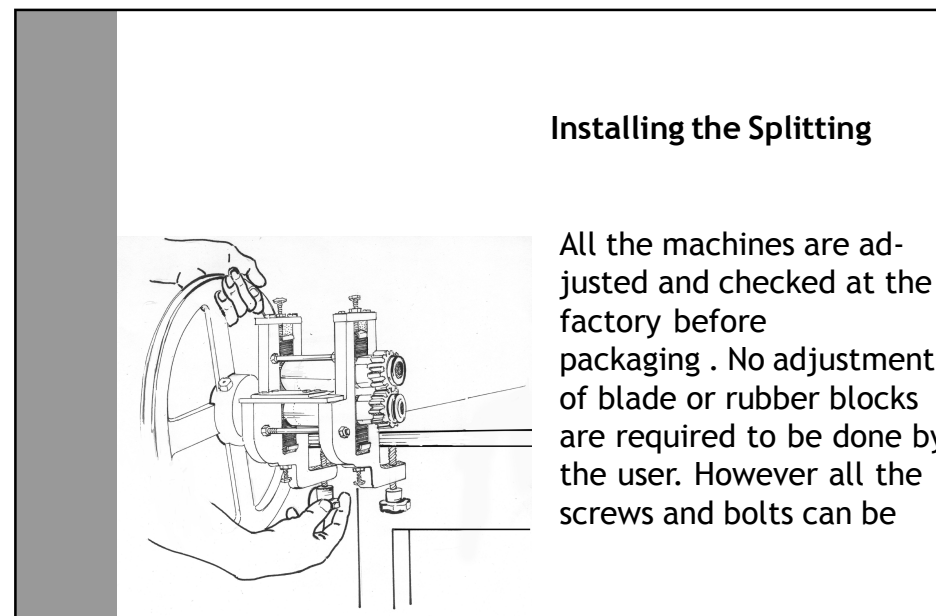

Finishes in Bamboo Craft

Finishes play an important role in Bamboo Craft. Finishes can be broadly divided into mechanical finishes, chemical finishes like colouring and treatments, Application of coatings like lacquer, paints, etc.

Set of sand paper blocks



Mechanical Finishes:

Most of the traditional bamboo craft is done in green stage. Strips are normally finished with a knife-edge, which gives a smooth finish.

Once the strips dry the unevenness of finish can be seen and felt. At the dry stage finishing with sand paper is essential for 'fine finish'. Some amount of sand paper finishing is required after a first coat of lacquer, as the fibers tend to swell.

In the tool kit a sand paper pad and a sand paper file are given for smooth finishing. IDC Sander also can be used for finishing strips.

A set of Sand paper blocks also are developed. These sand paper blocks help to finish products with curvatures.

Colouring with Natural dyes:

Among chemical finishing, colouring with Natural dyes becomes important. Several colours with natural dyes were identified and further developed. Some procedures previously developed at B.C.D.I. (Agartala), were verified and modified for acceptability for export.

The six colours are :

- Brown 1 with Katha
- Brown 2 with Tea leaves
- Brown 3 with Cow Urine
- Black with Haritakki
- Yellow with Turmeric (Haldi)
- Blue with Indigo
- Orange with Manjistha



Bamboo strips coloured with natural dyes

Colouring Manual

All the colouring procedures, as well as procedures for preservative treatments are brought out in a step by step easy to follow illustrated manual.

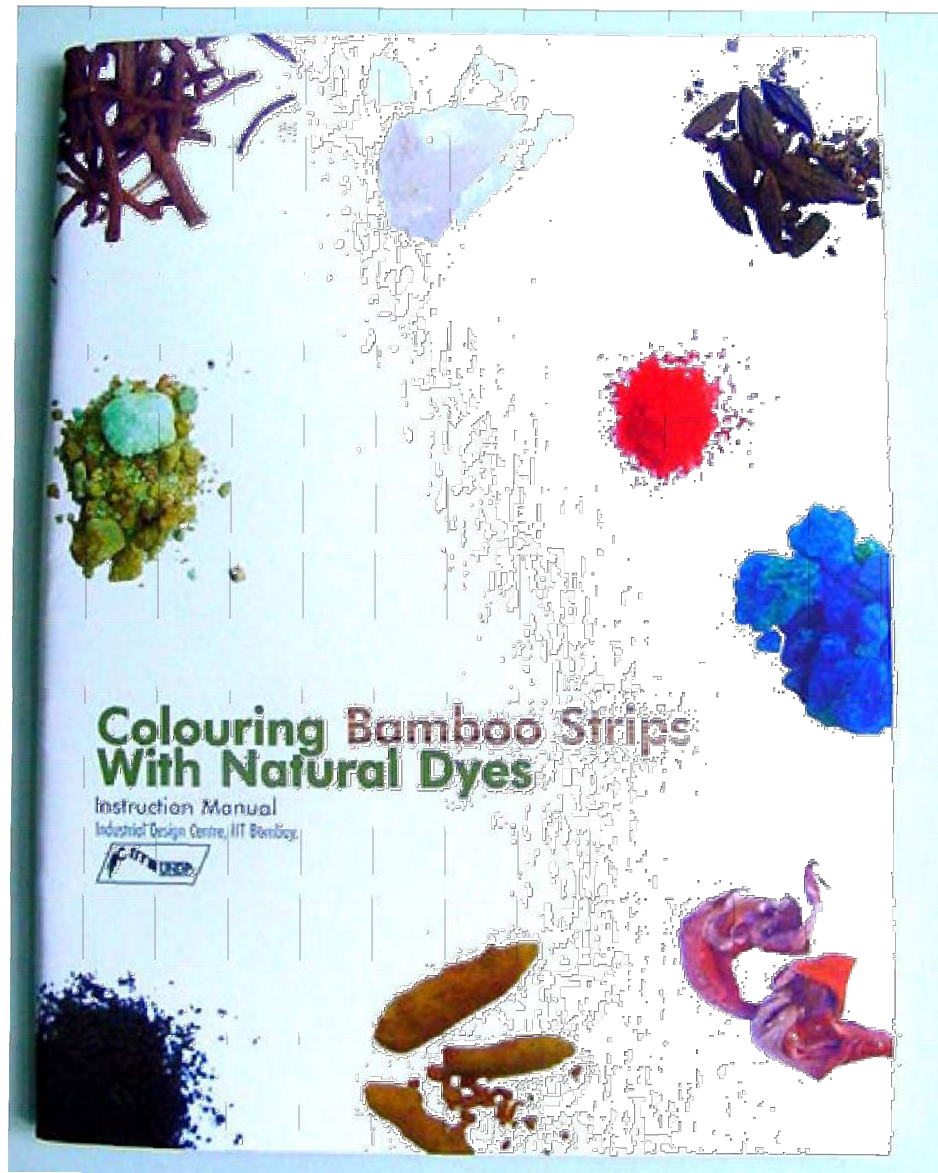

Colour fastness to light

All the natural colours tend to fade with constant exposure to sunlight due to its ultra violet radiation. Various colours obtained with natural dyes were tested for colour fastness to light and the colour fastness as per the test for each colour is given in the colour manual.

Since Bamboo Craft items are ideal ecofriendly products 'natural dyes' are used for colouring. But all the natural dyes do not have permanent colour retaining properties. For these reasons chemicals like ferrous sulphate and potassium dichromate are used as 'mordants' which help the colour retention and bonding with bamboo.

Leach Test

Whether bamboo products are safe after using mordants like potassium dichromate (though in small quantities) is important question to be addressed. For this Leach test is done on coloured bamboo to know its acceptability for different purposes. Leach test consists of keeping the coloured bamboo strips cut into small strips, in water which is stirred from time to time for 24 hours and testing the chemicals leached out from the strips into the water. Leach test helped to develop and choose colouring procedures which are within the acceptable limits.

Preservatory Treatments for Bamboo:

It is important to treat bamboo before any processing is done though some finishes do offer resistance to insect attack.

Bamboo is highly prone to fungus and insect attack due to the 'sugar' content in it. However, thin strips of bamboo are less affected as the cellulose in between the layers of bamboo reduces to a great extent in the stripping process. Two preservative treatments were developed and tested for fungus in controlled conditions with the help of a humidity chamber.

Alum test of treating bamboo strips with 10% Alum was found effective as an antifungus treatment.

Borax Boric acid treatment developed at B.C.D.I. was verified and found to be effective.

A detailed note on preservation of bamboo is given here.

Step by step procedures are given in the Colour Manual.

Preserving Bamboo

Bamboo is a natural material with certain inherent properties such as high moisture, sugar and starch content which makes it vulnerable to attack from various pests, like termites, borers and fungi.

Hence bamboo and bamboo craft products have to be treated to increase their durability, by protecting them against attack by fungi and borers.

Preservation methods have to be carefully selected. Some chemicals can be effective, but toxic and polluting to the environment and hence cannot be used for treating bamboo that is to be used in handicrafts.

Borers are responsible for over 90% of insect damages on harvested culms and finished bamboo products. By and large all species of insects have very similar life cycles. The life cycle consists of various stages beginning from egg to a larval and then pupa and finally an adult insect. It is the larval stage that causes most damage. The adults burrow through wounds, cracks or cut ends into the culm and make horizontal tunnels around culms, where eggs are deposited. Larvae bore longitudinally in the culm. Heavy infestation results in numerous criss-crossing tunnels, which are tightly filled with excreta. The fully developed larvae make chambers in which they pupate. Adults emerge out through the external rind just above their pupal chambers.

Some preventive and preservative measures have been developed against these borers in the pre-harvest phase and post-harvest stage.

Pre-harvest treatment measures are taken largely at the time of harvesting.

It is generally believed that the attack of borers on bamboos is highest when the harvesting is done during the full moon phase. Some studies have shown that the moisture level in culms increases with the waning of the moon and decreases with the waxing of the moon. This fortnightly rhythm in relative moisture content is the only lunar periodicity known to occur in the metabolism of the growing bamboo. Nevertheless, felling of bamboos based on the moon's phases is a traditional practice to reduce borer incidence, and seems to be effective in certain species of bamboo.

The timing and age of felling are very important. Culms will have less soluble carbohydrates, proteins and moisture as they get older, and they are less active physiologically in winter season and thus more resistant to the timber borers. Hence, harvesting only culms over 3-4 years old and felling at winter season are particularly recommended.

After felling, treating culms physically or chemically can significantly improve their resistance to borers as well as to fungus.

Traditional methods for Preservation

A traditional simple method of preservation is to immerse felled bamboo culms in water.

This method may be effective only in preventing damages from bostrychid beetles.

Heating of culms by fire or boiling water, or putting them under direct sunlight in hot summer can kill borers in the culms.

Chemical treatment

Chemical treatment with insecticides and preservatives has been the most widely used method in controlling post-harvest pests of bamboos.

Various preservatives have been recommended and used in different countries:

5% water solution of copper-chrome-arsenic composition (CCA);

5-6% water solution of copper sulphate-potassium dichromate-borax (CCB);

5-6% water solution of boric acid-borax-sodium pentachlorophenate in 0.8 :1:1 or 1:1:5 ratio (BBP);

2-3% water solution of borax:boric acid in 5:1 ratio; and

10% or 20-25% water solution of copper sulphate.

These are mostly applied by soaking under normal temperature, cold or heated conditions, or under high pressure.

However methods using strong chemicals like arsenic or DDT in post harvest bamboo is not advisable for bamboo to be used in handicrafts.

Chemical Treatment of cut bamboo and bamboo strips

We have used alum, borax-boric acid treatment for both cut bamboo and for strips. A six percent aqueous solution is made by dissolving 3 grams of boric acid and 3 grams of Borax in 100 ml of water. The cut bamboo and the strips are boiled in this solution for 20 minutes. Soaking of the bamboo and the strips can also be done. This treatment is effective against borers.

Boiling strips and cut bamboo in 5% to 10% Alum is effective against fungal growth up to a humidity of 80%. No treatment was found effective above a Humidity level of 80%.

In the BamBU Studio in IDC these experiments have been conducted in a controlled humidity chamber. In this chamber both temperature and humidity can be controlled and hence the efficacy of the treatment studied at various levels of humidity.

Simple methods such as storage of the bamboo in a dry and well lighted place, can also prevent fungal growth.

Smoking of Bamboo reduces the moisture content thereby preventing fungal growth.

Smoke Finish :

Smoking is a method of treatment used traditionally in North East. People smoke baskets in their houses above the cooking stove, sometimes for months.

However, a smoke chamber offers a controlled 'finish' to give required colour. Smoking also improves the resistance of bamboo to fungus and insect- attack. Smoke chamber is a simple closed room. Sawdust or organic waste is burnt below to give smoke. Bamboo craft products are loaded in the two shelves 2 feet above the burning (low) fuel giving smoke. Smoking around 8 hours gives a golden yellow finish in bamboo baskets. 14 hours of smoking gives an attractive brown colour. One can smoke further to get deeper shades of brown. Smoking also dries the bamboo fully.

A smoke chamber was designed, built and tested at IDC. The smoke chamber designed by IDC measures 4' x 6' x 8', built with ordinary bricks and mud or cement. The doors in the frame are made in sheet metal. A village mason can easily build and fit a door.



Smoked bamboo samples

Smoke chamber built at IDC



various items kept for smoking

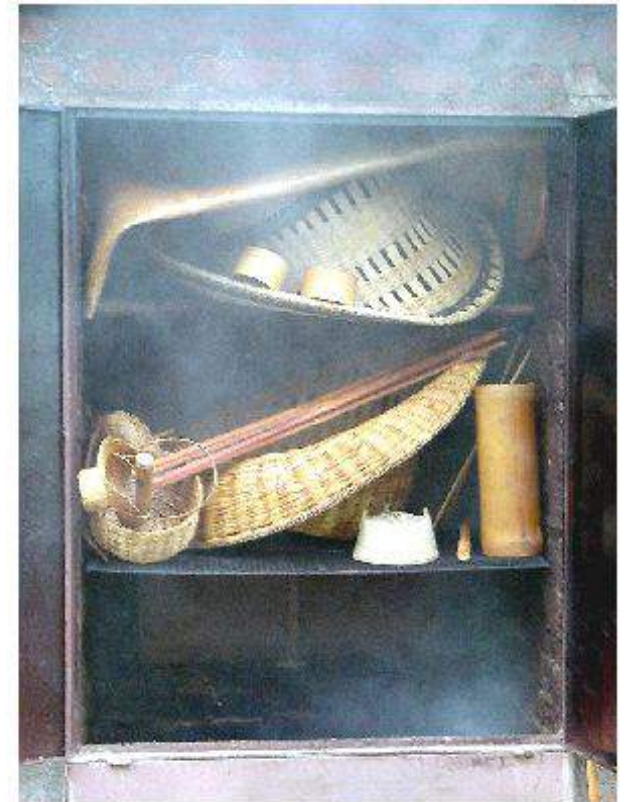

Staining Bamboo:

Wood stains can be used effectively on bamboo craft products. Special techniques of hand application can bring out the craft quality. Stains and lacquers are readily available in the market. Its use is demonstrated in various workshops conducted under the project.

Finishing with Lacquers and Paints:

Lacquering is quite common for bamboo craft products. Generally 'touch wood', an easily available clear lacquer is applied by craft persons. The glossy grade is generally used. Due to the poor pre-finish of the bamboo craft products and the fevicol applied on the product, the effect of glossy finish is uneven and unattractive.

However application of touch wood clear lacquer of 'Mat' grade gives a protective layer with a natural looking 'mat' finish.

Melamine Finish:

Melamine can be sprayed on to bamboo craft articles and a good finish obtained. If required lacquer or melamine can be sprayed on a stroked article.

Phase - II

Phase II of the project focussed on productionising of the tool kits and small machines as well as technology transfer.

Training and developing training-methods became main concerns.

The task took shape through Micro Common Facility Centres (MCFCS) three of which were taken up by IDC in North East as testing grounds

Productionising Tool Kits

50 tool kits were taken up for trial production in the second phase. Productionising tool kits proved to be a difficult task as no manufacturer was willing to take up the production due to the small numbers and uncertain future demand.

Some attempts were made to get the kit manufactured in North East. But the lack of infrastructure facility, slow pace of work made the task unviable.

Finally IDC took up the task of assigning the work to different sub-contractors in Mumbai as no single manufacturer had the ability to deal with the complexity. Tool kit has 33 items, only 12 were readily available in the market. 2 items - pruning saw and pruning scissors were to be imported. No Indian manufacturer is making pruning saw. Pruning scissors being made in the country currently were not of good quality. Several items had combination of materials like steel and wood, which made the task complex.

Following manufacturing trades were involved in the manufacture of tool kits.

Metal cutting

The IDC gauge needed a high accuracy. 'Skan-Tech' a Mumbai based company agreed, as a special case, to develop and produce the gauges with 'laser cutting'. Laser cutting facility proved to be a boon as all the tools which had cutting blades made of steel were laser cut. Laser cutting gives accurate cut with further advantage of no initial capital investment for 'Tooling'.

Following tools have laser cut steel components.

1. Half round scraper
2. Jig-plane
3. IDC width sizer
4. IDC weaving tool
5. Machette
6. Propping knife
7. IDC multi purpose knife
8. IDC fire splitting knife

Spring steel with high carbon was used in all cases except for IDC gauge which is of S.S. All the tools were hardened after grinding the cutting edges.

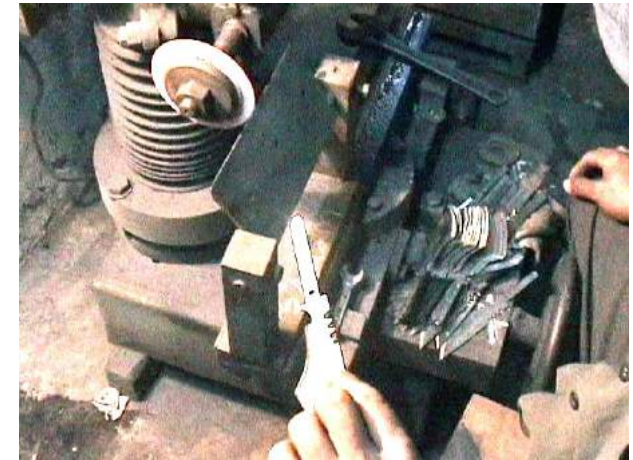

IDC multipurpose knife being ground to shape

Grinding the tools

Some of the tools like Multipurpose knife and Half round scraper were difficult to grind in the required shape without proper jigs. After trying couple of small manufacturers, Precision grinding (Rajesh Patel) took up the task.

Blackodising the steel parts:

All the blades of tools were blackodized to prevent rusting. This also improved the looks. Hardening and Blackodising were done by two separate sub-contractors.



Hot stamping:

A logo was hot stamped on all the wooden parts to give an identity to the tools.

Wooden parts

Many items had wooden parts. Round handles were to be turned. Different parties had to be assigned the task of making different parts. More sub-contractors were chosen as the 'time available was limited'.

Following tools had wooden parts.

a. Wood turning

1. Propping Knife
2. IDC multipurpose knife
3. Rasp chisel file
4. IDC piercing tool
5. IDC weaving tool

b. Wood Carpentry work

1. Key hole saw
2. IDC fine splitting knife
3. Jig plane
4. Sand paper pad
5. IDC width sizer
6. Sand paper pad
7. Machette

Grinding of Emery stones:

Emery stone in the tool kit was cut to exact angle required for sharpening the pruning saw. As the standard triangular stones were with 60° edges (equilateral triangle) a special grinding had to be adopted to get the required angle.

Screen Printing:

Templates, punched in plastic and the work board were screen printed to get the required markings.

Machettes being assembled after the parts are made in different places





shaping a laser cut blank into propping knife by the local smith

Metal shaping:

Some tools involved 3-D shaping in metal. IDC propping knife had to be brought into shape by a Smith, after laser cutting the blanks to required shape. Local Smith had a problem to bring it to the required shape in his traditional style without using a die. Few interactions with the Smith lead to develop a cast iron die which was given to him



Mr. Sawant grinding the rim binding tool to shape



Steps in shaping the the propping knife



IDC width sizer was bent to shape with heating selectively on a gas flare after laser cutting pre-hardened steel sheet to the required profile.

Rim binding needle was cut into half at one end of a steel rod and pressed. The other end was ground to a needle shape.

IDC piercing tool was ground at one end of a standard 3mm drill bit.

All the metal shaping operations demanded different vendors.

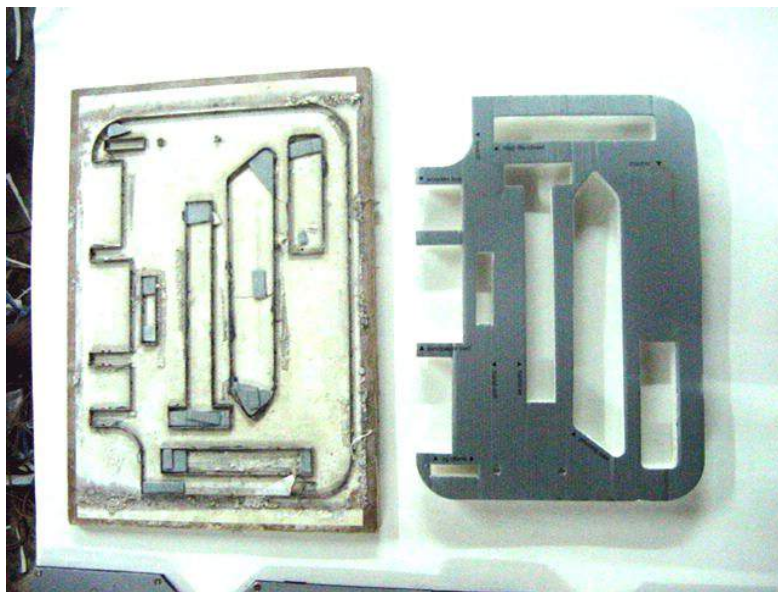

punch die and the punched bottom part to house 11 items in the tool kit

Punching in plastic and paper:

Some parts like templates were punched. A 'punch-die' was specially made to punch elliptical and circular shapes from a polypropylene sheet. Sand paper for sand paper pad and sand paper file were punched to exact shape, as it was economical and accurate process for the purpose.

Folder for Hack saw and Steel rule:

A separate Folder for hacksaw and steel rule was punched and shaped in PP fluted board.

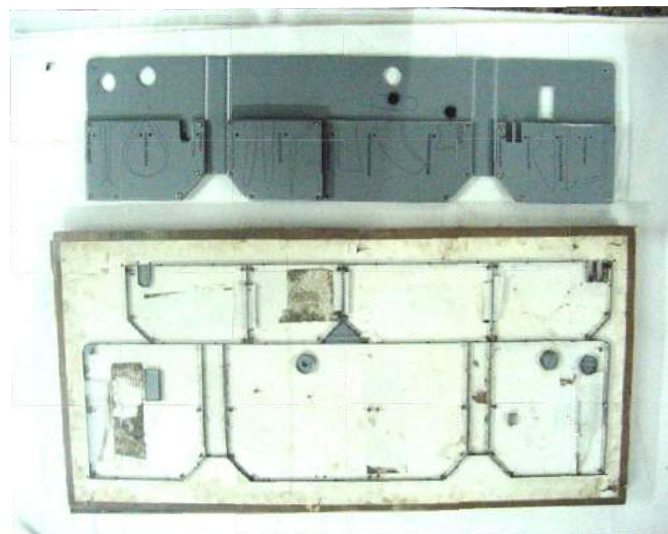

Folder for the tools

A foldable folder to keep 11 tools was developed. The folder was made of Polypropylene (PP) fluted board and foam rubber (EVA). The parts were punched with a special punch made for the purpose and assemble by riveting. The choice of Material and Process made low number manufacture possible.

Tool Kit Bag

Tool kit bag was fabricated on the lines of a standard bag incorporating few special features.

A reinforcement with 'fibre board' (PP) of 1.5mm thick was incorporated at the top, bottom and sides to give increased strength to carry the weight of the tools.

Pouches of required shape and size were stitched on inner side of the top cover to accommodate parts like work board, template, Tool kit Manual, Rasp chisel file, sand paper pad, emery stones and needle files.

A punched fluted PP sheet combined with 20mm thick foam was inserted in the bottom of bag to keep parts like Matchette, Rasp chisel file, Fevicol, Wooden box, Hand drill, Sand paper pad and IDC Width Sizer.

On the top cover of the bag a 'seethal patti' mat dyed with Katha was stitched to give a special identity to tool bag.

A powder coated frame with better detailing for fixing was incorporated inside the tool kit.



The bag being stitched at Dharavi.

Thick nylon cloth in olive green shade was chosen for the bag for durability and identity.

Specially shaped plastic legs were chosen for better looks.

legs being fixed on the bottom side of the bag



Productionising Tool Kits and Small Machines

Productionising the small machines

Productionising the small machines posed comparatively less problems as a small manufacturer Mr.Kadiru Jayaram who has a technical back ground came forward to manufacture them inspite of low margin of profit.

Splitting machine frames were sand cast and machined.Machining reduced the assembly problems.

Readily available gears were used initially. Later the manufacturer got them machined as the increased accuracy reduced the noise and effort required to operate the machine.

Rubber blocks for the splitting machine were specially moulded to give required hardness which is essential for good performance.

The other machines had aluminium castings which were sand cast and machined.

The blocks in the width sizer were further developed by 'Kadirus' by providing 'spring loading' to reduce the earlier vibrations.

IDC Sander makes use of the readily available gear mechanism in the hand grinder.

Most of the metal parts are powder coated for better finish and aesthetic appeal.All the cutting blades are hardened.

Due care is given to users' convenience by adding small accessories like spanner,glue, additional blades etc, as suppliments to the machines.

Vendor Development for Tool kit and Small Machines :

In the phase II, as the 50 tool kits were made and supplied for further distribution, concept of MCFC was proposed by IDC . IDC was also assigned to supply 400 tool kits by DC (Handicrafts) and 100 tool kits by C.B.T.C. (Cane and Bamboo Technology Centre) . In addition 36 sets of machines for 18 MCFCs by DC (H) and 24 splitting machines and 8 sets of all machines by C.B.T.C. were requisitioned.

Based on the experience and know how generated in making the 50 tool kits in the Phase II and 10 sets of machines in Phase I, two vendors were identified. Lamcraft Enterprises of Mumbai supplied 500 tool kits. Kadirus, Mumbai produced '60' sets of the 4 small machines developed at IDC. Technology transfer was effectively made resulting in good quality.

An agreement with both the parties has been reached by IIT Bombay to produce the tool kits and machines to the required quality at approved prices for a year. Tool kits and the machines are checked and certified by IIT Bombay for a small charge to ensure the quality.

Rates for selling the Tool kits and Small machines by the above parties was approved by IIT Bombay under an agreement for 1 year are given in the next columns.

Tool kit:

Manufacturer	: Lamcraft Enterprise
Address	: 12, Vakharia Industrial Estate, 1st Floor, Ram Mandir Road, Goregaon (West), Mumbai - 400 104.
Price	: Rs.5,050/-per each (retail price including taxes)
	(15% charge for retail sale + 15.3% sales tax in Maharashtra is taken into account in the above price)

Small Machines:

Manufacturer:	M/s. Kadirus,
Address	: 10-Darshan Udyog Bhavan, Safed Pool, Andheri-Kurla Road, Mumbai-400 072.
Prices:	
Splitting Machine	-Rs.4,715/- each+ taxes (retail price)
Width Sizer	-Rs.1,095/- each+ taxes (retail price)
Thickness Sizer	-Rs. 805/- each+ taxes (retail price)
IDC Sander	-Rs.1,610/- each + taxes (retail price)
A commission of 15% for retail sale over the whole sale price was approved by IIT Bombay.	

Development of Moulds, Jigs, fixtures:

Use of Moulds and Jigs for controlling shape and size is new to Bamboo Craft persons in the Country.

It plays an important role in getting exact sizes and better finishes, especially in parts like rims of baskets, plates etc.

2-D Moulds:

2-Dimensional moulds for rims of trays and baskets were developed and introduced in workshops through MCFCs. 2-D moulds for circular and elliptical shapes of different sizes were developed using new-wood. Positive moulds are used to get accurate inner dimensions and negative moulds are used to get exact outer dimensions.



Small basket with wooden mould inside

3-D Moulds:

3-Dimensional moulds are used to get the exact 3 dimensional shapes. For small baskets solid wooden moulds are made to get exact dimensions. Wooden (turned)moulds were developed for small basket and flower basket.

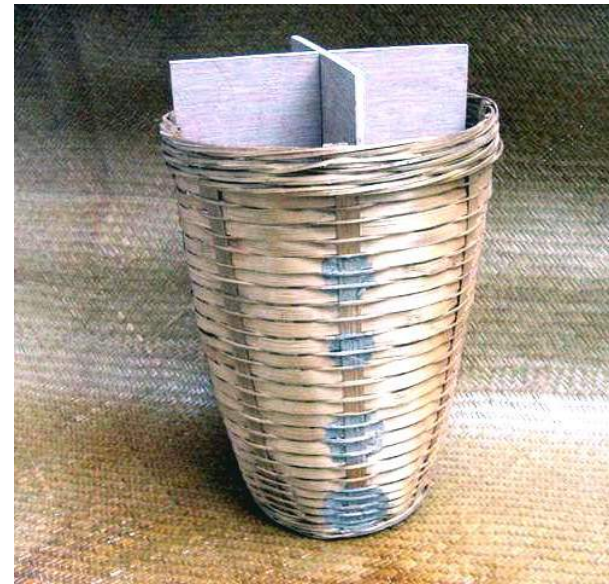

For larger products it will be more economical to use knock-down moulds made of ply wood as they would be more economical and convenient to carry after disassembling. A waste paper basket mould is seen in the picture. This mould has an advantage for weaving as it is hollow space in between the ribs.

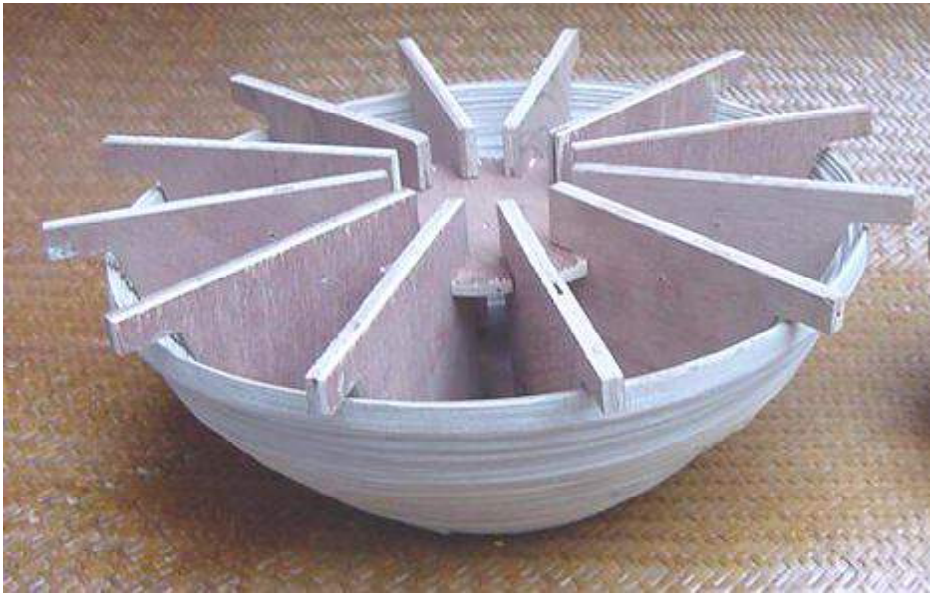

Knock down Moulds

Knock-down moulds can be made using several plates of the same shape. A knock down mould in ply wood for a bowl shape used for coil technique can be seen above. Knock-down moulds are easy to make as the cross sectional profile can be drawn on sheet material and cut easily. 2 planks like in the waste paper basket or 4 like in the mould above can be made depending on requirement..

A knock-down mould with 3 plywood planks

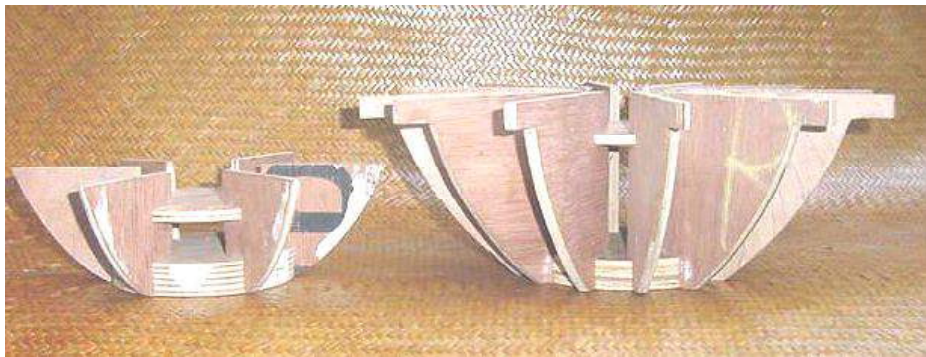

Split Moulds

Split moulds or collapsable moulds are used to make shapes with undercuts.

A classical flower vase shape is a typical example. With collapsable split moulds, central part of the mould is first removed. after weaving is completed Remaining parts collapse inside the woven basket and can be removed from the small sized mouth of the vase.

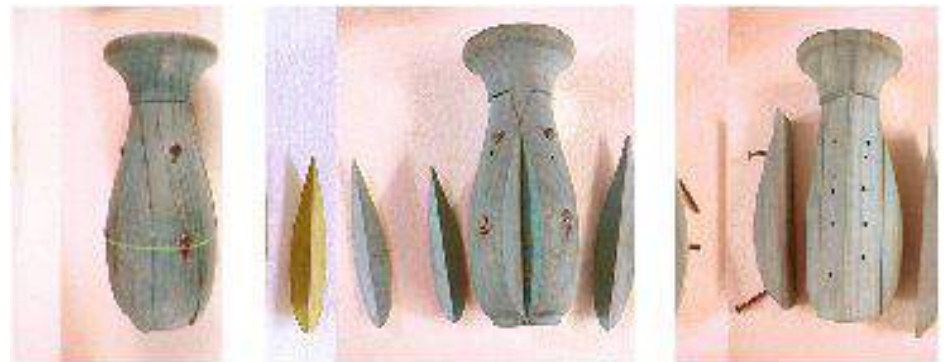

Coil Technique:

Coil technique was adopted from Thailand and further developed at Bambu Studio of IDC. In the coil technique bamboo strips are coiled around a central wooden piece, which can be rotated on a metal pin inserted in the work board.

Initially a long strip (according to requirement) is made by joining various strips in the end with fevi-quick. One end of this long strip is inserted into a knotch in the central wooden piece and wound around by rotating it. No glue is applied in between the strips at this stage. The strips are stuck in the end with fevi-quick. The coiled plate is shaped into the shape of a bowl by slowly pressing it by hand with or using a mould.

A glue paste is applied on one side or both sides after it is fully brought into the required shape. Glue paste consists of fevicol, sawdust and clay mixed in equal parts. UF resin can also be applied to get a waterproof bowl or plate.

A wooden gadget like 'Charkha' was also developed in which the strip is coiled directly onto the mould. In this case a fixing detail was developed for the central piece with bolts and nuts.



Bowl made of coil technique using a local thali as mould

Starting of a bowl



Rudrapal explaining glue mixture proportions



Development of Cane Tools

In the first phase of the project focus was on tools for bamboo. However in the tool board some of the tools were common for cane and bamboo. Some tools were specific for 'Cane'. Cane bending tool made of wood is quite commonly used by craft-persons for cane furniture. Dhau and Small Knives were used for splitting and finishing Cane. Width sizing in cane was done by pulling cane between two different knives kept at a particular angle. However an innovative combination of these knives were made use of, in Andaman Nicobar Islands by having wooden pieces to vary the height at which the cane is pulled. Since the two knives were at an angle different heights will automatically give different widths. Thus the craft person uses the 4 wooden blocks to get 4 different fixed sizes for finishing cane. from top to bottom as required to get bigger or smaller uniform width.

Based on the study of these cane tools and the general requirements starting from cutting, peeling, bending, finishing and strip making '8' tools were developed at IDC. Three variations in scrapper with different hand grips were made and used to get a feedback. 8 tools were finalised.

Set of 8 cane tools developed at IDC

cane width sizing in Andaman and Nicobar islands





Cane being scrapped at the inside curvature with a dhau at Andaman Nicobar Islands

1. Cane Scrapper

Normally scrapping is done with the dhau which has a straight edge and becomes less efficient for finishing especially at the curvatures. Cane scrapper was developed as a handy tool optimized after trying different blade profiles and grips. The blade is made of hardened spring steel. It is useful for scrapping cane in the beginning to remove skin as well as when it is bent to remove the burnt portions.



Cane scrapper developed at IDC



2. Rounding Plane :

Few varieties of Canes have tough skin. It takes longer time to scrap such cane. A half round plane with a half round blade was made to finish the round Cane. The rounding plane is effective as more force can be exerted in the push mode.



3. Pull-Push Rounding Plane :

Pull-push rounding plane is useful when the hard cane skin has to be removed in certain types of cane. It has been provided with two handles on either so that both hands can be used for operation.



4. Radius Plane:

Radius plane is an IIC innovation. It is conceived out of the need to finish bent portions of cane. Cane gets blackened when bent using a blow torch which is the common practice in India. Finishing the bent Cane becomes difficult and time consuming. The Radius plane has '3' parts connected by an elastic string. The middle part has the rounded blade. The other two parts help in guiding the plane around the curvature. The guiding helps in working with certain speed.



5. Rounding Sand Paper block:

Rounding sand paper block is half round block stuck with a cloth based sand paper across its length. It is very useful in fine finishing of Cane.



6. Radius Sanding Blocks

Radius Sanding Blocks (RBS) has 3 blocks connected with elastic string. All the blocks have half round crevice in which Sand paper is fixed. It is very handy to finish the bent cane. It is possible to reverse the curvature of RBS to finish inside the bent radius due to the elastic string connecting the blocks.





7. Width Sizer for Cane:

Width sizer for Cane is based on similar tool used in Andaman Nicobar Islands. However, in the traditional style of use at Andaman the two knives fixed in wood keep coming out after some time and the angle adjustment each time it is fixed is cumbersome and time consuming.

In the IDC design the cutting blades are bent to give a flat horizontal surface, making it possible to screw them on to a wooden base easily. The 4 wooden pieces to give different heights are also fixed with thicker bolt instead of a 'nail', which was used earlier.

8. Thickness sizer for Cane

Thickness sizing in Cane is currently done by a 'dhu' or knife placed on a bamboo or wooden block and pulling the Cane in between. The thickness sizer for cane has an adjustable blade fixed on one side of a wooden plank. Cane strip is pulled through the tool.





Cane workers at 'Cane Concepts' one

Feed back workshop at Nagaland

A feed back workshop was organized at 'Cane Concepts', Dimapur, Nagaland.

Ms. Hekali Zhimomi, M.D. of N.H.H.D.C. and other prominent persons dealing with Cane also attended the workshop.

Tools in the Bamboo tool kit which can be used for cane as well as cane tools were demonstrated and given for trials.

Most of the tools were appreciated.

Width sizer for Cane was found delicate for production run as it is constantly used.

However the idea of fixing the blades was appreciated. With the help of the IDC student, Mr. Kumaresan who was doing his summer training at Cane Concepts, a sturdier model was locally fabricated and tried out.

One more set of tools was given to C.B.T.C. for trials and feedback.

Since the U.N.D.P. Project was coming to a close, it was felt that '10' sets made may be further given by DC (H) to different groups and follow up action taken by R.D.T.D.C. for further spread.

Avinash Shinde explaining one of the tools

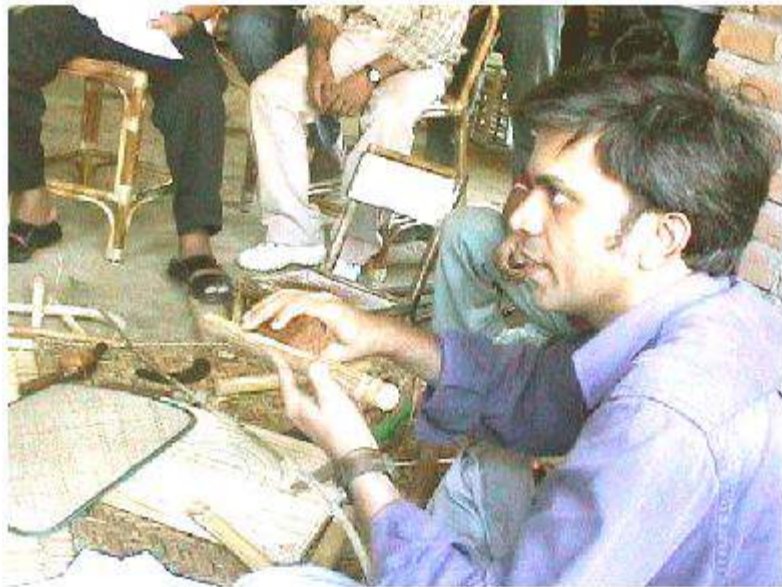

A craftsman trying one of the tools



Validation of Cane Tools

'Cane Tools' were demonstrated in the workshop held at 'cane coopts' in the morning session. In the afternoon detailed discussion was held with the craftsmen of the 'Cane Concept' regarding the use of these tools. They also made use of these tools and gave the feedback. The following tools were demonstrated.

1. Scrapper
2. Rounding Plane
3. Hinged Plane
4. Rounding Plane with Handles
5. Rounding Sandpaper Block
6. Hinged Sandpaper Block
7. Cane Width Sizer
8. Cane Thickness Sizer

feedback

1. Scrapper:

- Scrapper should have 2 handles.
- It should have different radii to fit bigger or smaller size cane

2. Rounding Plane

- Bigger size than the existing one is required. 1½ times of the existing size is preferable.
- Blade should be tightly fixed
- Blade should project out little more.

3. Width Sizer

- It should be adaptable for wider strips of cane as well.
- Double size of the existing one is preferable.
- It should be sturdy.

4. Thickness Sizer

- Blade can be variable (movable) so that the thickness of cane pulling can be varied.
- It should be sturdy.

There was no significant feedback on the other items. Generally they seem to accept the other tools. Certain tools from the 'Tool Kit' like multi purpose knife were also highly appreciated.

In the next couple of days the craftsmen at 'Cane Concept' themselves modified these tools based on the concepts given by us with the help of one IDC Student Mr. Kumaresan who was going through practical training at 'Cane Concept' for a month. These modifications have been documented on the Video.

**Micro Common Facility Centres
(MCFCs) :**

MCFCs were suggested by Prof. Rao during the UNDP project to introduce tool kits and Small Machines developed at IDC with a proper context. This idea was accepted by DC (H) . Consequently 18 MCFCs were sanctioned for N.E. Since the concept was new 3 were taken up by IDC for trial implementation.

MCFCs are small village units which may or may not have electric supply. A typical unit is to cater to the needs of 15 to 25 artisans. A work shed was to be provided by N.G.Os, entrepreneurs or state governments. The tools, Small machines and Technology and Training was provided by D.C. (H) through IDC.

3 MCFCs were taken up at Dizehephe (Nagaland), Nalchar (Tripura) and Barapeta (Assam) supported by N.H.H.D.C., Poorbasha and SaptaShree (a private entrepreneur) respectively.

The concept of MCFCs as given in the next pages, was circulated to concerned officials and the Societies running the MCFCs. Visits were made by Prof. Rao to each of these places to explain the groups what it means to have an MCFC, as the concept was new.

Cocept Document for MCFCS

M.C.F.Cs are conceived to cater to the needs of bamboo craft persons in the remote villages. Each MCFC will have hand-operated machines, Hand Tools, Jigs and Fixtures as well as a Smoke-chamber for collective use of around 15 craft persons who could form a Cooperative Society. The number can increase with proper planning of the utilization of facilities.

A model lay out for the facilities is suggested. However, the facility can be built into existing 'structures' with proper planning and modifications.

M.C.F.Cs need to be seen as instruments to induct new culture of upgrading bamboo and cane craft on a self-sustaining basis. They will become organizing units for bamboo craft to compete with the industrial products in the global markets. M.C.F.Cs can become "windows" to the out side world for the craftpersons in remote villages to recieve Design, Technology, Training and Marketing inputs on a continuous basis. In due course they will be 'profit' making units, able to hire all such Services.

Each M.C.F.C. can specialize in a product line to capture a market-share. A 'design strategy' based on strengths and weakness of particular group is essential for such achievement.

M.C.F.Cs can become centres to procure orders and new designs. They can stock components of products in other materials like jute, brass, powder-coated steel for the use of crafts persons. Availability of such components and materials which are not

readily available in the local markets, will become a major factor to compete in the Urban Markets. Products from each MCFC can go with a 'brand mark' ensuring certain standard of quality and reliability to ensure continuous orders.

M.C.F.Cs can also become experimental grounds for introduction of distant education in bamboo craft.

For the success of M.C.F.Cs, an integrated approach is essential.

1.0. Various facilities which will be given to each M.C.F.C.

1.1 Hand operated Machines

Two sets of Four Hand operated Machines will be given to each M.C.F.CS.

1.1.1 Hand operated Splitting Machine

1.1.2 Width Sizing Machine

1.1.3. Thickness Sizing Machine

1.1.4 Hand operated Sander

1.2 Hand operated Drilling Machine

A hand operated bench drill with 2 speeds.

1.3. Tool Kits

Tool kit has 33 items in a special bag. Two of this will be given to each M.C.F.C.

Tool Kit items:

- | | |
|----------------------|--------------------------|
| Adjustable Hacksaw | Jig Plane |
| Foldable Pruning Saw | Machete |
| Mini Hack Saw. | IDC Multipurpose Knife |
| Key Hole Saw | IDC Fine Splitting Knife |
| .Hand Drill | IDC Width Sizer |
| Hammer. | Pruning Scissors |
| IDC Piercing Tool | IDC Gauge |
| Rim Binding Needle | Inside Calipers |
| Fevicol | Outside Calipers |
| Small Box | Steel Rule |
| .Templates | Measuring Tape |
| Compass | Sand Paper pad |
| IDC weaving Tool | Sand Paper file |
| Propping Knife | Needle files |
| Work Board | Chisel Edged Rasp File |
| Sitting Mat | Emery Stones |
| Half Round Scrapper | |

1.4. Additional Tools

5 other tools which have specific use for the cluster.

1.5.Vices: Two bench vices.

1.6.Work bench:

Two work benches of 1'x4' and 4'x4' will be given on which all the machines and vices will be mounted as shown in the plan.

1.7.A small Cup Board for Tools

A small cup board to store tools and components required for the craft persons.

1.8.Jigs and Fixtures

General jigs and fixtures for making rims of baskets will be provided.

Product specific jigs for specific products will also be provided.

1.9.Smoke chamber

A smoke chamber to smoke baskets will be given.

Model Smoke Chamber has overall dimension of 3'x4'x6½ built in brick. Fuel is put in the pit at the bottom. 4'x3'x4'. i.e. 48 cu.ft. is provided for smoking. Racks inside will facilitate keeping of bamboo items.

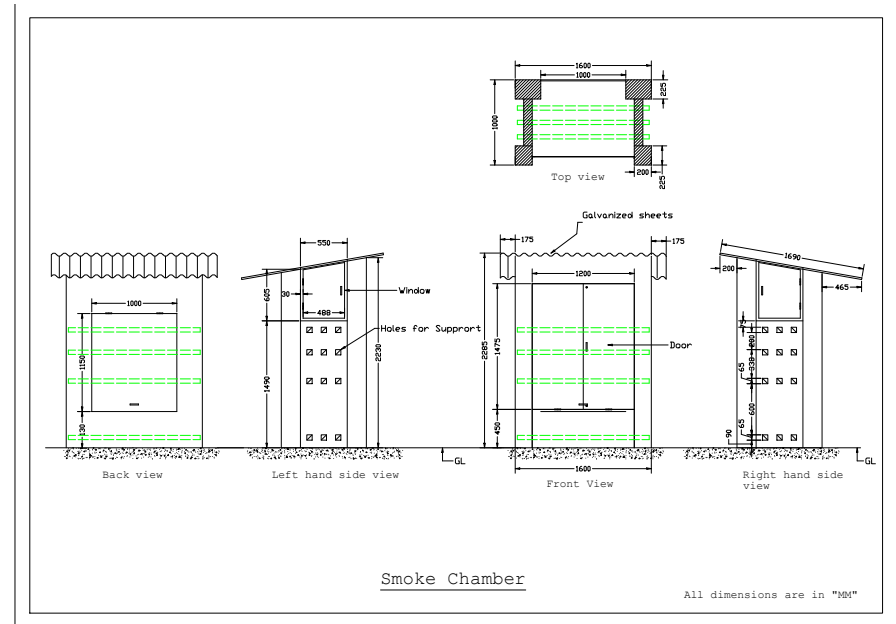

2.0. Facilities to be provided by local Govt., N.G.Os or Craft Societies.

2.1.Space, Shed

A model lay out with 15'x30' covered area is suggested as shown in the plan. It can house '8' craftpersons working on machines, '8' persons weaving and 4 to 5 persons making rims and finishing. Spaces for semi-finished and finished material are given. Bamboo treatment, dyeing and smoking will be done out side the shed.

lay out plan for MCFC

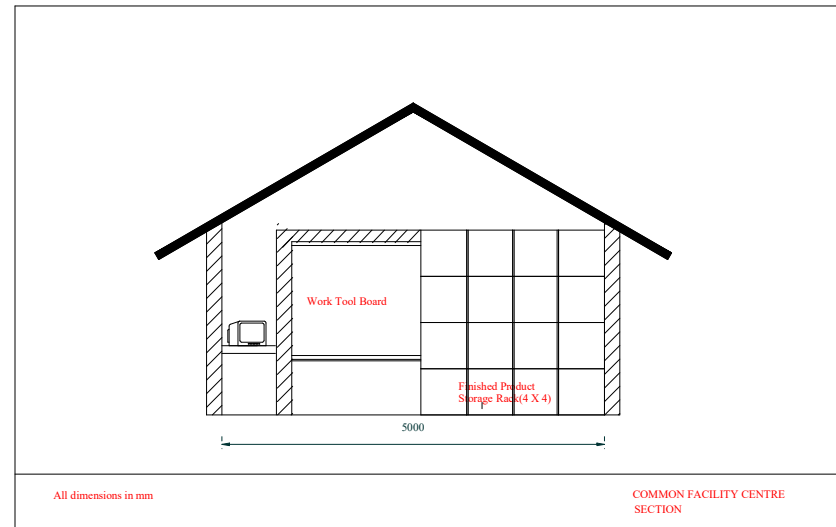
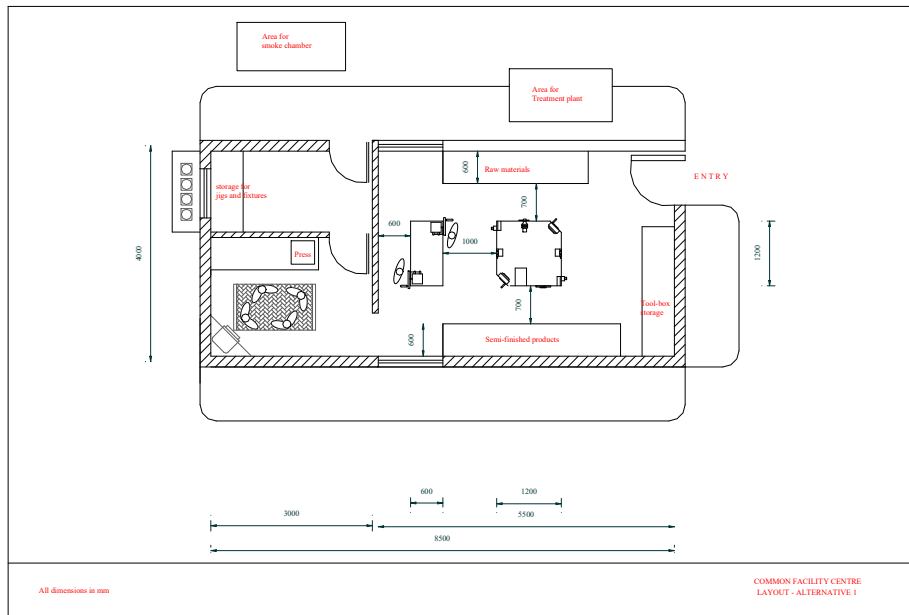

Cross sectional view for MCFC with storage space for finished goods

1½' x 1½' x 1½' carton boxes will be used by each craft person to store each day's produce. 15 to 18 such boxes can be kept in the area provided for the purpose. Simple racks are adequate to keep the boxes. Drinking water, toilet facilities need to be provided though not indicated in the lay out.

2.2. Water and Electric supply

Electric supply is not essential as all the machines are hand operated. Where electricity is available it is handy for better lighting and adding power operated tools later.

Normal water availability is enough for natural dye finishes and even treatment.

2.3.Raw material storage

Large raw material storage is not anticipated as each craft person can bring or handle their own raw material. If needed they can develop storage facility out side the shed.

2.4.Transport

Access to transport will be an asset to take out the finished goods for out side marketing.

3.0.Design and Training facilities:

Design and Training facility will be given to M.C.F.Cs under different schemes of U.N.D.P. through D.C. (H), C.B.T.C. and IDC, IIT Mumbai.

Lay out for work-tables with machines

A lay-out plan for two tables with machines is suggested. However the lay outs can be worked out as per the local convenience. Care in planning needs to be taken to provide a free flow of raw material as well as people.

A table of minimum size is also suggested. If space is available a bigger table can be used as it can give more stability while operating the machines.

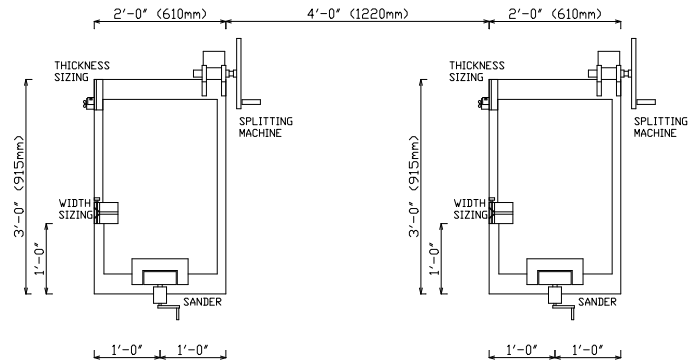

PLAN

SMALL MACHINES WORKTABLE FOR THE MICRO-COMMON FACILITY CENTRE

BAMBU STUDIO
IDC, IIT BOMBAY

Table

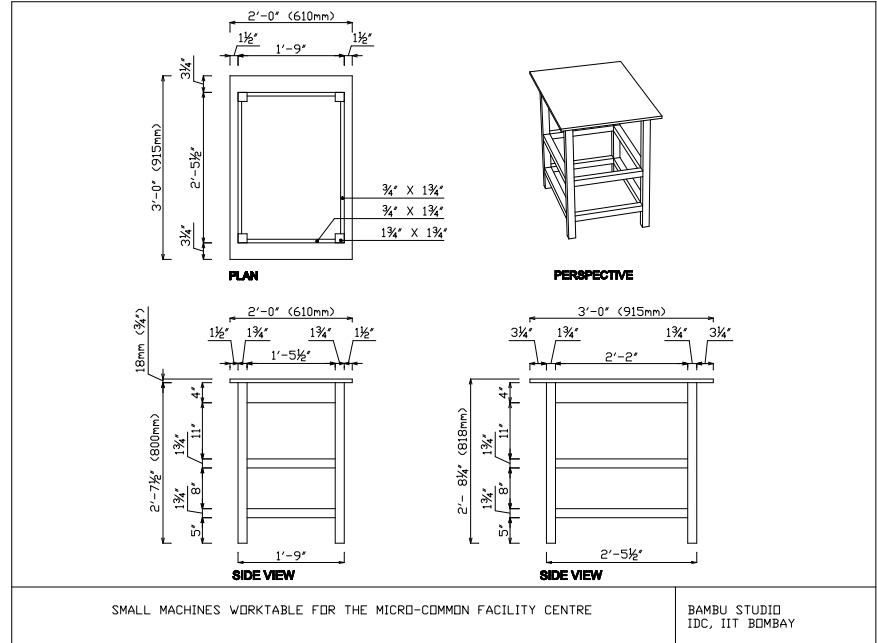

PLAN

PERSPECTIVE

SIDE VIEW

SIDE VIEW

SMALL MACHINES WORKTABLE FOR THE MICRO-COMMON FACILITY CENTRE

BAMBU STUDIO
IDC, IIT BOMBAY

MCFC at Diezhephe (Nagaland)

Diezhephe is a newly formed village with the settlers who came out of insurgent groups. A Common Facility Centre was already built under Nagaland Handloom and Handicrafts Corporation (NHHDC) grant for woodwork. The suggestion for MCFC came from NHHDC due to the infrastructure which was already available. This village is only around 20 km from Dimapur by road.

Craftspersons at Diezhephe were working only in wood. Bamboo was an additional new venture though most of the Naga craftpersons know bamboo weaving. The chairman of the Diezhephe Craft Society is a dynamic person. All the persons were warm, friendly and had lot of respect for Ms. Hekali Zhimomi, Managing Director (M.D.) of NHHDC. Having a dynamic officer at the helm of NHHDC helped in setting up MCFC.



prof. Rao with the craft group



Chairman of Diezhephe



Diezhephe workshop. Sunder and rudrapal working with the group

Social Response

M.C.F.C. became a focal point for creating faith in Bamboo Craft and Bamboo products at Diezhephe, as there is need for bringing value to the declining traditional culture.

Prof. Rao made visits to Jalokhi, Moccockchung, Khonoma, Wokha and Lakhoti villages. Ms. Hekali Zhimmi, M.D. of NHHDC accompanied to some of these places. Large gatherings at each of these places were shown the new tool kit with demonstration.

One-day workshops were also held at Dimapur for the local craft persons. Local newspapers highlighted the efforts on bamboo craft and Future possibilities. N.H.H.D.C. has been selling the 'coil technique' bowls made by one entrepreneur at Jaloki. Diezhephe group has been locally marketing the bowls and plates.

The M.C.F.C. has also paved the way for increased acceptance and demand for new tool kits which are distributed by D.C. (H). It has also resulted in increased interactions of I.D.C. with N.H.H.D.C. 3 M.Des Students spent one month in Dimapur and Dizehephe in 2002 and one student spent one month in Dimapur in 2003 as part of their training where they assist local design efforts.

Design Approach

A new design approach was taken for Diezhephe by introducing bamboo and wood combination products. A coil technique bowl was initially developed at IDC and introduced. Later after looking at the Naga traditional bowls, a combination of wood bottom with Naga Carving was incorporated. Thus the new 'Naga bowl' saves lot of wood as a big log need not be chipped off, for making a bowl. Bamboo combination with coil technique replaces major part of the wood in addition to providing a new look. The bottom wood part and the wooden lid make the bowl a value added item which has an urban market potential.

Coil technique plates were also introduced at Diezhephe. A new basket with a wooden base was another new introduction. Naga craft products are known for 'good quality and high cost'. It is important to keep the high quality as the local carving skills and cultural identity have a value in the local as well as urban markets out side. The products need to be marketed as high end products.



simple bamboo bowl in coil technique

a craftsman carving the bottom of Naga bowl



finishing the bowl



Naga Bowl





tray with 3D weave was introduced at Dizhephe

Diezhephe unit already had power supply and 5 to 6 power operated machines like lathe and sander.

The following Tools and Machines were given to the Unit.

Tables were financed as they were made by them.

A Smoke Chamber of their own adoption was built as Nagas have a tradition of smoking baskets at their homes.

Tools/Goods given to Diezhephe :

Item	Qty.
1.Tool Kits	2 nos.
2.Splitting Machine	2 nos.
3.Width Sizer	2 nos.
4.Thickness sizer	2 nos.
5.Sander with Table	2 nos.
6.Strip Roller	1 no.
7.Hand Grinder	1 no.
8.Photo Cutter	1 no.
9.Hole Saw	2 sets
10.File Frame Jigs	2 sets
11.Flower Basket Moulds	2 nos.
12.Knock Down Mould	2 nos.
13.Bowl Mould	1 no.
14.Oval Tray Mould	2 nos.
15.Round Stick Making Tool	1 no.
16.Elliptical Jigs (Small acrylic tray)	1 no.
17.Circular jigs	1 no.
18.Drill Bit Set	1 no.
19.File set	1 no.
20.Needle File Set	1 no.
21.Helliex Small Drilling Tool	1 no.



Bamboo container with Naga motifs



Rudrapal showing a detail to Mr. Puroh

young craftsman learning coil technique

Training:

Training workshops of week-long duration were held twice at Diezhphe. 4 persons were called to Mumbai for week-long workshops where they were trained along with craft persons from Assam and Tripura, Kerala, Gujarat and Maharashtra. Along with Diezhphe Craft persons, 4 entrepreneurs from Nagaland were called to the workshops at IIT, Mumbai for training with the help of NHHDC. These entrepreneurs came with their own expenditure. The combination of 2 craft persons and two entrepreneur craft persons each time made travelling and reaching Mumbai easy for the craftsmen. The exposure to Urban Markets and small Industries at Mumbai were rewarding experiences to the craft persons. The entrepreneurs also were helped to purchase the tools of right quality at the Bombay market.

Mr. Alan trying IDCSander at workshop held at IDC

Mr. Puroh and others at IDC workshop



M.C.F.C. at Barapeta (Assam) :

M.C.F.C. at Barapeta was located at 'Sapthashree Handicrafts' belonging to a local entrepreneur.

The entrepreneur employs 7 to 8 persons.

The unit also caters to many villages around as the unit 'acquires' products from them and supplies to NEHHDC .

'Sapthashree Handicrafts' has been a supplier of various bamboo products like lamps, trays to NEHHDC for long time.

Several 'design inputs' in the past have been given to the unit through D.C. (H) design schemes. The unit had enough space for M.C.F.C. Incidentally a Common Facility Centre by D.C. (H) was also started at the unit. A smoke chamber was built by Saptharshee as per IDC design.

Smoke chamber built being modified as per requirement





New Designs

Products with Coil Technique had a strong impact on the craft persons. The craftsmen adopted the technique and developed new designs of their own like elliptical tray with the cane weaving (introduced by IDC based on Khonoma weave) for the handles. Other products being made by the unit were also studied. Design improvements were suggested for easy manufacture and better finish using the new tools and machines given to the unit.



Rudrapal showing the rim making

Training

A week-long workshop was held at 'Sapthashree' premises in which several craft persons participated. Mr. Pradeep Babar, A.D. at D.C. (H) office in Guwahati was also present on the Inaugural day of the workshop.

Rim finishing being demonstrated



Craft persons were trained in the use of tool kit as well as Small Machines. Coil Technique was introduced to the group. 2 persons from Sapthashree attended a week-long workshop in Mumbai. '2' persons missed the first workshop as they cancelled their trip in the last minute because they were asked by the NEHHDC officials to attend a 'Market meet' at the same time.

Haldar demonstrating treatment of bamboo



The craft persons in general at Barapeta use 'Gamaxin' for treating bamboo. **Gamaxin is a banned item now all over the world as it does not 'bio-degrade'.** Borax, Boric acid treatment was introduced to the group. The coil technique bowls are being made and sold in the local market by Sapthashree. Mr. Mohibul Hussain, the owner-craftsman who attended workshop at Mumbai is very enterprising and is 'training' other craft persons in coil technique for NEHHDC after attending the IDC workshop.



Haladar telling how to use the gauge

Craft persons were trained in the use of tools and machines



craft persons trying the splitting machine



Ali cutting with pruning saw

Sundar explaining a point to Ali





M.C.F.C. at Nalchar (Tripura) :

The M.C.F.C. at Nalchar was taken with the suggestion of D.C. (H) and Parbasha (State Govt.) An existing Society at Nalchar which had a building was identified. Prof. Rao visited the place initially and suggested expansion of space as MCFC needs open space to work. As the current building was built as storehouse there is no ventilation in the unit.

A meeting was held with Mr. Battacharjee, Director, Industries who promised that the bigger place will be built, as an extension of the existing unit.

However, no progress was made after 6 months.

Mr. Bhattacharjee had retired and the new person was not aware of the promise. Since the project had a limited time frame, Tool kits and Machines were sent to Tripura. A workshop was planned. Unfortunately the workshop was called off at the last moment due to insistant demand from D.C. (H), as new B.C.D.I. programme was being inaugurated by N.I.D. few days after the workshop. The craftsman who had already reached Kolkata was called back.

M.C.F.C. at Tripper got slight set back due to the above reasons and the volatile, uncondusive situations during local election which limits the 'timing' for holding the workshops.

However the required tables for the machines were made. Tool kits, small machines and other tools were given to the Women's Society at Nalchar.

Tools/Goods given to Nalchar Women Hasta Kala Silpa Sabha Samiti Ltd., Nalchar Tripura

(W) :

Description	Qty.
1. Splitting Machine	2 nos.
2. Width Sizer	2 nos.
3. Thickness Sizer	2 nos.
4. Sander with Stand	2 nos.
5. Tool Kits	2 nos.
6. Spanner	1 no.
7. Screw Driver	1 no.
8. Rubber Blocks	4 nos.
9. Emery Paper for Sander	4 nos.
10. Hand Grinder	1 no.
11. SR 998	100 Gms
12. Tray Moulds (Round, Oval, Square)	1 set each
13. Product Specific Tools	1 set
14. Strip Cutter	1 no.
15. 4mm Marker	1 no.
16. Mould for Gift Basket	1 no.
17. Mould for Gift Basket Rim	1 no.
18. Paper Basket Rim Mould	1 no.
19. File Cover Styrene Jigs	1 set
20. Acrylic Sheet	2 nos.



Mr. .M.L.Das



An instructor at BCDI

Master Craftsman Krishnadas pal



Training workshop at BCDI, Agartala

A 2-day workshop was held at B.C.D.I. on tools and small machines in which local craftpersons, B.C.D.I. instructors, B.C.D.I. Students attended the workshop.

Mr. M.L. Das, Director of Industries inaugurated the workshop.

A full set of Tools, and a set of Machines were given to B.C.D.I. to be used in their Training programme. N.I.D. Faculty who have undertaken the training programme of B.C.D.I. were also present in the workshop and extended their support in visual presentations. Mr. Pulaha Dasgupta gave a brief introduction of the N.I.D. work.

New Designs

Tripura has the highest potential for adopting the new designs. The small basket with lid, newspaper basket, Note pad, File cover were introduced. Coil technique was also introduced.



News paper basket with different hangers

Tripura basket with lids

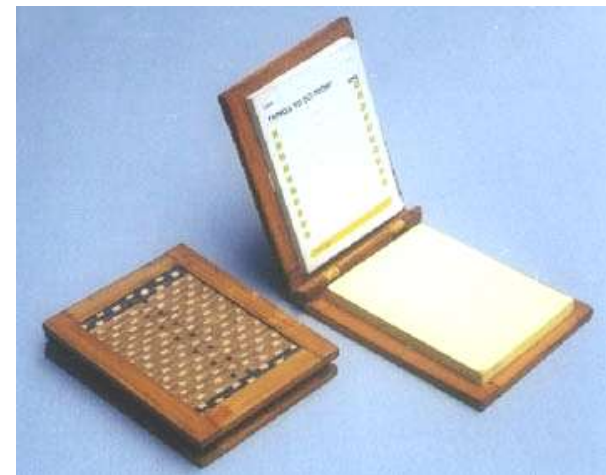

Note pad

File cover with jute hinge

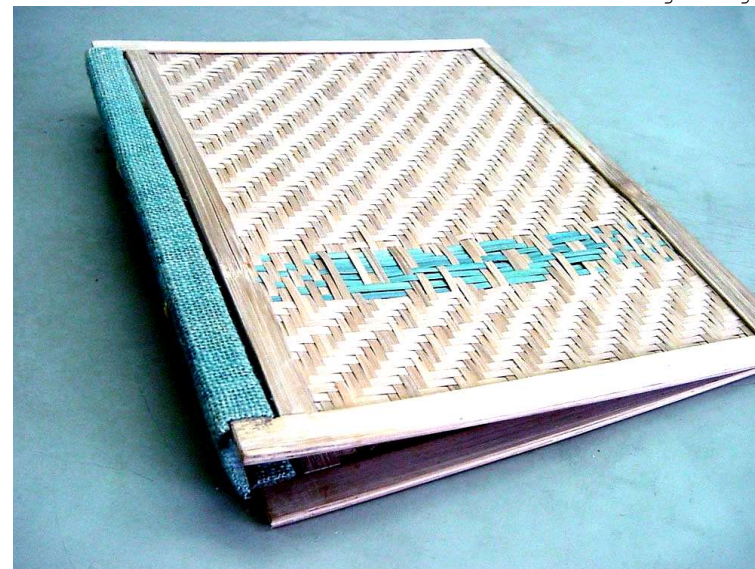

M.C.F.C. at Nalchar

prof. Rao explaining the group



Craft person trying width sizer

Workshop at Nalchar

A week long workshop was held in Nalchar in which several craft persons attended from Nalchar. They were trained in the use of Tool Kit and Machines.



Two Persons from Tripura were also trained at Mumbai for a week in use of Tools and Machines.

learning the use of splitting machine



Rudrapal demonstrating coil technique



Conclusion

Both phase 1 and phase 2 of the project, 'Tools ,Technologies and Finishes ' have been successfully completed.

Setting up three Micro Common Facility Centres in North East has also been completed.

550 tool kits have been made and supplied.

60 sets of small machines have been made and supplied.

Three manuals on use of tools, Small machines and Finishes in addition to a general brochure have been brought out.

Technology Transfer for manufacturing tool kits and Small machines has been done successfully.

Two small manufacturers are making and Supplying Tool kits as well as Small machines at Mumbai .

8 Cane tools have been developed. 10 sets have been made and supplied after validating them.

MCFCs were assisted in Technology and Designs. Training in using the tools and small machines was given. New product designs and supporting technologies like moulds, jigs and special tools were also given to each of the MCFCS .

Continuation of work with these MCFCs and setting up new MCFCs are being handled by DC (H) officials now.

Tools, small machines and finishes developed have made an impact judging from the continuous requests received by Bambu Studio of IDC for conducting workshops as well as setting up MCFCS. Continuous queries for supply of tool kits and small machines have also been coming from individuals as well as various agencies.

The details of the workshops conducted along with names and addresses of craftpersons who attended are given in the annexures.

'Get up' Programme

Day - 1

9.00 to 10.00 -	Inauguration	S.P.Sarma,M.D.-NRFDI
10.00 to 11.00	-Importance of product get-up. Products from Indonesia, Thailand, Costa Rica, China & Japan. Use of Tools, Machines & finishes. Bamboo Products, Tools & Machines developed at IDC.	- Slide + Video talk - A.G. Rao
11.00 to 11.15	Tea	
11.15 to 12.00	Demonstration of · Splitting Machine · Width sizing Machine · Thickness sizing Machine · Sanders · Hand Tools	- Rudrapaul (Craftsman) Avinash (Designer)
12.00 to 1.00	Participatory Workshop	- A.G. Rao Sukumar M.S.G.Rajan
Lunch		
2.00 to 3.00	Demo of Natural Dye Colouring	- Rudrapaul
3.00 to 4.00	Practice Session in small groups on tools and machines	- Avinash Rudrapaul
4.00 to 5.00	Tool sharpening, Hardening, Machine maintenance	- M.S.G.Rajan A.K.Das

Day - 2	9.00 to 10.00	Design Translation : Making to size, Drawing, measuring, marking Use of gauges	-	A. G.Rao Sukumar Avinash
	10.00 to 11.30	Introduction to Tool kit/work station, Product Specific tools, Demo. of frame based products + Video		Avinash Rudrapaul A.G. Rao
	11.30 to 1.00	Production Planning, Costing Cost effectiveness by using jigs, fixtures and special tools simple jigs, split jigs	-	A.G. Rao M.S.G.Rajan Avinash
	Lunch			
	2.00 to 3.00	Practice Session on jigs, machines, tool kit		-M.S.G.Rajan Avinash Rudrapaul
	3.00 to 4.00	Product Detailing, combining with other materials, use of different finishes and colours.		-A.G.Rao
	4.00 to 5.00	Finishing with sand paper, Staining with wood stains and lacquering.	-	Avinash
Day - 3	8.00 to 9.00	Visit to IIT Guwahati		
	9.00 to 10.00	Introduction to Bamboo work in the Design Department	-	A.K.Das S.Nadkarni
	10.00 to 11.00	Spray Painting	-	A.K. Das
	11.00 to 1.00	Spray Painting - Practice session		-A.K. Das M.S.Sajuman
	Lunch			
	2.00 to 3.00	Back to C.B.T.C.		
	3.00 to 4.00	Discussion on tool kit, Needs of crafts persons		A.G. Rao Kamesh Salam
	4.00 to 5.00	Feed back session	-	IDC team Kamesh Salam Absar Hazarika S. Nadkarni

Craft persons:

1. Mr. Manish Kumar Jain,
Pragjyotika Enterprises,
Chhabra Bhawan,
M.S. Road, Rly. Gate No. 4,
Fancy Bazar,
Guwahati-781 001.
Dist. Kamrup, Assam.
2. Mr. Niranjan Chakraborty,
C/o. Satyandra Chakraborty,
P.O. South Chorilam (Karamura),
Tripura (West).
3. Shri Dusu Chatung,
C/o.A.D.T.H. Industrial Estate,
Naharagum Arunachal Pradesh,
Dist. Papum Pare,
P.O. Naharlagum,
Pin:791 110.
4. Shri Mimar Sora,
C/o.A.D.T.H. Naharlagum,
Dist. Papum Pare,
Arunachal Pradesh,
P.O. Naharlagum,
Pin:791 110.
5. Mr. Biraj Shama,
Bajer GHO,
Vill + P.O. Dedar GHO,
P/S Gurimuri,
Dist. Sunip Par Assam.
6. Mr. Sudhir Mujumder,
C/o.Surendra Ch. Majumder,
P.O. + Vill - East Malchar,
P/S Melaghar,
Dist. Tripura (West), Pin:799 115.
7. Craftperson (name not noted)
 8. Mr. Mitum Kanta Singh,
Pastoi part (I), N.C. Road,
Imphal Manipur - B.P.O. Pastoi,
P.O. Langjing.
 9. Shri Meisnam Tambi Singh,
Pastoi Part (III), N.C. Road,
B.P.O. Pastoi,
P.O. Langjing,
Imphal (West),
Manipur-795 113.
 10. Mr. Moirangthem Tondon Singh,
Laribal Sabal Liekai,
S.P.O. Lamsang Bazar,
Pin:795 146
Manipur.
 11. Meghalaya 3 participants
 - i. Dhomsing Paniang,
Umling,
BPO Umling,
P.O. Nangpols,
Rikhoi Dist., Meghalaya
 - (ii) Brol Kynter,
C/o. MHHDC Ltd.,
'Lasrat'
Upland Road,
Last Umkhrols,
Shillong - 793 802.
Ph: 225 776.
 - (iii) Marja Kynter,
'Roiang'
Vocational Training Centre for the Disables,
St. Edward's School,
Shillong - 793 002.
Ph: 228 471.

Craft Instructors

1. Mr. M.C.Das,
R.D.T.D.C.,
C/o. DC (H),
Housepad Building,
Baltala Road,
Guwahati - 6.
2. Shri A.K. Raha,
E.C.D.I.,
Agartala - 799 066.
3. Shri Rajesh Kalila,
Instructor,
R.D.T.D.C.,
Beltola Bashista Road,
Guwahati - 781 028.
4. Shri Santi Ram Sharma,
Handi Craft Project,
Assam Govt. Marketing Corpm. Ltd.,
Nalbari (Assam).
5. Mr. Rameshwar Das,
C.F.C. NEHHDC Ltd.,
Gurchur, Guwahati-35.
6. Mr. S. Jayanta Singh,
Asst. Instructor D.T.C. (Bamboo),
N.E.R.O.,
Guwahati.
(Present Address)

Langthabal Mantrikhong,
Awang Hikai - 795 003,
Imphal - Manipur.
(Permanent Address)

7. Mr. Makan Das,
B.C.D.I.,
Agartala.
8. Mr. Shaja M.S.,
IIT-G, Guwahati.

Entrepreneurs

1. Mr. Bimalguri,
Hindustan General Stores,
Garali,
Jorhat - 785 001.
Tel: 320321; 323 531.
2. Mr. Satinder Singh,
Sigma Cane Décor,
K.K. Path, Jorhat,
Ph: 323 297 / 328 080.
3. Mr. Pranjal Bhattacharya,
Nature Craft, C/o. Nutria,
Near City Heart Nursing Home,
Rajgarh Road,
Guwahati - 781 005.
Tel. 0361-552664 (R),
E-mail: Pranjalb@usa.net
4. Shrinanti Dutta,
Home Makers,
Basistha Road,
Beltola,
Guwahati - 781 028.

5. Shri Manendra Deka,
DELA - Cane and Bamboo,
Vill. Metrakuchi,
P.O. Santinagar,
Dist. Barpeta (Assam.)
6. Mr. Satyajit Barua,
C/o.S.K. Das,
Dhupguri, Balabitha,
Barpeta Road, Dist. Barpeta,
Assam (Ph.03666-62816)
(Permanent Address)

Mr. Satyajit Barua,
C/o. Mr. U.N. Sharma,
Guwahati - 781 009.
Ph: 0361 - 511 740
(Present Address)

Govt. Officers:

1. Mr. Pariyat,
Director, M.H.H.D.C.,
Shillong.
2. Mr. Lalhuma-IAS,
M.D., NEHHDC,
Shillong.
3. Mr. Hatzaw,
Regional Director,
DD(H)'s Office.

Workshop at Nagaland

List of registered candidates for attending workshop in cane & bamboo

Sl.No.	Name and Address	District
1.	Shri Ghdhevi C/o Dist. Manager, NHHDC Zunhaboto	Zunhaboto
2.	Shri Huvito Sena - as above-	do - -
3.	Shri Tia Ao Mopongchukot (Mkg) C/o Dist. Manager, NHHDC Mokokchung.	Mokokchung
4.	Shri Apong Ao - as above-	do - -
5.	Shri Tiamangalang Phem CDC, NHHDC, Mangkolemba	- do -
6.	Shri Kihoylo Sama C/o CDC, Mangkolemba.	-do-
7.	Shri P.Threbse Chang Yimpang Village, C/o Dit. Manager, NHHDC Tuensang.	Tuensang
8.	Shri T.Chaangsimen-do- Chingmei Village, C/o Dist. Manager, NHHDC Tuensang.	-do-

9.	Shri Tahyim Konyak Tangnyu Village, C/o Dist.Manager, NHHDC Mon .	Mon ,
10.	Shri Tingham Konyak - Shingnha Chingnyu, C/o. Dist. Manager, NHHDC Mon .	Man
11.	Shri Zakiekedo Angami Mechanised Furniture & Handicraft Unit, Chumukedima.	Dimapur
12.	Shri Zuben Lotha Naga Exotic Society, 4th Mile, Dimapur.	-do-
13.	Shri Zacitse Sapu Diezegehe Village	-do-
14.	Shri Nirmal Exclusive Cane, Dimapur	-do-
15.	Shri Yetsaperno Lotha C/o. Dist. Manager, NHHDC Wokha .	Wokha
16.	Shri Zupenthung Lotha C/o. Dist. Manager, NHHDC Wokha .	Wokha
17.	Shri Ponkgu Khiarniungan C/o CDC NHHDC Dimapur .	Dimapur
18.	Shri Phudau Phom as above	- do -
19.	Shri Longdang Phom as above	- do -

20.	Shri P. Thungo Yanthan Bethesda Youth Welfare Centre, 194 Duncan Bosti, P.B.No.33, Dimapur.	Dimapur
-----	--	---------

Unregistered Candidates

1.	Shri Alem Longkumer Country Craft, 7th Mile, Chumukedima.	Dimapur
2.	Shri ImLongghaba Chang Pioneer Handicraft Unit, Walford, Dimapur.	-do-
3.	Shri Huveta Tetsee C/o. Manager, NHHDC Kohima .	Kohima
4.	Shri Nuvoto as above	Kohima
5.	Shri Vikheto Yeptho Dimapur	Dimapur
6.	Hetoi Yeptho	
7.	Rokovikho Tsiepara Village, Kohima Dist.	Kohima
8.	Jongshimeren Dimapur	Dimapur

**3-day Workshop at Nalchar
(20th, 21st & 22nd September, 02)**

List of Participants:

1.Sri Sajal Das,
S/o Nepal Das, East Nalchar.

2Sri Bimal Sukladas,
S/o Lalmoan Sukladas,
East Nalchar.

3.Smt.Jadish Das,
W/o Subah Nama,
East Nalchar.

4.Sri Jagadish Das,
S/o Late Surendra Das,
East Nalchar.

5Sri Ranjit Das,
S/o Debendra Das,
East Nalchar.

6.Smt. Marani Das,
W/o Ashu Das,
East Nalchar.

7.Smt. Putul Nama,
W/o Satish Nama, East Nalchar.

8.Sri Mahendra Nama,
S/o Debendra Nama, West Nalchar.

9.Sri Anil Debnath,
S/o Late Akshoy Debnath, East Nalchar.

10.Sri Sukhen Debnath,
S/o Narendra Kp.Debnath, East Nalchar

11.Sri Adwaitya Debnath,
S/o Late Chandrasagar, East Nalchar.

12.Sri Goranga Sarkar,S/o Lalmoan Sarkar,
West Nalchar.

13.Sri Sachindra Debnath,
S/o Late Pran Ballo Debnath, East Nalchar.

14.Sri Manindra NamaS/o Late Ramani Nama,
East Nalchar.

15.Smt. Kajal Nama,
W/o Kalachand Nama, West Nalchar.

16.Sri Swadesh Nama,
S/o Late Ramesh Nama, West Nalchar.

17.Sri Ranjit Nama,
S/o Late Rakhal Ch. Nama, West Nalchar.

18.Sri Pratip Nama,
S/o Late Harendra Nama, West Nalchar.

19.Sri Sumangal Ch.Sukladas,
S/o Harendra Ch. Sukladas, Bangabasa.

**2-day workshop at B.C.D.I. , Agartala
on 18th & 19th September, 2002**

List of Craft persons/Officials
who participated in the workshop:

Name & address of craftsmen

1.Shri Samir Ghosh, S/o. Shri Sadhan Ch. Ghosh, Vill. & PO Indranagar, Agartala, Tripura (W) .	8.Smt. Kajal Rani Das, W/o Sri Pulin Behari Das, Vill. & PO Charilam, Tripura (W) .	18.Sri Manoj Kr. Debnath, S/o Lt. Atul Ch. Debnath, Vill.&PO Bagabasha, Tripura (w) .
2.Smt. Rinku Deb, D/o Shri Bimal Ch. Deb, Vill. & PO Indranagar, Agartala, Tripura (W) .	9.Shri Sukesh Ch. Paul, S/o. Lt. Haridas Paul, Town Pratappgarh, Agartala, Tripura (W) .	19.Smt. Nitya Rani Debnath, W/o Monmohan Debnath, Vill. & PO Charilam, Tripura (W) .
3.Smt. Jyotsna Das (Mazumdar), Vill. & PO Indranagar, Agartala, Tripura (W) .	10.Shri Gopal Sutradhar, Banamalipur, Agartala, Tripura (W) .	20.Sri Goutam Das, S/o Sri Gouranga Das, Vill.&PO Jogentranagar, Agartala, Tripura (W) .
4.Smt. Nandita Chakraborty, Vill. & PO Indranagar, Agartala, Tripura (W) .	11.Smt. Banu Nama, W/o. Sri Madan Nama, Vill. & PO South Charilam, Tripura (W) .	21.Sri Krishnadas Paul, Master, Para, Agartala, Tripura (W) .
5.Shri Manik Nama, S/o Sri Sadhan Nama, Vill. & PO South Charilam, Tripura (W) .	12.Smt. Parul Nama, W/o Sri Monmohan Nama, Vill. & PO South Charilam, Tripura (W) .	22.Sri Ranu Ch. Das, S/o Lt.Bholanath Das, Vill. Milansangha, PO A.D.Nagar, Agartala, Tripura (W) .
6.Sri Prasanta Mahali, S/o Sri Kamal Mahali, Vill. & PO Indranagar, Agartala, Tripura (W) .	13.Sri Anath Bandhu Sutradhar, M/s. Daru Shilpalaya, Town Pratappgarh, Agartala, Tripura (W) .	23.Smt. Amita Debnath, D/o Sri Sukhlal Debnath Jogendranagar, Agartala, Tripura (W) .
7.Sri Dipak Das, S/o Sri Dinesh Ch. Das, Vill. & PO Indranagar, Agartala, Tripura (W) .	14.Smt. Sandhya Sutradhar, W/o Sri Sadhan Sutradhar, Vill. & PO Indranagar, Agartala, Tripura (W) .	24.Sri Dilip Nama,32. O/o the DC(H), Agartala. Sri Dilip Nama, S/o Sri Manindra Nama, Jogendranagar, Agartala, Tripura (W) .
	15.Smt. Sadhana Sarkar, W/o Tapan Sarkar Dhaleswar, Agartala, Tripura (W) .	25.Smt. Bhanu Nama, D/o Sachindra Nama, Jogendranagar, Agartala, Tripura (W) .
	16.Sri Monoranjan Debbarma, S/o Padma Mohan Debbarma, Vill. Duigaria, P.O. Uttar Desh Garia, Tripura (W) .	26.Sri Partha Sarathi Dutta, C/o Ramesh Chaudhuri Racha Kishorepur, Tripura (W) .
	17.Sri Sankar Rudrapaul, S/o Sri Raj Kumar Rudrapaul, Vill. & PO Nandan Nagar, Agartala, Tripura (W)	

**Participants from B.C.D.I. & M.S.E.C. ,
Agartala:**

27. Shri S.R. Masram,
Officer-in-charge, BCDI, O/o the DC (H) ,
Khejurbagan, Kunjaban, Agartala.
28. Shri A.K. Raha,
Tech. Supervisor, BCDI, O/o the DC (H) , Agartala.
29. Shri Makhan Ch. Das,
Master Craftsman, BCDI, O/o the DC (H) , Agartala.
30. Shri Rabindra Debnath,
BCDI, O/o the DC (H) , Agartala.
31. Smt. Sachi Karmakar,
Instructor, BCDI, O/o the DC (H) , Agartala.
32. Smt. Bina Debnath, Instructor, BCDI,
O/o the DC (H) , Agartala.
33. Shri A.K. Das,
Investigator, M&SEC, O/o the DC (H) , Agartala.

Workshop at IDC

List of Participants from Bangalore & Nagaland

- :
1. Mr. B.P. Ramachandra,
R.T.D.C., 32, Victoria Road,
Bangalore - 560 047.
2. Mr. Puttaswamachar,
R.T.D.C., 32, Victoria Road,
Bangalore - 560 047.
3. Mr. Alem Longkumer,
Country Craft, 7th Mile,
Chomukedmir, Dimapur,
Nagaland.
4. Mr. Ase Chuzho,
Diezhheche Craft Society,
Dimapur, Nagaland.
5. Mr. Z. Sapu,
Diezhheche Craft Society,
Dimapur, Nagaland.
6. Mr. Arun C. Das,
Post & village Narchar (E) ,
O/o.DC (H) , Tripura.
7. Mr. Dilip Das,
Post & Vill. Nalchar (E) ,
Police Station Melaghar,
Tripura (W) .
8. Mr. Zuben Lotha,
Naga Exotic Society, 4th Mile,
Dimapur, Nagaland.

**7-day workshop held at IDC, IIT-B from 3 - 9th
September, 2002**

Participants from Nagaland & Barapeta:

1. Mr. T. Yanger Sor,
P.O. No.13,
Mokokchung, Nagaland.
2. Mr. S.P. Purch,
Diezhheche village,
Dimapur, Nagaland.
3. Mr. Vepfuto,
Diezhheche village,
Dimapur, Nagaland.
4. Mr. Kaidinpilak,
Samzuriram village,
Jalukie, Nagaland.
5. Mr. Mehbool Hussein,
Saptashree Handicrafts,
Barapeta.
6. Mr. Samad Ali,
Saptashree Handicrafts,
Barapeta.