

**DESIGN OF COOKWARE  
FOR RESIDENTIAL RICE COOKING APPLICATION  
USING STEAM FROM SOLAR STEAM GENERATOR**

**INDUSTRIAL DESIGN PROJECT III  
MDP - 447**

**BY  
GAURAV VAIDYA  
146130002**

**GUIDE: PROF. B K CHAKRAVARTHY  
CO-GUIDE: PROF. MILIND RANE**



**INDUSTRIAL DESIGN CENTRE  
INDIAN INSTITUTE OF TECHNOLOGY BOMBAY  
2016**

Design of Cookware  
for Residential Rice Cooking application  
using steam from Solar Steam Generator

Design Project III Report  
Dec 2015 - April 2016

•••

Guided by : Prof. B K Chakravarthy  
Co-guide : Prof. Milind Rane

Gaurav Vaidya | 146130002 | Product Design



“May we attain that excellent glory of Sun the God: So May he stimulate our prayers.”  
–Gayatri Mantra

# Approval

---

Industrial Design Project III

"Design of Cookware for residential Rice Cooking application using Steam from Solar Steam Generator "

By: Gaurav Vaidya

M. Des in Industrial Design

2014-2016

Is approved as a partial fulfilment of requirements of a post graduate degree in Industrial Design at IDC, IIT-Bombay.



External Examiner



Internal Examiner

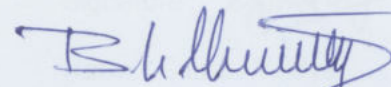

Project Guide

29/6/16

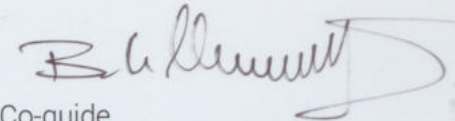

Co-guide



Chairperson

...

# Declaration

---

I declare that this written submission represents my idea in my own words and where other ideas or words have been included, I have adequately selected and referred the original source.

I also declare that I have adhered to all principles of academic honesty and integrity and have not misinterpreted or fabricated or falsified any ideas / data / facts / sources in my submission.

I understand that any violation of the above will be cause for disciplinary action by the Institute and can also evoke penal action from the sources that have not been properly cited, or from whom proper permission has not been sought.

Signature: 

Name : Gaurav Vaidya

Roll No : 146130002

Date : 18.04.2016

...

# Acknowledgements

---

Thank you to Prof. B K Chakravarthy for his valuable guidance and extreme patience. A humble thanks to Prof. Sandesh, Prof. Bapat, Prof. Kumaresan for their guidance and feedback during the process.

I would like to thank Prof. Milind V Rane, Heat Pump Lab, IIT B for giving me valuable insights and guidance.

I would like to extend my thanks to Tata Centre at IIT Bombay for the help and support I received.

My batch mates at IDC and my parents who have been the greatest resource at the best and worst of times.

# Abstract

---

Solar energy is clean and abundant source of energy. This energy is utilized for many applications and cooking is one of them. There are various types of solar cookers available in the market, but they are not that efficient. Each one has its pros and cons.

For using currently available solar cookers, users need to have open space where they will get ample amount of continuous sunlight, the users need to track the sun all day, the whole process of cooking takes place outside kitchen and it is very slow and cumbersome process.

This project is an attempt to make the whole cooking activity quick, easy and inside kitchen while using steam generated from solar energy for a single

home usage. The affordable steam generation technology developed by Heat Pump Lab, Mechanical Department (IITB) is adopted while the product which is using this steam is designed during this project.

The 7Cs of innovation as guided by Prof. B K Chakravarthy was the design methodology adopted for the project. This report outlines the detailed design process followed during the project.

...

# Contents

---

Approval . . . . .	i
Declaration . . . . .	ii
Acknowledgements . . . . .	iii
Abstract . . . . .	iv
Contents . . . . .	v
1. Introduction . . . . .	1
2. The Cause . . . . .	2
2.1 The unsustainability of fossil fuel use in India	
2.2 Solar Power in India	
2.3 LPG Price Rise	
3. The Context . . . . .	3
3.1 Market Study	
3.2 Other Cooking Methods	
3.3 Comparison between Traditional/ Modern cooking and Solar cooking	
3.4 Simple and Affordable Steam Generator developed by Heat Pump Lab	
3.5 User Study	

4. The Comprehension .....	11	6.8 Understanding Existing Kitchen Appliances	
4.1 Insights from User Study		6.9 Keywords and Mood Board	
4.2 Issues with the current vessel		6.10 Handle on Food Container	
5. The Check .....	13	6.11 Steam Inlet Valve	
5.1 Design Brief		6.12 Regulator / Control Knobs of Home Appliances	
5.2 Design Considerations		6.13 Finger Grip on the Knob	
5.3 Scope of the Project		6.14 Position of Control Knob on Cookware	
5.4 Target User		6.15 Direct Analogy	
5.5 Usage Scenarios		6.16 Water Drain Valve	
6. The Conception .....	15	6.17 Locking Mechanism	
6.1 Direct Heat Transfer		6.18 Form Explorations	
6.2 Indirect Heat Transfer		7. The Crafting .....	77
6.3 Concept Validation		8. The Connection .....	82
6.4 Calculations		8.1 Position and Location of the product inside kitchen	
6.5 Final Concept		9. Key Finding .....	86
6.6 Product, User & Environment		10. References .....	87
6.7 Position of Product Inside Kitchen			

# 1 Introduction

---

Solar energy is an important part of life and has been since the beginning of time. Increasingly, man is learning how to harness this important resource and use it to replace traditional energy sources.

It is considered a clean energy source. In the future, solar energy may well be the primary form of energy. It has the potential to allow technology and nature to co-exist peacefully.

Currently solar power is being used for heating, lighting, cooking etc. But the penetration of use of solar powered products is restricted due to certain limitations such as high initial cost, solar efficiency concerns and convenience

in use. The project started with the idea to design consumer/lifestyle products which will encourage homeowners to use solar powered products.

During a series of discussions with guide and co-guide the project focus was narrowed down on harnessing the energy of the sun for one of man's basic need – food.

...

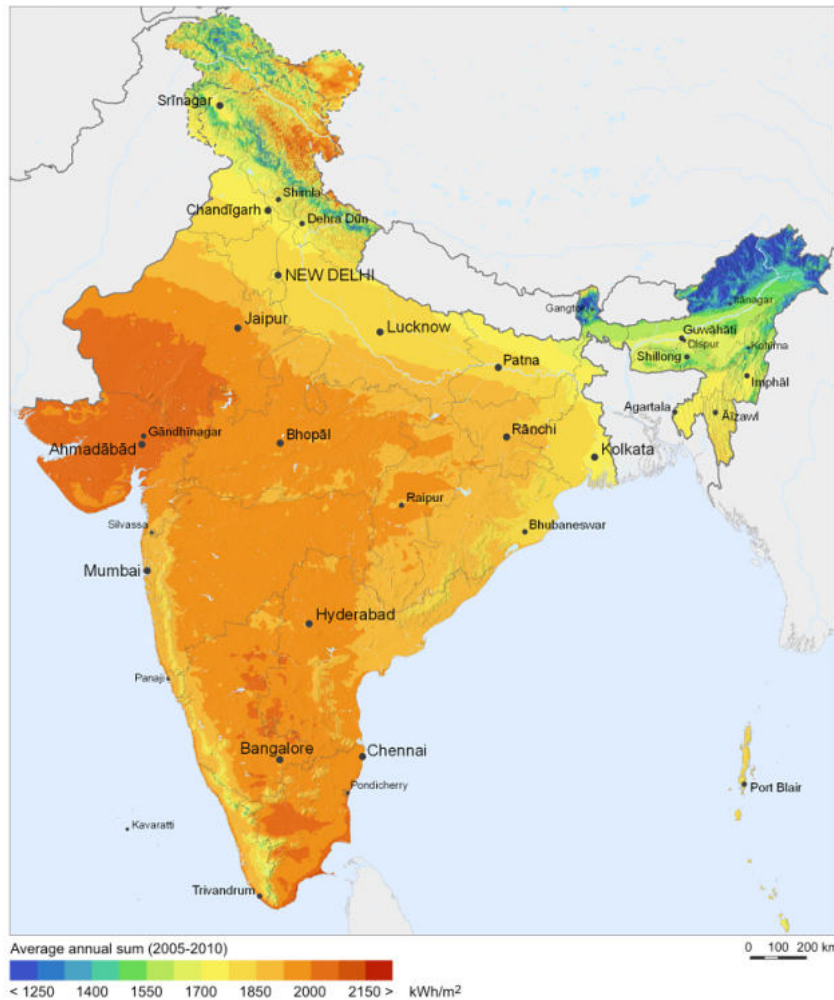

"Solar Resource Map of India" by SolarGIS © 2011

## 2 The Cause

### 2.1 The unsustainability of fossil fuel use in India

The high dependence of India's energy system on fossil fuel is unsustainable not only because of the high share of carbon footprint in the total ecological footprint and the various other adverse environmental effects, but also because of the economic unsustainability of such dependence due to heavy financial requirement for imports arising from the growing scarcity of the fossil fuel resources.[1]

### 2.2 Solar Power in India

With about 300 clear, sunny days in a year, India's theoretically calculated solar energy incidence on its land area alone, is about 5,000 trillion kilowatt-hours (kWh)

per year. The solar energy available in a year exceeds the possible energy output of all fossil fuel energy reserves in India.[2]

### 2.3 LPG Price Rise

There is increase in price of LPG cylinder almost in every two months. Also the Indian Government has scrapped subsidy on LPG for users who have taxable income over 10 lakh. Undoubtedly, there will be no alternative to use sustainable fuel for cooking.

...

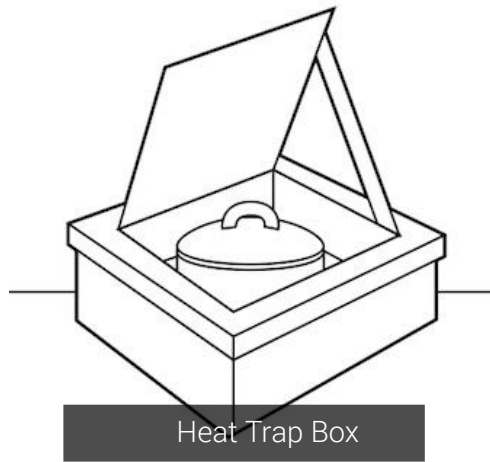

Heat Trap Box

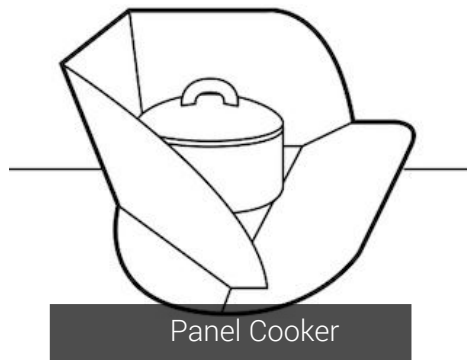

Panel Cooker

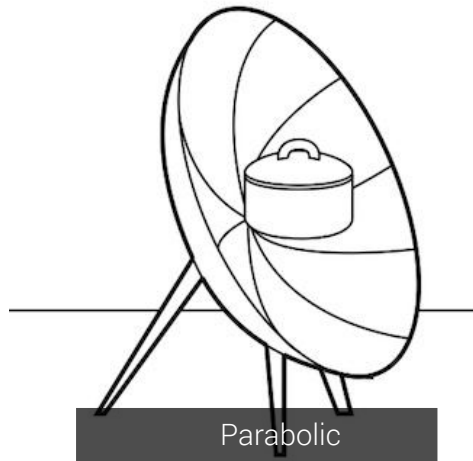

Parabolic

## 3 The Context

### 3.1 Market Study

Mainly there are three types of solar cookers and they are heat trap boxes, curved concentrators (parabolic) and panel cookers.

#### 1. Heat Trap Box Type

It works on the black body principle. In this, the food is placed inside of an insulated box for purposes of retaining or trapping the solar rays that get converted to heat energy. The inside surfaces and containers are painted black to absorb maximum energy.

#### 2. Panel cookers

Panel cookers have a flat panel which reflects and focuses sunlight for cooking and heating. The

panel cooker is quite similar in operation to the solar box cooker. The same principles are employed but instead of an insulated box, panel cookers typically rely on a large multifaceted reflective panel.

#### 3. Curved concentrators (parabolic) Type

The parabolic type of solar cooker comprises of reflective metal sheets joined together to form an umbrella sort of shape. When the sun rays fall on the metal sheets the energy is concentrated into a small area, where the cooking vessel is placed. The parabolic cooker can reach high temperatures more quickly, therefore cooking is accomplished more rapidly. It needs more precision

to focus the sunlight on the food in the pan. If the sunlight is not correctly focused on the food in the pan, the food will not be cooked well.

#### **Advantages**

1. Simple and safest way of cooking food
2. Low tech and low maintenance
3. Even cooking
4. Do not heat up the kitchen

#### **Disadvantages**

1. Slow process
2. Open space with ample sunlight is required
3. Solar tracking or frequent alignment is necessary
4. Early preparation needs to be done
5. Each time food items need to be carried out to balcony or terrace

#### **4. Steam Solar Cooking**

In this, parabolic reflectors are used to heat water or oil having low boiling temperature. This high temperature steam or oil is passed through pipes to a cooking

vessel where the heat is transferred to the food in the jacket vessel.

#### **Advantages**

1. Effective and useful for large scale cooking

#### **Disadvantages**

1. Requires solar tracking
2. Requires lot of space
3. Weight of total system is high
4. Other accessories like fluid circulating pump, pipe fitting, insulation, controls etc are required which increase cost

This type of cooking system is installed at Auroville (Pondicherry), Shirdi Sansthan (Maharashtra), Mount Abu (Rajasthan).

There are several other types of solar cookers which are based on one of the above methods to cook food. There are flat plate collectors which do not generate steam. Evacuated glass tubes type collectors are used for heating water but they are not efficient in steam generation.



Auroville Solar Bowl



Solar Collectors at Shirdi



Boiling



Pressure Cooker

Traditional Cooking Methods



Electric Cooker



Microwave



Induction Cooker

Modern Cooking Methods

3.2 Other Cooking Methods

For cooking, there are various methods followed.

1. Boiling
2. Pressure Cooker
3. Induction Cooking
4. Electric Cooker
5. Microwave oven cooking

Cooking by these methods is easy, instant and it happens inside the kitchen. These methods are used instead of solar cooking because of convenience. But in this, unsustainable fuels like LPG or electrical energy are used.

3.3 Comparison between Traditional/ Modern cooking and Solar cooking

Traditional / Modern Cooking

Easy  
Quick  
Inside Kitchen

Use of LPG / Electricity

Solar Cooking

Takes long time  
Cumbersome  
Open space required  
Outside Kitchen

Use of Solar Power

A product which makes cooking easy, quick, operates inside kitchen and works on solar power does not exist in market.

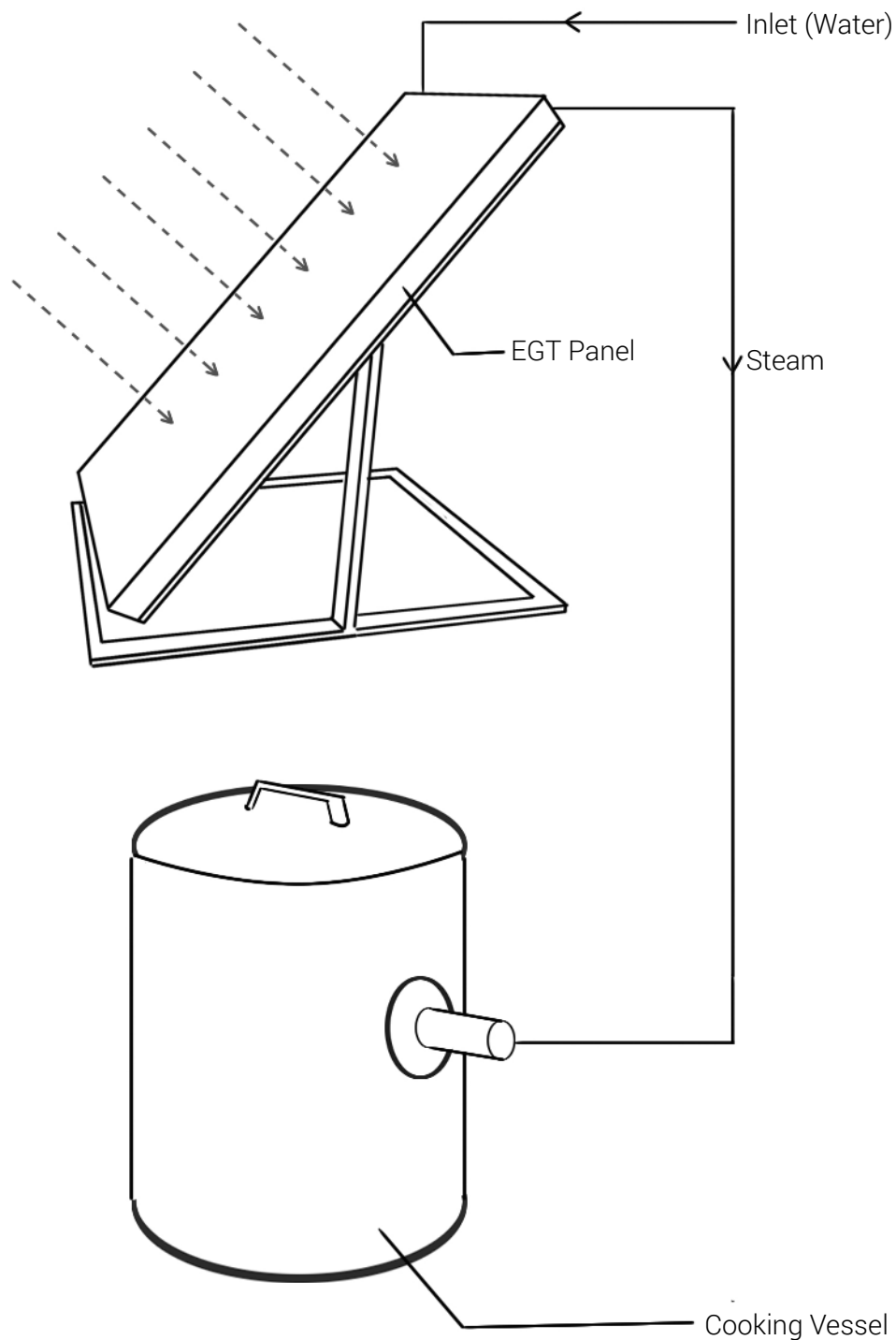

### 3.4 Simple and Affordable Steam Generator developed by Heat Pump Lab (Mechanical IITB)

Heat Pump lab at IIT Bombay has developed a steam generator which uses evacuated glass tubes deployed with multi-wall polycarbonate top cover and multi layer rigid foam back insulation. It has enhanced efficiency due to reduction in heat losses.

The inner glass tubes are filled with heat storage medium to store the collected heat. A copper tube coil with aluminium foil fin is deployed in the storage medium to enable extraction of heat as and when needed. Heat loss from the bottom side is reduced using a multilayer rigid foam insulation under the EGT and reflectors.[3]

Durability is enhanced and maintainability is improved due to the enclosed reflectors. Storage medium

temperature of 200 to 300°C are achieved with this design. Preliminary experimental data reveals that such collectors can be used to generate steam at 1 to 10 bar using the low cost seasonally tracked low profile collectors.[3]

The steam generated by this unit is currently being tested to cook food. The cooking vessel used is standard pressure vessel used for industrial applications.

After initial data collection, it is found that solar steam based cooking is practiced for preparing food on large quantity in places like hotels, temples etc. There is no such low cost solar steam generation unit available which can be used for domestic cooking (for a single household).

The idea is to use this solar steam generator for domestic cooking application.

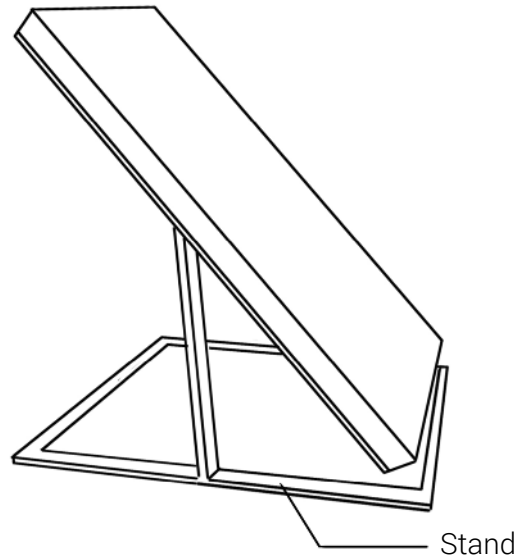

In order to work on the domestic application of solar steam generation, first it becomes necessary to understand the steam generation system and its components. Understanding of the system got better through multiple visits to heat pump lab (mech IITB) .

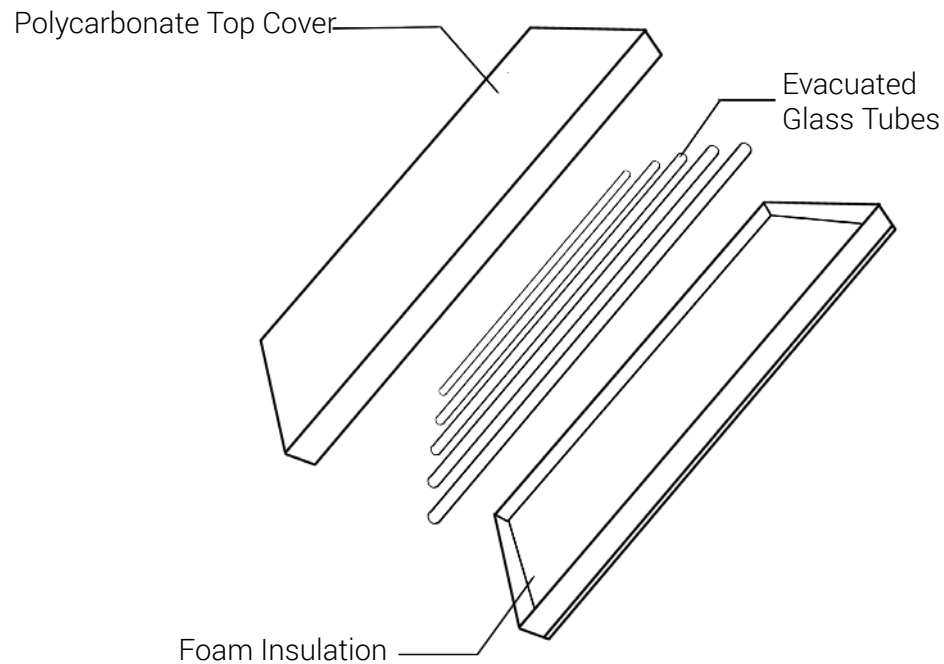

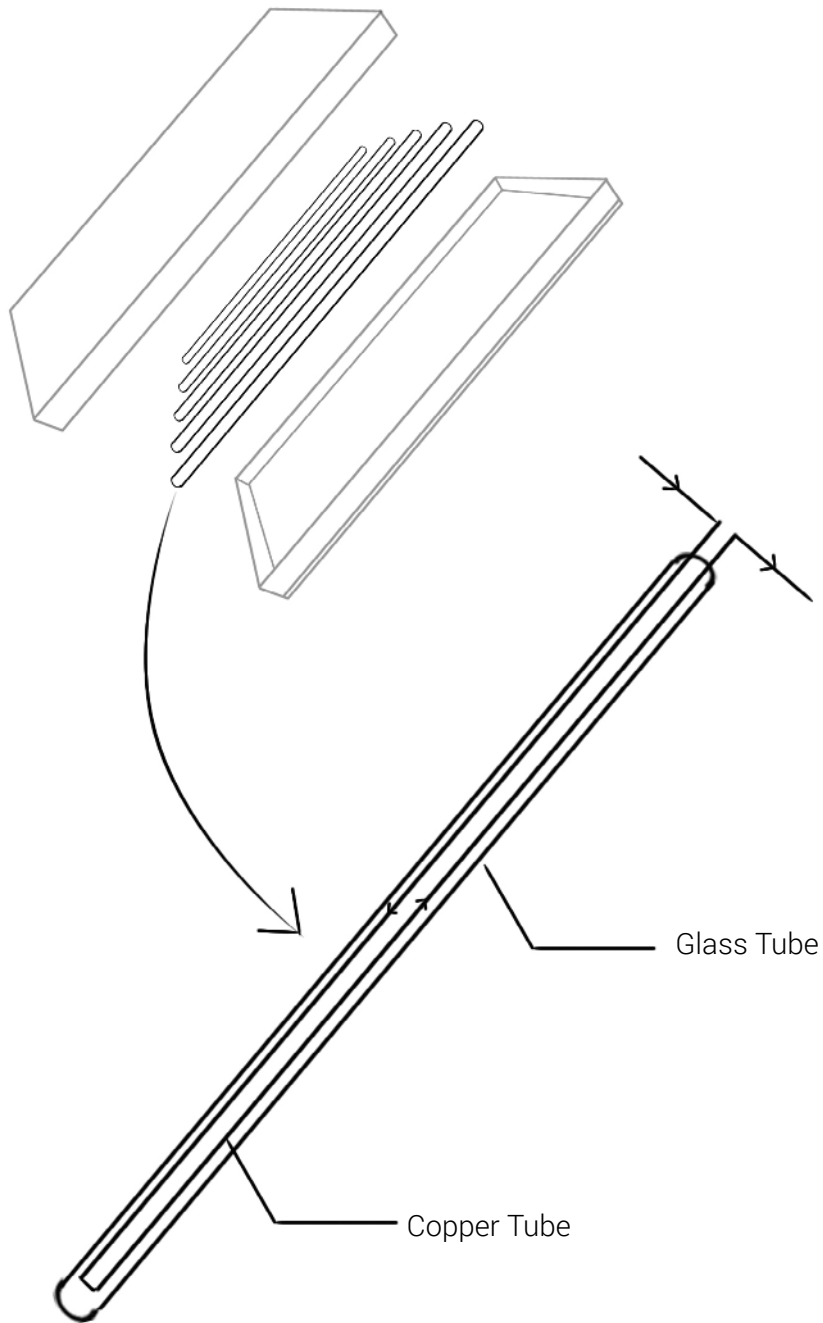

Evacuated Glass Tube details

Collector performance in the month of December 2015 in Mumbai

Time			Temp
From	Mean	To	°C
9.00	9.15	9.30	50
9.30	9.45	10.00	63
10.00	10.15	10.30	76
10.30	10.45	11.00	90
11.00	11.15	11.30	105
11.30	11.45	12.00	114
12.00	12.15	12.30	123
12.30	12.45	13.00	131
13.00	13.15	13.30	144
13.30	13.45	14.00	157
14.00	14.15	14.30	159
14.30	14.45	15.00	161
15.00	15.15	15.30	149
15.30	15.45	16.00	144
16.00	16.15	16.30	140

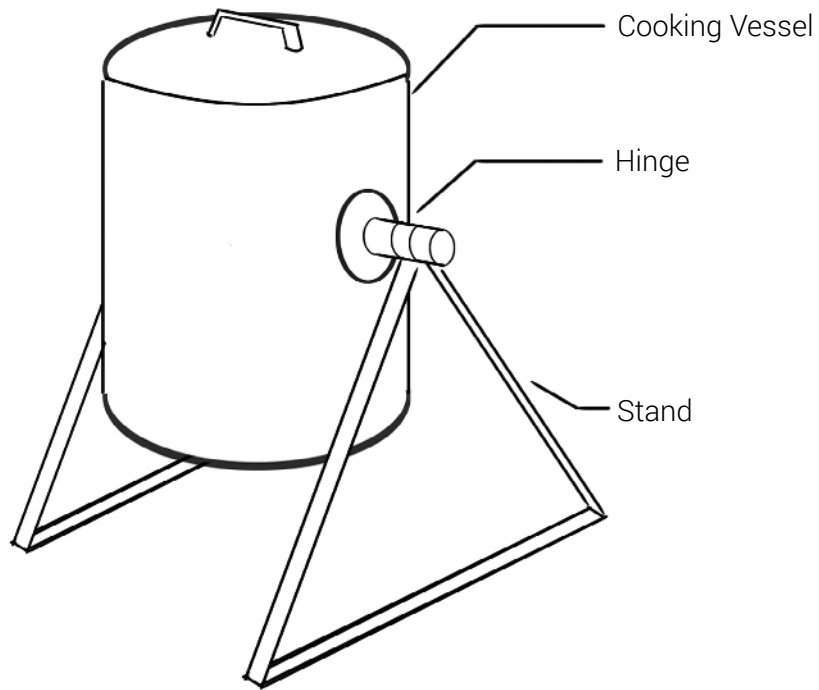

Advantages of Solar Steam Generator developed by HPL IIT B

1. Simple and affordable
2. Seasonally tracked, once in 15 day if desired
3. Enhanced efficiency by reducing heat losses
4. Water supplied from an overhead water tank or tap is converted to steam in a single pass

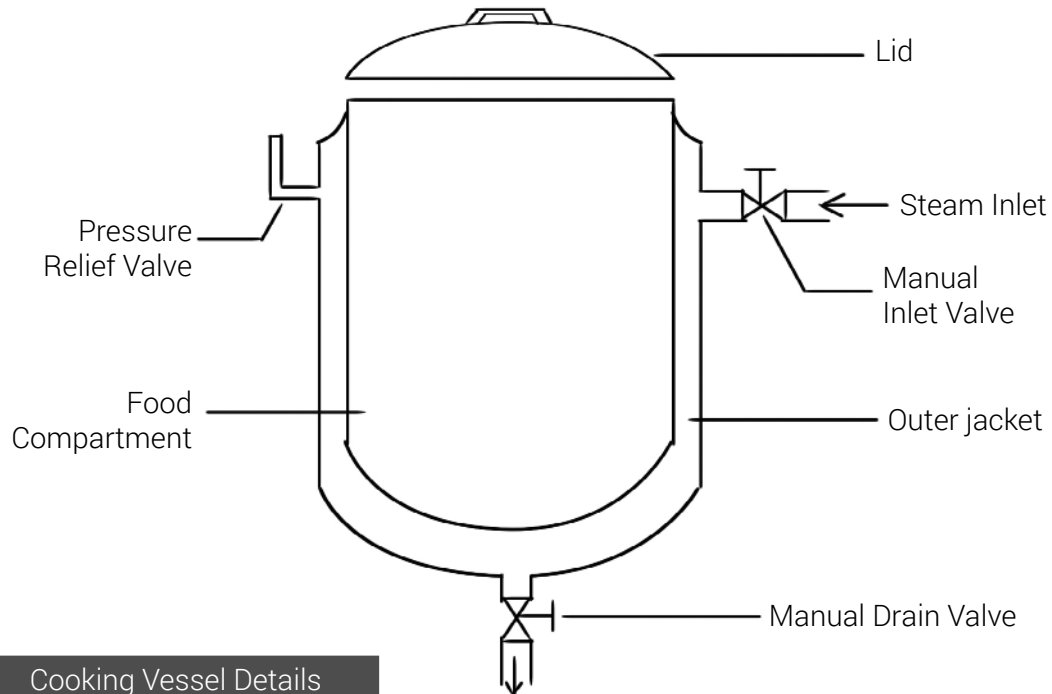

Cooking Vessel Details

Sr. No	Name	Family Members	Food Cooked in Pressure Cooker	Cooker Capacity (lit)	Usage (No. of times/day)
1	Tushar	4	Rice, Dal	6.5 5	1
2	Joshi	5	Dal , Curry	8	1
3	Bharti	3	Rice, Idli, Curry, Sambhar	4.5 2	2
4	Bali	4	Rice	4.5	1
5	Vasanti	6	Rice, Dokla, Soup, Chicken	10 7.5	2
6	Saroj	3	Rice, Dal	4.5	1
7	Renu	3	Rice	3	1
8	Sukesh	4	Dal, Curry	8	1
9	Shashank	5	Rice, Dal	5	1
10	Vishal	2	Rice, Dal, Curry	3 1.5	2
11	Patric	2	Rice, Sambhar, Curry	5	2
12	Barwad	4	Dal	5	1
13	Kadukar	6	Rice, Curry	6.5	1
14	Husen	5	Rice, Chicken	4.5	1
15	Roy	3	Curry, Rice, Chicken	3	2
16	Bhise	6	Rice, Dal	5	1
17	Fulzele	4	Curry, Dal, Soup	3	2

### 3.5 User Study

In order to get general idea about food habits, normal cooking practices and type of food cooked daily inside a kitchen, a user study was made. The user group chosen was from urban (city and town) parts of India.

## 4 The Comprehension

---

### 4.1 Insights from User Study

The most common food items in daily Indian lunch/dinner are chapati, paratha, dal, rice, sambhar and curry. Out of these food items, rice and dal are generally prepared in a pressure cooker. Pressure cooker size that is most common is 5 liter capacity and the average family size is 4 family members.

Female members of the house cook food and they prefer to cook it while in standing posture near the kitchen counter top. Gas stove is at the centre and all other things are arranged around it.

The initial user study helped

to a deeper understanding about the cooking habits, which formed basis for design brief.



Existing Cooking Vessel

The cooking vessel currently being tested is jacketed pressure vessel and it uses indirect cooking method. In indirect cooking, the steam does not enter into the food and it remains in the outer jacket of the vessel. Conductive heat transfer takes place to cook the food. The material of the vessel is SS304.

#### 4.2 Issues with the current vessel

1. **Size-** It is designed for large volume cooking
2. **Aesthetics-** It appears like an industrial equipment rather than home appliance
3. **Function-** Many manual operation are involved in order to operate the vessel. Those operations are closing and opening of steam inlet valve and drain valve.
4. **Cleaning-** As the jacket is inaccessible, it is impossible to clean it if scales form on the walls over a period of time.
5. **Material-** Being large in size and made from SS304

the whole vessel is quite heavy.

6. **Ergonomics-** Cooked food is taken out of the vessel by tilting it with the use of handle.

## 5 The Check

---

### 5.1 Design Brief

Design a cooking vessel heated by steam generated from solar steam generator.

- A cooking vessel which is adaptable for home application.

### 5.2 Design Considerations

1. It should effectively use the steam generated by solar steam generator.
2. It should be easy to handle and portable.
3. The aesthetics of new design should maintain aesthetic appeal of a kitchen gadget.
4. It should be easy to clean after every use.
5. It should be mass manufacturable.

people using the steam  
The device is meant to be used once or twice in a day.

Redesign of the solar steam generator is excluded from the scope of this project.

### 5.4 Target User

People living in urban areas who have sufficient space to install collector panels.

### 5.3 Scope of the Project

The device designed will cater to the need of cooking rice for a family of 4 to 6

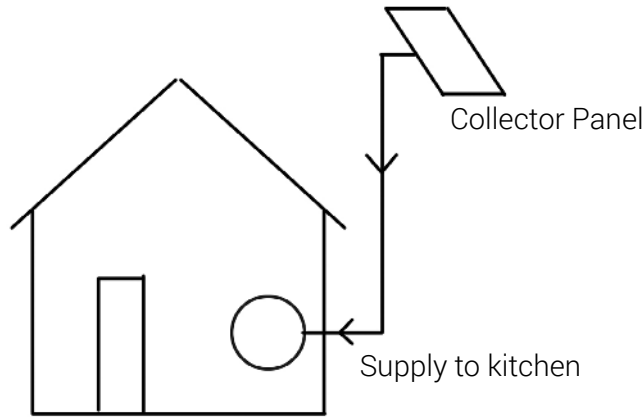

## 5.5 Usage Scenarios

### Scenario 1 - Single house supply

In this, user will have solar collector panels for individual use. The steam generated is supplied into the kitchen through piping. The user can utilize the quantity of steam according to his/her requirements of cooking.

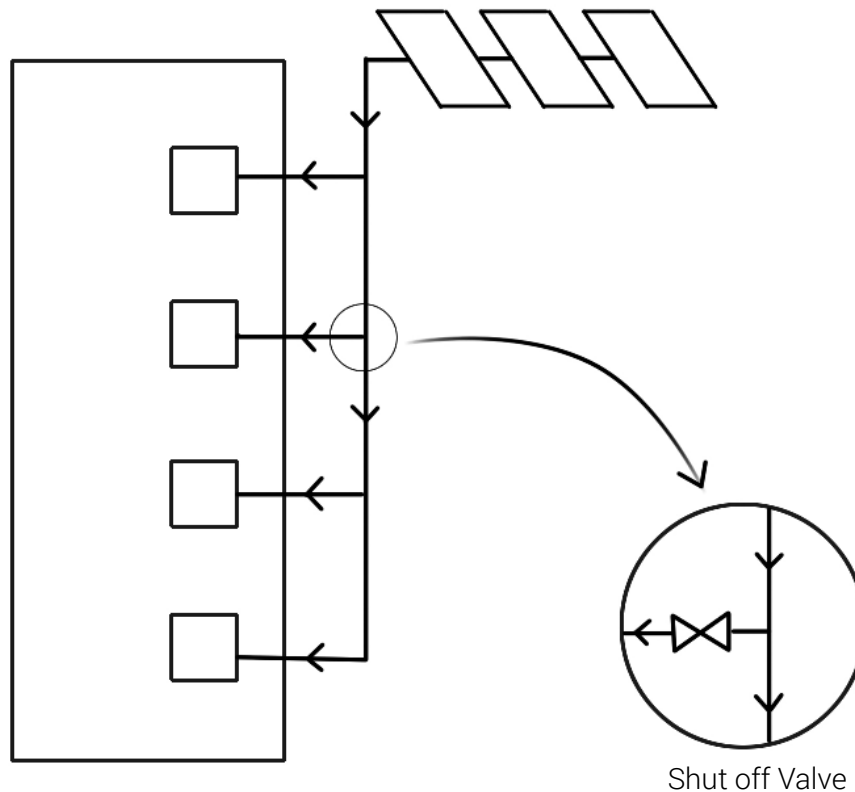

### Scenario 2 - Multiple house supply through common collector panels

In this, multiple houses are supplied the steam in their kitchen through steam piping network. In order to limit the usage of steam, each steam connection is fitted with a steam flow shut off valve. This valve is monitoring the quantity of steam usage and it trips as the usage limit exceeds beyond a calculated amount and the steam line remains shut off for several hours (say 12 hours). This ensures each house gets equal amount of steam per day.

## ⑥ The Conception

---

Based on the analysis done on the existing product study, target user and design brief, ideations were done taking into consideration of various possible creative solutions.

For each idea, a quick paper model is made to get clarity and it also helps in manipulating components as well as the arrangement of components in different ways to generate new ideas.

Ideation started with sketching without ruling out any concept as impossible. Later on, some of the ideas were refined to form a feasible concept.

Ideas are clustered on the basis of mode of steam injection

1. Direct heat transfer  
(steam passage inside food container)

2. Indirect heat transfer  
(keeping steam and food separate)

## 6.1 Direct Heat Transfer

### 1. One Steam inlet at the top portion of food container

In this, steam directly enters the food container through single inlet. The heat of steam is utilized to cook the rice inside the vessel.

As there is a single inlet, the steam may not circulate properly and some portion of rice may remain uncooked.

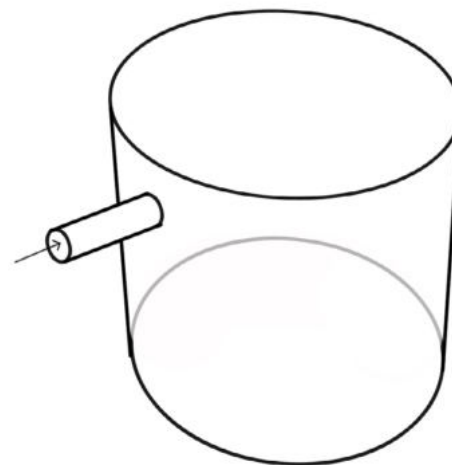
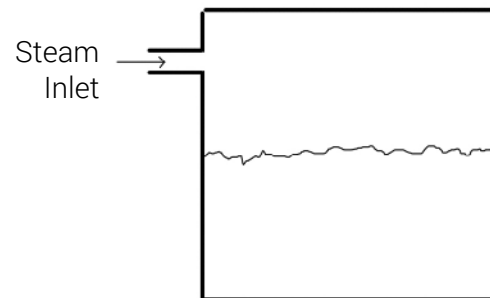

## Direct Heat Transfer

### 2. Multiple Steam inlets

For better circulation of steam and even heat transfer, steam is injected in the rice vessel through multiple inlets.

This involves a complex steam piping network around the vessel.

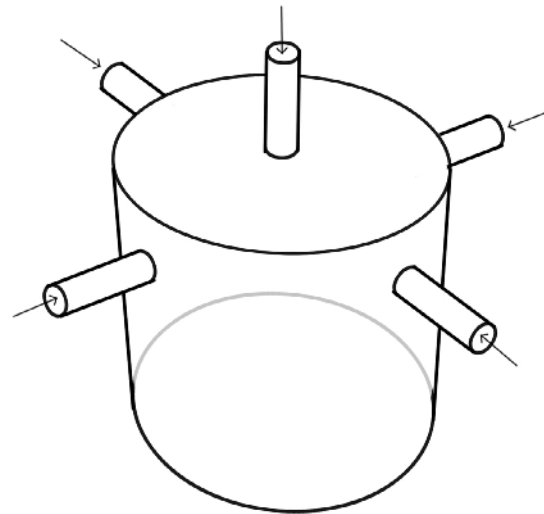
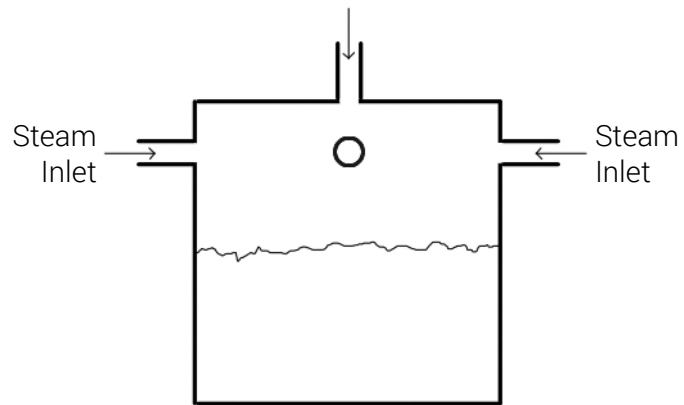

## Direct Heat Transfer

### 3. Steam Distribution Inside Vessel

In order to achieve even distribution of steam inside vessel, a steam pipe with perforations is inserted inside vessel.

The rice is put in small containers arranged one top of another which are similar to idli maker containers.

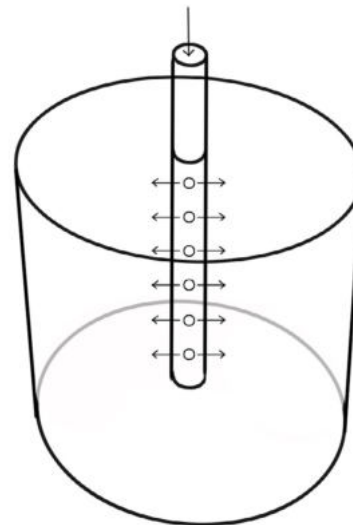
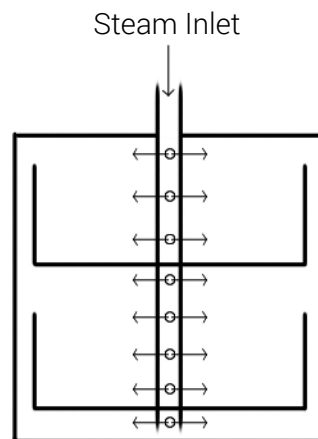

## Direct Heat Transfer

### 4. Perforated Rotating pipe

In this, a perforated rotating pipe distributes the steam inside the vessel. It works on the same principle as that of a water sprinkler.

As it involves moving parts, it may require maintenance and may be subjected to failure.

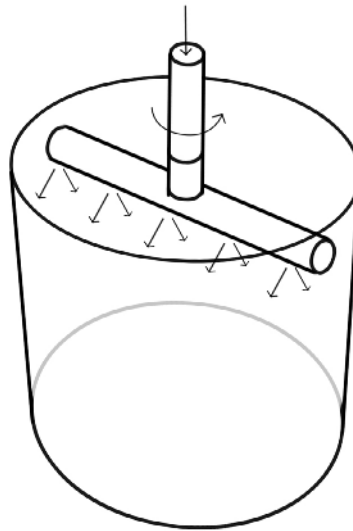
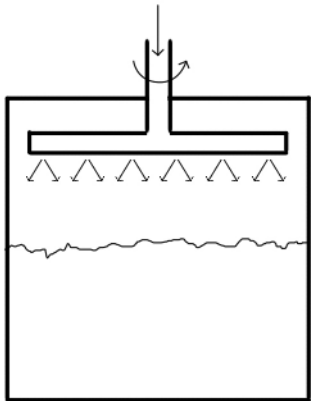

## 6.2 Indirect Heat Transfer

### 1. Coiled Copper tube at the bottom

Steam passing through coiled copper tube at the bottom of the vessel transfers heat to the rice. Copper is used as it has higher thermal conductivity.

In this, heat transfer takes place at the bottom, which may result in uncooked rice at the top.

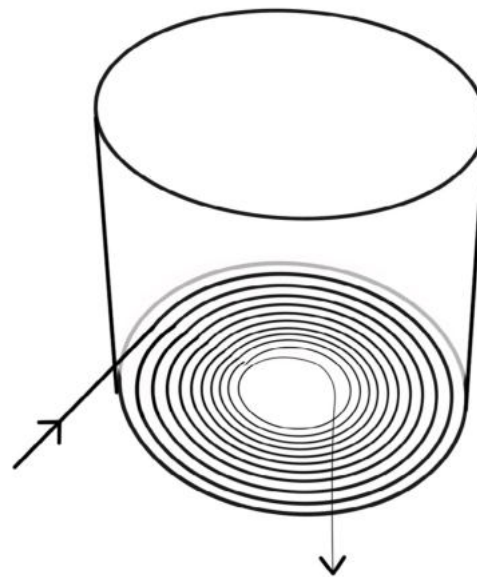
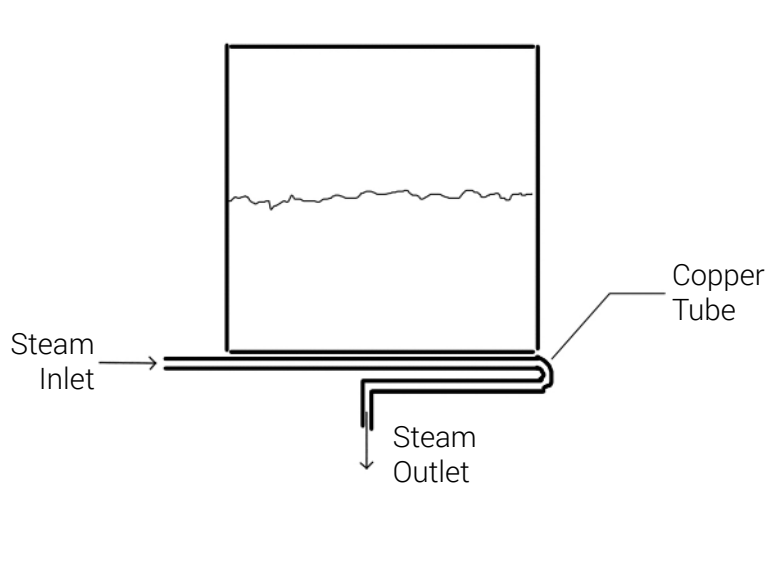

## Indirect Heat Transfer

### 2. Copper tube coil on whole vessel

To increase the duration for which steam transfers heat to the vessel, the copper tube is wound all around the vessel. Outlet of the copper tube is open to atmosphere.

As steam passes through the tubes at high flow rate, at the outlet we may get steam with slightly low temperature and heat is lost to the atmosphere without its full utilization.

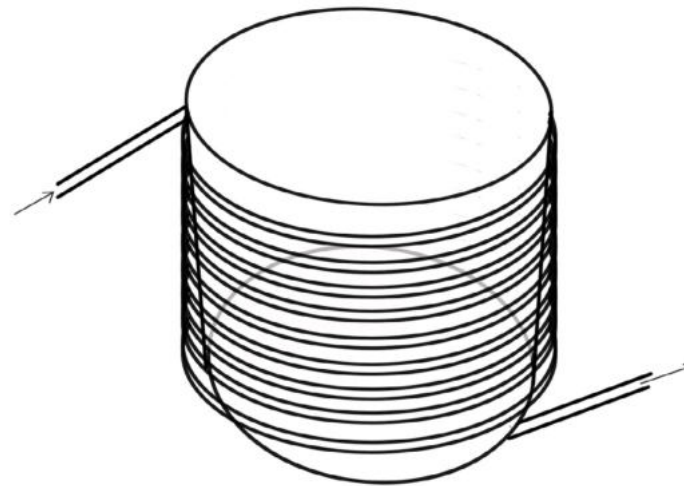
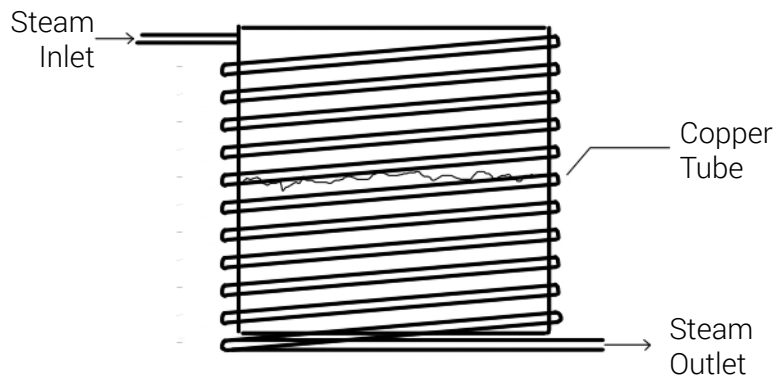

## Indirect Heat Transfer

### 3. Coiled Copper tube and steam recirculation

The steam coming out from the outlet is not released to atmosphere. Instead it is passed over the same tubes from outside. This arrangement helps in

better heat transfer than previous concept. But still we may get steam at outlet which is then released to atmosphere.

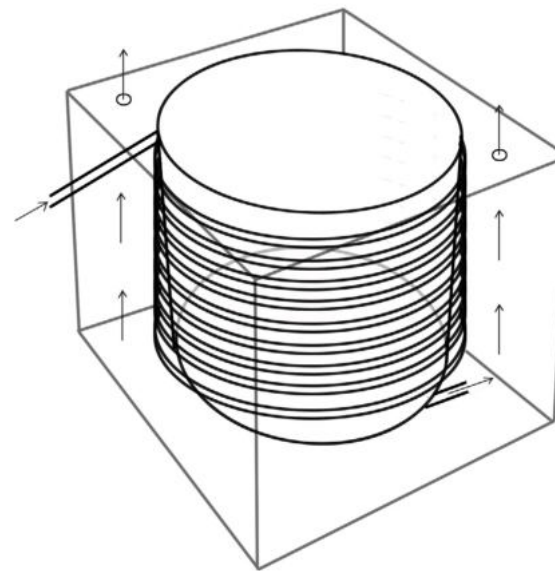
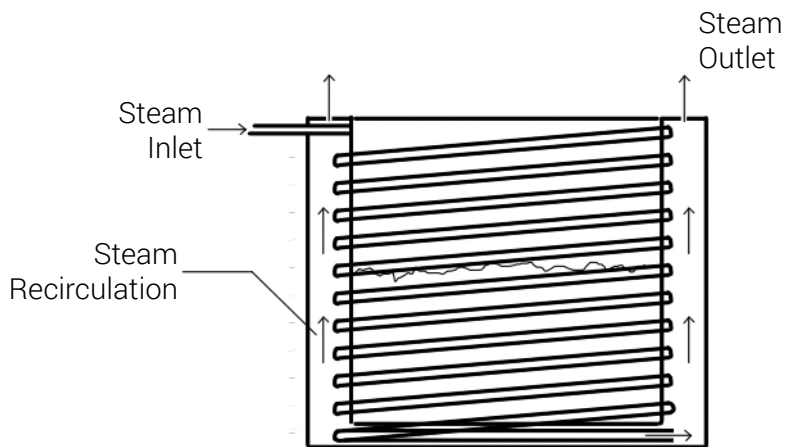

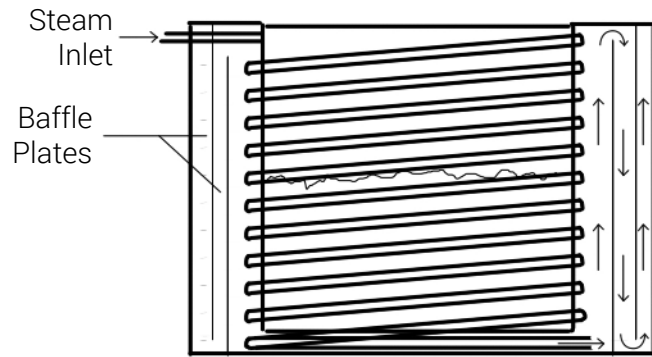

### Indirect Heat Transfer

#### 4. Coiled Copper tube & steam recirculation in multiple passes

In this, the steam coming out of copper tube is recirculated over the tubes from outside and again passed through a number of baffle plates so that during multiple passes,

steam transfers heat to the plates and overall temperature inside the system increases in short time. Also the steam loses heat and condenses to form water.

## Indirect Heat Transfer

### 5. Steam Passage through cylindrical pockets

In this, the cooking vessel is constructed in such a way that there are cylindrical pockets in vessel along the thickness. Modified shape will give extra strength to the vessel and it will also

help in better utilization of heat. However the steam pockets will be inaccessible for cleaning. Food stuck in crevices will be difficult to clean.

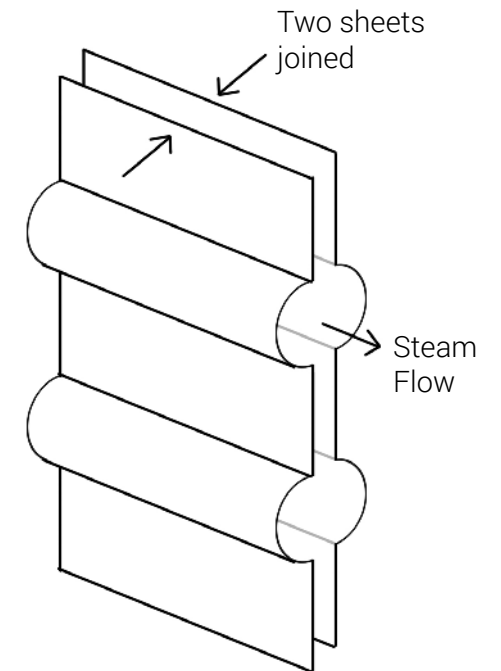
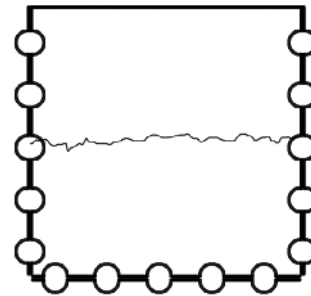
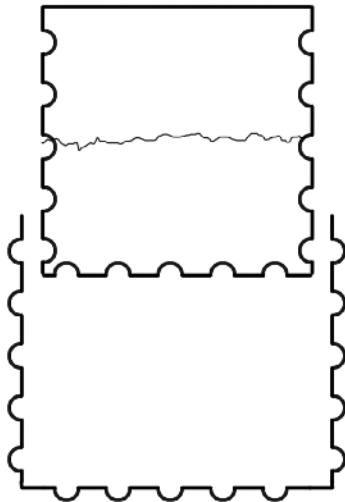

## Indirect Heat Transfer

### 6. Steam Circulation through square pockets

It is a bit modification in previous concept. Instead of cylindrical pockets, in this, the pocket cross section is square. It can be made from corrugated

metal sheets. But the same issues of cleaning will be present in this concept also.

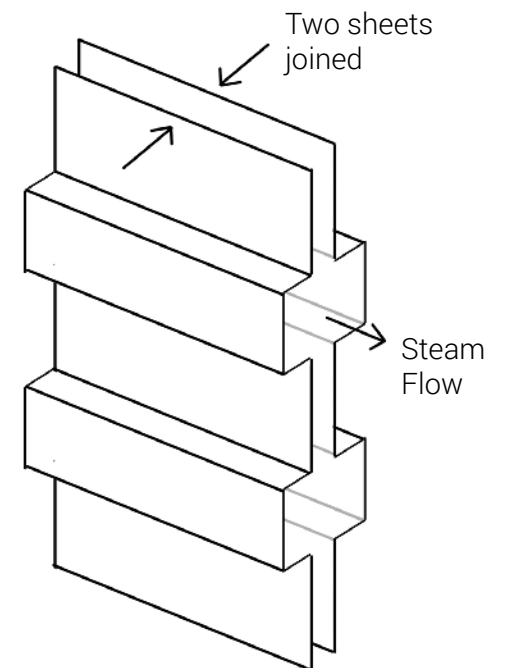
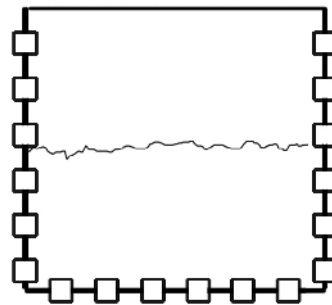
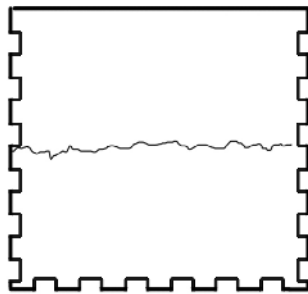

## Indirect Heat Transfer

### 7. Separate food container and steam jacket

In this, the cooking vessel is separate from the steam jacket and it can be removed for cleaning purpose. The steam is retained in the jacket as it transfers the heat to

the food container and condenses to form water.

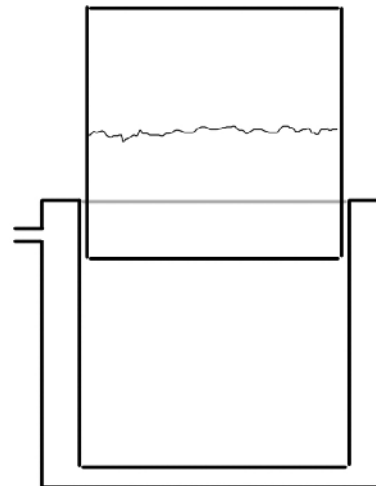
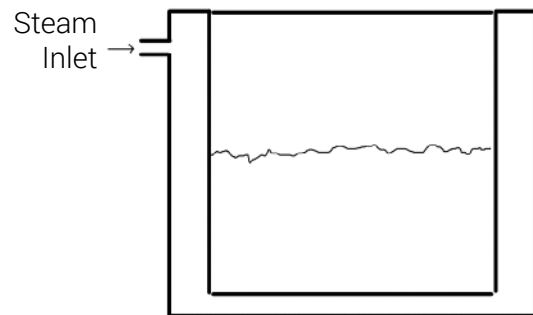

## Indirect Heat Transfer

### 8. Collapsible jacket using flexible bellow

It is a bit modification in previous concept. In this, the outer jacket is a collapsible bellow. The user will keep food container on the base of bellow and pull

its sides to attach it on the upper lip of food container. The bellow can expand to an extent when subjected to pressure due to steam.

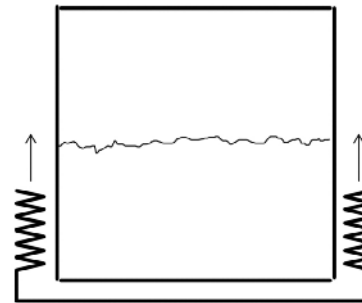
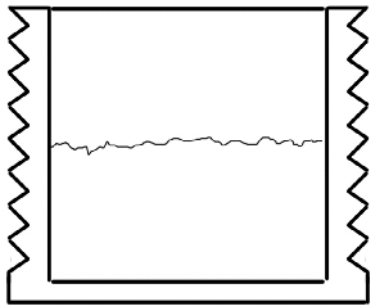

Based on parameters like effective utilization of steam, ease of cleaning and ease in manufacturing, following three ideas were chosen for further refinement.

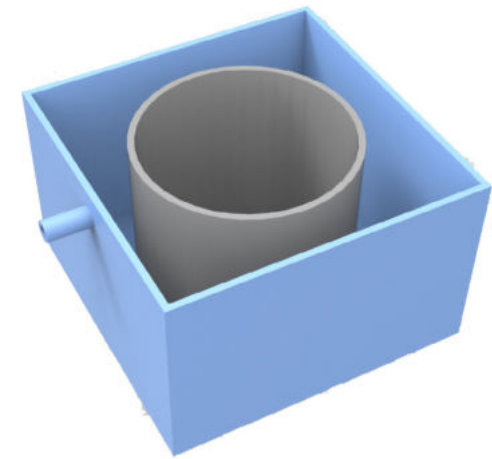
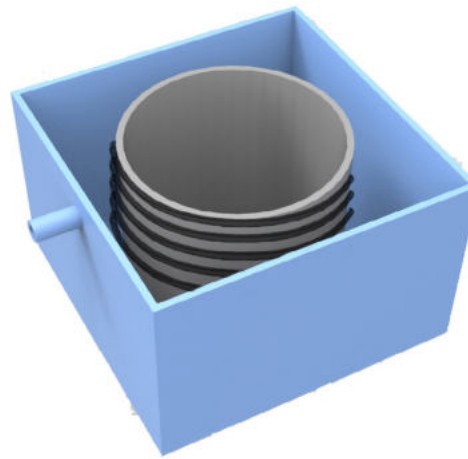
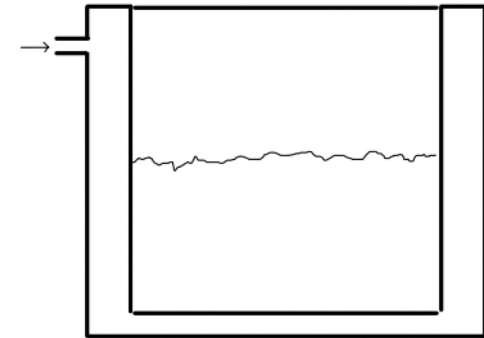
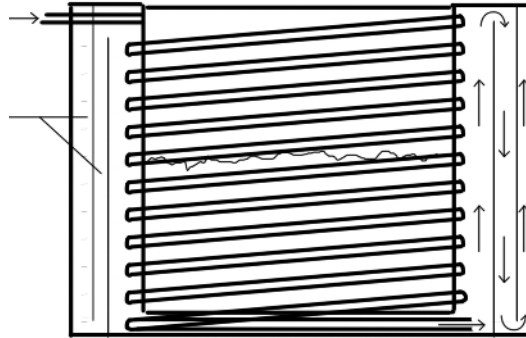
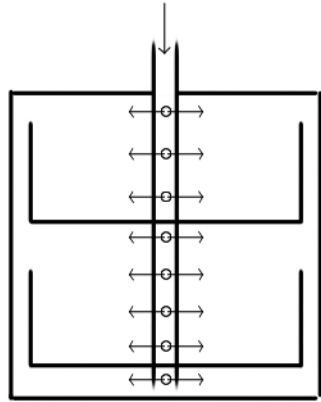



In this, the rice is heated with direct heating method. In direct heating, the steam is inside the food container. As steam cools down, it gets converted into water. This water will mix with rice and the water content of rice will become very high.

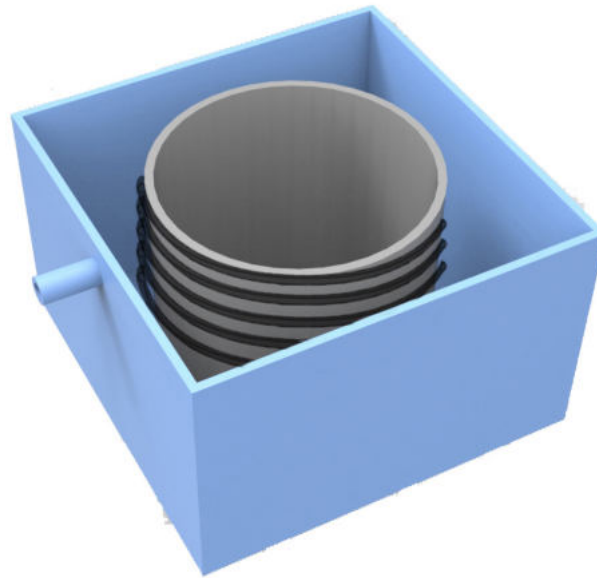

In this, the steam initially flows through copper tube. Scale formation may result in blockage of tube. Cleaning of tube is difficult.

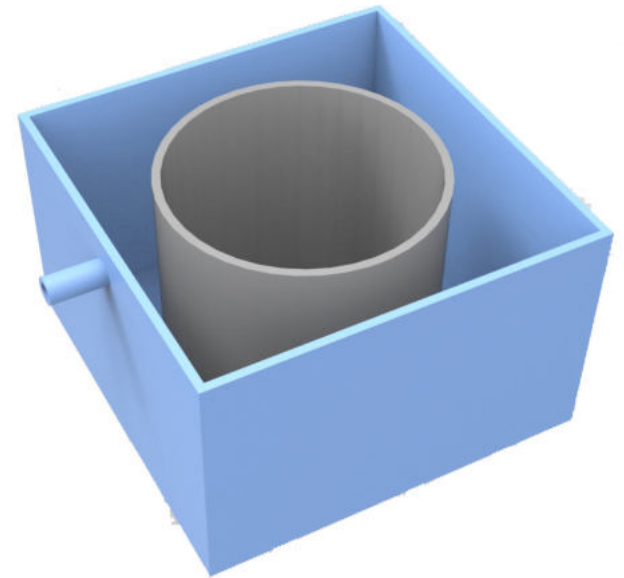

This ideas was taken for further development considering factors like ease in cleaning, simple and easy in manufacturing and number of components required.

The selected idea is further refined to details and various ways in which it can be used is also explored.

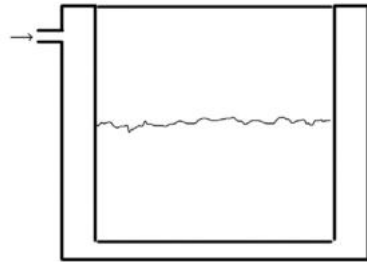

The food container is closed in a rectangular jacket which has opening at the top with a lid. The cylindrical container is kept on a wire mesh so that the steam condensate can

easily fall down and gets collected in the bottom of the jacket.

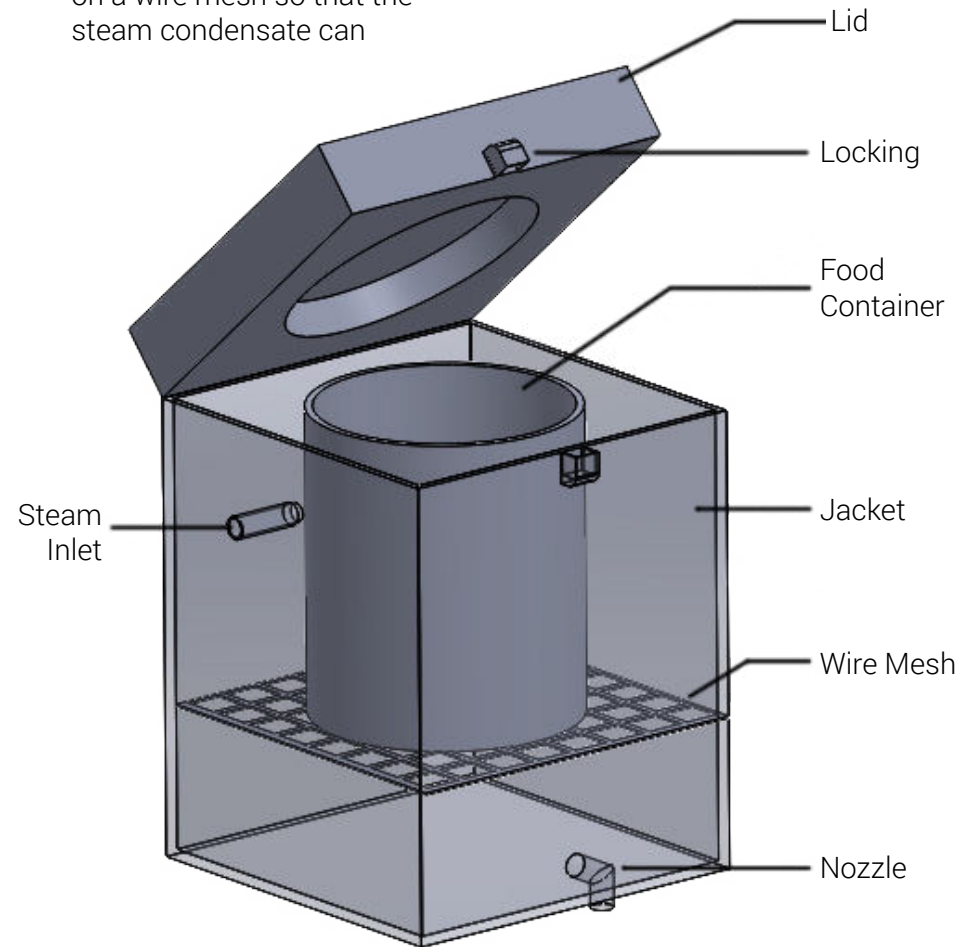
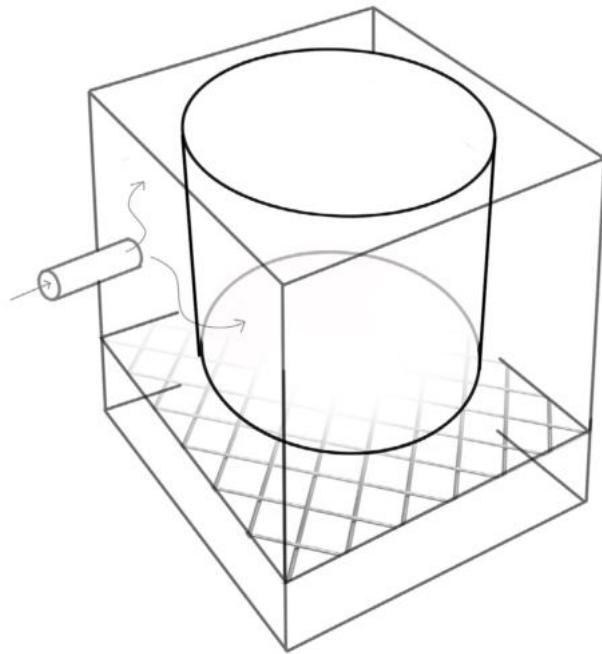

The opening of jacket is from side. It resembles with the microwave oven. The condensate gets collected in hot water tub at the bottom.

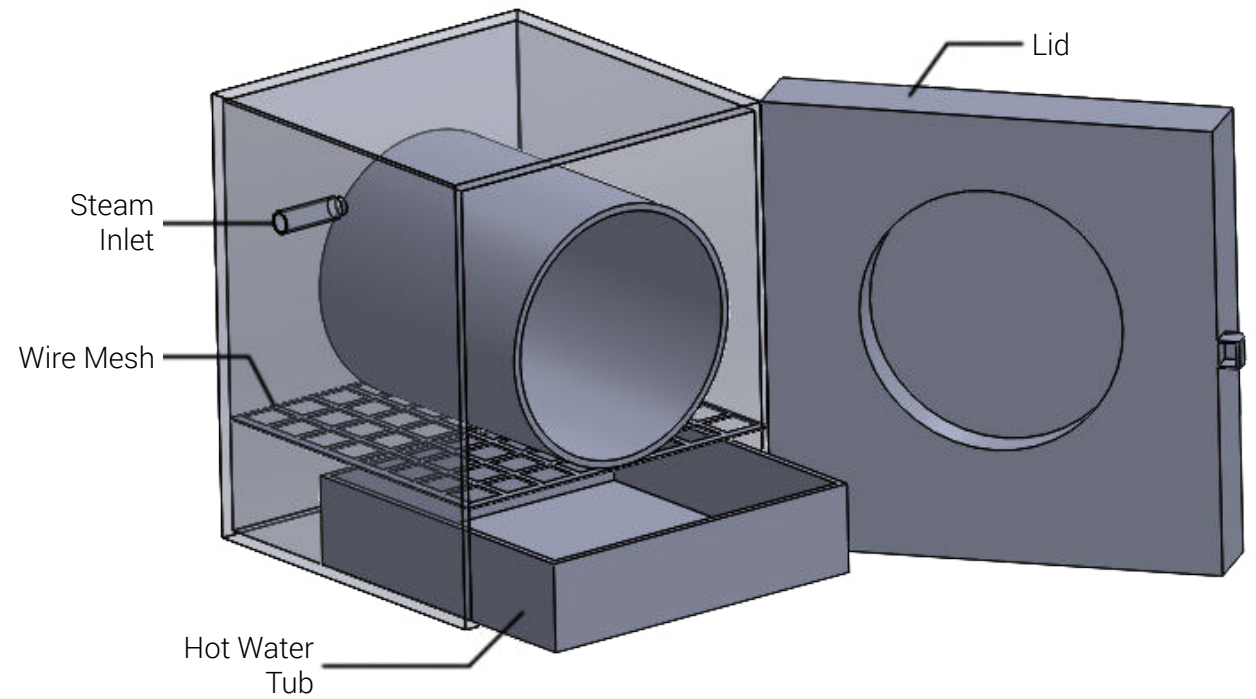
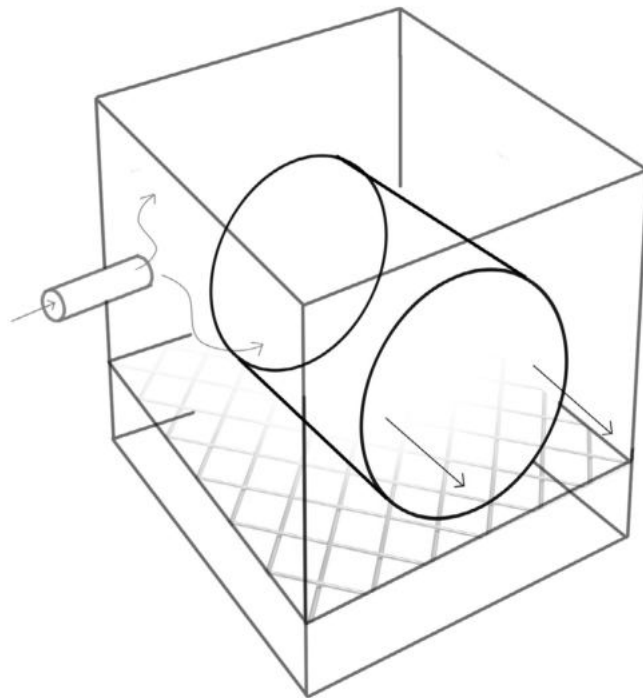

Two cylindrical vessels of different sizes are attached concentric to each other. Steam is introduced in the gap between two cylinders.

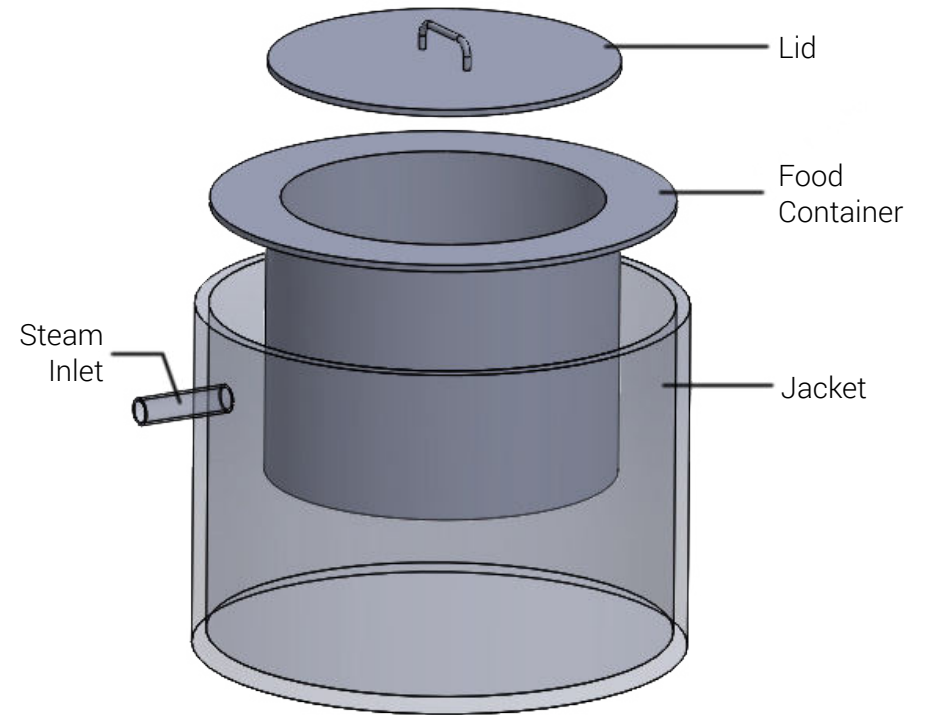
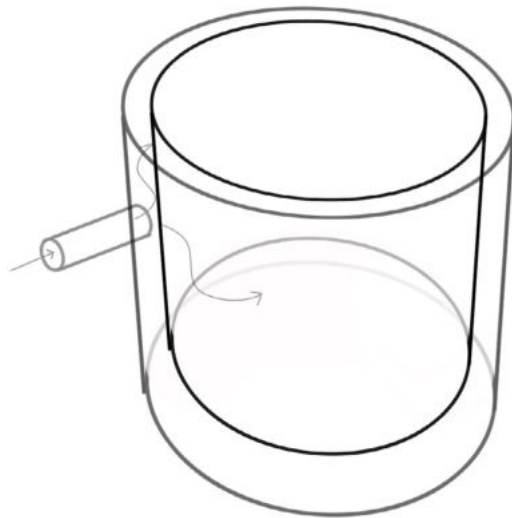
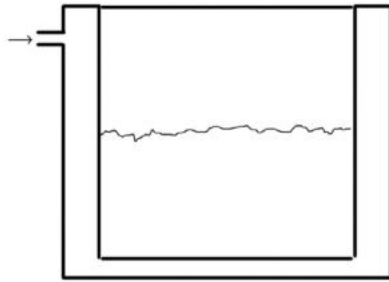

To decrease cooking time and effectively utilize the heat, size of food container is made small. Multiple food containers are placed inside the jacket.

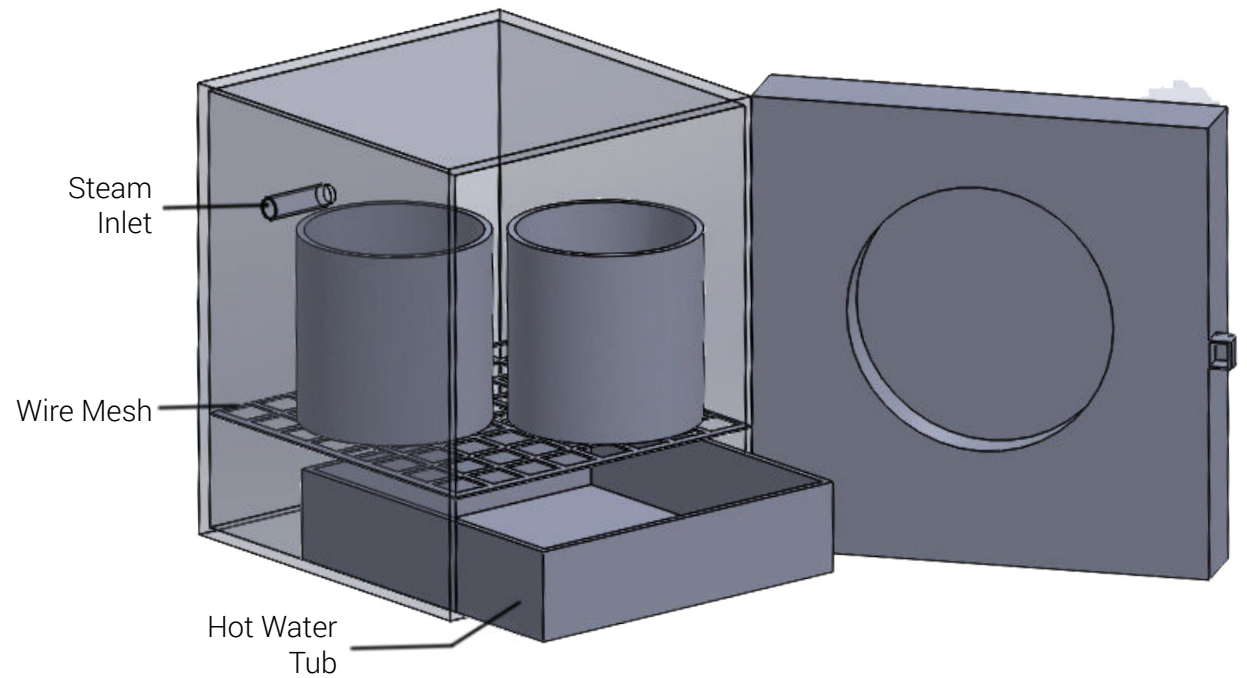
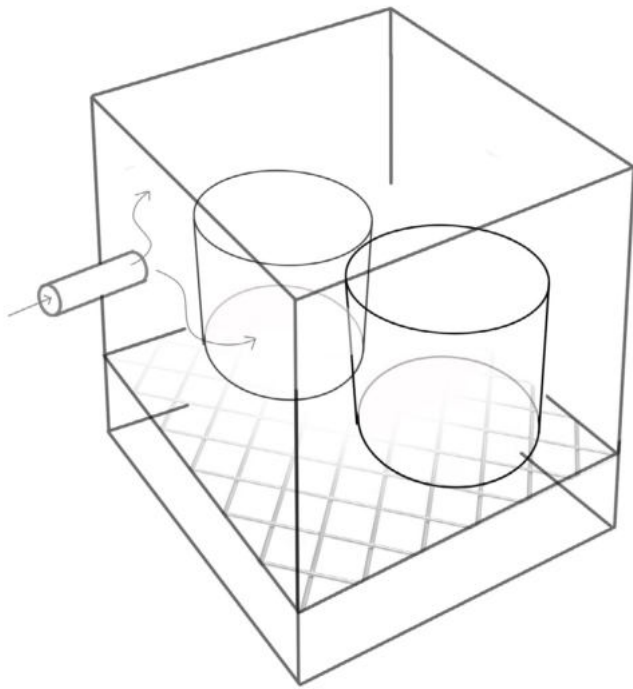
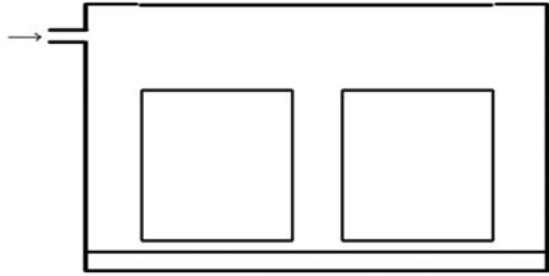

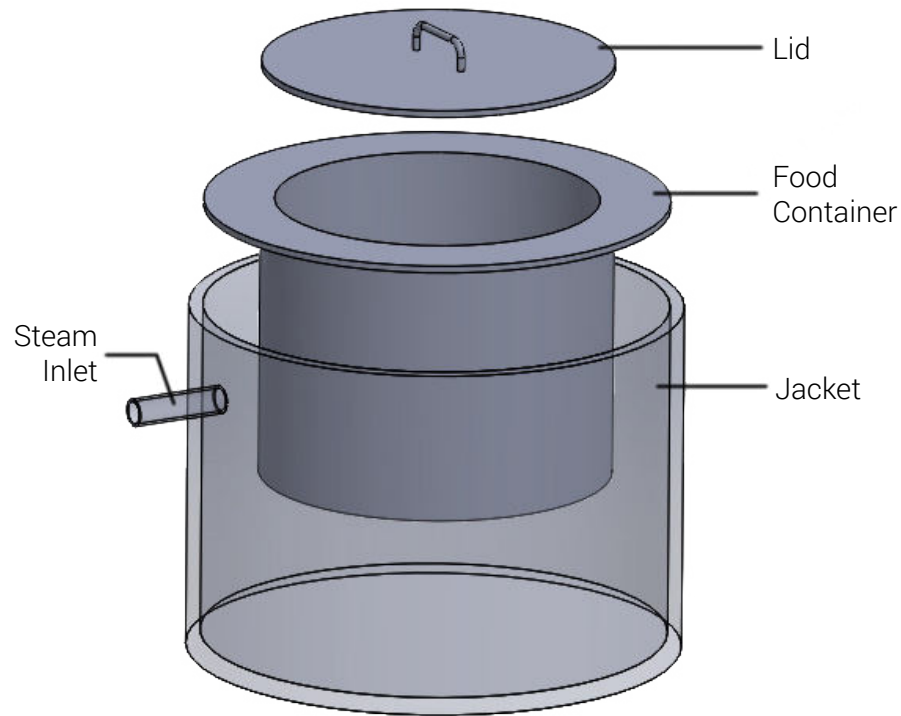

Out of the four different arrangements, the concept of cylinder inside a cylinder is taken ahead for further refinement.

The reason of selecting this arrangement of components is that it is easy to manufacture and simple to assemble.



Concept Evaluation

### 6.3 Concept Validation

Equipment - Cylindrical Jacketed Vessel (2.5 lit) without insulation and open from top

Experimental Conditions -

Time - 14:00 hr  
Month - February  
Place - Mumbai

Steam from 4 collector panels  
Steam Flow rate = 0.4 lpm  
At atmospheric pressure  
Single steam inlet and outlet  
Immediate steam exhaust  
Rice = 100 gm

Result -

Cooking time = 20 min

Conclusion -

Heat loss from wall of the vessel should be stopped  
Separate steam inlet and outlet needed  
Steam pipe connector required

During concept validation, the vessel used is not designed for higher pressure. Hence the steam is immediately released to the atmosphere without fully utilizing the heat of the steam.

hemispherical and calculations are done to find out overall dimensions of food container, jacket and wall thickness as well as the insulation thickness.

Ideally, the steam should get condensed inside the jacket for complete utilization of the heat. For this to happen, steam must remain inside the jacket for a longer duration of time.

If steam is allowed to remain in the jacket for a longer duration, it increases the inside pressure above atmospheric pressure. Therefore the cooking vessel should be designed to sustain the pressure above atmospheric pressure.

Generally, a cylindrical pressure vessel has hemispherical ends. Hence while designing, the bottom end of the cylindrical vessel is considered as

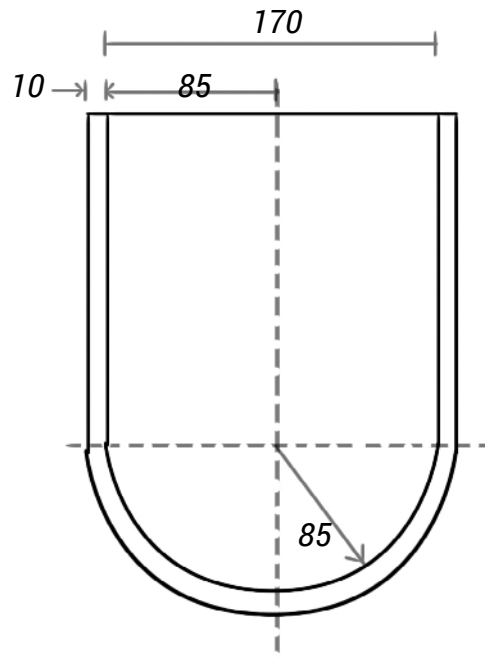
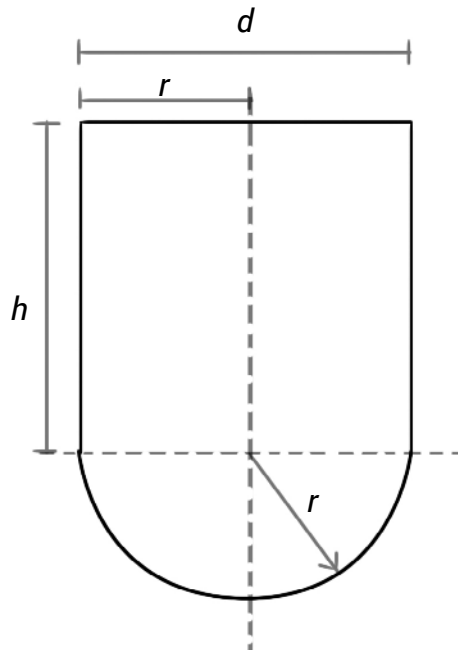

## 6.4 Calculation

Calculation for Overall Dimensions

Inside Volume = 5 L = 0.005 m<sup>3</sup> = 5 × 10<sup>6</sup> mm<sup>3</sup>

$$\begin{aligned}
 V_{\text{Total}} &= V_{\text{cylinder}} + V_{\text{hemisphere}} \\
 &= \pi r^2 h + \frac{2}{3} \pi r^3 \\
 &= \pi r^2 (2r) + \frac{2}{3} \pi r^3 \quad \dots \text{(assuming } h_{\text{cylinder}} = d = 2r) \\
 &= 2\pi r^3 + \frac{2}{3} \pi r^3 \\
 &= 2\pi r^3 \left(1 + \frac{1}{3}\right) \\
 &= 2\pi r^3 \times \frac{4}{3} \\
 &= \frac{8}{3} \pi r^3
 \end{aligned}$$

$$\therefore 5 \times 10^6 = \frac{8}{3} \pi r^3$$

$$r^3 = 5 \times 10^6 \times \frac{3}{8\pi} = 596831.03$$

$$r = \sqrt[3]{596831.03} = 84.19$$

$$r = 85 \text{ mm} \quad \& \quad d = 170 \text{ mm}$$

Jacket gap is assumed 10 mm so that condensate Easily flows downwards.

$$\therefore \text{Jacket diameter} = 170 + 10 + 10 = 190 \text{ mm}$$

## Designing for Circumferential Stress / Hoop Stress

For thickness of cylinder

$$\sigma_h = \frac{pd}{2t}$$

$\sigma_h$  = Hoop stress

$p$  = intensity of internal pressure

$d$  = internal diameter of cylinder

$t$  = thickness of shell

$$\sigma_h = 0.8 \sigma_y = 0.8 \times 215 \quad \dots (\sigma_y \text{ of SS 304 is } 215 \text{ MPa})$$

$$p = 0.7 \text{ N/mm}^2$$

$$d = 180 \text{ mm}$$

$$t = \frac{0.7 \times 180}{2 \times 0.8 \times 215} = 0.38 \approx 0.4$$

$$\therefore \text{Thickness of cylinder} = 0.4 \text{ mm}$$

For thickness of hemispherical bottom (welded)

$$\sigma_h = \frac{pd}{4t}$$

$$t = \frac{0.7 \times 180}{4 \times 215} = 0.15$$

$$\therefore \text{Thickness of hemisphere} = 0.15 \text{ mm}$$

$$t_{\text{cylinder}} > t_{\text{hemisphere}}$$

$$\therefore \text{Overall Thickness} = 0.4 \text{ mm}$$

For pressure vessels Factor of Safety is taken as 3.5

$$\begin{aligned} \therefore \text{Thickness} &= 0.4 \times \text{FOS} = 0.4 \times 3.5 \\ &= 1.4 \text{ mm} \end{aligned}$$

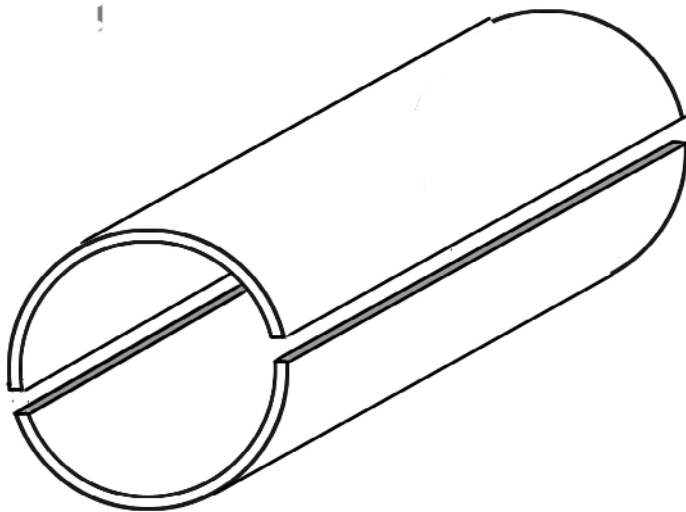

Failure of a cylindrical shell  
along the longitudinal section  
in Hoop stress

### Calculation Insulation Thickness

$$\text{Heat transfer, } Q = 2\pi kL \frac{(T_1 - T_2)}{\ln\left(\frac{r_2}{r_1}\right)}$$

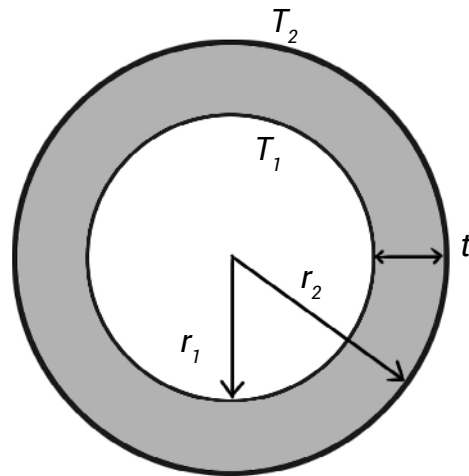

$k$  = thermal conductivity of insulating material in W/mK  
= 0.03 W/mK (for PU foam)

$L$  = length of cylinder in meter

$r_1$  = inner radius of insulation = 95 mm

$r_2$  = outer radius of insulation

$T_1$  = 100°C (temperature of steam)

$T_2$  = 40°C (assumed)

$$100 = 2\pi \times 0.03 \times \frac{(100 - 40)}{\ln\left(\frac{r_2}{r_1}\right)}$$

$$\ln\frac{r_2}{r_1} = \frac{2\pi \times 0.03 \times 60}{100} = 0.113$$

$$\frac{r_2}{r_1} = e^{0.113} = 1.119$$

$$r_2 = r_1 \times 1.119 = 95 \times 1.119 = 106.3$$

$$\text{Thickness of insulation} = r_2 - r_1 = 106.3 - 95 = 11.3$$

$$t = 11 \text{ mm}$$

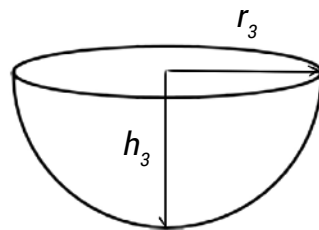
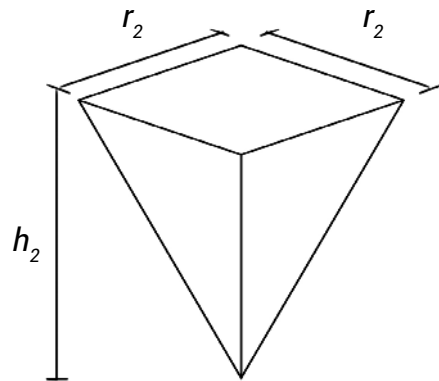
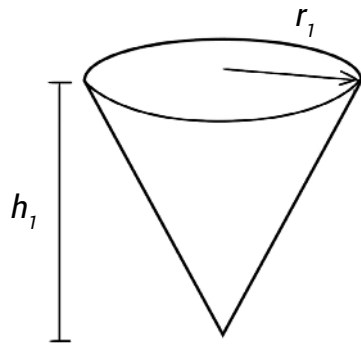

In cooking vessel, the steam enters from pipe near the opening of the vessel. The heat is transferred to rice through the surface of the inner cylinder. Also, as the steam continuously enters near the top area, the temperature in this region quickly rises. Ideally, the container shape should be such that surface area and volume is maximum at top and it decreases as we go down.

Tapering shapes can be cone, pyramid or hemisphere. To find out which of the three is best suited for the application, it is assumed that inside volume is constant and the top opening area is same in all the three.

$$V_{\text{cone}} = V_{\text{pyramid}} = V_{\text{hemisphere}}$$

$$\pi r_1^2 \frac{h_1}{3} = r_2 \times r_2 \times h_2 / 3 = \frac{2}{3} \pi r_3^3 \dots (1)$$

Equating opening area

$$A_{\text{cone}} = A_{\text{pyramid}} = A_{\text{hemisphere}}$$

$$\pi r_1^2 = r_2^2 = \pi r_3^2 \dots (2)$$

From equation (1) and (2)

$$h_1 = 2 r_3 = 2 h_3 \quad \& \quad h_1 = h_2$$

$$\therefore h_1 = h_2 > h_3$$

As height of hemisphere is smallest among the three shapes, it is the most convenient and appropriate shape for the vessel.

The vessel will be flat at the bottom for better stability when used for serving food.

Calculation for Overall Dimensions

Inside Volume = 5 L = 0.005 m<sup>3</sup> = 5 × 10<sup>6</sup> mm<sup>3</sup>

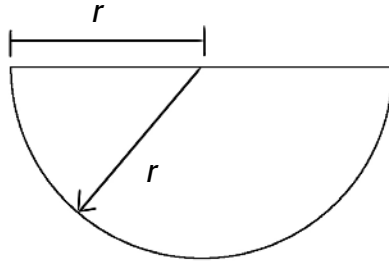

$$V_{\text{hemisphere}} = \frac{2}{3}\pi r^3$$

$$5 \times 10^6 = \frac{2}{3}\pi r^3$$

$$r^3 = \frac{5 \times 10^6 \times 3}{2\pi}$$

$$r = 133.65$$

$$d = 2r = 2 \times 133.65 = 267.3$$

$$d = 270 \text{ mm}$$

Jacket gap is assumed 5mm so that condensate Easily flows downwards.

$$\therefore \text{Jacket diameter} = 270 + 10 + 10 = 290\text{mm}$$

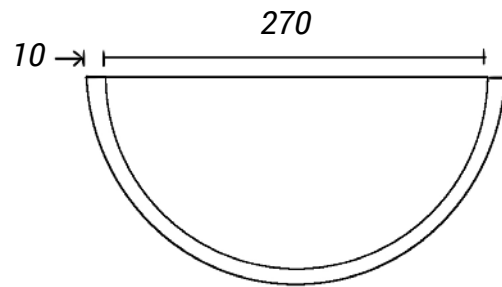

## Designing for Circumferential Stress / Hoop Stress

For thickness of hemisphere

$$\sigma_h = \frac{pd}{4t}$$

$\sigma_h$  = Hoop stress

$p$  = intensity of internal pressure

$d$  = internal diameter of cylinder

$t$  = thickness of shell

$$\sigma_h = \sigma_y = 215 \quad \dots (\sigma_y \text{ of SS 304 is 215 MPa})$$

$$p = 0.7 \text{ N/mm}^2$$

$$d = 290 \text{ mm}$$

$$t = \frac{0.7 \times 290}{2 \times 215} = 0.47$$

$$\begin{aligned} \therefore \text{Thickness of hemisphere} &= 0.47 \times \text{FOS} = 0.47 \times 3.5 \\ &= 1.65 \text{ mm} \end{aligned}$$

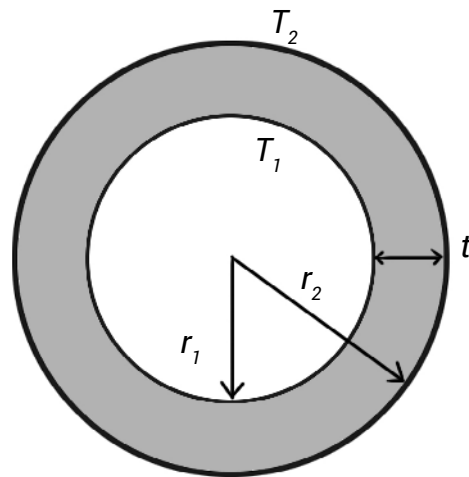

### Insulation Thickness Calculations

$$\text{Heat transfer, } Q = 4\pi k r_1 r_2 \frac{(T_1 - T_2)}{r_2 - r_1}$$

$k$  = thermal conductivity of insulating material in W/mK  
 = 0.03 W/mK (for PU foam)

$r_1$  = inner radius of insulation = 145 mm

$r_2$  = outer radius of insulation

$T_1$  = 100°C (temperature of steam)

$T_2$  = 40°C (assumed)

$$100 = 4\pi \times 0.03 \times 145 \times 10^{-3} \times r_2 \times \frac{(100 - 40)}{r_2 - r_1}$$

$$\frac{r_2}{r_2 - r_1} = 30.48$$

$$\frac{r_2}{30.48} = r_2 - r_1$$

$$r_1 = 0.96r_2$$

$$r_2 = \frac{r_1}{0.96} = \frac{145}{0.96} = 151.04$$

$$r_2 = 151 \text{ mm}$$

$$\text{Thickness of insulation} = r_2 - r_1 = 151 - 145 = 6 \text{ mm}$$

As we have considered formula for sphere, for hemisphere, the insulation thickness may be doubled

$$t = 12 \text{ mm}$$

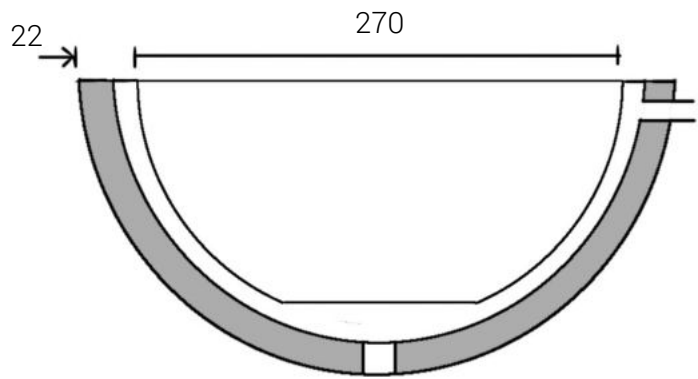

Dimensions

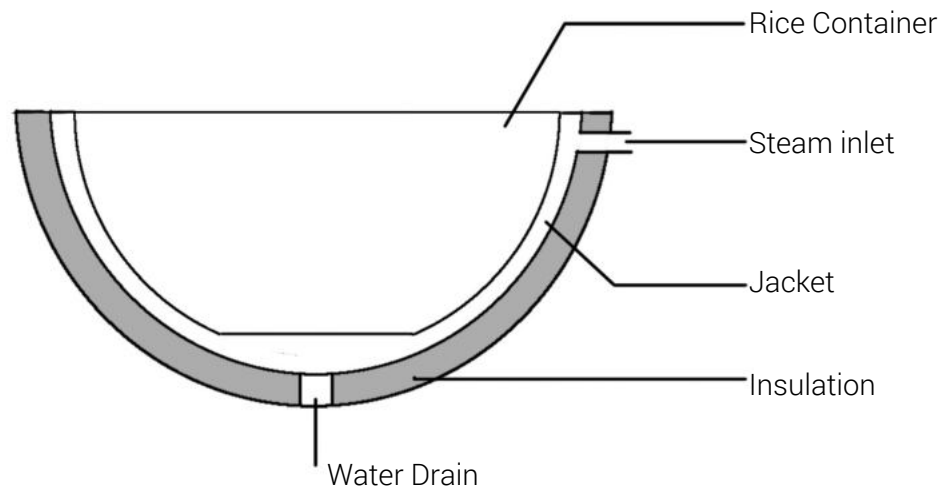

Components

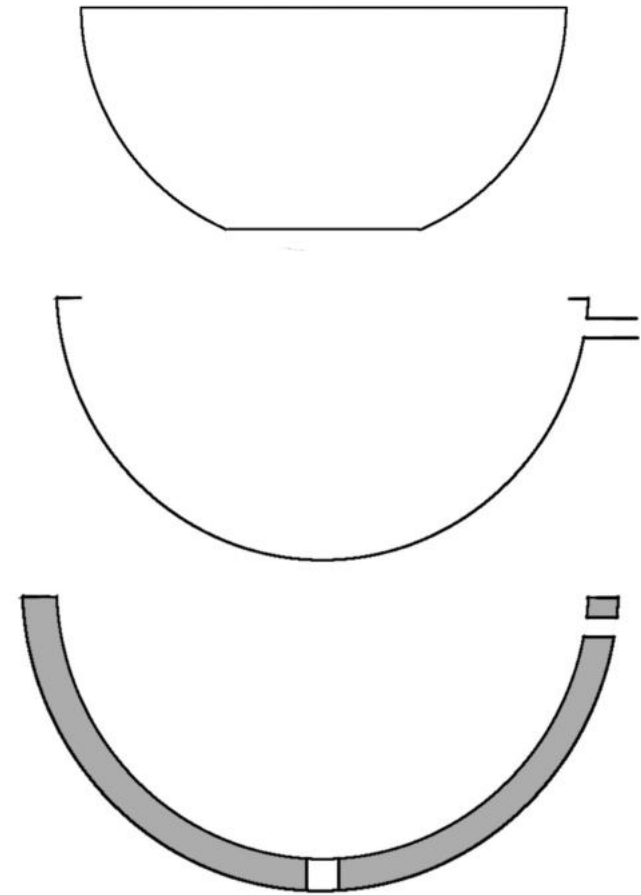

Exploded View

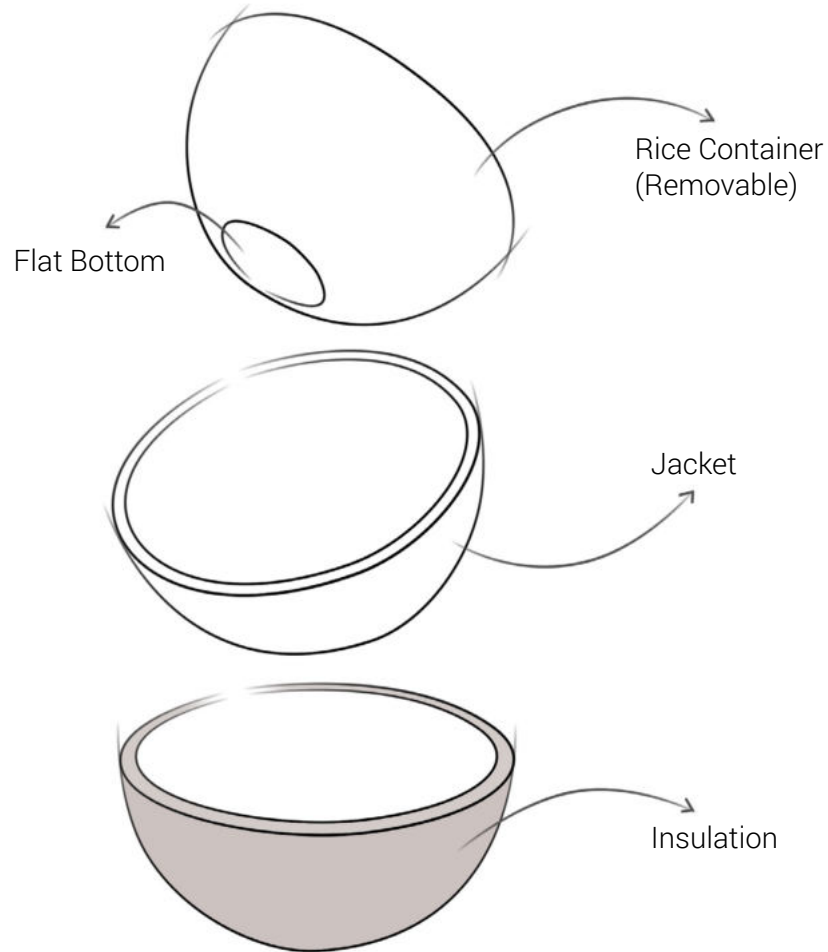

## 6.5 Final Concept

The final concept has a hemispherical rice container with flat bottom. The rice container is removable from the jacket and insulation so that it can be cleaned time to time. As the rice container is removable, jacket can also be accessed for cleaning. The rice container can also be used for serving the food. When steam generation is not sufficient, the rice container can be used to cook food by keeping it on gas burner. The material used for rice container is SS 304 because heat transfer through metal occurs at faster rate and it is food grade also.

The jacket is attached with permanent insulation from the outer surface. During design calculations, the material for jacket is considered as SS 304. As the food doesn't come in contact with the jacket, it is not necessary to have

food grade material for the jacket. Hence the jacket material considered is polycarbonate. Polycarbonate retains its mechanical properties at elevated temperature up to 140°C. It is light in weight, heat resistant and easy to manufacture. It is used in lenses, appliance covers, safety helmets, gears, hand tool castings and medical wares where boiling water sterilization is done.

Insulation helps to prevent heat loss. The material used for insulation is polyurethane foam. Due to insulation, the outer surface temperature of the cookware remains very low (close to 40°C).

The outer form of the cookware can be manipulated according to the usability, product expression requirements.

## 6.6 Product, User & Environment

Before venturing into the form explorations of the product, a comprehensive study was made on how user interacts with the device, in order to understand as to where and how the user wants the device to be kept in the kitchen, how does he perform different activities like closing and opening of steam valve, top lid etc.

The mock up had only four components outer casing, food container, lid and flexible hose pipe for steam.

Feedback was obtained from users by asking them questions in general discussion about the product.

A mock up was made and tested on different users, after explaining them about the product, its features and usage. Photo documentation was done along with the user feedback. These feedback were later on used to develop the form and refinement of the product.

Initial user testing was done in a kitchen like setup where counter height and width are considered according to standard dimensions.

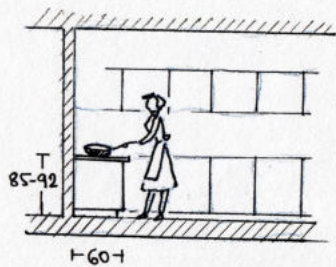
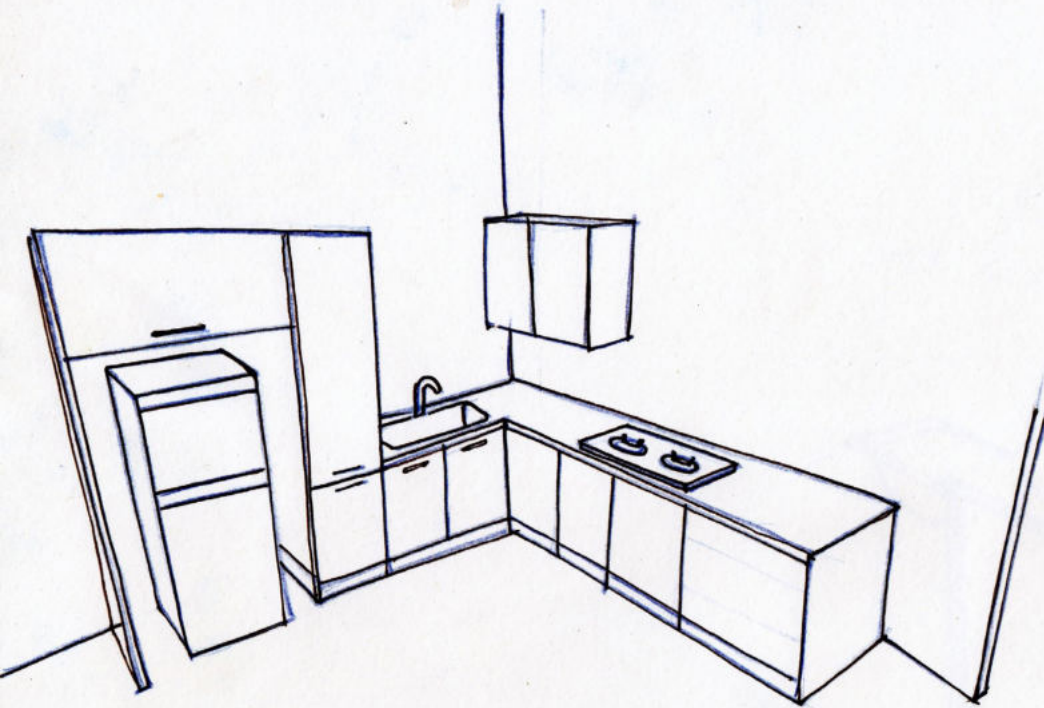

dimensions  
in cm.

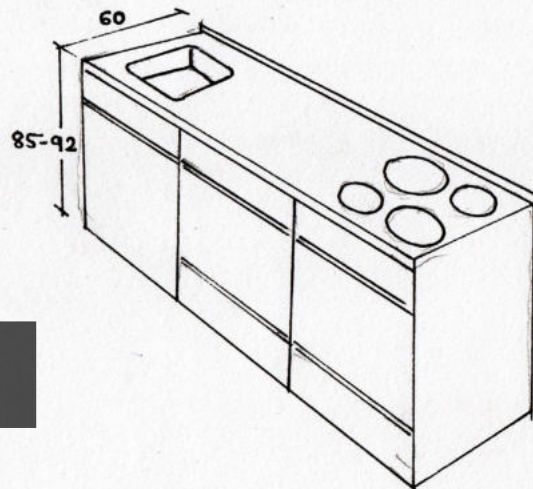

Kitchen Counter Standard  
Dimensions



Kitchen Setup



Initial Mock up

### Mock up 1

A block model of actual 1:1 scale is made using thermocol and styrene. Here importance was given more to the physical shape of the product and not the visual appeal.

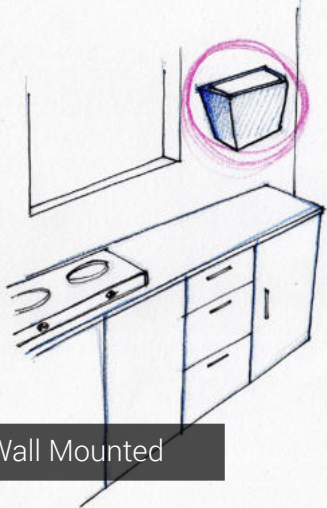

Wall Mounted



## 6.7 Position of Product Inside Kitchen

The discussion with the users took place in the form of informal questions as follows

Most of the users still preferred the product on the kitchen counter.

Q- Where would you like to keep this device in the kitchen?

Based on the user feedback the idea of keeping product on kitchen counter is taken forward and interaction of user with the product is studied through activity sequence analysis.

A- On the kitchen counter (100% user's answer)

Q- Where exactly on the counter?

A-

- Near the other equipments like mixer, microwave etc.
- Near the stove
- Near the window
- Near the sink

Q- If given other options for the location of this device in kitchen

- Wall Mounted,
- Below the counter, in a drawer

Would you change the preference of you location?

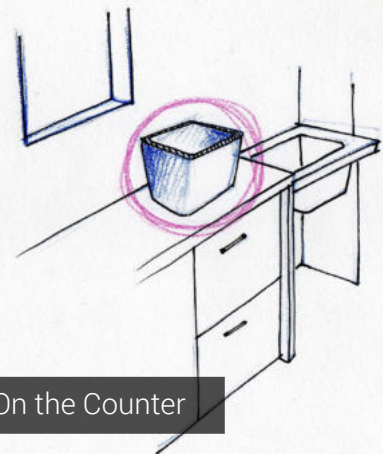

On the Counter

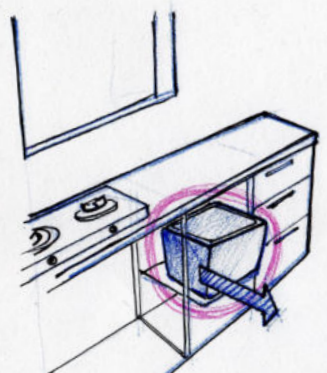

Below the Counter



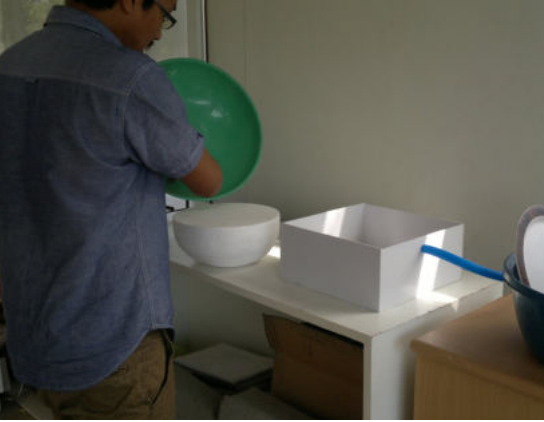

1. Pour raw rice in food container

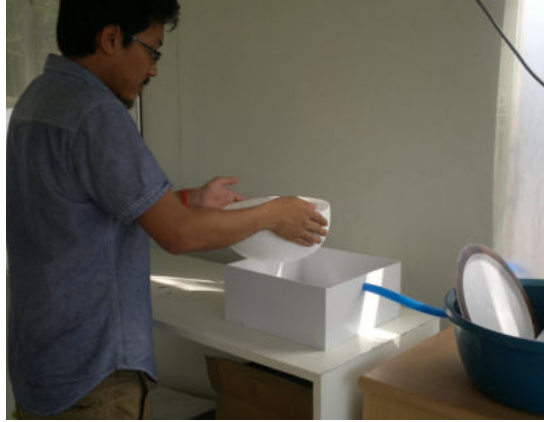

2. Lift the food container



3. Place it inside jacket



4. Close the lid



5. Start the steam valve



6. Take out the food container after switching off the valve and opening the lid

### Activity Sequence 1

User and product interaction is studied through recording each step of total activity of cooking rice. The entire process is repeated with multiple number of users so that different practices of handling of product by various users are taken into account with their feedback on the entire activity sequence.

With mock up 1, the activities recorded are

1. Pour raw rice in food container
2. Lift the food container
3. Place it inside jacket
4. Close the lid
5. Start the steam valve
6. Take out the food container after switching off the valve and opening the lid

During these steps, most number of users found difficulty in step no 3 which is placing the container in the jacket. This was due to the fact that the user had

to twist the wrists while placing the food container inside the jacket.

Another issue faced by the users was while taking out the cooked rice container from the jacket when cooking is complete. There is no provision to hold the hot vessel while taking it out. These issues are taken into consideration for making mock up 2.

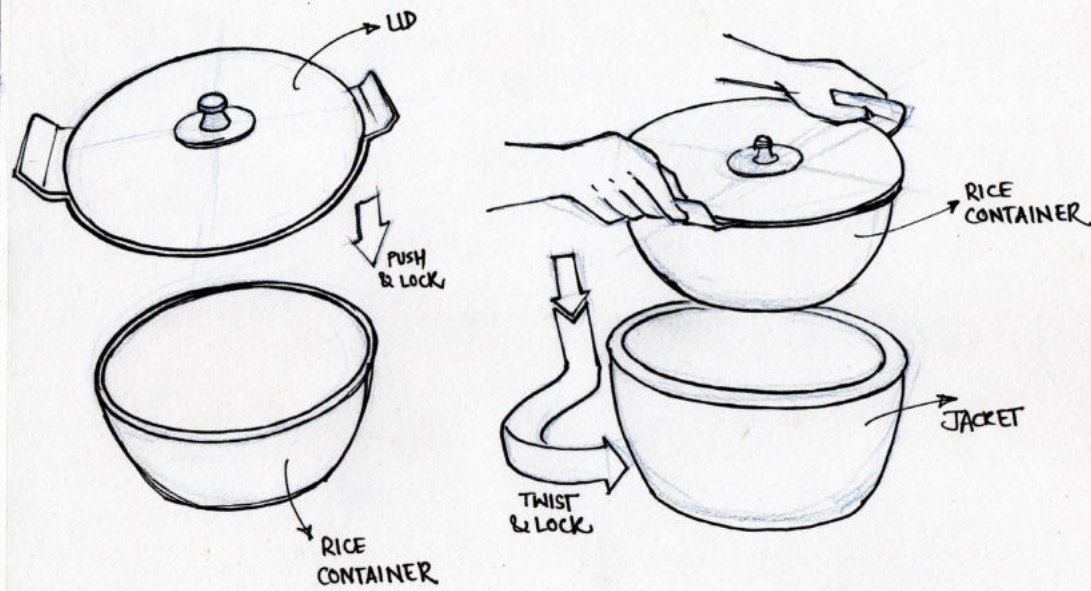

## Mock up 2

Modifications and refinements of ergonomics of the product are done in mock up 2 according to the user feedback obtained while testing mock up 1. In this, the lid is provided with the handle. The food container is first closed with the lid and then lifted with the handles on the lid.

sketch alongside. Again a quick mock up is made to test with users to find issues they face while handling the product.

It is then put into the jacket from the top and locked by twisting as shown in the





1. Pour raw rice in food container



2. Close the lid



3. Lift food container holding handle on lid



4. Twist & lock



5. Start the steam valve



6. Take out the food container after switching off the valve and opening the lid

## Activity Sequence 2

Problem faced by users during performing the task in found in activity no. 6 which is opening the lid once the food is cooked. To open the lid user has to hold the hot container. The provision is needed to open the lid without touching the hot container.

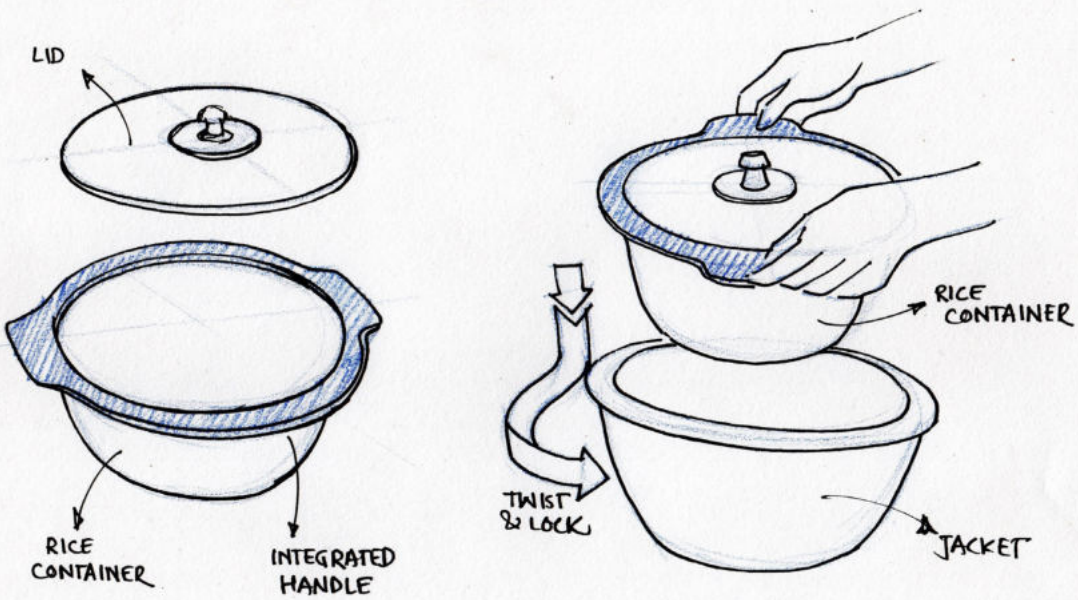

### Mock up 3

In this, the food container provided the handles and not the lid. The lid is just kept on the top of the container. The rice container is lifted by user with the help of handle grip provided.

It is then put into the jacket from the top and locked by twisting as shown in the sketch alongside.



Integrated Handle





1. Pour raw rice in food container



2. Close the lid



3. Place in it inside jacket



4. Start the valve



5. Switch off the valve  
Take out the food container



6. Opening the lid

### Activity Sequence 3

Mock up 3 is tested with actual users to get their feedback. Various feedback obtained is as follows

1. The place of every equipment in kitchen is fixed and they are not moved to other locations frequently by most of the users.

This led to the conclusion that the product should also have a fixed position and provision of flexible steam inlet and water drain is not necessary.

2. Users were concerned about the flexible pipe connection safety. The issue raised was, during vegetable chopping and other activities, the pipe may get cut. Also it will get tangled with other utensils kept on the counter.

Based on the user feedback, necessary modifications are done and different arrangements are explored.

1

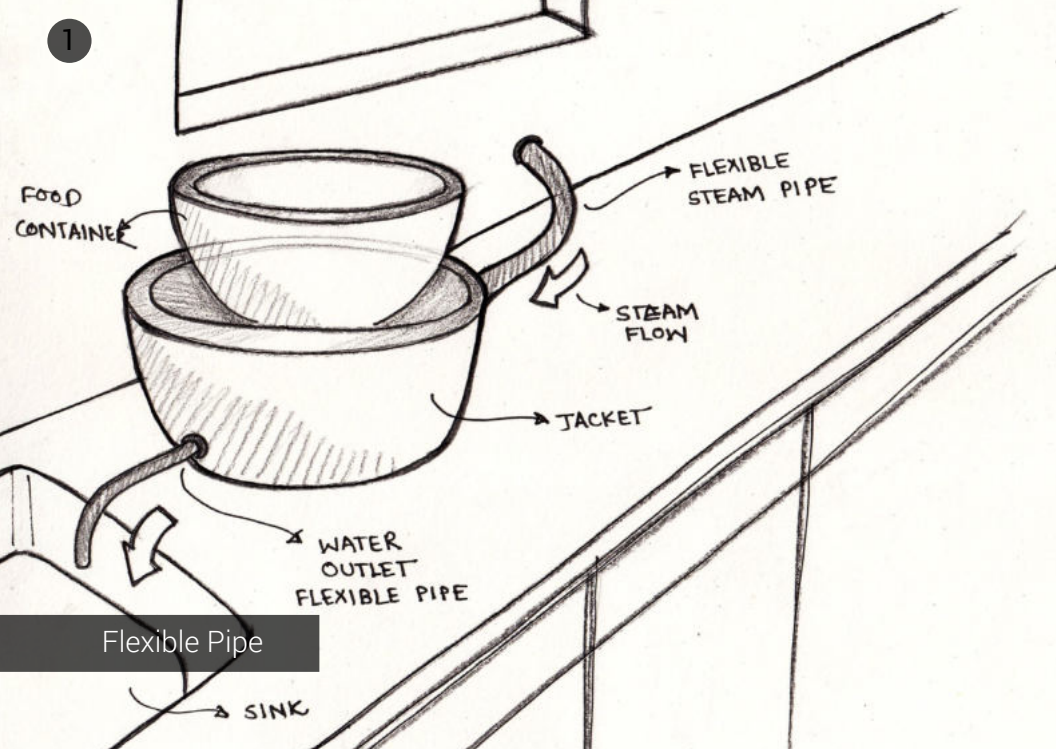

Flexible Pipe

3

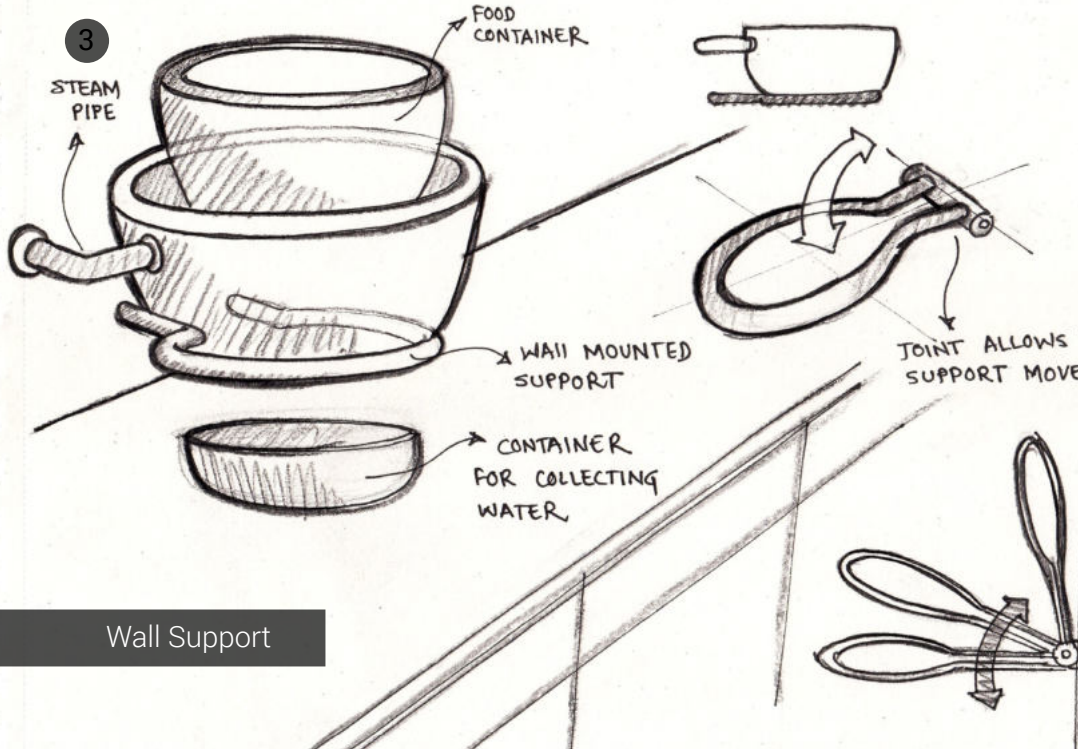

Wall Support

2

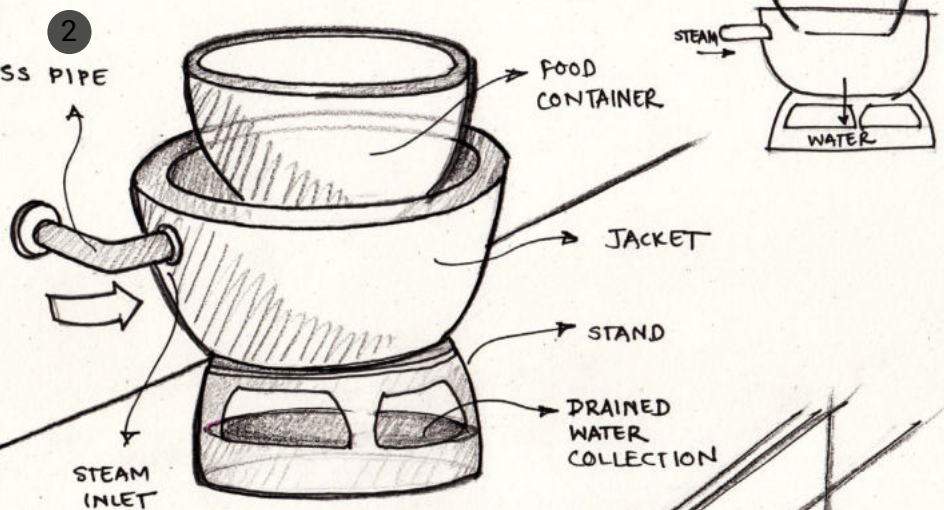

Stand cum Water Collector

4

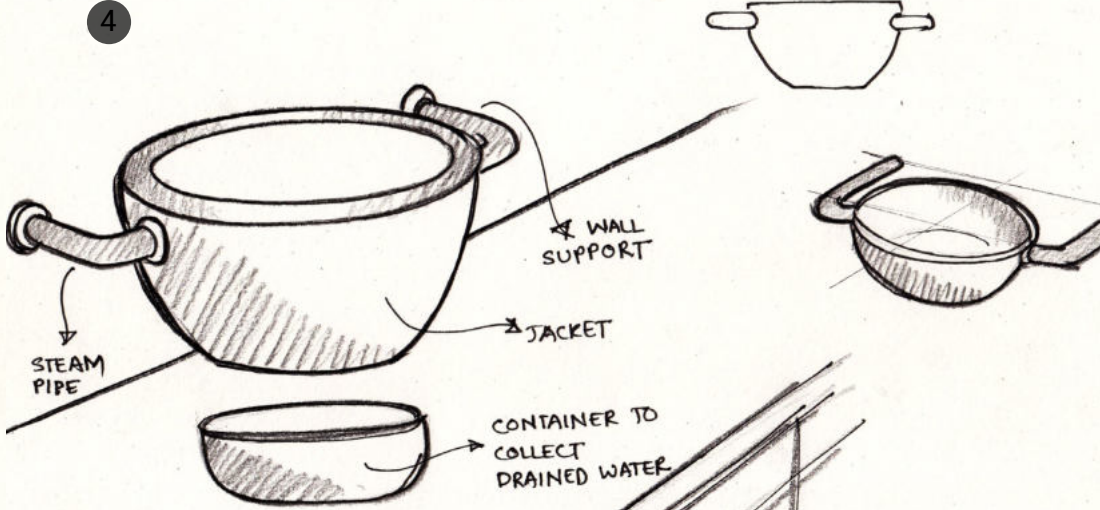

Steam Pipe as Wall Support

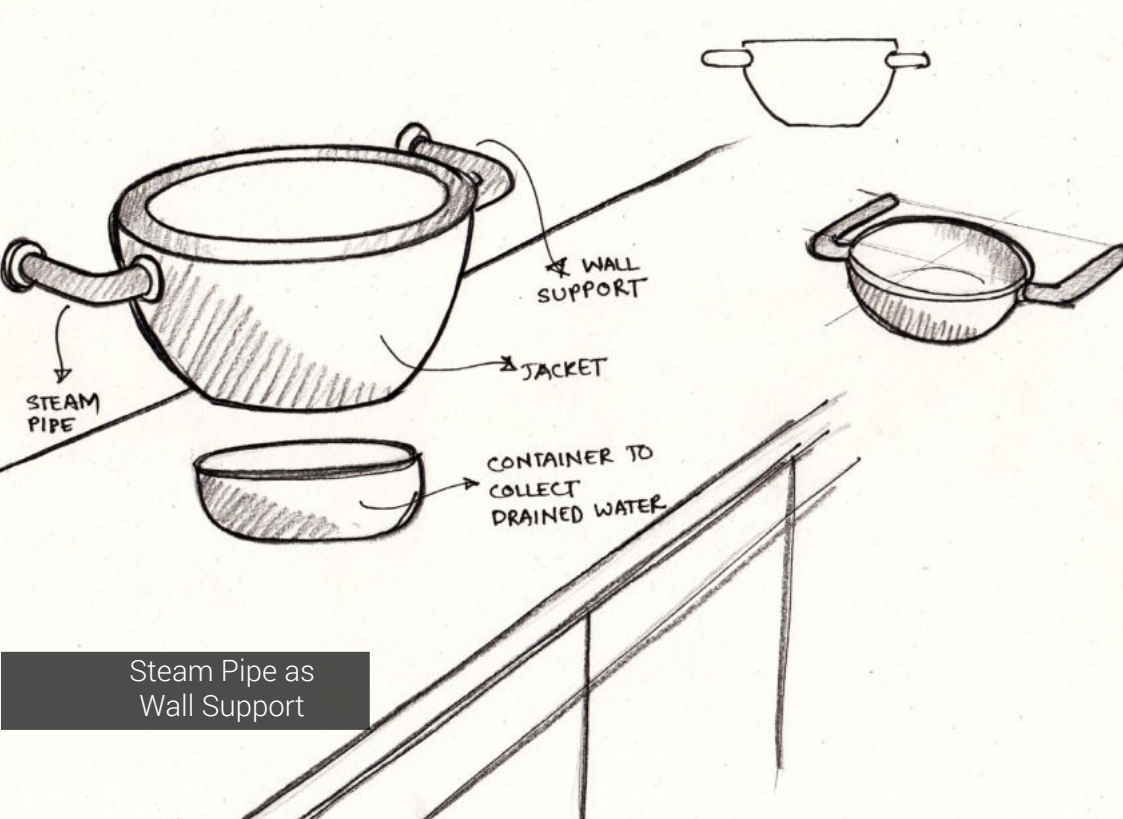

Steam Pipe as Wall Support

#### Mock up 4

The selected arrangement is steam pipe connection as wall support. Mock up is made for user testing. Steam pipe is attached with the wall at appropriate height above the kitchen counter.



Steam Pipe as Wall Support





1. Put Jacket in place



2. Pour Rice in Container



3. Close the lid



4. Put Rice Container inside jacket



5. Switch on the valve

#### Activity Sequence 4

User testing is done for the final arrangement to get necessary feedback on usability issues. Testing is done with multiple number of users.



1. Put Jacket in place



2. Pour Rice in Container



3. Close the lid



4. Put Rice Container inside jacket



Activity Sequence



5. Switch on the valve



6. Align pipe with the wall



### 6.8 Understanding Existing Kitchen Appliances

A number of kitchen appliances are studied to get a fair idea about the prominent features, shape, size, height, roundness, edge radius etc.

### Color Pallet

Kitchen Appliance color pallet mainly consists of white and shades of grey. Detailed color pallet is shown besides each image.



Kitchen Appliances



## 6.9 Keywords and Mood Board

Created to get inspiration for visual appeal in the form and detailing of the product.

### Keywords

Solar  
 Sustainable Home Appliance  
 Family Clean Fuel Cooking  
 Energy Saving Tasty Food Steam  
 Technology Quality  
 Rice Hygienic Fresh  
 Natural Ergonomic  
 Kitchen Safety easy-to-use  
 Soft Transition  
 Classic Feel Premium  
 Appealing Pure



### Mood Board

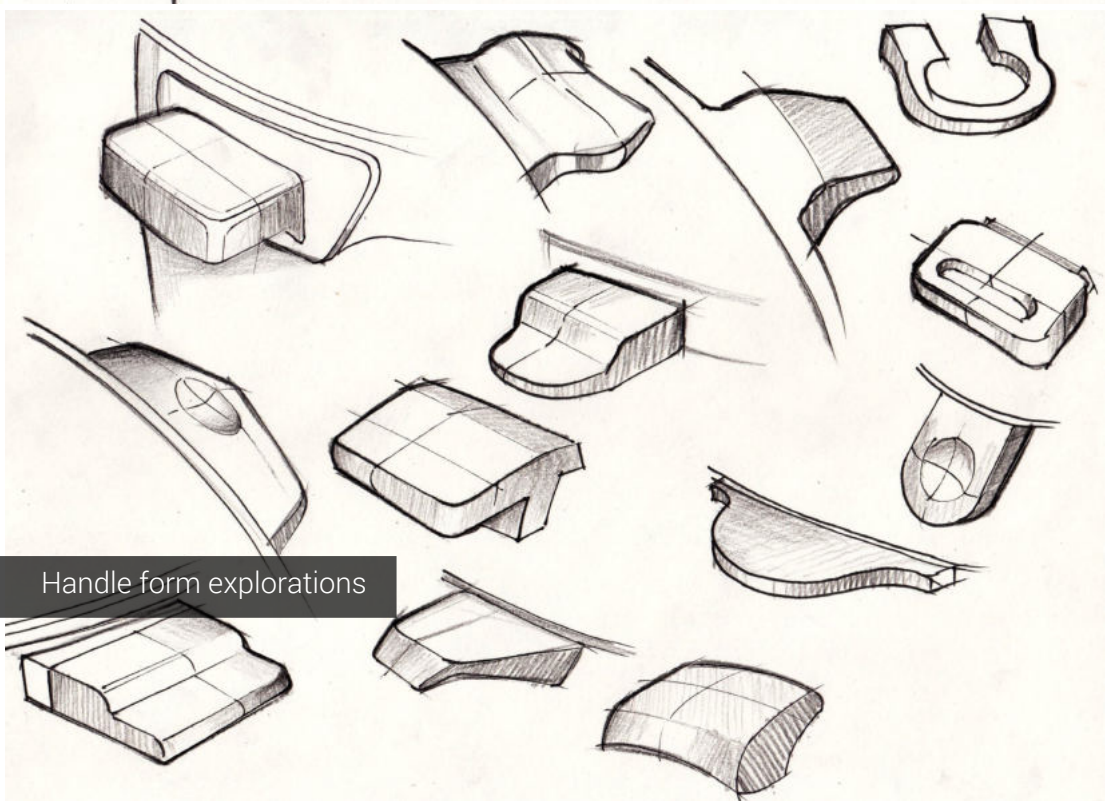
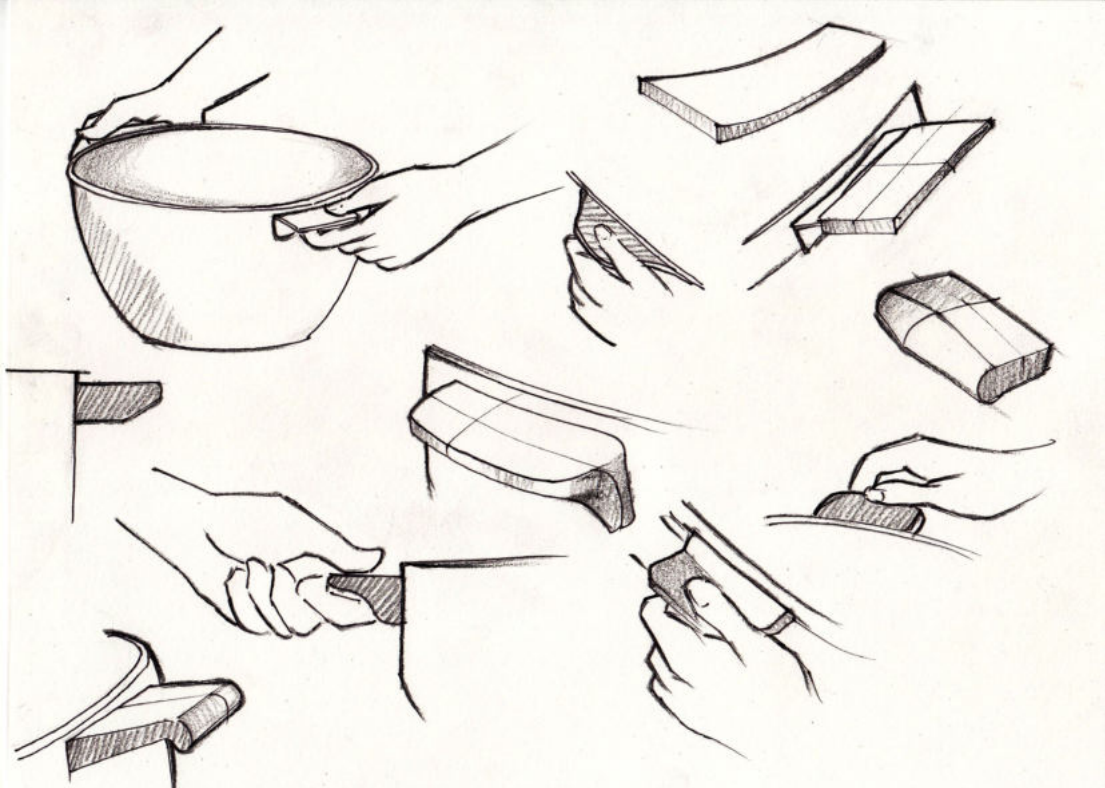

Handle form explorations

### 6.10 Handle on Food Container

Explorations were done to achieve desired form of the handle, used for lifting hot food container, keeping the mood board and keyword for form explorations in mind.

Aspects focused during explorations were ensuring ample space for fingers to grip the handle firmly and protection of fingers from hot container.

The ring serves the function of sealing the gap between jacket and the food container and it acts as an aesthetic element as well because of the smooth transition between ring and the handle.

The raised dimples on handle ensures good grip even when hands are wet. A small step on the handle provides a place for thumb rest. Extended part of the handle below the thumb

grip is provided to ensure that the index finger is also protected from touching the hot container.

Appropriate dimensions for the handle were decided after making a few mock ups and testing it with different hand sizes.

The material used for handle and the ring is heat resistant melamine. The function of handle is simple and easy to understand.

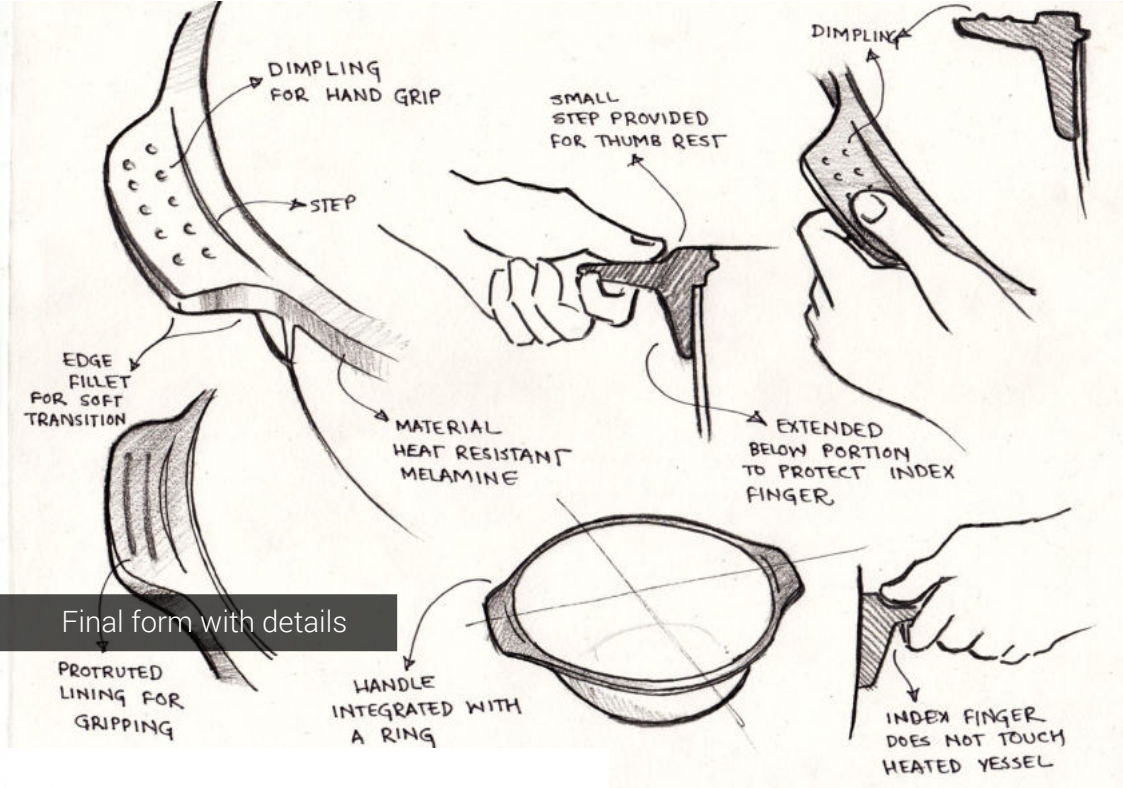

Final form with details

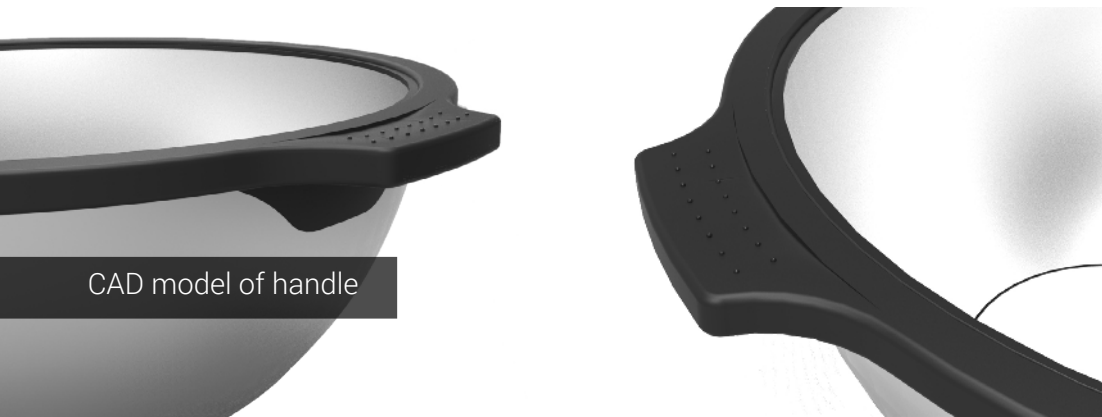

CAD model of handle

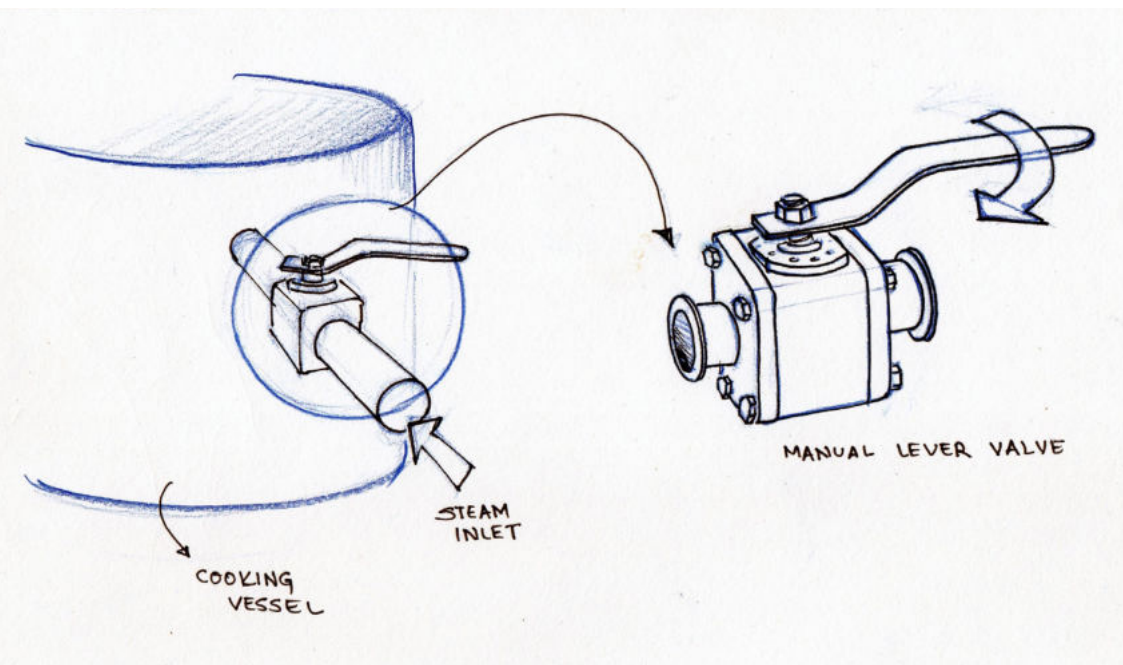

### 6.11 Steam Inlet Valve

In order to control the steam flow, the steam inlet pipe should have a flow control valve. The valve has to be either manual or battery operated. The manual valves available have hand operated lever or wheel to control the steam flow rate.

These valves are generally used in industries for flow control and when used for a cookware, it gives a feel of industrial equipment rather than a kitchen gadget.

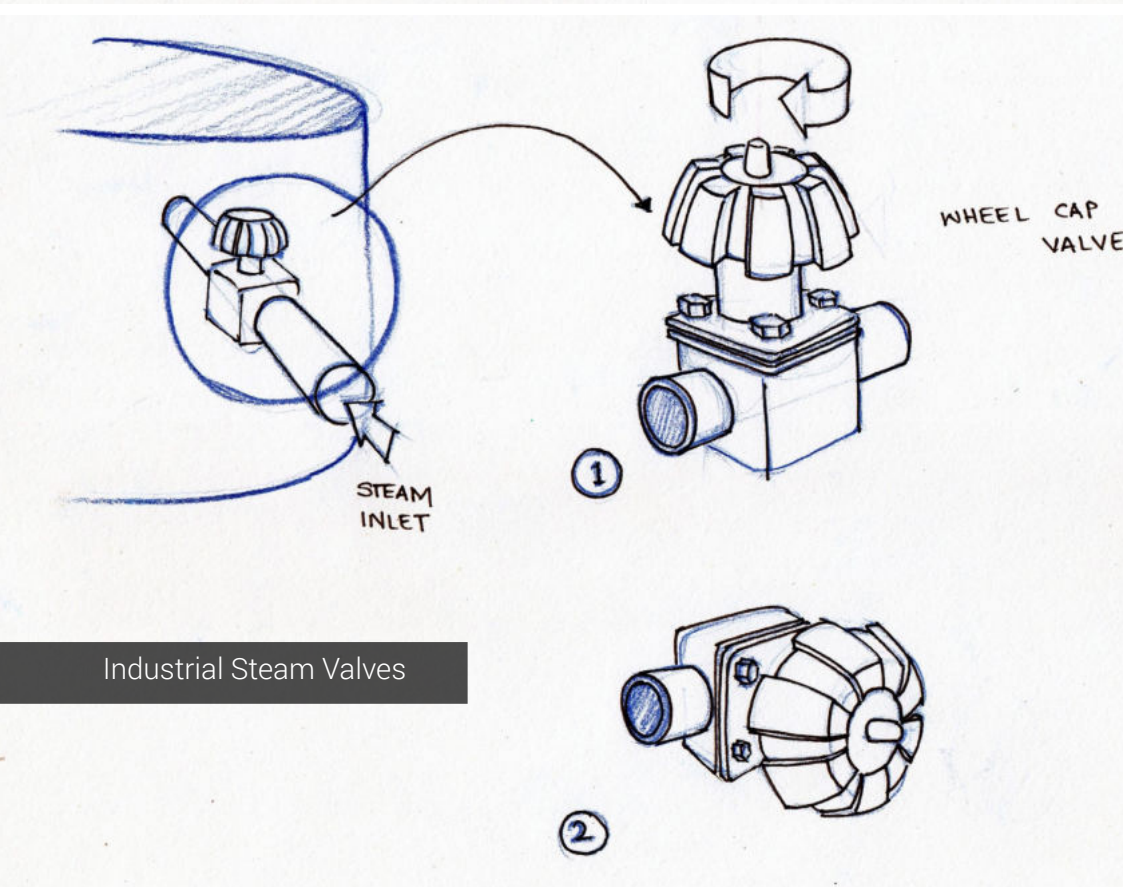

Industrial Steam Valves

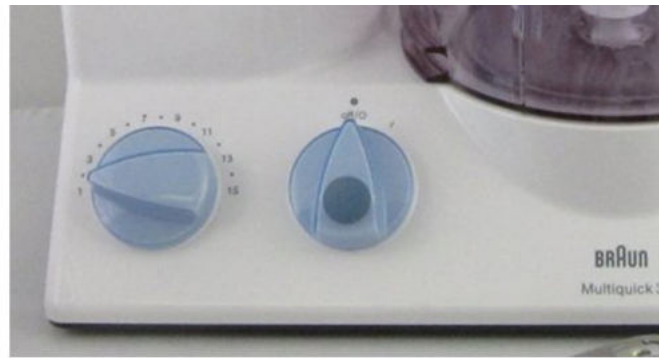

Knobs of Kitchen Appliances

## 6.12 Regulator / Control Knobs of Home Appliances

Study of regulators/control knobs on kitchen appliances and that on other home appliances is done to get an idea about the size, location and form of the knobs. The appliances studied have manual control knobs.

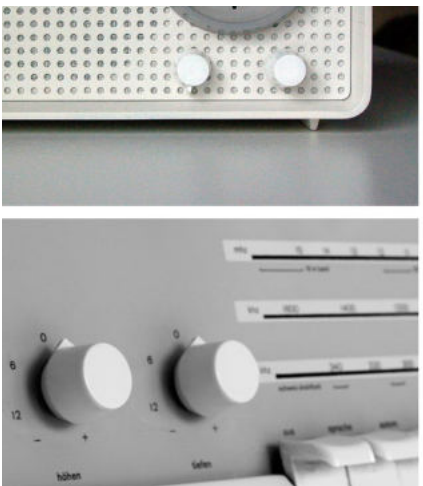

Knobs of Home Appliances

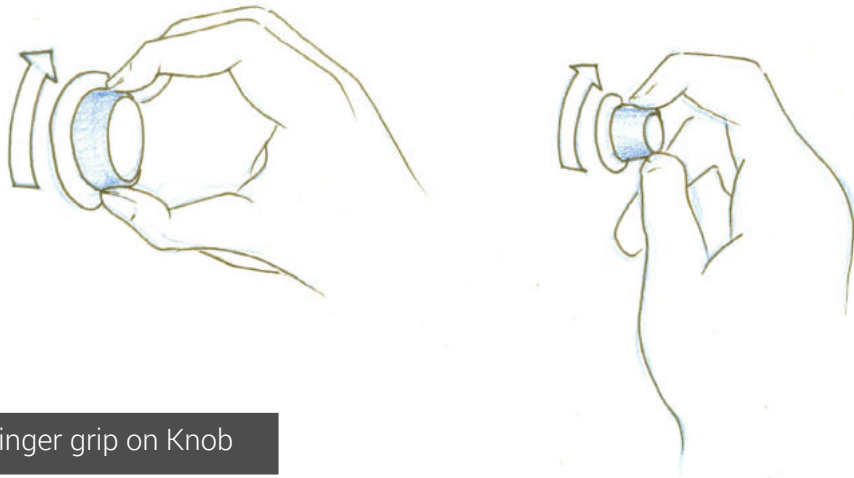

Finger grip on Knob

### 6.13 Finger Grip on the Knob

The knobs on kitchen appliances are generally bigger. Other home appliances have big or small knobs. Small knobs can be operated with two fingers, thumb and index finger while big knobs are operated three fingers.

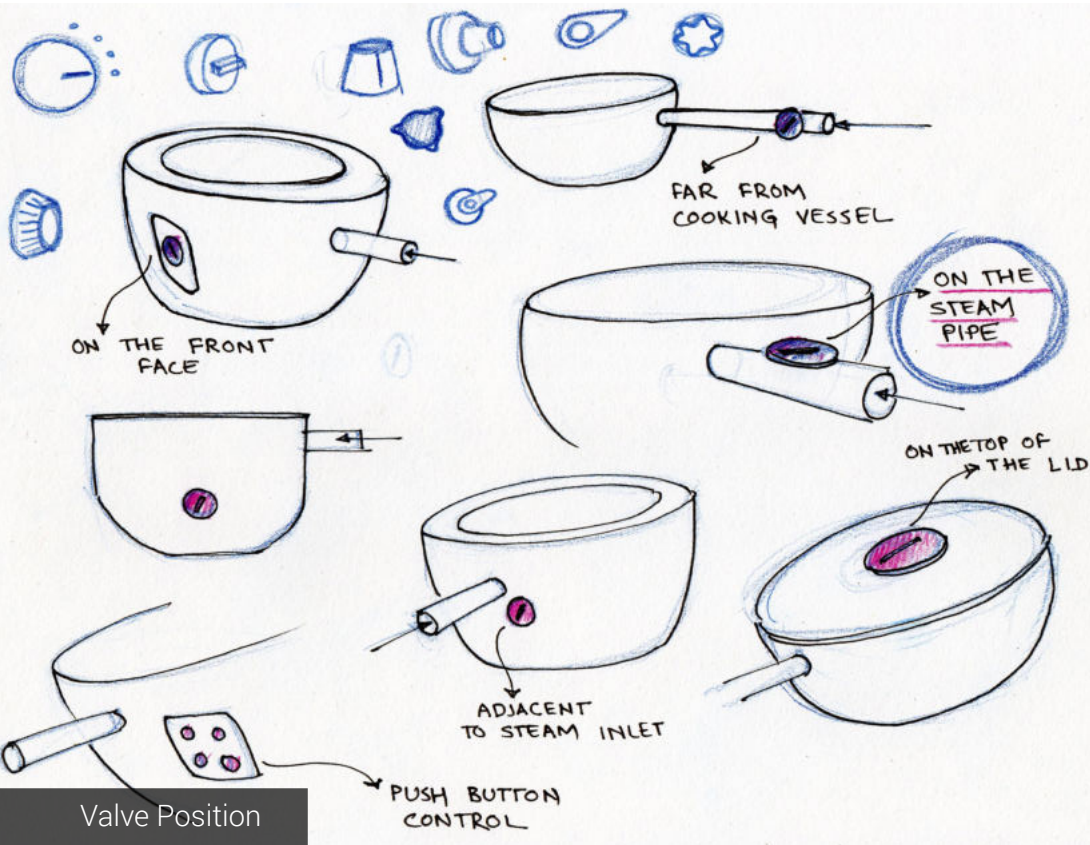

Valve Position

### 6.14 Position of Control Knob on Cookware

Explorations are done for deciding the position of control knob on the cookware. As the steam control will be done by manual valve, the valve has to be placed on the steam pipe and the control knob has to be on the same pipe directly regulating valve opening. Placing knob elsewhere on the cookware will require electric circuit to control valve opening and closing.

### 6.15 Direct Analogy - Salt Container as Steam Valve

Problem/ Challenge - Coming up with new ideas for steam control valve

Object inside the problem context : Steam Control Valve

Object outside the problem context : Salt Container

Connection : They both have control over the flow/ quantity of material

Idea : Control valve with operating mechanism of a salt container

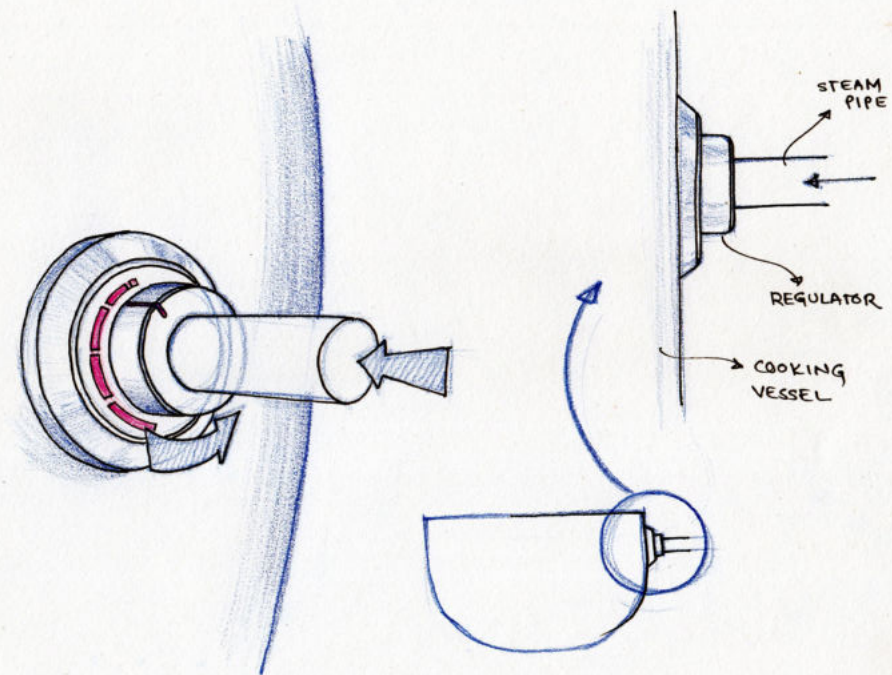
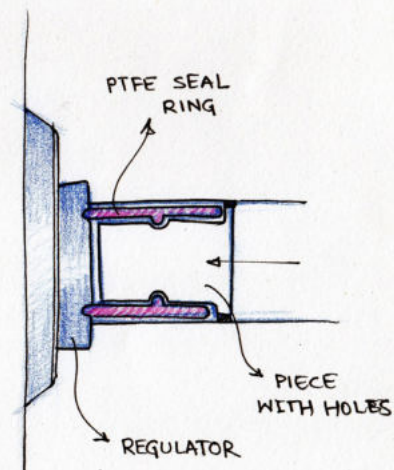
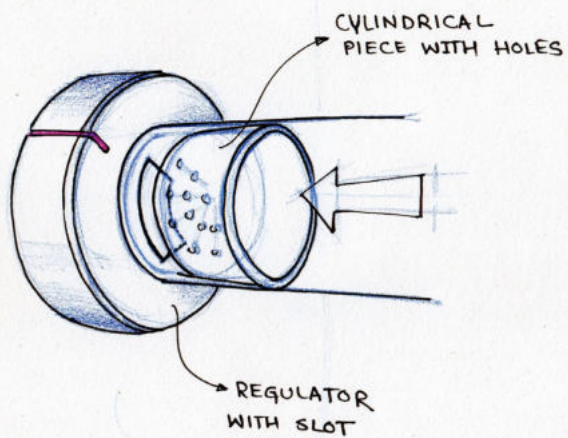
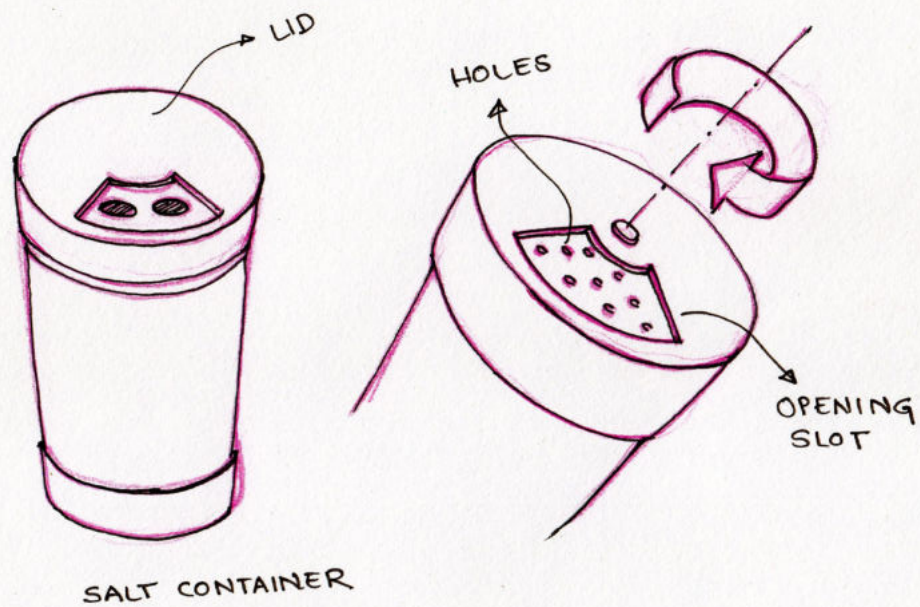

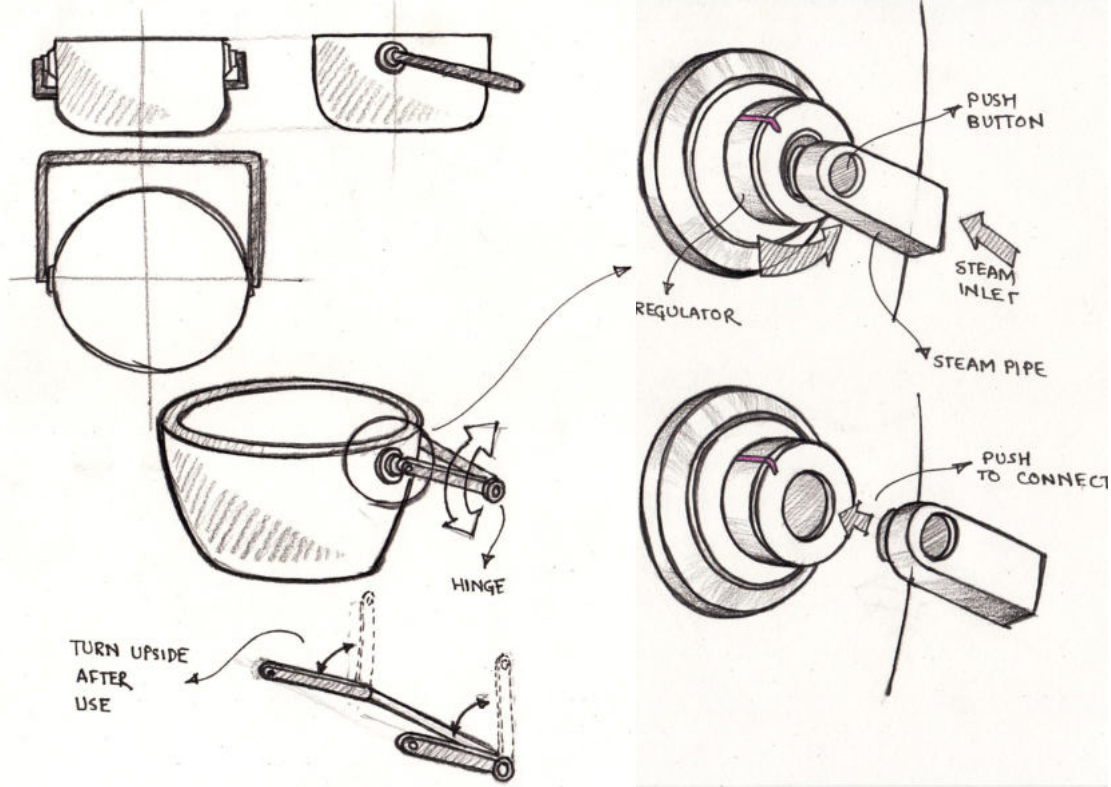

### Detailing

The jacket is joined to the steam pipe with the help of push button quick release coupling. While attaching the jacket to the pipe, the user just need to place the jacket at the location and it gets attached to the pipe.

from the pipe. This type of arrangement helps user to detach jacket easily and quickly. Also the position of hands is such that jacket does not fall on the kitchen counter.

While removing the jacket from the pipe, user needs to hold the jacket as shown in the adjacent sketch and push the button with index fingers so that it is released

Knob can be operated in ways shown in following sketches.

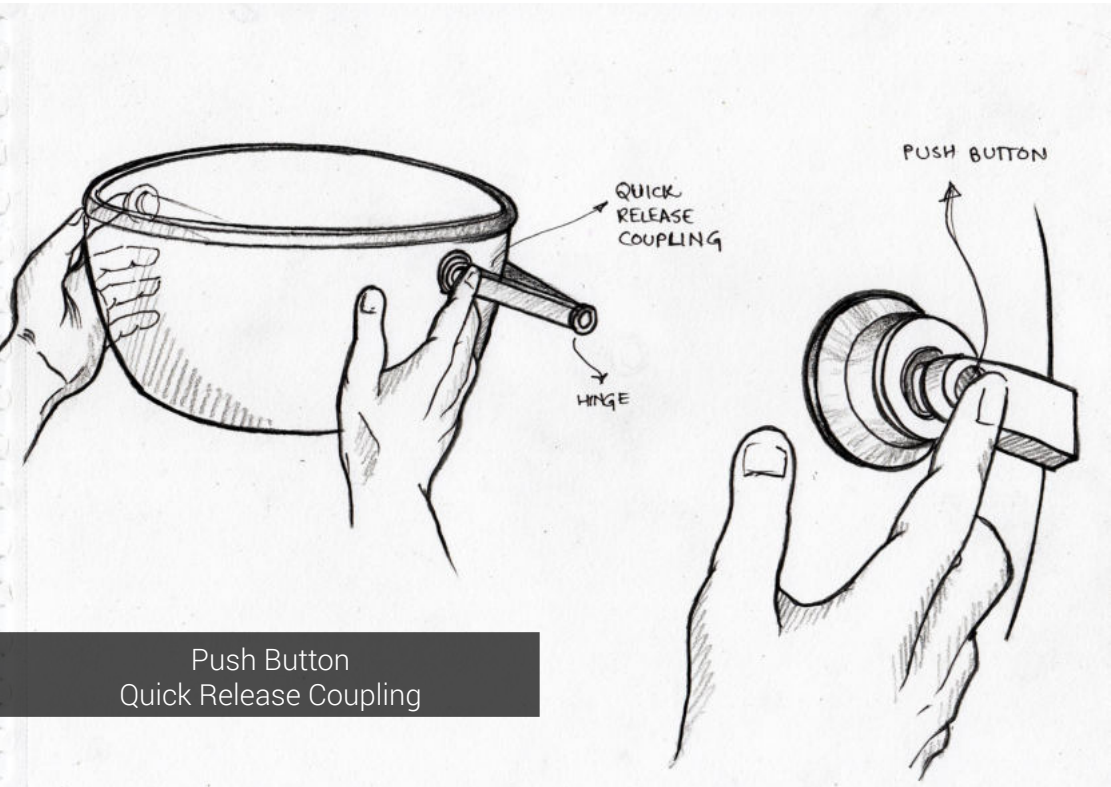

Push Button Quick Release Coupling

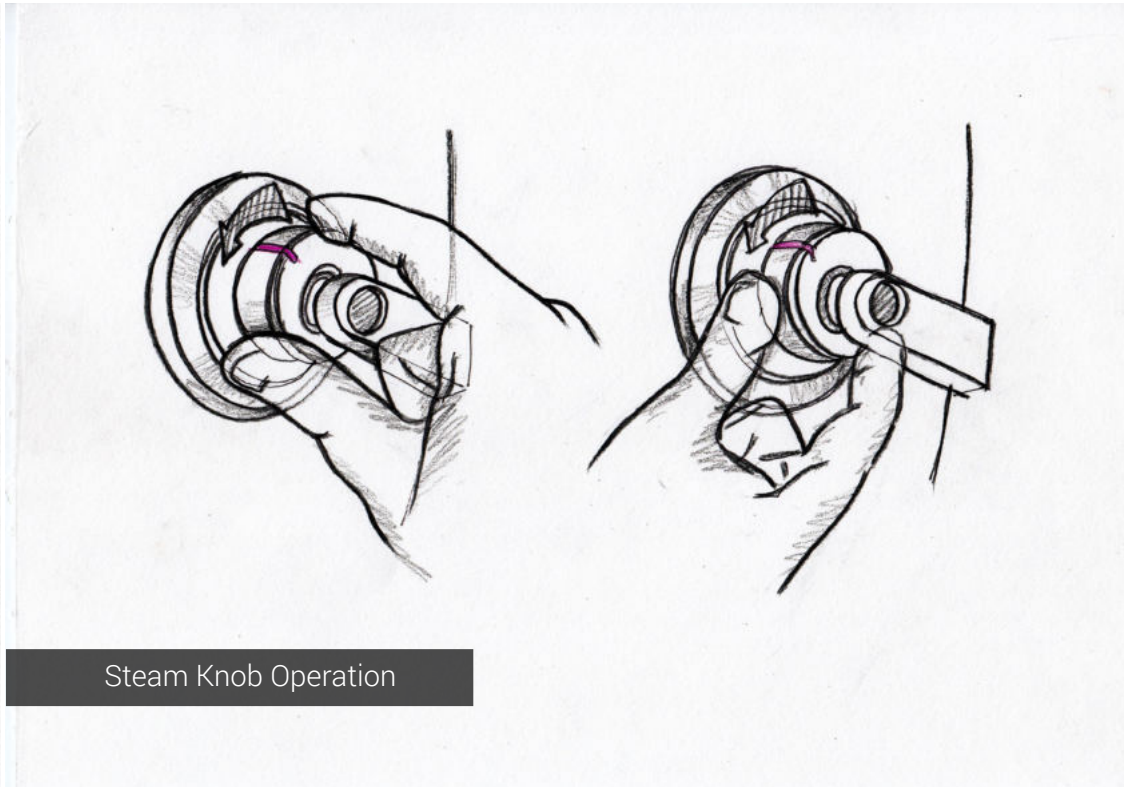

Steam Knob Operation

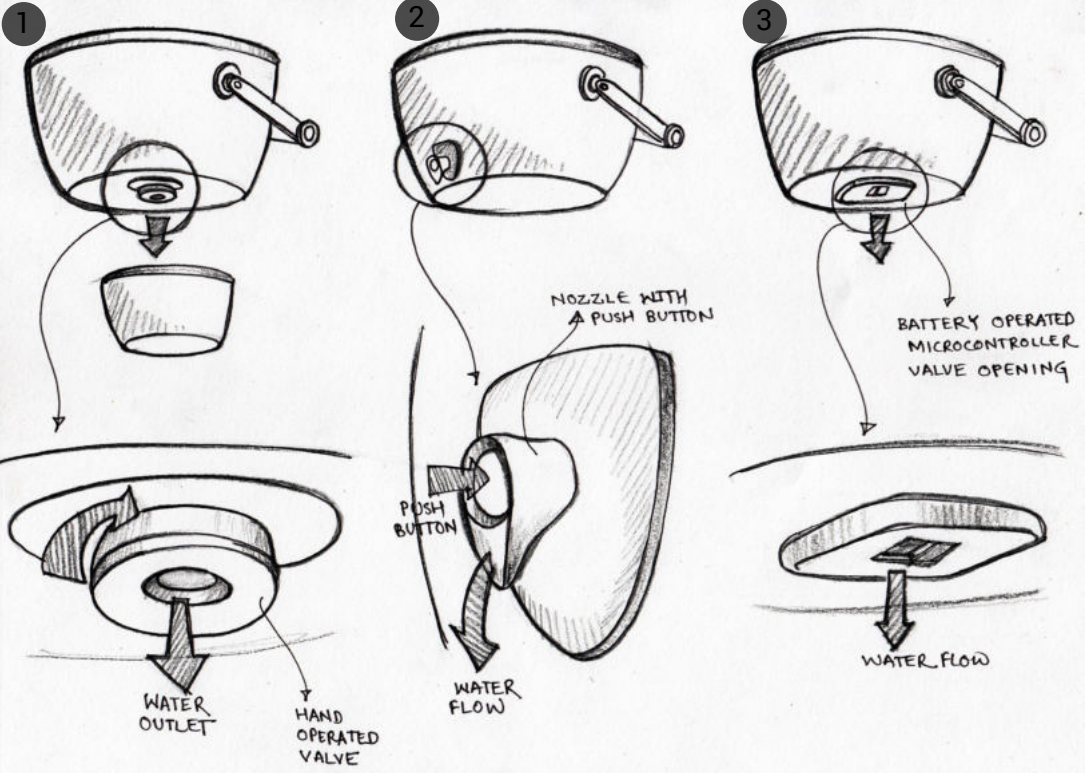

### 6.16 Water Drain Valve

Steam on condensation forms water inside the jacket. This water gets collected at the bottom of the jacket and needs to be drained out each time.

Various ways to drain the hot water are explored as shown in the sketches.

1. Manual Valve at the bottom of the jacket

In this, a similar valve as that of steam inlet valve is attached at the bottom of the jacket which is opened and closed manually by the user to drain the water.

2. Push button Nozzle

A nozzle similar to the nozzle on thermos flask is provided on the jacket. User needs to press the button to drain water through nozzle.

3. Micro-controller operated  
A battery operated micro-controller senses the water

level inside the jacket and opens the valve to release accumulated water.

4. Float operated Valve

A small float of heat resistant plastic is kept in a small chamber at the bottom of the jacket. The chamber has holes to allow water to get inside. As soon as the water level goes above a specific point, the float is lifted up from the seat and water is automatically drained out.

The density of float is maintained in such a way that it floats on water after a certain level on water is attained inside the jacket.

Out of the four options, the fourth one selected because user does not need to monitor the water level and manually open or close the valve.

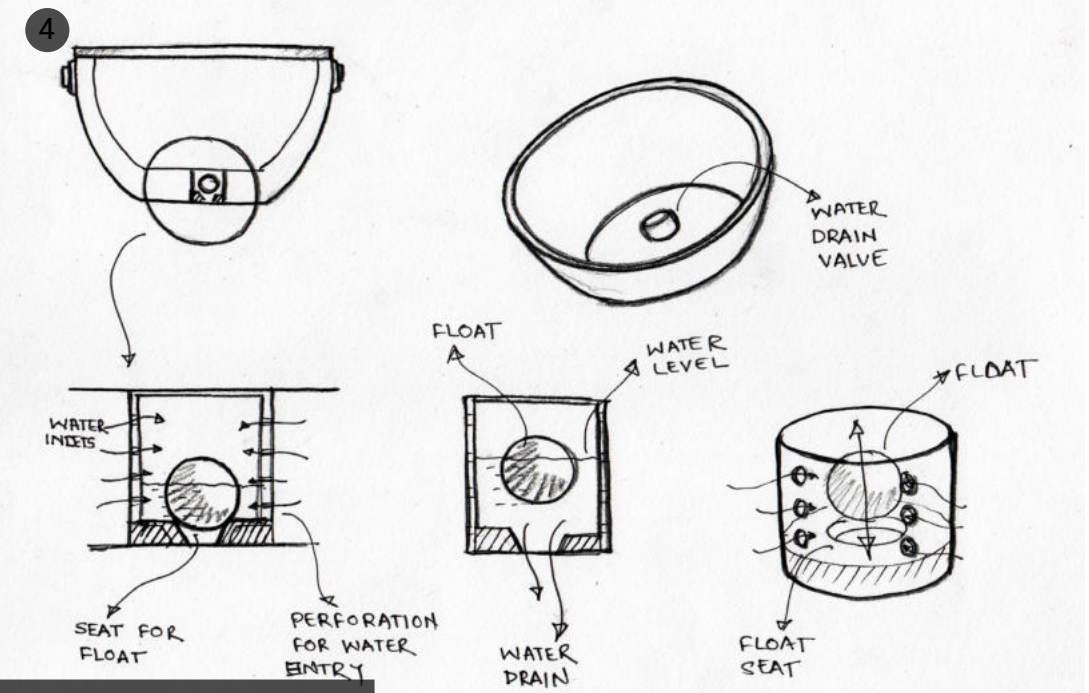

Water Drain Valve

1

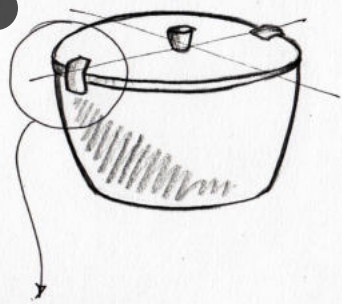

2

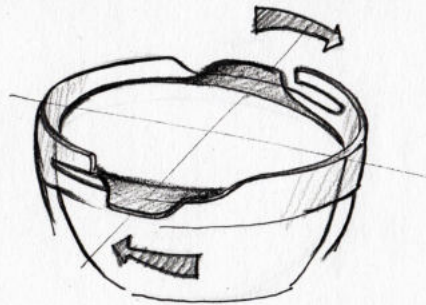
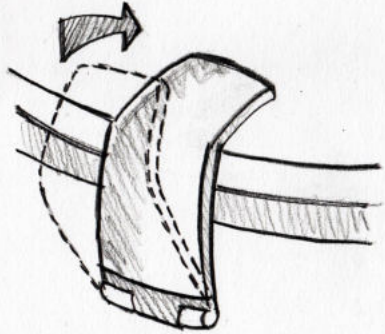
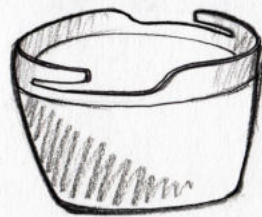

3

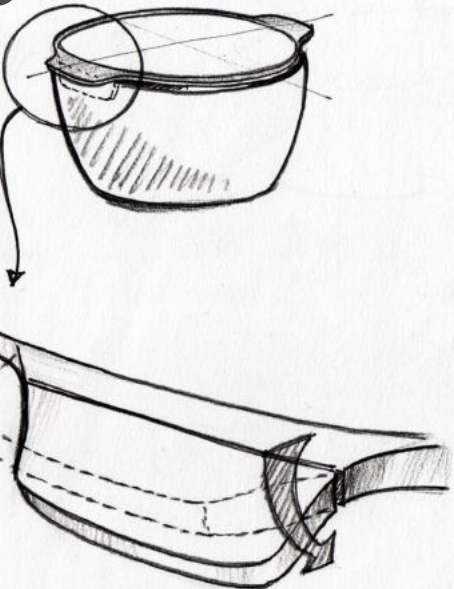

4

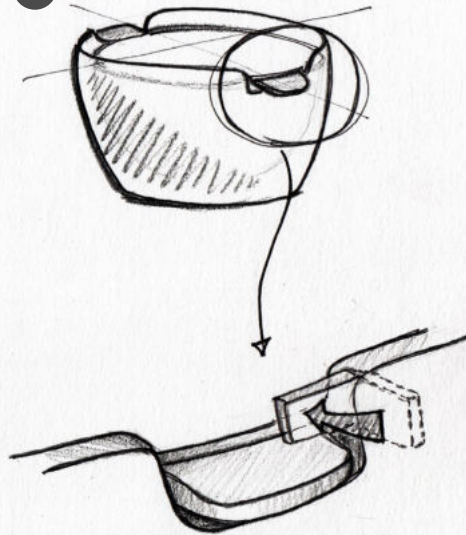

## 6.17 Locking Mechanism

Locking options explored are as follows

1. Hinge Clip to lock the lid and rice container
2. Cut-out to lock handles of rice container
3. Handle of rice container moving down for locking with the jacket
4. Hinge lock in jacket

Option 2 is selected as it involve a simple change in form to secure rice container easily by turning. The operation of locking is more intuitive in this type of arrangement. Polycarbonate is the material used for jacket. Thickness is increased at the cut out portion to protect it from breakage.

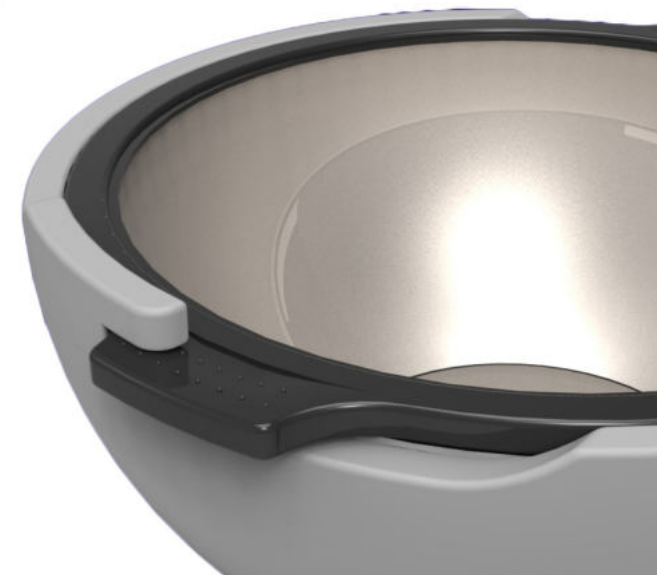



### 6.18 Form Explorations

Overall outer form of the product is explored taking inspiration from mood board and set of keywords. A few CAD models are made for lids as well as for the overall product to have better visualization of the product.



Form explorations

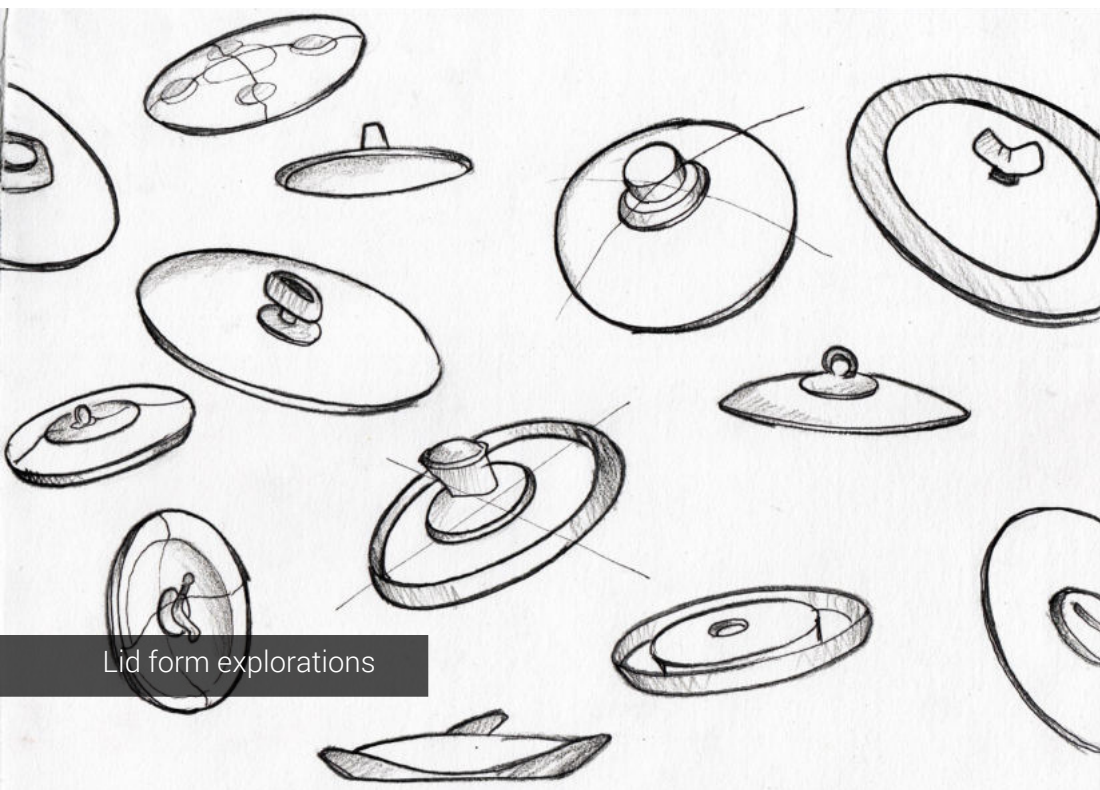
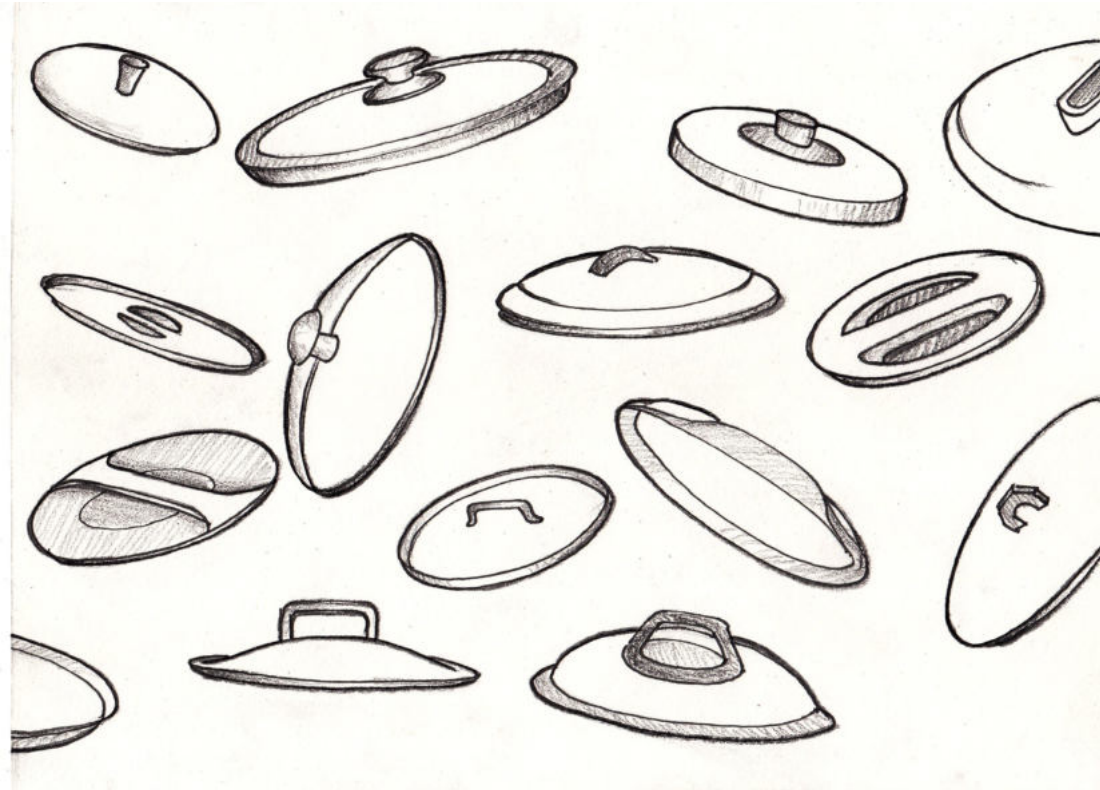

Lid form explorations

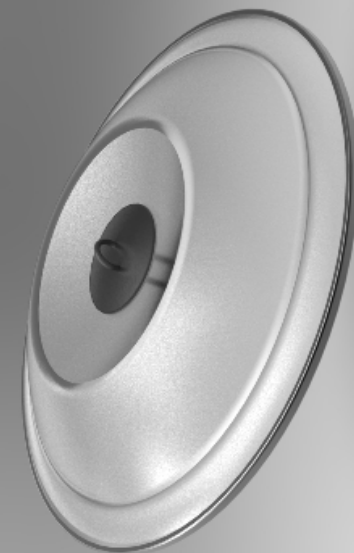
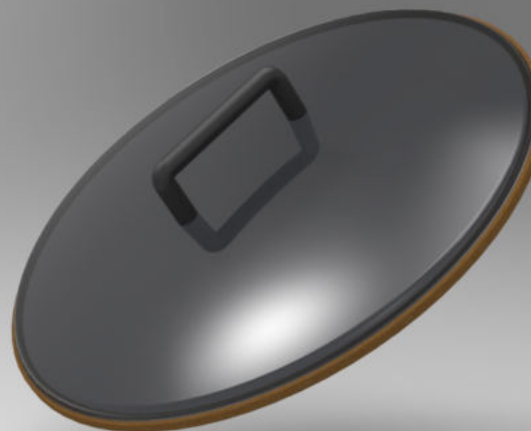
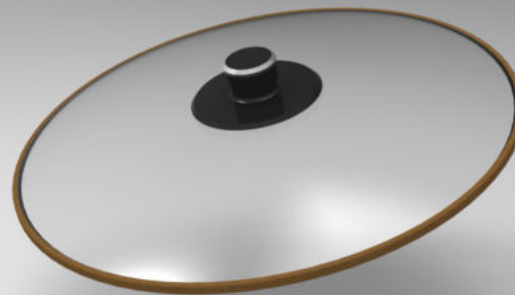
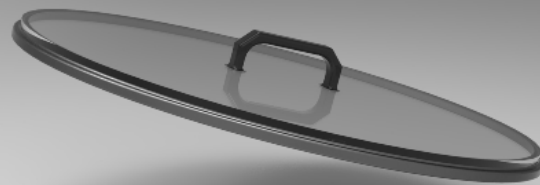

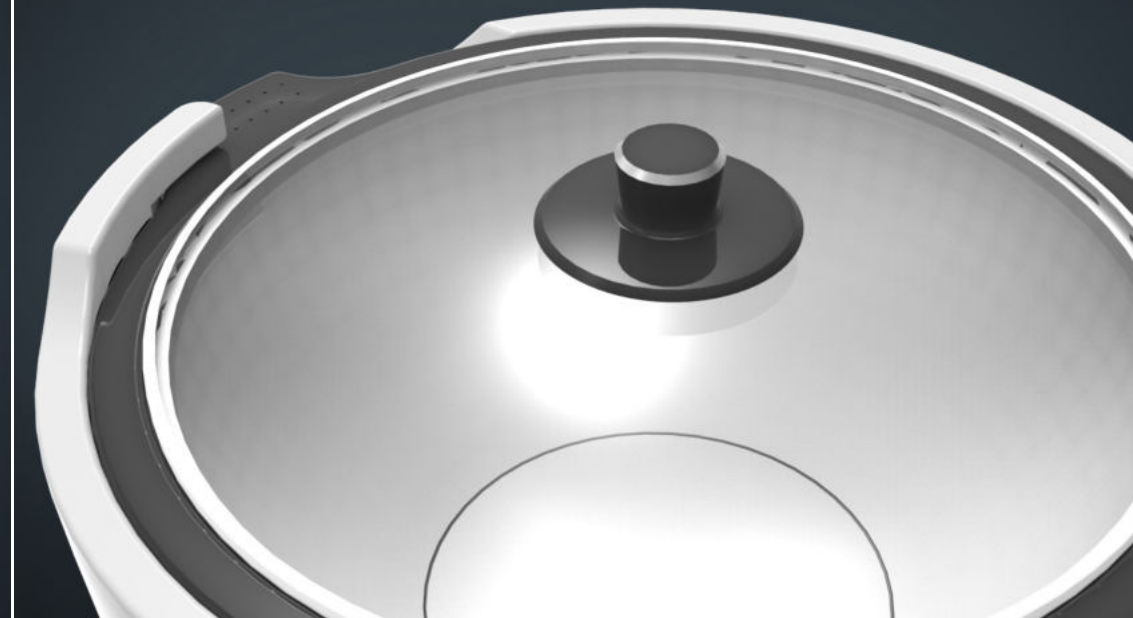
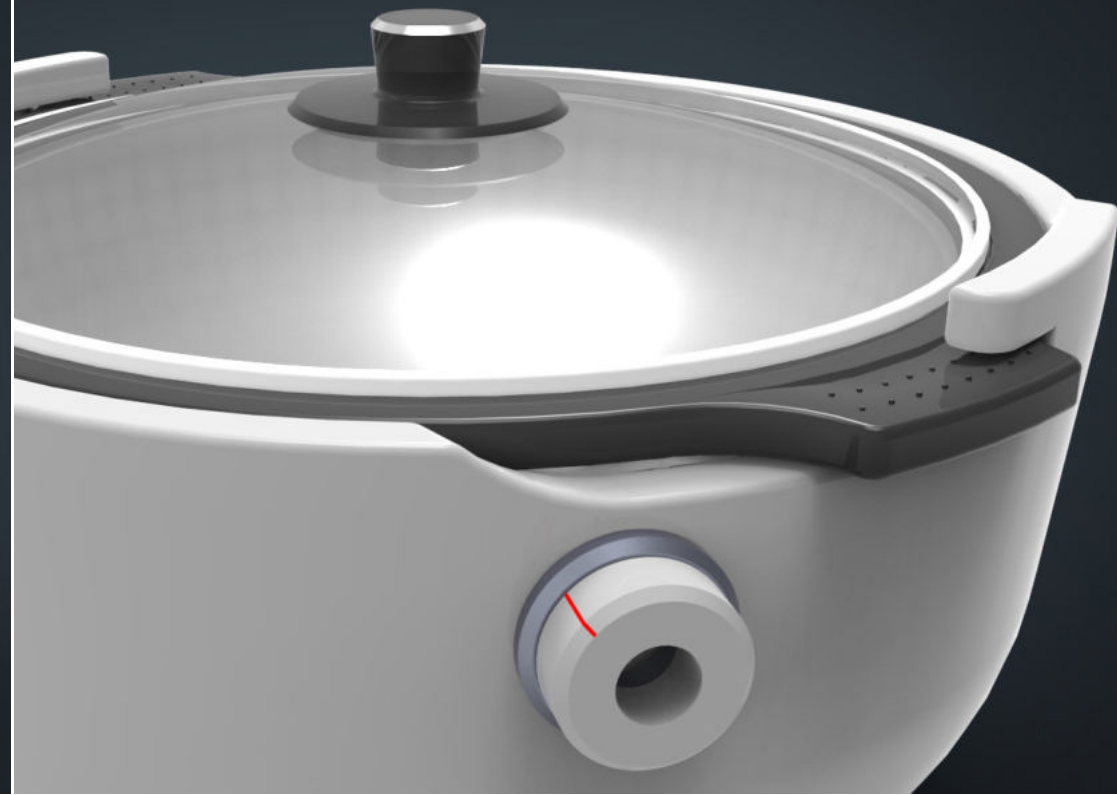

A few CAD renders



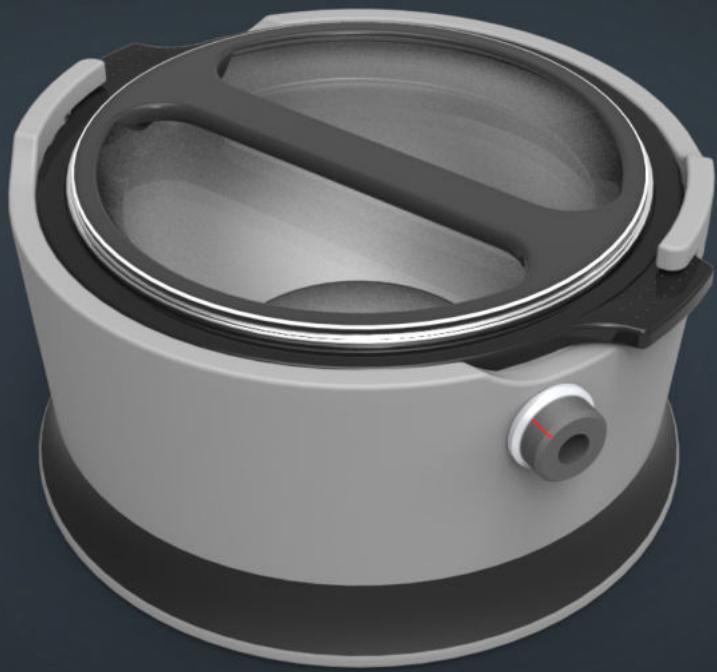



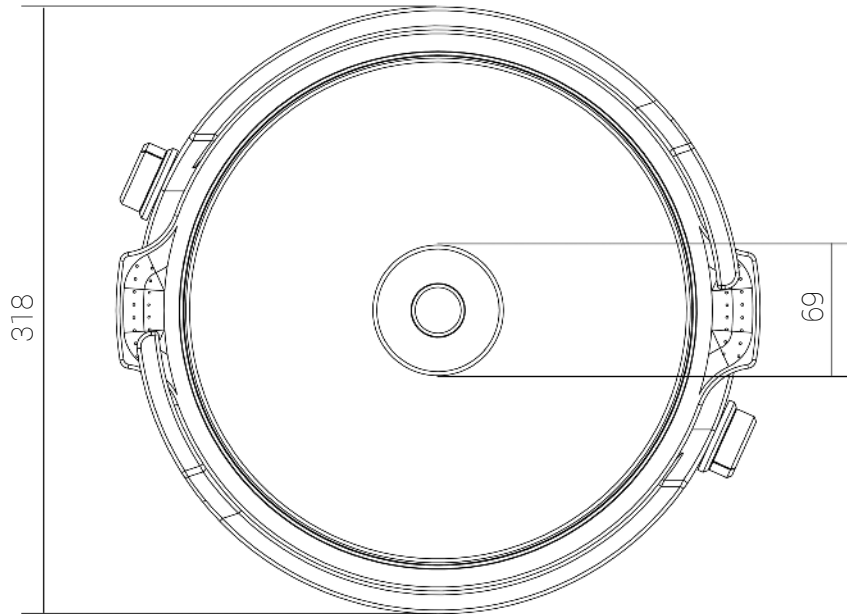
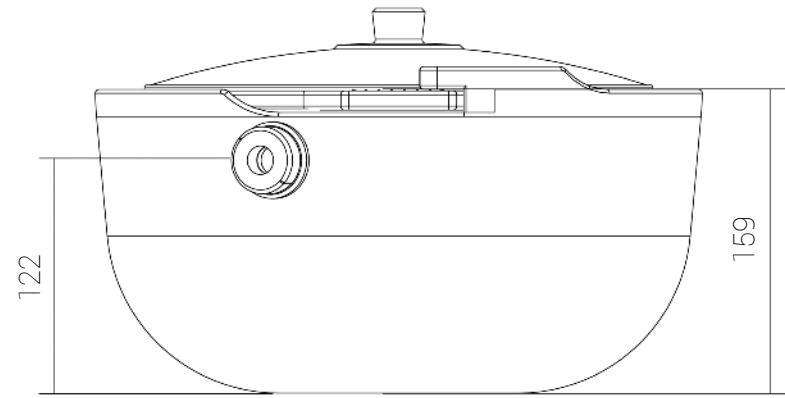
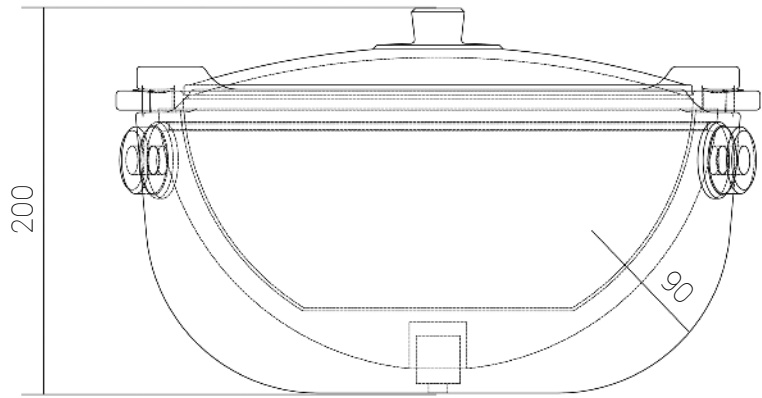

Overall Dimensional Drawing  
of selected form



Exploded View

## 7 The Crafting

---

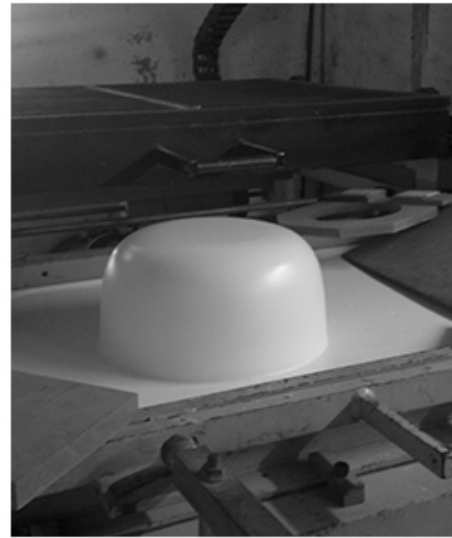
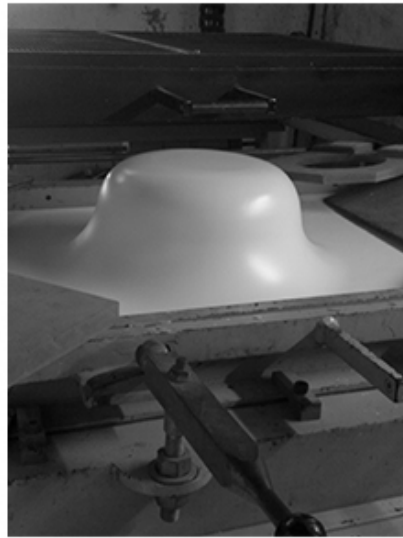
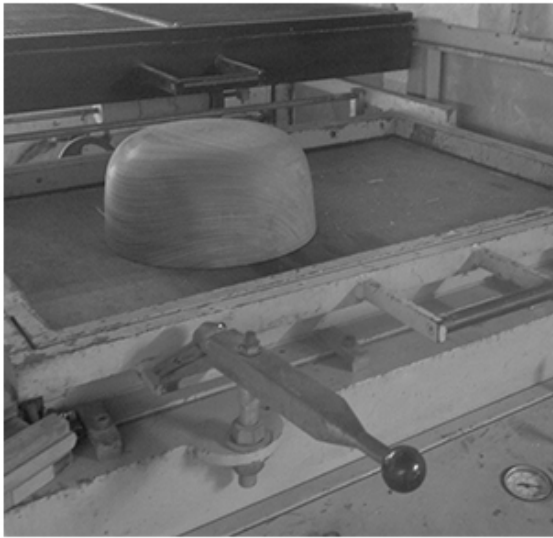









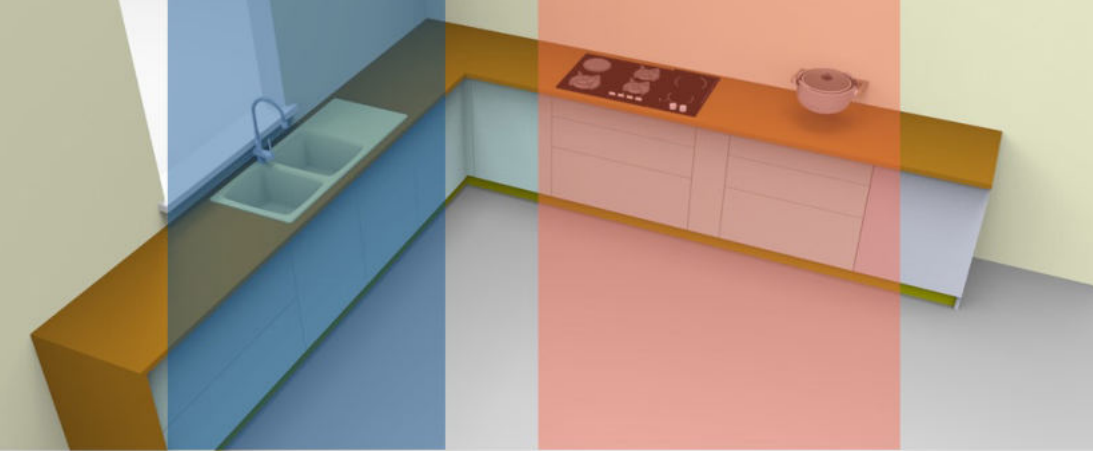

Cleaning Zone

Cooking Zone



## 8 The Connection

---

### 8.1 Position and Location of the product inside kitchen

The product will be positioned in the cooking zone of kitchen. The location of the product in a standard L shaped kitchen setup is as shown alongside.

# SOLAR STEAM COOKWARE

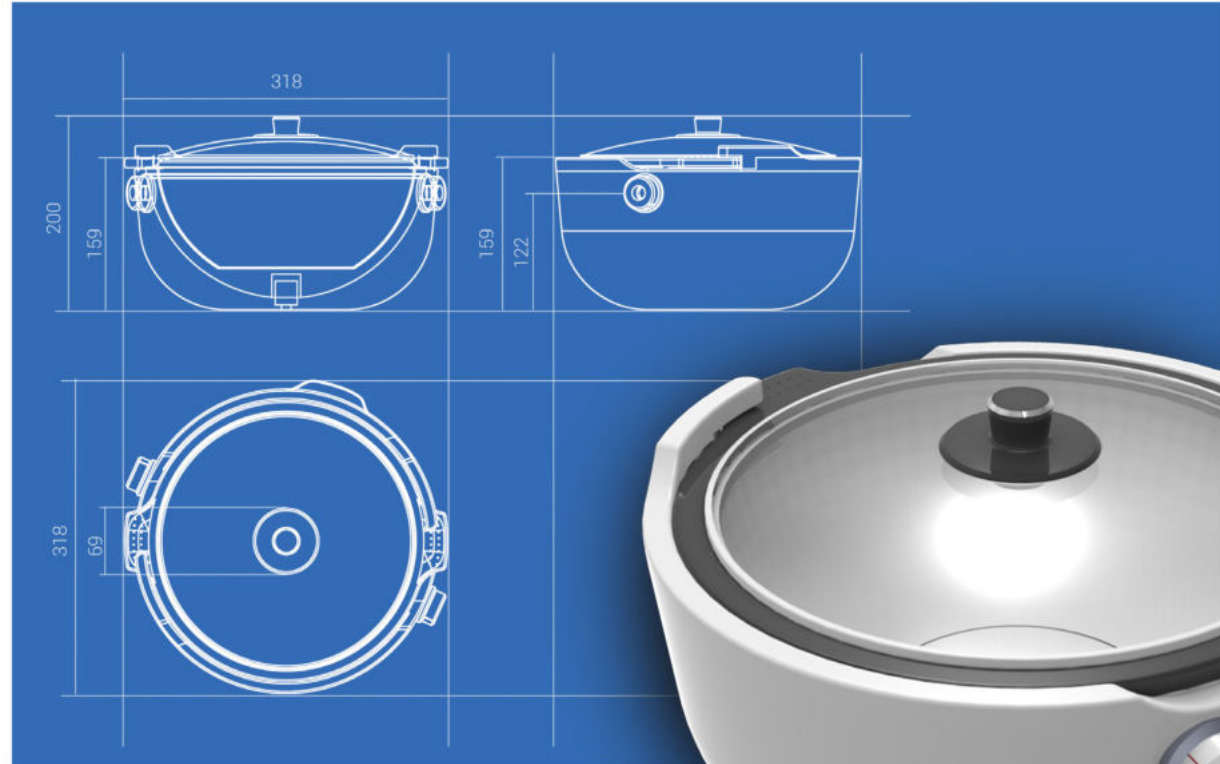
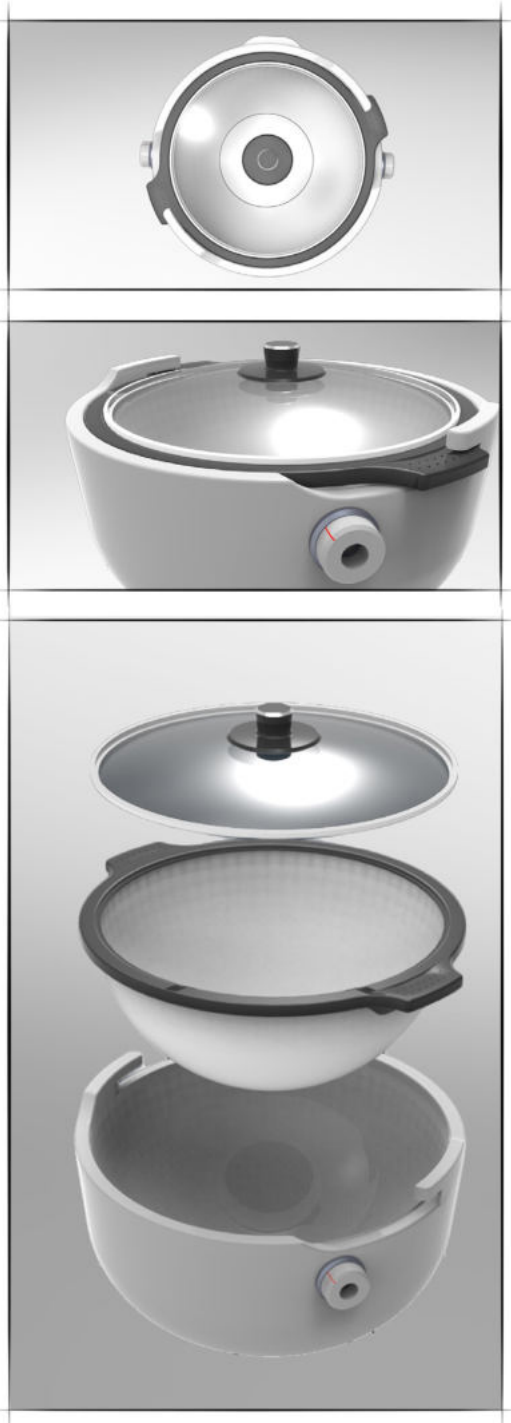

# SUSTAINABLE INDOOR COOKING

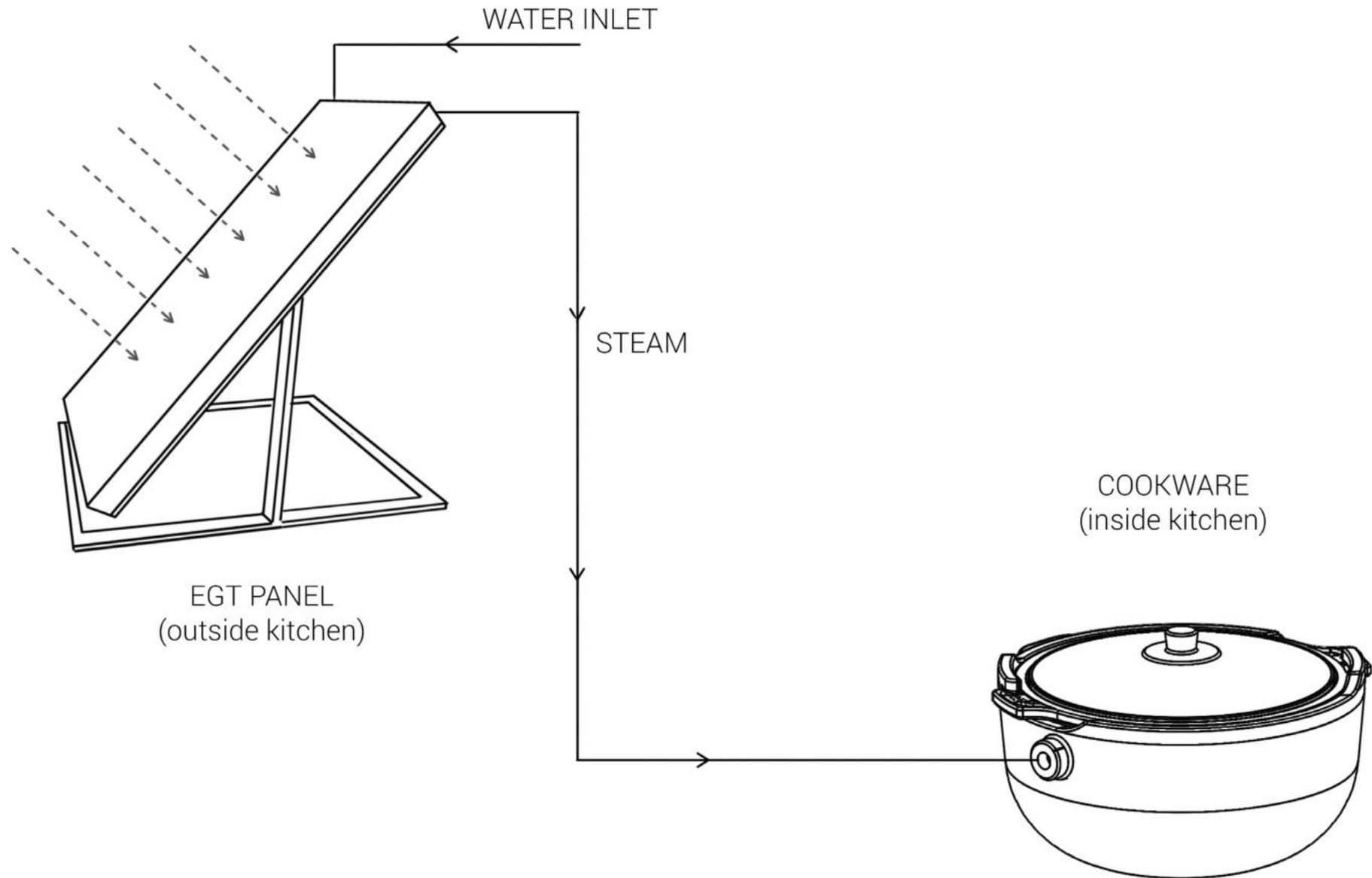



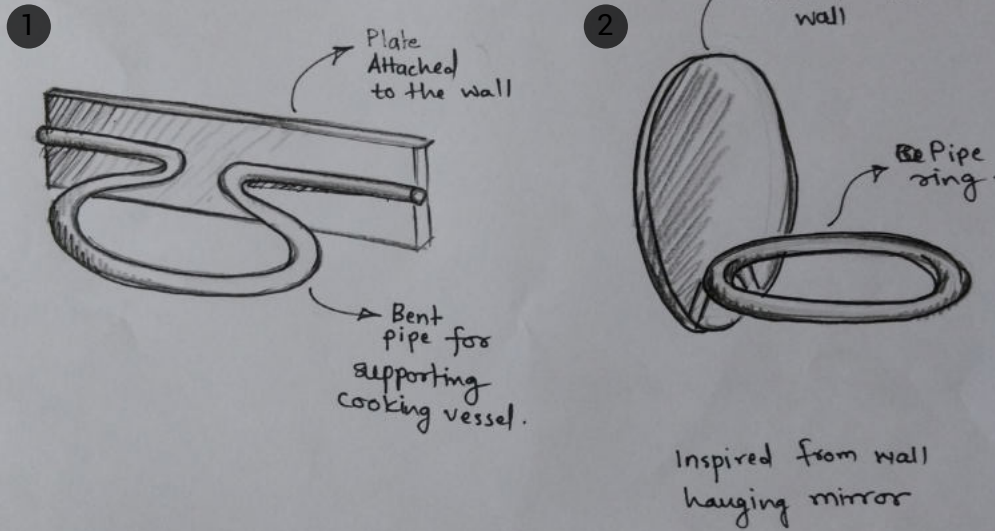

## 8.2 Necessary Changes After Final Stage Presentation

According to the suggestions by jury members during the final stage presentation, the steam inlet to the cookware needed to be detailed out. A few different variations of the steam inlet and support structure were explored as shown in the sketches beside.

A wall mounted metal plate and a bent pipe as shown in the sketch 1 can be used as a support from the wall for the cookware. Another concept which was inspired from a wall hanging mirror uses a pipe ring for structural support as shown in sketch 2.

An L-shaped steam station with steam inlet pipes can be collapsed when not in use so that the kitchen counter top can be free for another use. Sketch 4 shows a simple collapsible bar mechanism used to support the cookware.

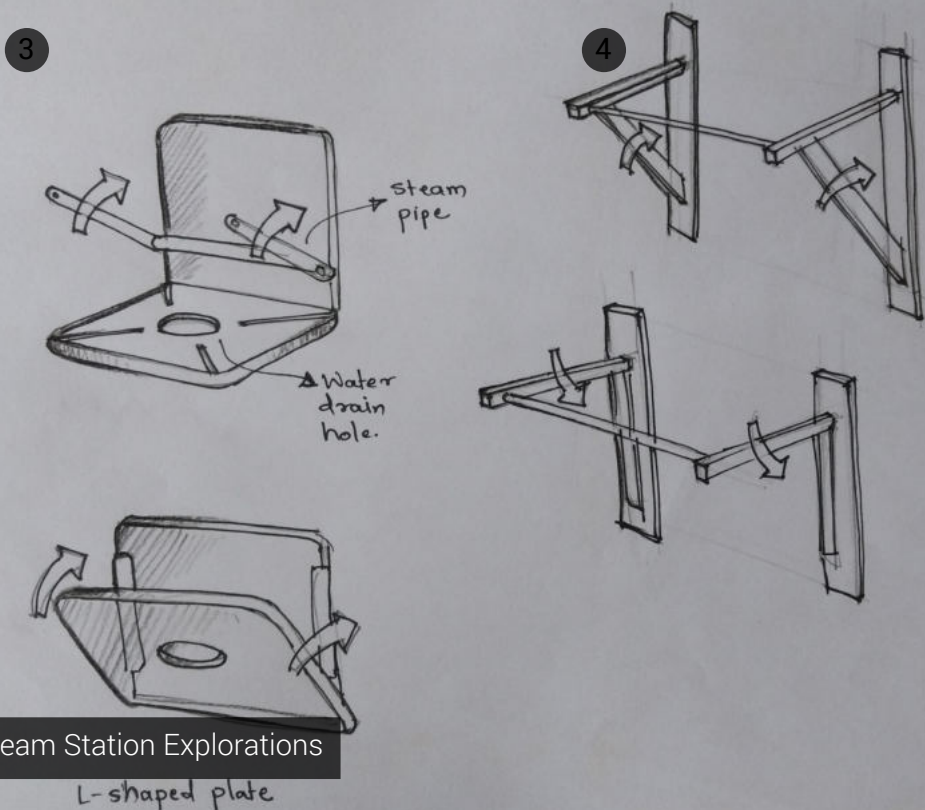

Out of the four, concept 3 is selected and detailed out further.

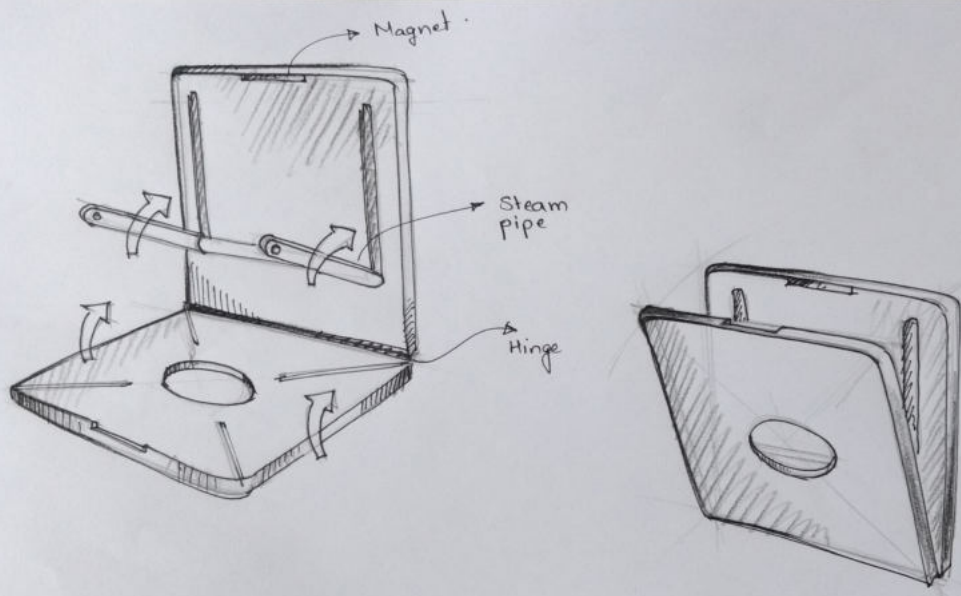

L-shaped Steam Station

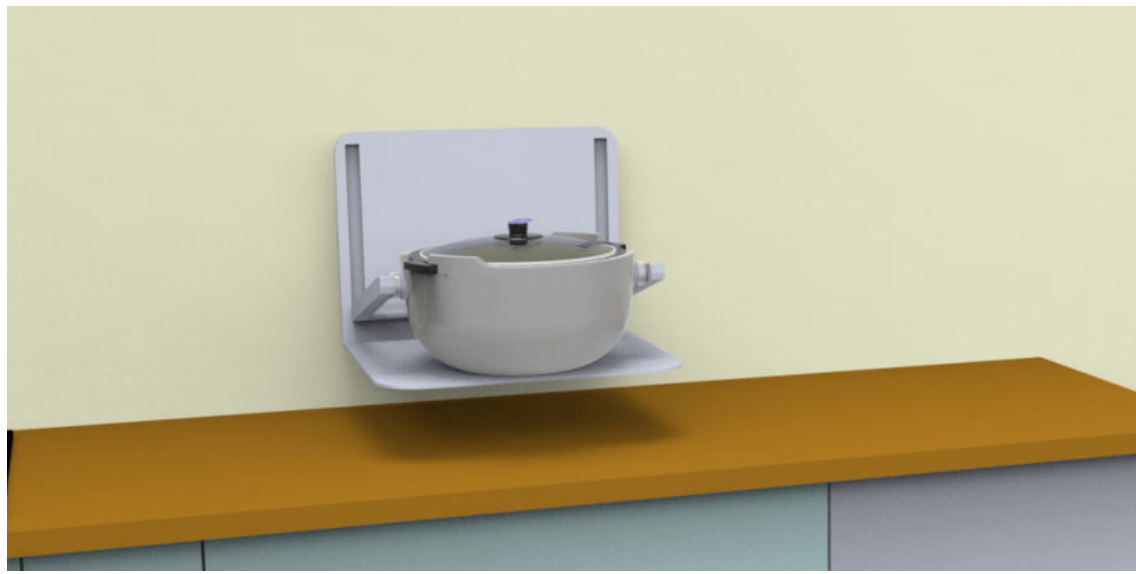
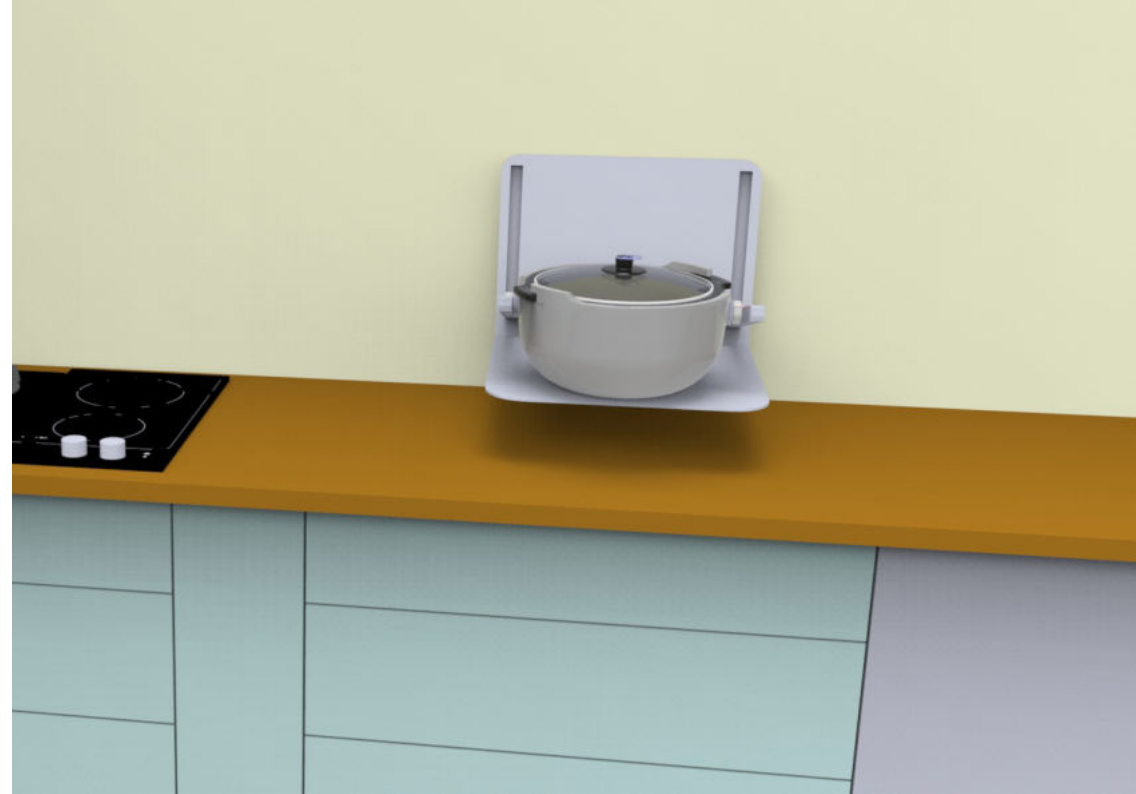

Steam station and cookware

## 9 Key Finding

---

A few things that were learnt during the project were :

1. The need of the product and where it will be used should be well defined.
2. User feedback is essential at particular stages of the design process in order to take design decisions.
3. Usage scenario of the product needs to be as clear as possible for effective outcome.
4. Understanding the user needs and designing according to them helped in justifying the product better.

## 10 References

---

1. "The unsustainability of fossil fuel use in India" , Live Mint. Retrieved on 30 Jan 2016.
2. "Solar power in India", Wikipedia. Retrieved on 30 Jan 2016
3. "Solar Steam Generator with Absorber Integrated Storage" paper presented in 5 th International Conference on Advances in Energy Research at Indian Institute of Technology Bombay, Mumbai
4. A Textbook of Machine Design, Khurmi, R S and Gupta, J K
5. IS 2347:2006 Indian Standard- Domestic Pressure Cookers
6. IS : 4536 (Part 3) - 1987 Specification for Composite Bottom SS Cooking Utensils
7. Product Design 2, PBC international, NY
8. Design Secrets: Products, IDSA

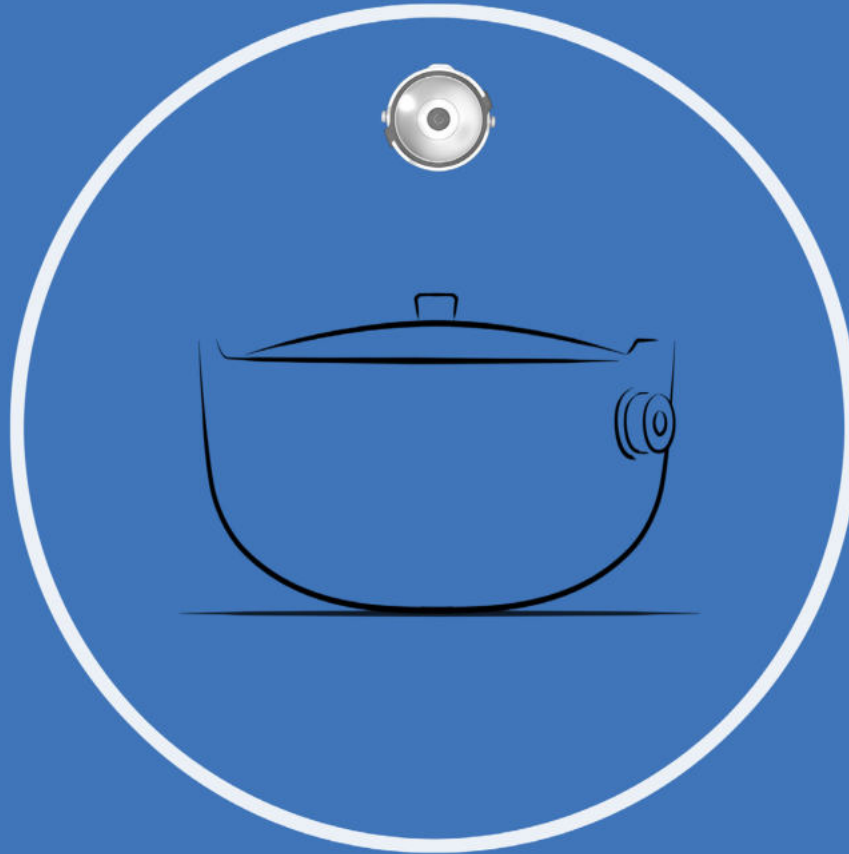

# SOLAR STEAM COOKWARE



Solar Powered



Environment Friendly



Easy To Use