Product Design Project II

REDESIGN OF INFANTRY COMBAT VEHICLE

By

Abhishek Prasad

Roll No. 076138031

Project Guide:

Prof. K. Munshi

Co-guide:

Mr. Mukesh Bopalkar

Larsen & Toubro Ltd., Powai.

Submitted in the partial fulfillment of the
requirement of the post-graduate degree of
Master of Design in Industrial Design

**INDUSTRIAL DESIGN CENTRE,
INDIAN INSTITUTE OF TECHNOLOGY, BOMBAY
January 2008**

Approval sheet

The Product Design Project II
REDESIGN OF INFANTRY COMBAT VEHICLE

By
Abhishek Prasad
Roll No. 07613803

is approved for the partial fulfillment of the requirements for
the post-graduate degree of

Master of Design in Industrial Design

At

**Industrial Design Centre,
Indian Institute Of Technology, Bombay**

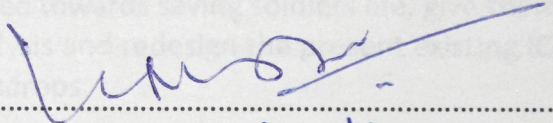
Guide.....

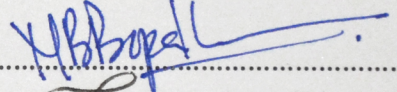
Co-guide.....

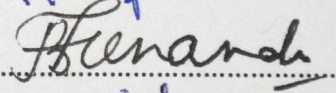
Chairperson.....

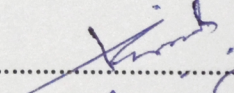
Internal examiner.....

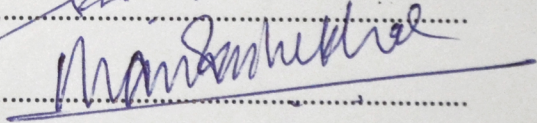
External examiner.....

Abstract

Industrial design has started to play a major role in the development of Defence Industries in past few years. India has transformed from a developing country to a fast emerging Superpower. Science and technology has also developed on a fast pace. With increase in the potential, need to safeguard the country has also increased. For the past few years the tension in the Indian Sub-continent has increased. So, the Defense is of utmost importance. Government has started many research and development programs to look into this field.

With age old Infantry Combat Vehicles (ICVs), our soldiers can't have upper edge over their enemy. For the past 30 years BMP-2 has been serving Indian Army. But with advancement in Science & Technology, Warfare scenario has changed drastically.

Need to safe guard our soldier's life and to keep their trust in the army is the main motto of this project. Having a good fighting instrument really plays a vital role in moral build-up. Project is intended towards saving soldiers life, give them better fighting power, agronomical analysis and redesign the present existing ICV in the Indian Army and solve their backdrops.

Acknowledgements

There are many people whose assistance helped me in this project and I would like to thank them all.

Firstly, I thank **Prof. K.Munshi**, my project guide, for all his time and suggestions which helped at every stage of the project. I also thank him for his initiative in making this project happen.

I want to thank my co-guide **Mr. Mukesh Bopalkar** from Larsen & Toubro Ltd. for his Guidance and support.

I would also like to thank the Dept. head **Mr. A. T. Ramchandani** for providing me the opportunity to work on such esteemed project.

My sincere thanks to Ravi & everyone at Technology & Product Development, L&T.

Many thanks to Ameya & Prajjwal who shared their time and gave me valuable inputs throughout the project.

Finally, I thank my family for their support in whatever I have done till date.

Abhishek Prasad
IDC, IIT Bombay

Index

Approval Sheet	i
Abstract	ii
Acknowledgements	li
Larsen & Toubro : An Introduction	1
1 Introduction	5
1.1 The Project Objective	5
1.2 Infantry Combat Vehicle : An Introduction	6
1.2.1 Infantry Fighting Vehicle : Main Parts	8
2 Data collection and Research	10
2.1 M113	11
2.2 Infantry Combat Vehicles : Changing Face with Time	14
2.2.1 BMP-1	15
2.2.2 World Scenario : ICVs	16
2.2.3 Infantry Combat Vehicles : Where India stands????	18
2.3 Various Aspects Of ICVs : Areas in Focus of Project	19
2.4 Introduction Of ICVs used in Indian Military : BMP2	20
2.5 Current Generation ICVs & Impact Of Technology	21
2.5.1 Technology Matrix	22
2.5.2 Current Generation ICVs & their specialties	23
2.5.3 ICVs at Glance	25
2.5.4 ICV Armament	26
2.5.5 ICV Protection	27
2.5.6 BMP-2 Armor Protection	28
2.5.7 ICV Performance - Power v/s Weight	29
2.5.8 ICV Performance - hp/ton	30
2.5.9 ICV Performance – Range	31

2.6 Types of ICV	32
2.6.1 Wheel v/s Track- A Comparison	33
2.7 New Technologies in ICVs	34
2.8 Deficiencies in ICVs	36
2.8.1 Deficiencies in Current ICVs	36
2.8.2 Deficiencies in BMP-2	37
2.8.3 Good feature of BMP-2	41
2.9 Camouflaging	42
2.9.1 Camouflaging : Mapping	43
2.9.2 Radar Signature	44
2.9.3 Thermal Signature	45
2.9.4 Acoustic Signature	46
2.9.5 Visual Signature	46
3 Project Brief	47
4 Ergonomic Analysis and Layout	48
4.1 Ergonomic Analysis	49
4.2 Abbreviations used throughout the Ergonomic Analysis	50
4.3 Ergonomic Data	52
4.4 Various Layout Plans	55
4.5 Final Layout Concept	60
4.6 Rig Testing & Changes	63
5 Aesthetic & Styling	65
5.1 Aesthetic	66
5.2 Mood Board	67
5.3 Elements of Mood Board	68
5.4 Concept Sketching & Ideas	69
5.5 Selection of Best Concept	74
5.6 Exploration & Mock-up Models	75
5.7 Final Concept Development	76
5.8 Designing of the Turret	77
5.9 Final ICV Rendering	78

6 New Features to the Design	79
6.1 Fuel Tank Placement & Crew Safety	79
6.2 Unmanned Turret	81
6.3 Use Of Automatic Machine Guns	82
6.4 Sloping Armor	84
6.5 Instructions Inside the ICV	85
6.6 Harness	86
6.7 Use of Better Paint	87
6.8 Use of Reactive Armours	87
6.9 Control Panel	87
6.10 Cooling of the Crew Compartment	88
6.11 Crew Seating	89
6.12 Emergency Hatch	90
7 Learning	91
References	92



Larsen & Toubro : An Introduction

L&T was founded in Bombay (Mumbai) in 1938 by two Danish engineers, Henning Holck-Larsen and Soren Kristian Toubro. Both of them were strongly committed to developing India's engineering capabilities to meet the demands of industry.

Beginning with the import of machinery from Europe, L&T rapidly took on engineering and construction assignments of increasing sophistication. Today, the company sets global engineering benchmarks in terms of scale and complexity.

Larsen & Toubro (L&T), headquartered in Mumbai (Maharashtra) is a technology-driven engineering and construction organisation and one of the largest companies in India's private sector. It has further interests in manufacturing, services and Information Technology. The evolution of L&T into the country's largest engineering and construction organization is among the most remarkable success stories in Indian industry.

Larsen & Toubro Limited (L&T) is a technology, engineering, construction and manufacturing company. It is one of the largest and most respected companies in India's private sector. Seven decades of a strong, customer-focused approach and the continuous quest for world-class quality have enabled it to attain and sustain leadership in all its major lines of business. L&T has an international presence, with a global spread of offices. A thrust on international business has seen overseas earnings grow significantly. It continues to grow its overseas manufacturing footprint, with facilities in



China and the Gulf region. The company's businesses are supported by a wide marketing and distribution network, and have established a reputation for strong customer support. L&T believes that progress must be achieved in harmony with the environment. A commitment to community welfare and environmental protection are an integral part of the corporate vision.

A strong, customer-focused approach and the constant quest for top-class quality have enabled the company to attain and sustain leadership in its major lines of business. It has established an international presence, with a global spread of offices. A thrust on international business across the last few years has seen overseas earnings growing to 18 per cent of total revenue. With factories and offices located around the country, further supplemented by a comprehensive marketing and distribution network, L&T enjoys an image and equity in virtually every district of India. Its signature of excellence is evident on several projects:

- The world's largest Continuous Catalyst Reactor
- World's largest Tubular Reactor for a petrochemical plant
- The world's largest Fluid Catalytic Cracking Regenerator
- The world's longest Product Splitter
- The world's longest LPG pipeline
- Asia's highest Viaduct
- The first to offer electrical distribution products & systems engineered for tropical environments
- India's first indigenous Hydrocracker Reactor
- India's first open sea jetty
- India's biggest Offshore Oil Platform
- India's longest Coal Conveyor
- India's widest range of Low Tension Electrical Switchgear

-
- World's longest gas pipeline
 - World's longest coal conveyor
 - Building an international class football stadium in 260 days
 - World's largest coal gasifier made in India and exported to China



Operating Divisions:

- Engineering & Construction Projects (E&C)
- Heavy Engineering (HED)
- Engineering Construction & Contracts (ECC)
- Electrical & Electronics (EBG)
- Machinery & Industrial Products (MIPD)
- Information Technology & Engineering Services

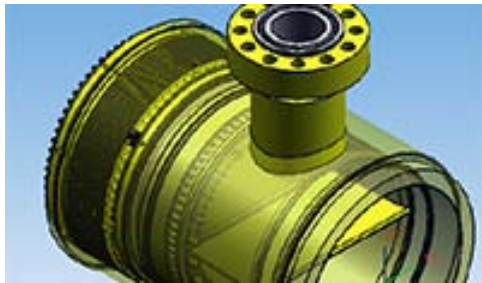

Heavy Engineering (HED):

L&T's Heavy Engineering Division has established a reputation in global markets for quality products. The Division manufactures & supplies custom designed & engineered critical equipment & systems to the needs of core-sector industries and the defense sector. It is the preferred supplier of equipment for a select range of products, globally.

L&T has state-of-the-art manufacturing facilities, which are capable of meeting the challenges of technology, quality conformance and delivery, while ensuring cost competitiveness.



The manufacturing plants are among the top fabrication facilities in the world with processes streamlined to achieve high efficiency and benchmarked to the latest technologies.

Defence: L&T has licenses for manufacture and supply of a wide range of defence products, after the Government of India's decision to open up Defence production to the private sector. The licenses issued to L&T cover design, development and construction / manufacture of warships, submarines, weapon platforms & launchers, field & air defence guns, anti tank weapon systems, missiles, rockets, torpedoes, land / naval mines including associated systems and subsystems, RADAR, SONAR, sensors, armoured and combat vehicles, airborne assemblies, systems and equipment for aircraft, helicopters and UAV, etc.

Current Product Range: Naval Marine Systems, Naval Combat Systems, Army & Air Force Products, Defense (Army, Navy & Air Force) Strategic Electronics, Complete Naval Units, Radars, Advanced Composite Products for various Defense applications.

The department: Technology & Product Development Centre (Special Projects) – This department carries out design and development activities for projects in the Defense, Nuclear Power, and Aerospace sectors. All kind of design (2D, 3D and analysis of the design) is accomplished at this centre that is well equipped with a range of software and prototyping facilities. The department works closely with the Defense Electronics Department in the development of multi-disciplinary defence systems.

1. Introduction :

1.1 The Project Objective:

The Project aims at redesigning the BMP-2 ICVs present currently in the Indian Army and to achieve a perfect balance between appearance, function and safety of the crew.

1.2 Infantry Combat Vehicle : An Introduction

An Infantry Combat Vehicle (ICV) also known as Mechanized Infantry Fighting Vehicle (MIFV) is a type of Armoured Fighting Vehicle (AFV) used to carry infantry into battle and provide fire support for them.

Tracked or Wheeled ICVs are designed to fight as part of an armoured battle group i.e. with tanks. It is armed with a quick-firing cannon and one or more machine guns.





-ICVs are similar to Armored Personnel Carriers (APCs).

-Designed to transport five to ten infantrymen and give direct-fire support during an assault.

-Typically armed with an Autocannon of 20 to 40mm caliber, 7.62mm machine guns and possibly with ATGMs .

-Generally much less armoured than main battle tanks (MBTs).

-Sometimes carry missiles, such as the NATO TOW missile and Soviet Spigot which offer a significant threat to tanks.



1.2.1 INFANTARY COMBAT VEHICLE : Main Parts

Armour and countermeasures

- ICVs have thinner and less complex armour than tanks to ensure easy mobility
- Proof against heavy machine guns, artillery fragments, and small arms
- Anti-tank duties in emergencies or in support of tank units
- Carry riflemen and their weapons into the battlefield
- The vehicle to be tailored for particular missions
- The most common counter measures are smoke grenade dischargers, help IFVs to avoid a hits from ATGMs by allowing the IFV to hide behind a smoke screen.

Main armament

- The primary weapon on most ICVs is an Autocannon, usually of a calibre between 20 and 40mm
- Fire several types of munitions, including high explosive, incendiary, and kinetic penetrator rounds
- Germany's Puma (IFV) can fire Air Burst Munition (ABM) Carry

Coaxial Machine guns

- On all IFVs, a coaxial machine gun is mounted on the turret along with the main armament
 - Most common calibre is 7.62mm
- Some ICVs mount more than one machine guns

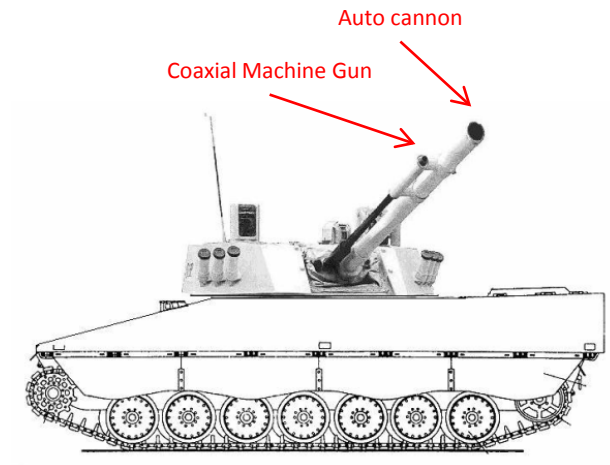

Missiles

Some IFVs are equipped with anti-tank guided missiles

These missiles are mostly medium range (2000-4000 m)

Surface-to-air missiles or a combination of the two (2T Stalker)

Grenade launchers

Some new vehicles, such as the Puma, come equipped with 30, 40 or 76 mm grenade launchers. All IFVs also have smoke grenade dischargers for concealment.

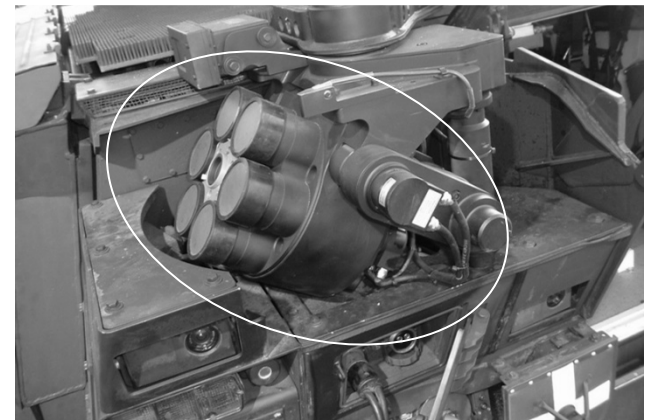
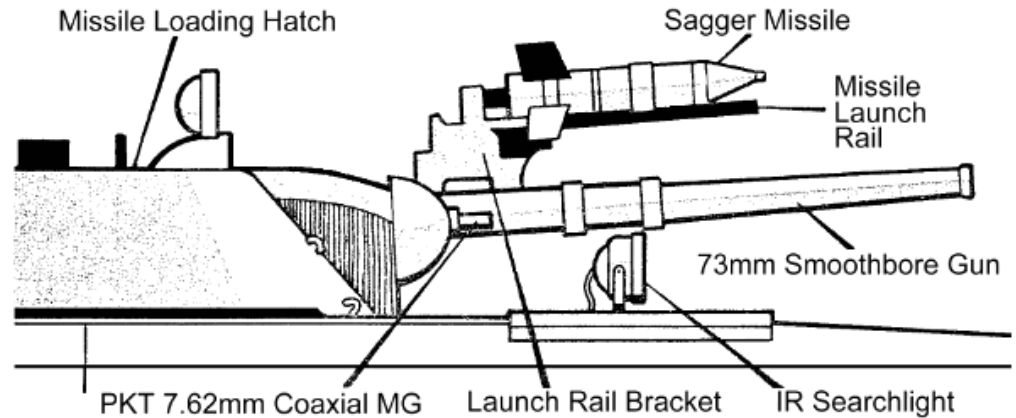

2 Data Collection & Research

2.1 **M113** was first to be used as ICV



M113 was designed as an APC, it was among the first to be used in the early 1960s as an ICV when South Vietnam ARVN troops fought while mounted against infantry which lacked effective antitank weapons. After the Battle of Ap Bac (1958–1975) showed that the exposed machine gun was vulnerable to enemy fire, they were fitted with the ACAV armour kit which protected the main machine gun and added shields for two additional gunners. The M113 served in Vietnam as one of the most effective and widely used armoured vehicles of that war, and remains in service today as a lighter and less expensive alternative to purpose built IFVs.

M113

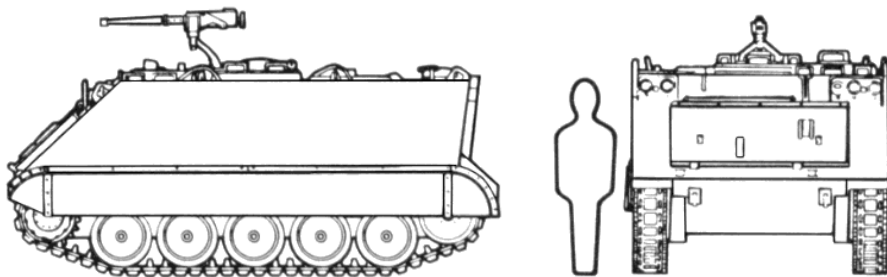
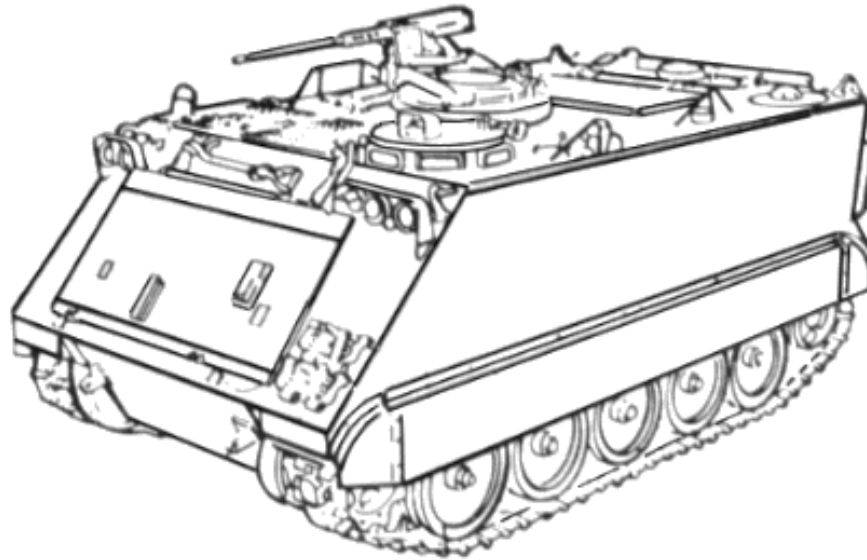

- M113 is an armoured personnel carrier family of vehicles
- Fully tracked vehicle
- Can handle limited amphibious operation in lakes and streams
- Extended cross-country travel over rough terrain
- High speed operation on improved roads
- Most widely used armoured fighting vehicles
- Designed as a transport to protect against artillery fragments
- Most widely used armoured vehicles of the Vietnam War
- It inspired newer generations of more heavily armoured and armed infantry fighting vehicles
- Main armament is a single .50-caliber (12.7 mm) M2 Browning machine gun operated by the commander
- M113 requires only two crewmen, a driver and a commander, and carries eleven passengers inside the vehicle

M113 (Specification)

General	
Length	191.5"
Width	105.75"
Height	86.5"
Clearance	16"
Weight, combat loaded	27,180 lb. (12,329 kg)
Maximum weight	31,000 lb. (14,061 kg)
Net weight	23,880 lb. (10,832 kg)
Air drop weight	22,128 lb. (10,037 kg)
Personnel capacity	2 + 11
Fuel tank capacity	95 gallons (360 litres)
Ground pressure	8.63 psi (0.60 kg/cm ²)
Performance	
Speed on land	41 mi/h (66 km/h)
Speed in water, with track	3.6 mi/h (5.8 km/h)
Cruising range	300 mi (483 km)
Turning radius	Pivot to infinite
Slope	60%
Side slope	40%
Trench crossing	66 in. (168 cm)
Vertical wall climbing	24 in. (61 cm)
Braking (20-0 mi/h)	40 ft.

Engine	
Make and model	Detroit Diesel 6V53T
Displacement	318 in.3 (5.2 litre)
Fuel	Diesel (DF2)
Rated horsepower	275 hp
Gross horsepower-to-weight ratio	20.2 hp/ton
Transmission, Automatic	
Make and model	Allison X200-4B
Type	Hydrokinetic
Steering	Hydrostatic
Brake type	Multiple wet plate
Running Gear	
Suspension	Torsion bar
Road wheels	5 per side, 24 inch diameter (61 cm)
Track type	Steel single pin, detachable rubber pad
Number of shoes	63 left, 64 right
Track pitch	6 in. (15.2 cm)
Track width	15 in. (38 cm)
Shock absorbers	3 per side
Wheel travel	9.0 in. (22.9 cm)

Electrical System	
Generator	
Amperes	200, 300 optional
Volts, dc	28
Batteries	4, type 6TL, 120 amp-hr, 12-volt each
Armament	
50 cal MG	2,000 ready rds.
Armour	
Basic hull	5083 Aluminium
Bolt-on armor kit	Steel armour
Mine armour	Steel armour
Gun shield kit	Steel armor
Spall suppressant	Composite panel
Fire Extinguishers	
Fixed	5 lb. (2.3 kg) CO2 for engine compartment
Portable	5 lb. (2.3 kg) CO2

2.2 INFANTRY COMBAT VEHICLE

((Changing Face With Time))



2.2.1 BMP-1



Western powers were surprised when the Soviet Union paraded the first purpose-designed IFV, the BMP-1, in 1967. The BMP possessed a very low profile and was armed with both a 73mm smoothbore gun and an AT-3 Sagger ATGM. Its steeply-sloped front armour offered partial protection against NATO's standard .50 calibre machine gun in a 60 degree frontal arc, while its smoothbore gun and ATGM were a threat to NATO APCs and even MBTs. It was not quite the breakthrough some would make it out to be, as in practice its performance was similar to the heavily-armed APCs which NATO countries had already begun to develop.

2.2.2 World Scenario : ICVs



German Marder-I



German Marder-II



German Puma



Canadian LAV III



British Warrior



American M2 Bradley



M1126 Stryker



Spanish Pizarro



Italian Dardo



Indian Abhay



South African Ratel



Swedish Combat Vehicle 90



French AMX-10P



Dutch YPR-765 AIFV

2.2.3 INFANTARY COMBAT VEHICLE

Where India stands????

On one hand India is there with age old fleet of BMP-2 & recently developed Abhay and ready to accept a bit advanced BMP-3, on the other hand, other superpowers in the world are standing with their advanced and high tech ICVs.

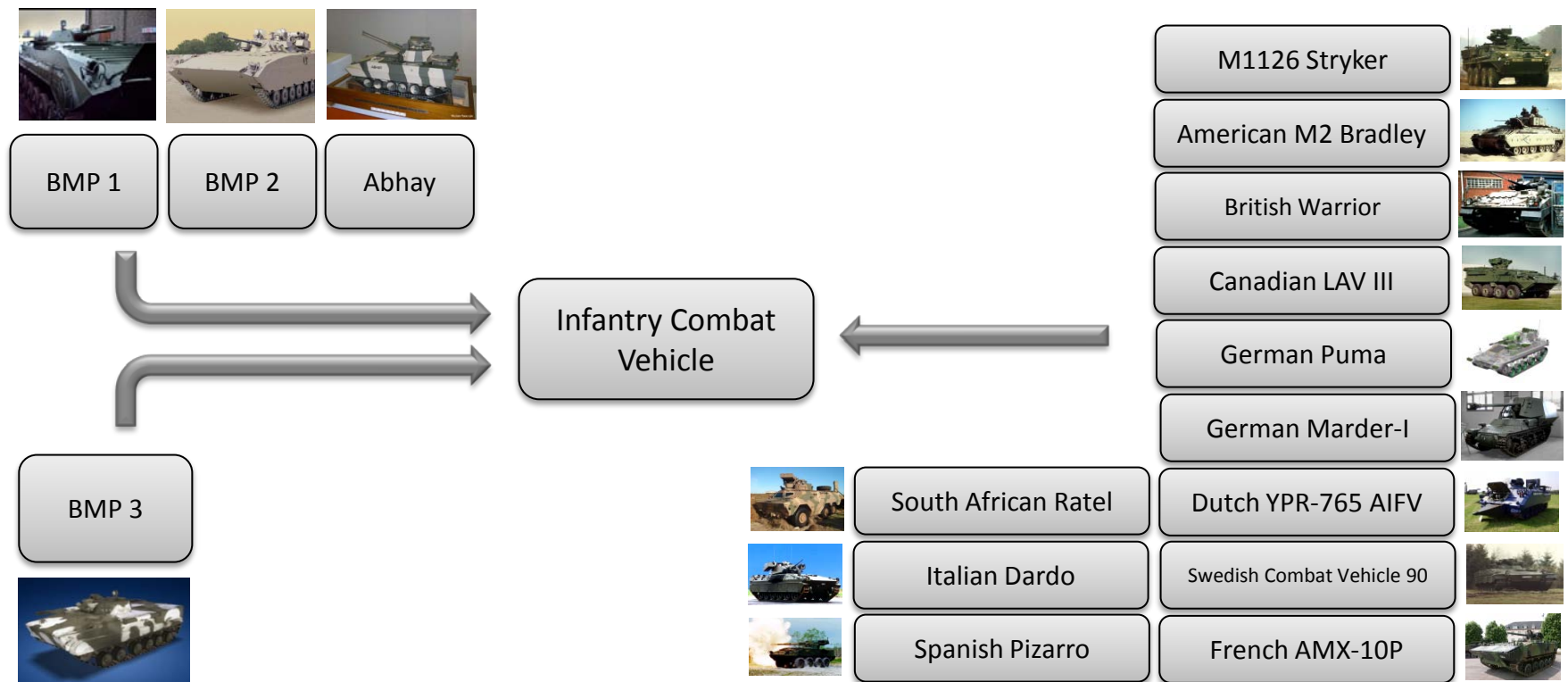

2.3 Various Aspects Of ICVs

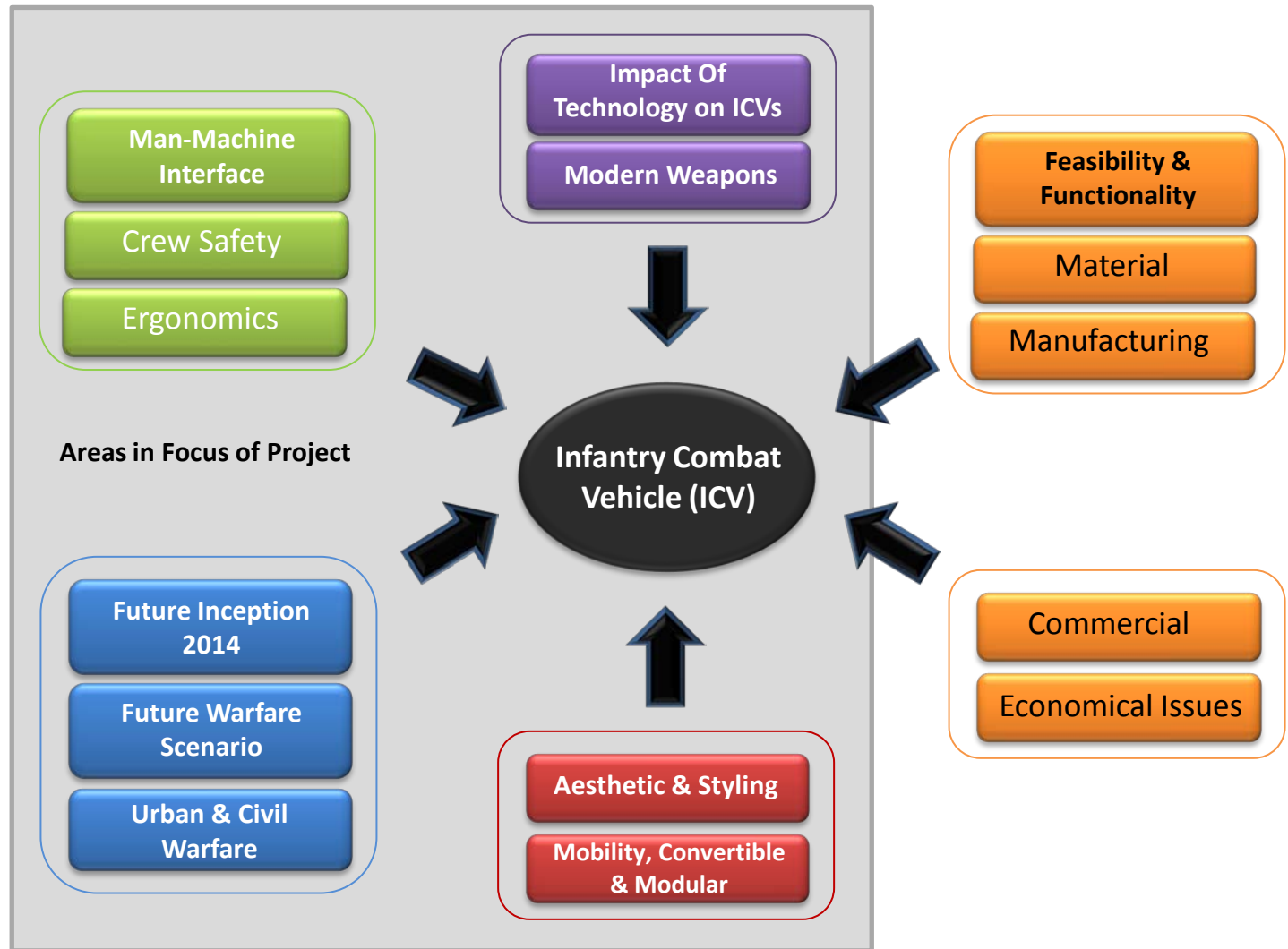

2.4 Introduction Of ICVs used in Indian Military

BMP2

- It is a further development of the 1960s BMP-1.
- The BMP proved vulnerable to .50 calibre machine gun fire in the sides and rear.
- Seven troops are carried instead of eight..
- Slightly improved armor.
- The commander sits with the gunner in an enlarged turret.
- BMP-1 has a capability to make its own smoke screen by injecting vaporized diesel fuel.



2.5 Current Generation ICVs

2.5.1 Technology Matrix

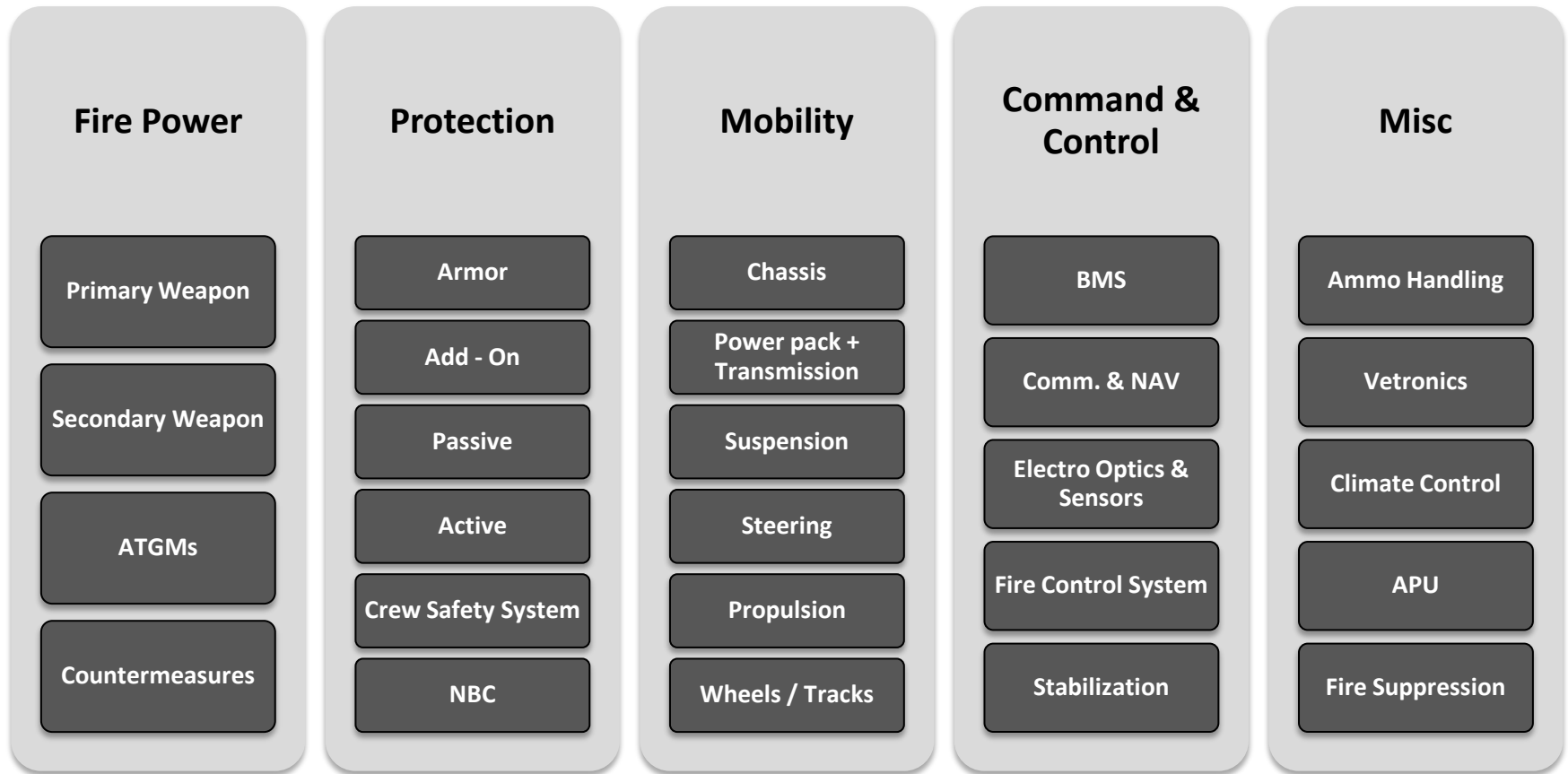

2.5.2 Current Generation ICVs & Their Specialties :

Puma Germany



- Heavily Armoured
- Highest Power-to-Weight ratio
- Combat weight 31.5 tons

VBCI France



- Best Armor to weight Ratio(claimed)
- Modular Armor

Stryker USA



- Light-weight(<20 tons)
- Armed with 12.7 cal gun

CV90 Sweden



- Armed with 40mm L70 cannon

Patria AMV Finland



- High export success
- Modular Construction
- Modular Armor
- Amphibious

BTR-90 Russia



- 0 turning radius possible
- Side-opening Doors
- Amphibious

Piranha Switzerland



- Most produced modern ICV series
- Amphibious

Dardo Italy



- Aluminum alloy armor

Bionix II Singapore



- Compact dimensions
- Amphibious
- Variant with Grenade Launcher

BMP-3 Russia



- Most heavily armed ICV
- Lightly armored
- Amphibious

ASCOD Spain / Austria



- Co-operation between Spain & Austria
- Next version to be armed with BMP-3 turret

2.5.3 ICVs at Glance

Sr.	Program	Country	Mobility	Crew	Weight	Power to Weight Ratio	Armament Calibre (mm)	
							Primary	Secondary
1	Puma	Germany	T	3+6	31000	34.09	30	5.56
2	VBCI	France	W	2+9	26000	20.81	25	7.62
3	Stryker	USA	W	3+8	19000	21.88	12.7	7.62
4	CV90	Sweden	T	3+7	25000	23.69	40	7.62
5	AMV-Hitfist(Patria)	Finland	W	3+8	24000	22.65	30	7.62
6	BTR-90	Russia	W	3+7	20920	23.62	30	7.62
7	Piranaha IV	EU	W	2+8	25000	21.48	30	7.62
8	Dardo	Italy	T	3+8	23000	22.28	25	2 x 7.62
9	Bionix 2	Singapore	T	2+9	21500	22.16	30	7.62
10	BMP-3(upgraded)	Russia	T	3+7	18900	34.31	100	30+3x7.62
11	Ascod/Pizzaro/Ulan	Spain	T	3+8	25200	23.49	30	7.62

Observations :

- Average power to weight ratio ~ 20 hp/ton
- Average weight > 20 tons
- Primary armament ~ 30 mm cannon
- Secondary armament ~ 7.62 mm MG
- Mobility : Mix of Track & Wheel

2.5.4 ICV Armament

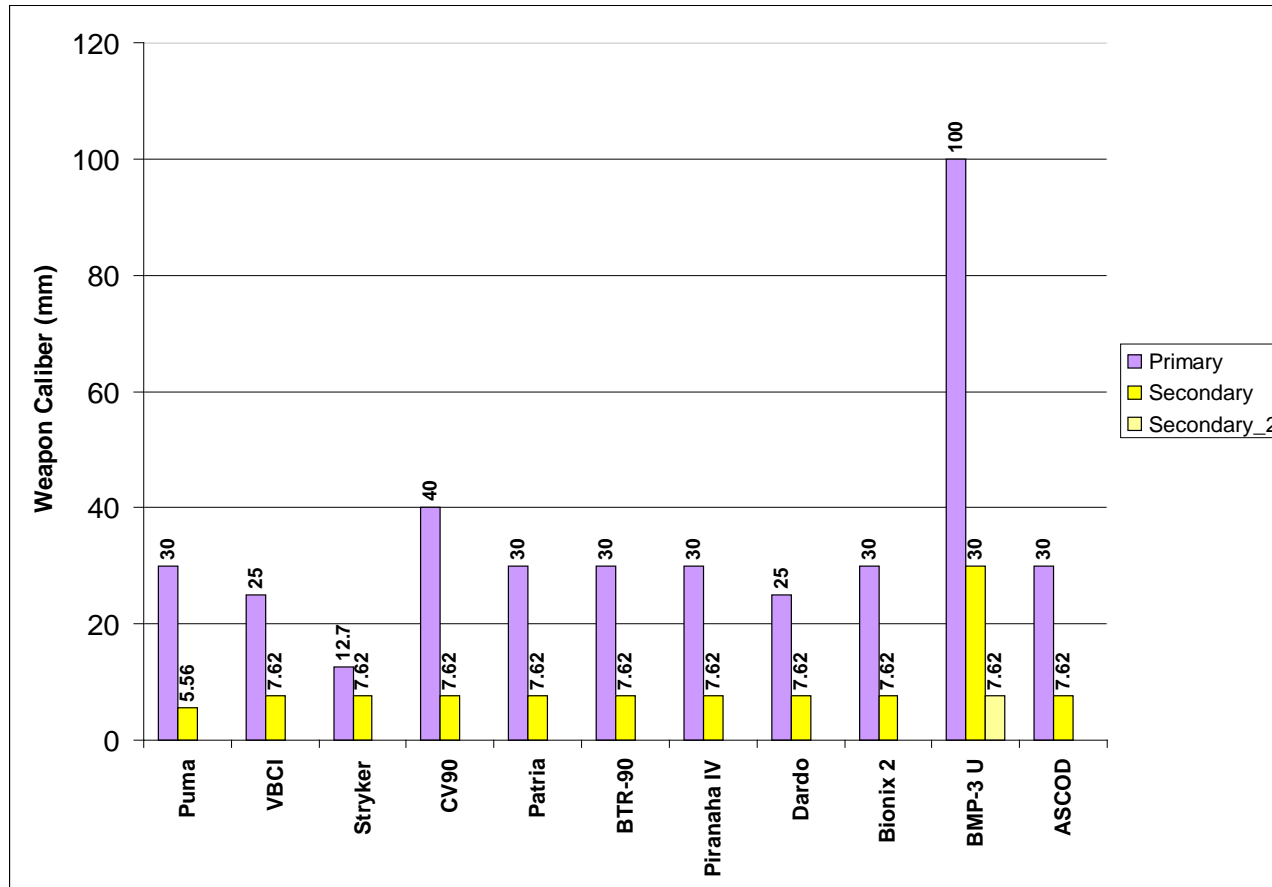







Observations:







- Std. Primary armament is 25~30mm
- Std. Secondary armament is 7.62mm
- BMP-3 has a 100mm cannon as well as a 30mm

2.5.5 ICV Protection

Sr.	Program	Std. Armor protection (against cal.mm)	Upg. Armor protection (against cal.mm)	weight std. (tons)	weight Up - Armored. (tons)
1	Puma	30 (Frontal + Arc + flank) +14.5 (all-round)	30+(all-round)	31.5	41.3
2	VBCI	30(Frontal) est. 14.5(all-round)	N/A	26	N/A
3	Stryker	14.5 (all-round)	add on reactive armor	19	23
4	CV90	14.5 (all-round)	30(Frontal-Arc) +30(sides)	24	28
5	AMV-Patria	14.5+(allround)est.	30mm	16	26
6	BTR-90	12.7 (all-round)	N/A	21	N/A
7	Piranaha IV	14.5 (all-round)	add on reactive armor	N/A	25
8	Dardo	N/A	Steel plates	23	N/A
9	Bionix 2	N/A	N/A	23	N/A
10	BMP-3 U	30(frontal) +7.62(all-round)	12.7(all-round)+ERA	18.9	22.9
11	ASCOD	14.5(Frontal) +7.62(all-round)	30(Frontal-Arc) +14.5(all-round)	25.2	28.5

2.5.6 BMP-2 Armor Protection (Existing)

Thickness of Armor	
	16mm
	15mm
	12mm
	6mm
	5mm
	4mm

Thickness of Armor	
	16mm
	15mm
	12mm
	6mm
	5mm
	4mm

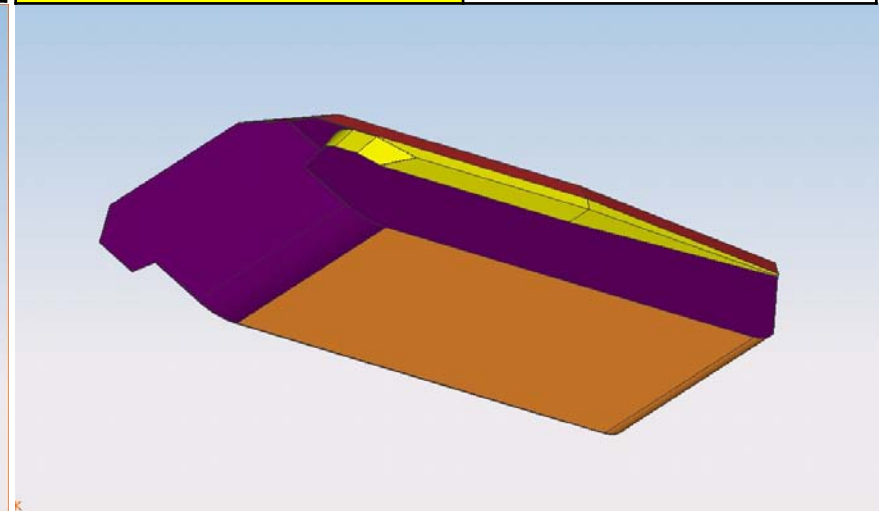
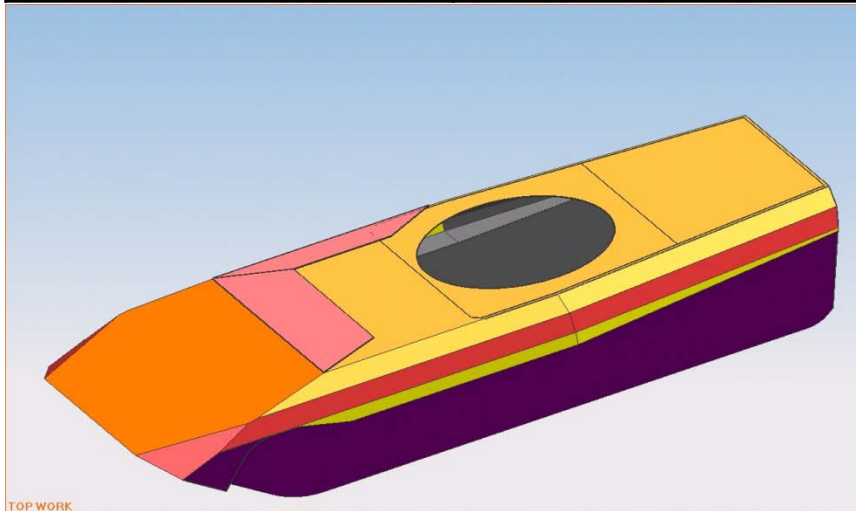

2.5.7 ICV Performance - Power v/s Weight

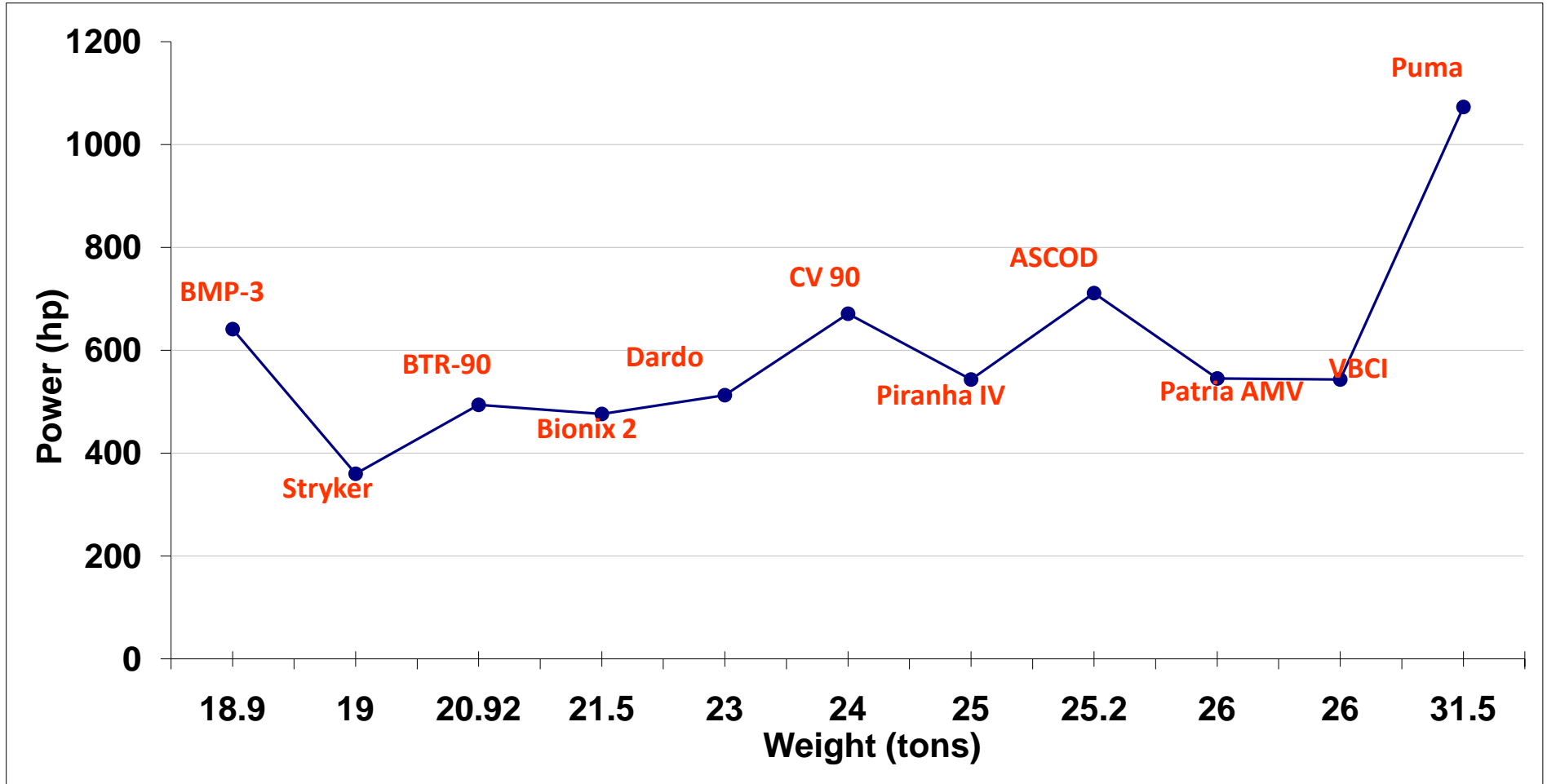

power v/s weight

2.5.8 ICV Performance - hp/ton

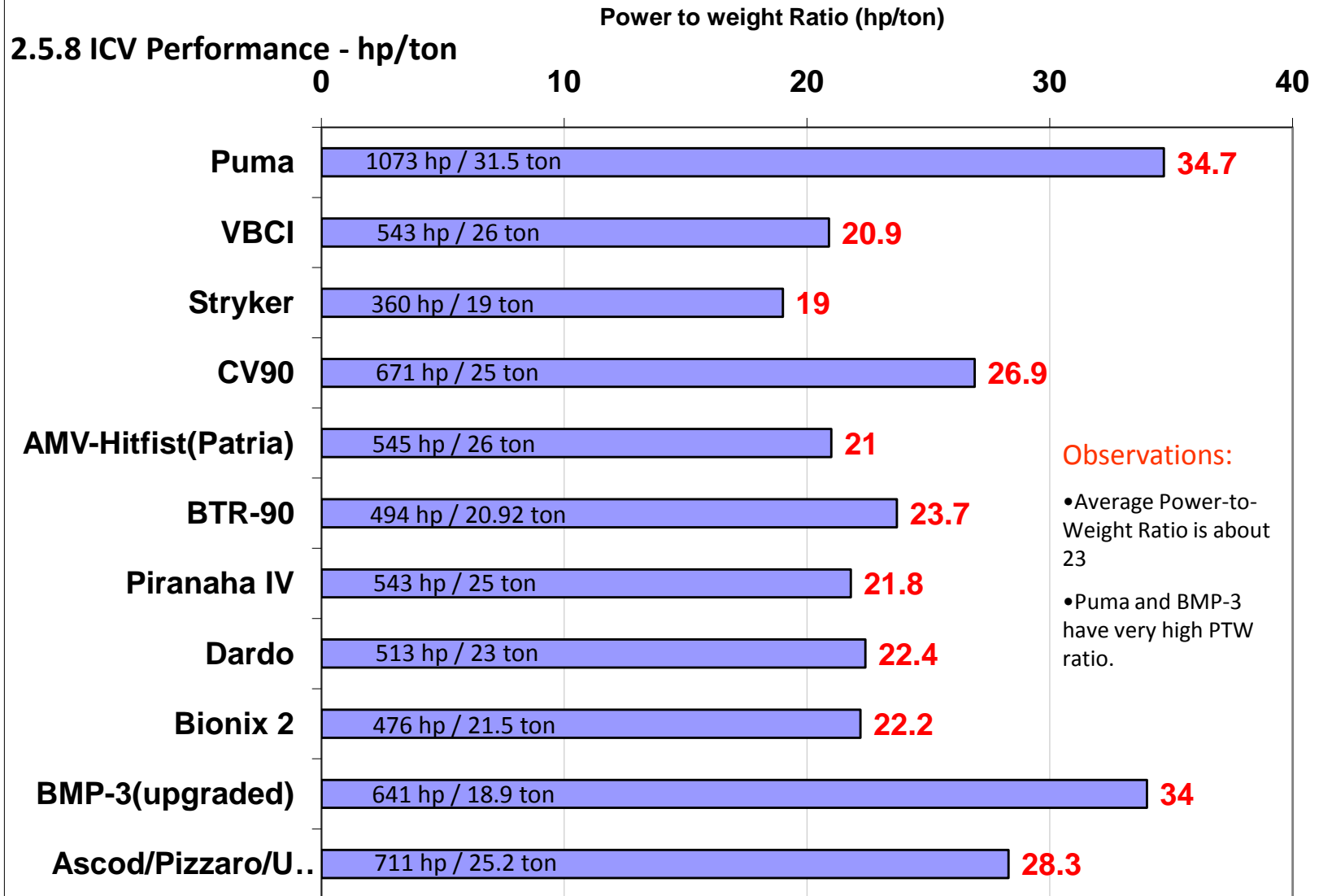

2.5.9 ICV Performance - Range

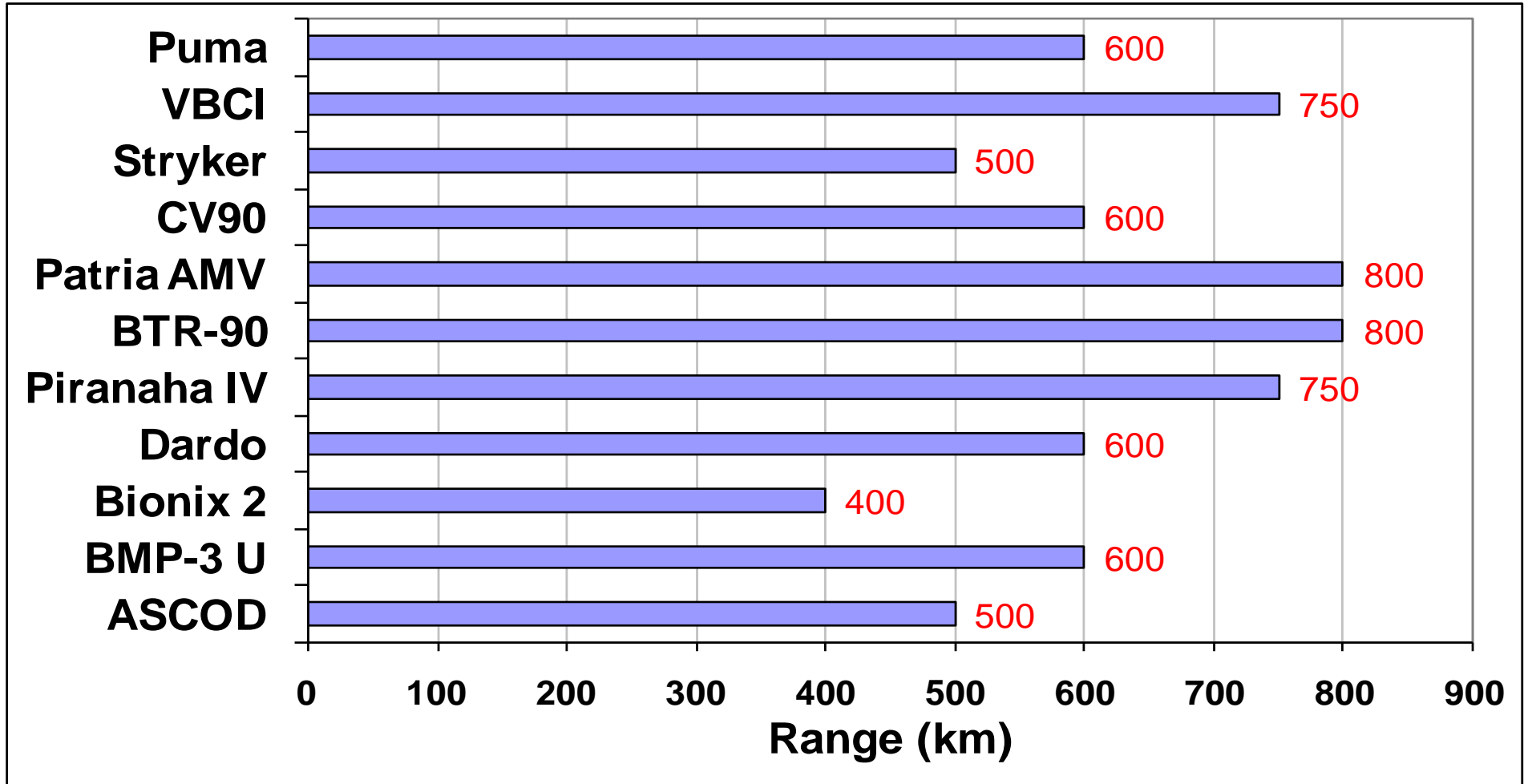

2.6 Types of ICV

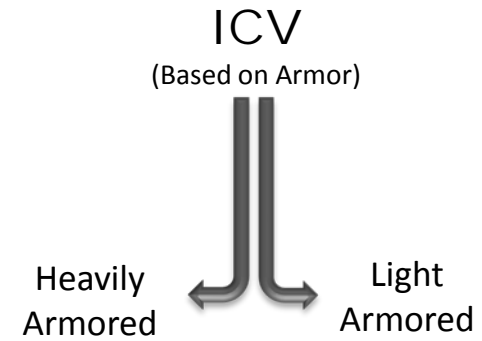
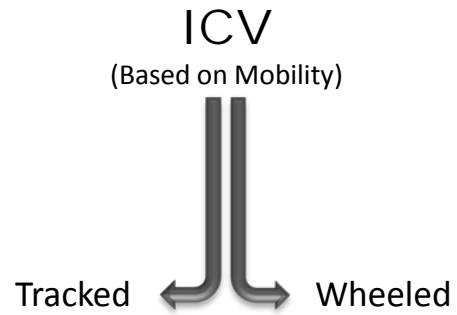

2.6.1 Wheel v/s Track- A Comparison

Sr. No.	Criteria	Tracked	Wheeled
1	Cross-Country Mobility	✓	
2	Traction on Slopes	✓	
3	Road Speed	70 km/h top speed	100 km/h top speed ✓
4	Operating and Service Costs		✓
5	High GVW, Volume and Payload	✓	
6	Gap and Obstacle Crossing	✓	
7	Fuel Economy		✓
8	Reliability		✓
9	Low Silhouette	✓	
10	Maneuverability / Turning Radius	✓	

2.7 New Technologies in ICVs

01) Hybrid drive (Sweden)

Engine charges the battery that helps to drive motor, which is one of the source of mobility. Greater usable internal volume.

Improved stealth characteristics

- **Thermal Signature** is reduced as the engine can be shut down if needed
- **Acoustic Signature** is also reduced as the engine can be shut down and motor can be used instead



02) Active Suspension

New Active Suspension Systems are available which can Auto adjust to terrain conditions.

03) Modular Construction

- Allows easy upgradability.
- Conversion according to mission profile.
- Ease of maintenance.

Modular Construction



04) Modular Armor

- Can be replaced easily.
- Protection can be varied according to mission.

Modular Armor



05) Continuous rubber band tracks

- Much quieter and lighter than conventional steel tracks

06) Electric Reactive Armor (Lockheed Martin)

- Armor is made up of two or more conductive plates separated by some space or by an insulating material, creating a high-power capacitor.
- In operation, a high-voltage power source charges the armor. When an incoming body penetrates the plates, it closes the circuit to discharge the capacitor, dumping a great deal of energy into the penetrator.

07) 40mm Case Telescoped Weapon System (BAE+Nexter)

- Round size is similar to 30mm while being much more lethal.
- Compact and lightweight.



08) Air Burst Munition (ABM)

- Round size is 30mm and higher.
- Very effective against infantry and soft targets.
- Electronic timed fuse.
- Can be used to attack “behind the wall” targets.
- Can disable sensor systems of enemy armored units.
- Expensive.

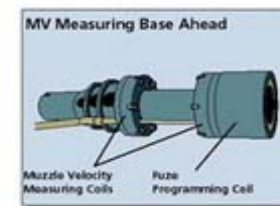
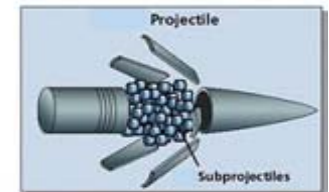
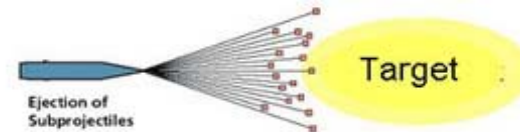
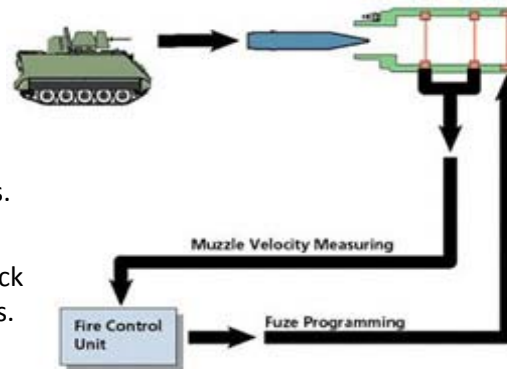

2.8 Deficiencies in ICVs

2.8.1 Deficiencies in Current ICVs

- Infantry men are not effectively able to fire from the vehicle on the move.
- Roof is lightly armored, hence vulnerable against top attack weapons.
- Simultaneous Multiple Target Engagement not possible.
- US experience of wars in 1991 and 2003 showed lack of proper IFF –(Identification Friend or Foe) Systems.
- ICVs using Steel Armor are inherently heavy.
- Most ICVs vulnerable to mines and RPGs.

2.8.2 Deficiencies in BMP-2

1) Troop seating

Soldiers sit on two back-to-back benches, mounted along the centreline of the fighting compartment.

In case of Mine explosion under hull, even Fuel Tank bursts, could kill the entire crew.

2) Fuel tanks placement

Due to low profile of BMP-2 fuel tanks have been placed between the two rows of outward-facing passenger seats, thus the infantry passengers actually sit on the bulk of the vehicle fuel storage.

3) Door Fuel Tank

Door itself also is used for the storage of the fuel, which can be a major source of explosion in the battle scenario. So, it has to be taken into consideration.



Seats



Fuel tank

04) Lightly Armoured

Against 12.7mm cal.(old gen.) In frontal arc and 7.62mm cal. all round . No protection against mines.

05) Reloading cannon problematic

Takes up to two hours to reload.

06) Paint

The Paint that they use for painting comes for Rs.60 per Ltr. One of the cheapest & worst type of protection, which doesn't even the basic Camouflaging .

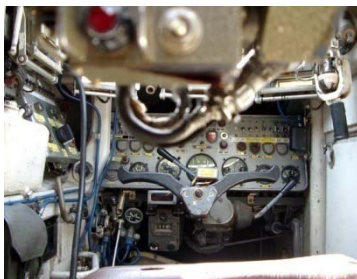

07) Poor control Panels

are there for the Driver and Commander and lack the modern technology. For quite a long time it has not changed and basically contains Analog Controls.

08) Firing Holes

As the bullets and artillery fragments do use to come through the firing ports, injuring infantrymen.

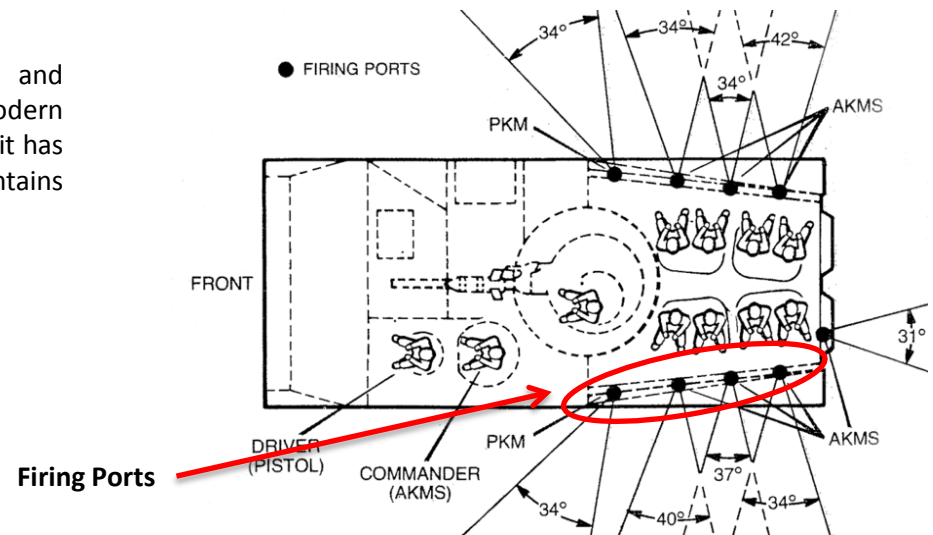

09) Instructions

All the instructions written inside the BMP-2 Vehicle are in Russian Language. So, this type of problems can lead to confusion.

10) Cabin Ambience

The lighting inside the crew cabin is Blue, poor visibility.

11) Emergency Exits

Extra Exits are needed at the time of Emergency for Escaping.

12) Harness

There is no provision for seat belts (Harness) in BMP-2. So, it really becomes difficult to sit as well as handle Machine Guns by the soldiers while the Vehicle is on move.

13) Heating of the Crew Compartment

Heating of the BMP-2 Crew Compartment in Indian Climatic scenario is also of big concern. In case of Rajasthan like areas, due to Engine and out side heat. crew compartment temperature rises up to 58 Degree C.

14) No cushioning

on the Seats although Vehicle undergoes severe jerks .

15) Grenade Launchers

The Grenade Launchers on the vehicles are fixed either on turret. So each time you have to fire grenade launcher, vehicle or turret has to be moved.



No Harness & Cushioning on the Seats



Grenade Launcher on Turret

16) Crew Seat

The seats used in the BMP-2 has side profile as shown in figure. At the edge, seat corner is sharpe, that makes the seating sitting uncofortable.

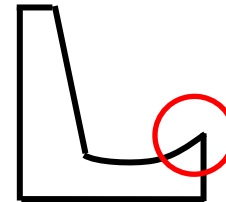

Crew Seat



Crew Seat

17) Crew Sitting Height :

Crew sitting Height in case of BMP-2 is 20cm which is h Pathetic, worsen the sitting..

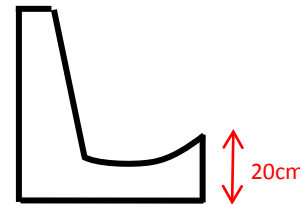

Crew Seat

Grenade Launcher on Turret

2.8.3 Good feature of BMP-2

In comparison to the other ICVs which has side exhausts, BMP-2 has upper Exhaust Vents. This is a good feature. During battle, bullets & artillery fragments penetrates the side vents that leads to explosion.



Upper Exhausts

2.9 Camouflaging



2.9.1 Camouflaging : Mapping

It is one of the most important level of protection against enemy. Modern ICVs are all laced with all the new camouflaging. There are various types of factors against which the camouflaging is deployed.

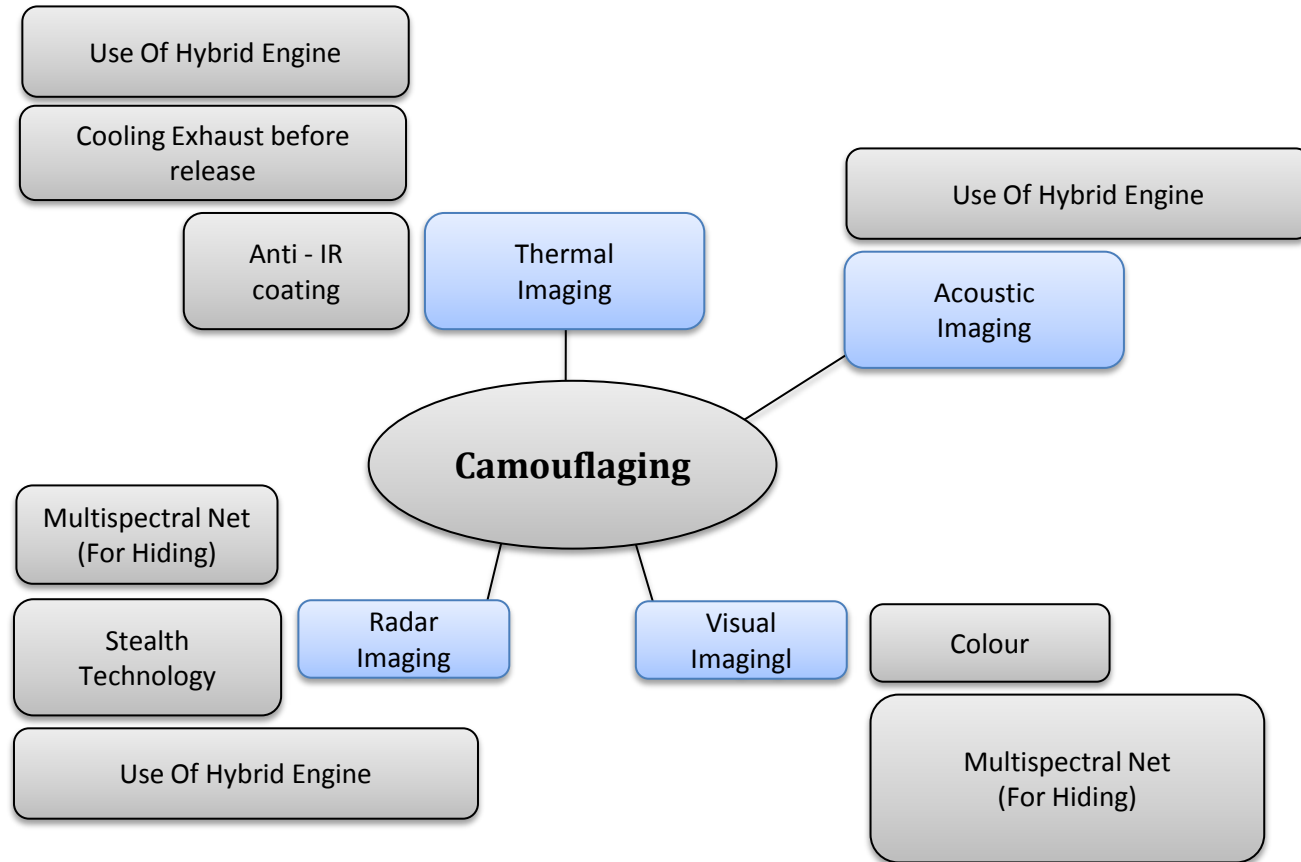

2.9.2 Radar Signature

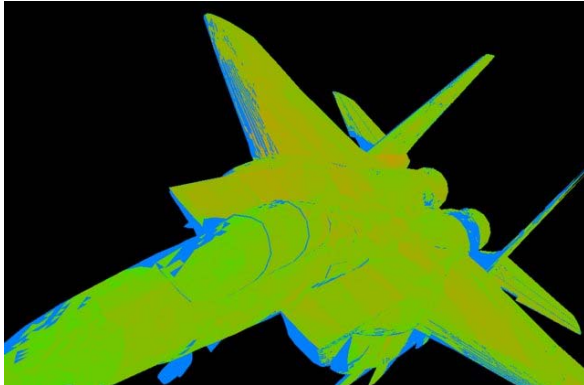

Radar Signature is The detailed waveform of a detected radar echo. Radar cross section (RCS) is a measure of how detectable an object is with a radar. When radar waves are beamed at a target, only a certain amount is reflected back. A number of different factors determine how much electromagnetic energy returns to the source, such as the angles created by surface plane intersections. For example, a stealth aircraft (which is designed to be undetectable) will have design features that give it a low RCS, as opposed to a passenger airliner that will have a high RCS. Similar is the case of new age ICVs to protect it from its Predators.

- Radar Signature of an object depends on the amount of radio energy sent by the radar it deflects back to the radar
- Certain cross-sections & wedge like shapes reflect very low amount of radio energy back to the radar
- Reflections cant be completely removed
- Surface treatment to absorb radar energy
- Combined result : ICVs can have a signature as small as a small animals
- Stealth Technology can be used to eliminate the RADAR signature.

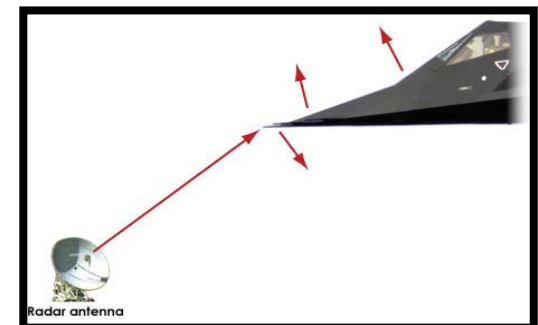
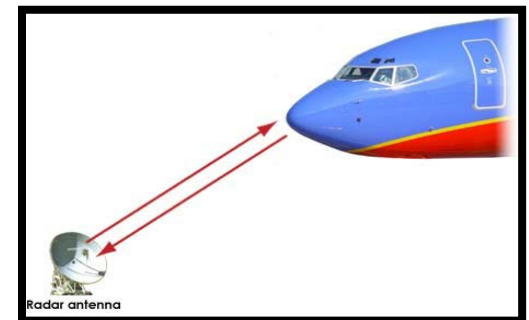

2.9.3 Thermal Signature

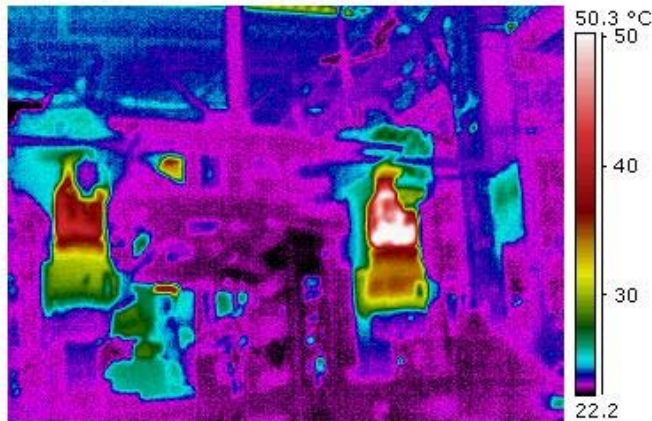

Infrared Thermography, thermal imaging, thermographic imaging, or thermal video, is a type of infrared imaging science. Thermographic cameras detect radiation in the infrared range of the electromagnetic spectrum (roughly 900–14,000 nanometers or 0.9–14 μm) and produce images of that radiation. Since infrared radiation is emitted by all objects based on their temperatures, according to the black body radiation law, thermography makes it possible to "see" one's environment with or without visible illumination. The amount of radiation emitted by an object increases with temperature, therefore thermography allows one to see variations in temperature (hence the name). When viewed by thermographic camera, warm objects stand out well against cooler backgrounds; humans and other warm-blooded animals become easily visible against the environment, day or night. As a result, thermography's extensive use can historically be ascribed to the military and security services.

- Heat energy emitted is a potential source for ICVs being the target of Fighter Crafts using Infrared & heat seeking missiles
- Surface coatings are available that reduce thermal signature and camouflage against surroundings.
- Match thermal signature with that of the environment is one of the remedy.
- Running the ICVs on battery power during war (Hybrid Drives).

Figure:

1 – ICV without Anti-Thermal Coating

2 – ICV with Anti-Thermal Coating



2.9.4 Acoustic Signature

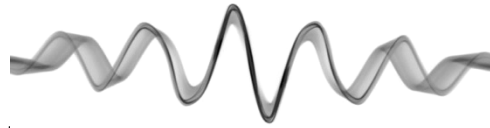

Sound from ICVs can also be lethal for them and can destroy other camouflaging protections.

Many fighter planes deploy, the acoustic imaging system, consists of three major components the ultrasonic sensor, sensor controller, and personal computer. The ultrasonic captures the sound wave input while the personal computer displays the image output on a computer screen. The personal computer use MATLAB to process the signals provided by the ultrasonic sensor. It enables to image any vehicle running on the ground.

So, dampening of the Acoustic source is also of great concern.

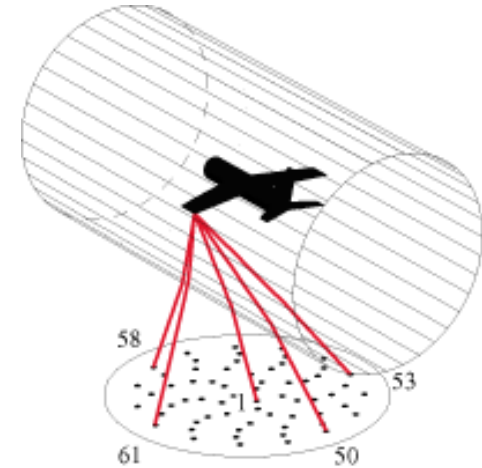

2.9.5 Visual Signature

External Body Painting of ICVs is also of much importance and is the primary level of protection. Choose of good quality color paint keeping in mind the Climate & Terrains , in which the ICVs are to be used can provide a better and economical Protection level.



3 Project Brief

After understanding the insights from the data collection concerning the history of ICVs and the current Indian and International scenario it is clear that what user desires to see is an ICV in terms of usability, simplicity of operation, comfort and performance. Concerning the above issues the following brief is written for the project:

“The goal of the project is to achieve a perfect balance between the bookends of appearance, function and safety of the crew members as well as the vehicle and targets to develop an ICV to enhance its service to the user in terms of functionality and user convenience with regards to war-fare ergonomics.”

4 Ergonomic Analysis & Layout

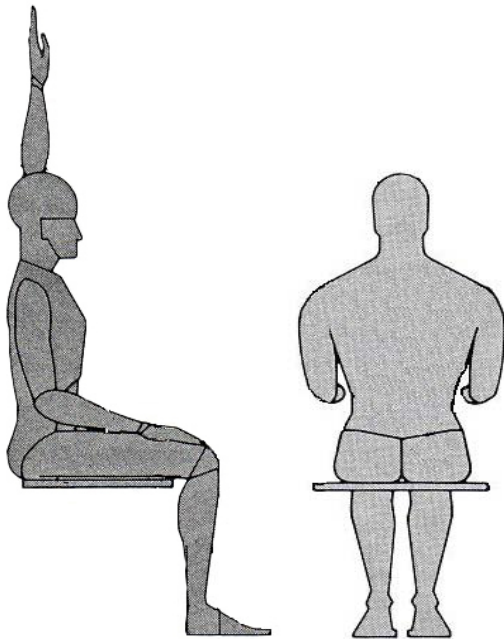

4.1 Ergonomic Analysis :

Ergonomic Analysis of ICV was done to get better crew sitting arrangement and wise utilization of the available space. Here calculation is done for the 95th percentile, later the dimensions have been optimized according to Infantrymen of all heights wherever needed.

Here shown is the crew sitting arrangement of the BMP-1 as reference to start. In case of BMP-2 which is our focus of design change, the turret was made bigger and commander has to sit in that with Gunner.

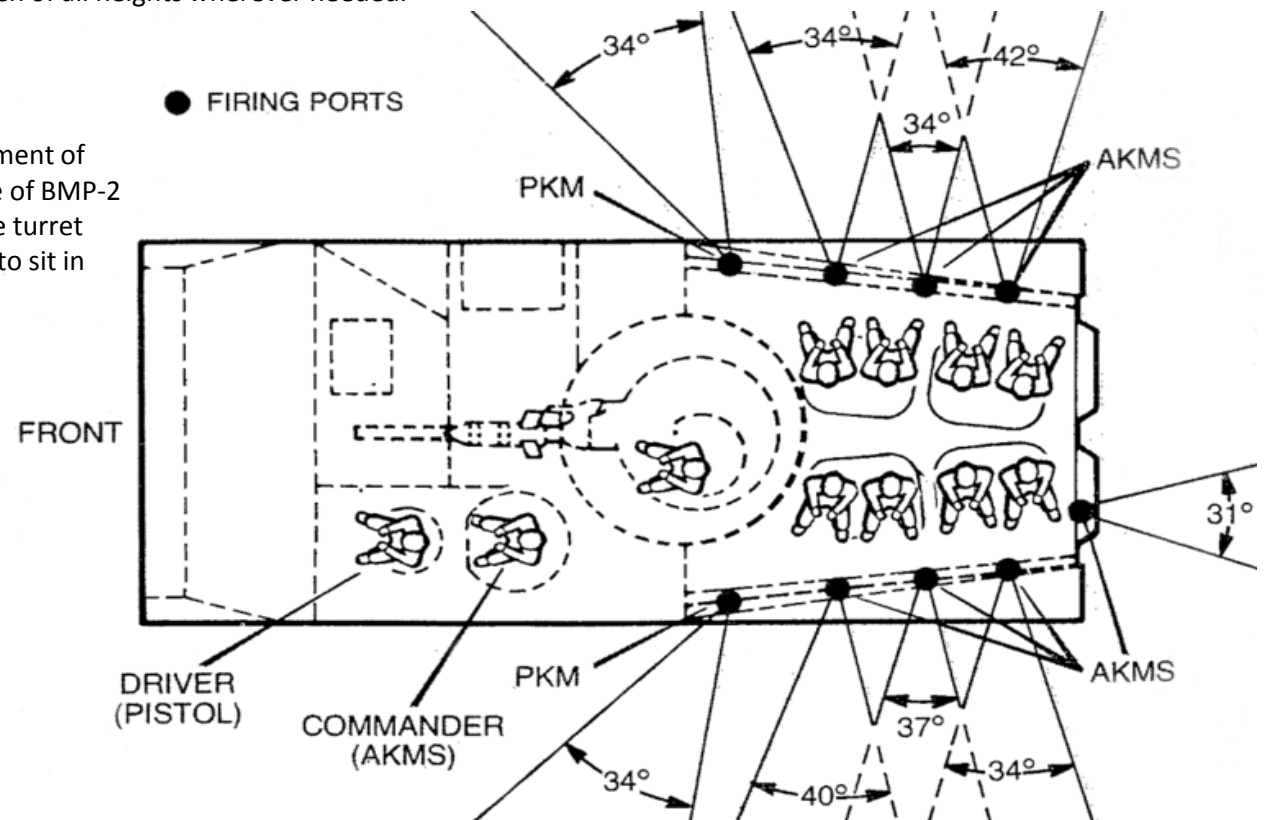

4.2 Abbreviations used throughout the Ergonomic Analysis

A1	Sitting Height (Erect)
A2	Sitting Height (Normal)
B	Elbow-to-Elbow Breadth
C	Hip Breadth
D	Elbow Rest Height
E	Thigh Clearance
F	Knee Height
G	Popliteal Height
H	Buttock Popliteal Length

I	Buttock Knee Length
J	Shoulder Breadth
K	Mid-Shoulder Height Sitting
L	Buttock-Toe Length
M	Thumb Tip Reach
N	Side Arm Reach
O	Vertical Reach Height Sitting
P	Maximum Body Depth
Q	Eye Height Fitting

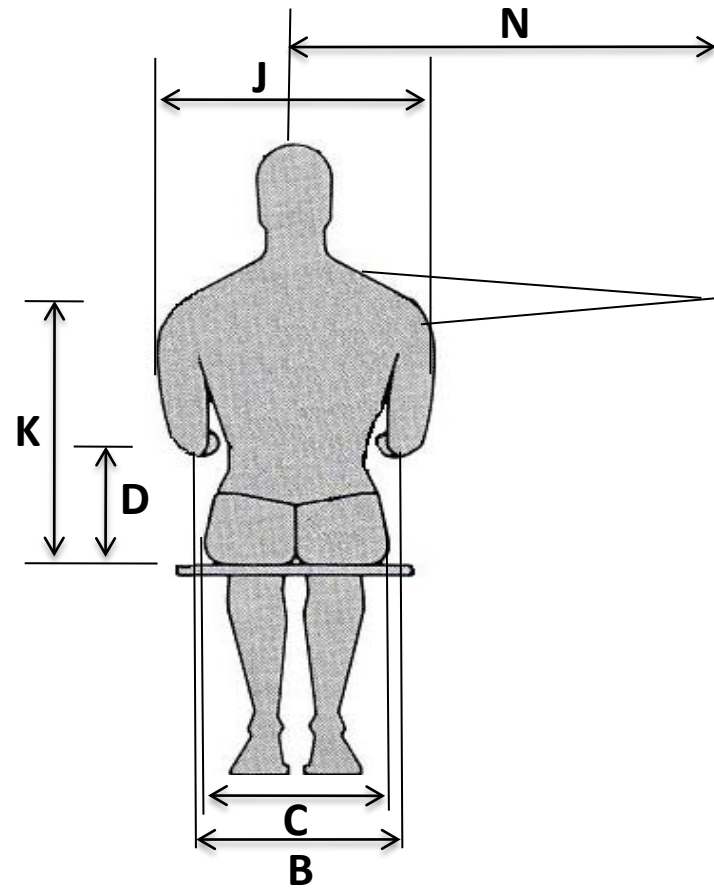
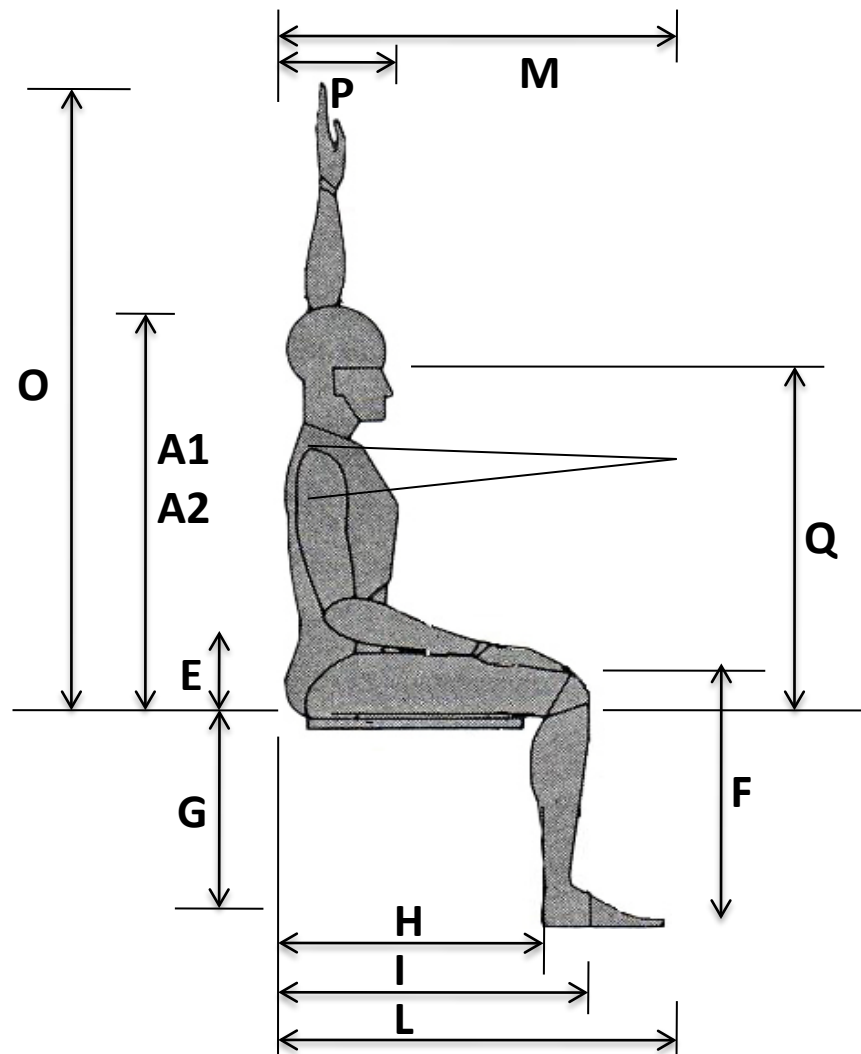

4.3 Ergonomic Data

01 Stature

Age		18 - 24	25 - 34	35 - 44
5th		163.3	163.6	163.1
50th		174.2	175.3	174.2
80th		180.1	181.4	179.6
95th		185.7	187.5	184.2

02

	J (Shoulder Breadth)	M (Thumb Tip Reach)
5th	44.2	82.3
95th	52.6	97.3

03 Vertical Reach Height Sitting

Age		18 - 24	25 - 34	35 - 44
5th		84.6 / 81.0	82.6 / 81.5	85.6 / 81.3
50th		91.2 / 86.9	91.7 / 87.4	91.4 / 87.1
80th		95.8 / 89.9	94.7 / 90.4	95.8 / 90.2
95th		97.3 / 93.2	97.5 / 93.5	96.5 / 93.2

04 Knee Height

Age		18 - 24	25 - 34	35 - 44
5th		49.3	50.3	49.3
50th		54.6	54.9	54.6
80th		57.2	57.7	57.2
95th		59.4	61.0	59.4

All the dimensions are in cm

05

		18 - 24	25 - 34	35 - 44
5 th	G	40.6	40.6	39.6
	B	33.3	34.8	35.8
	C	30.5	31.0	31.5
50 th	G	44.5	44.5	43.9
	B	39.1	41.4	42.4
	C	34.3	35.6	35.8
80 th	G	47.0	47.2	46.2
	B	43.7	45.2	46.5
	C	37.1	37.8	38.1
95 th	G	49.8	50.0	48.5
	B	49.3	50.0	50.8
	C	40.1	40.6	40.4

Calculations For 95th Percentile

	18 - 24	25 - 34	35 - 44	Avg.
A1	97.3	97.5	96.5	97.10
A2	93.2	93.5	93.2	93.30
B	49.3	50.0	50.8	50.03
G	49.8	50.0	48.5	49.43
J				52.60
L				94.00
M				88.90
N				86.40
O				131.10
P				33.00
H	54.9	55.6	55.4	55.3

All the dimensions are in cm

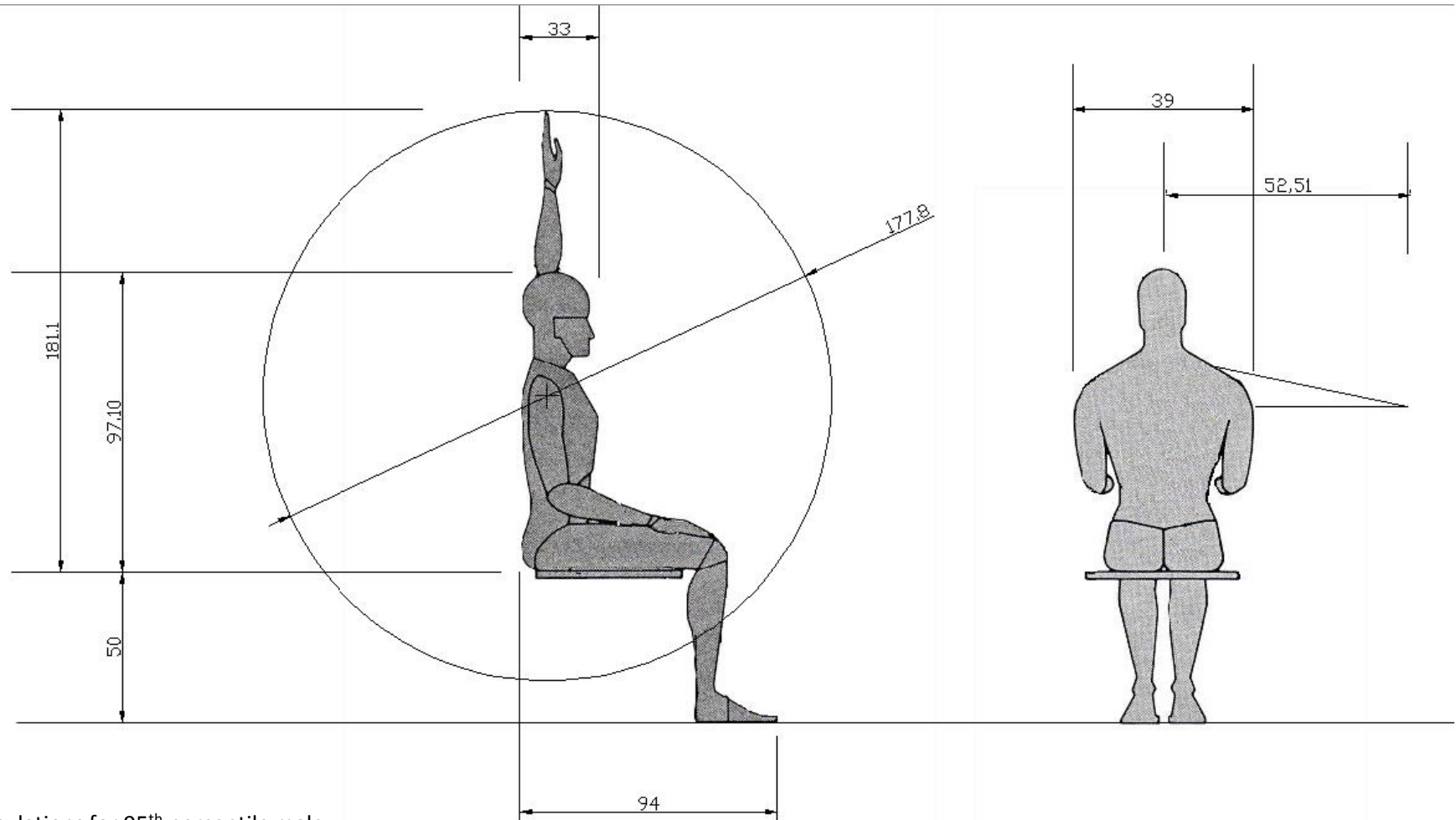

Calculations for 95th percentile male
 All the dimensions are in cm

4.4 Various Layout Plans

Layout 1

Designing of the layout started all with new approach of giving all the infantrymen to have Automatic Machine Guns so that they can fire through joysticks. The major advantage was that Infantrymen will be saved from the exposed firing ports in the conventional ICVs. The dimensions of this layout is given in the diagram. The dimensions used for the designing was directly taken from the ergonomic Analysis, there was no optimization. Here two seating arrangements have been shown for the Crew men. One back to back and another back facing the wall.

The biggest disadvantage was, plenty of space it was taking for the additional joysticks and LCD Panel. Later going through the technical details, it was found that the efficiency of the even 2 infantrymen firing through the joysticks is equivalent to all the Infantrymen firing in the conventional ICVs. So, for the better utilization of the space, layout had to be changed.

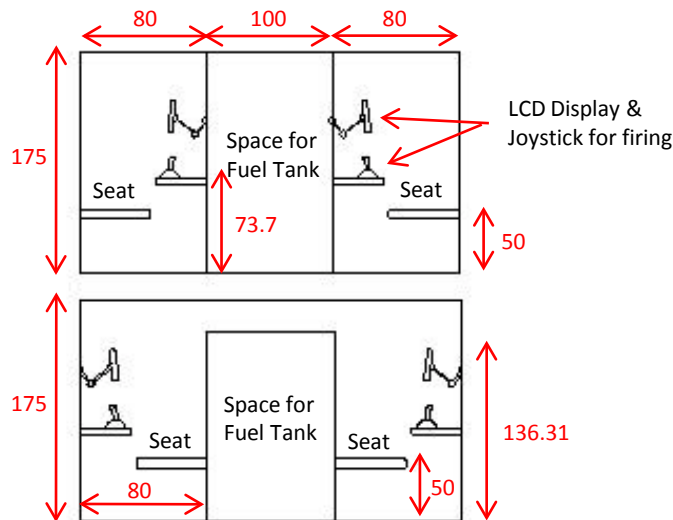

Calculations for 95th percentile male : All the dimensions are in cm

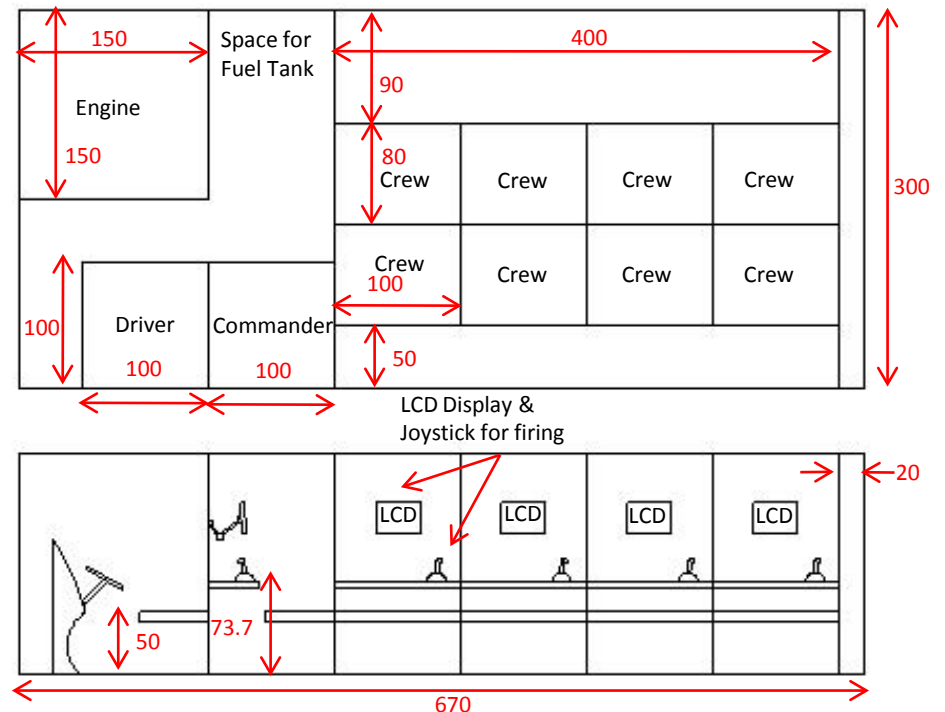

Layout 2

Stage2 comes up with the better utilization of the space , decrease in the vehicle length, Track & Layouts were also considered in the layout and a bit detailed dimensions of the major parts.

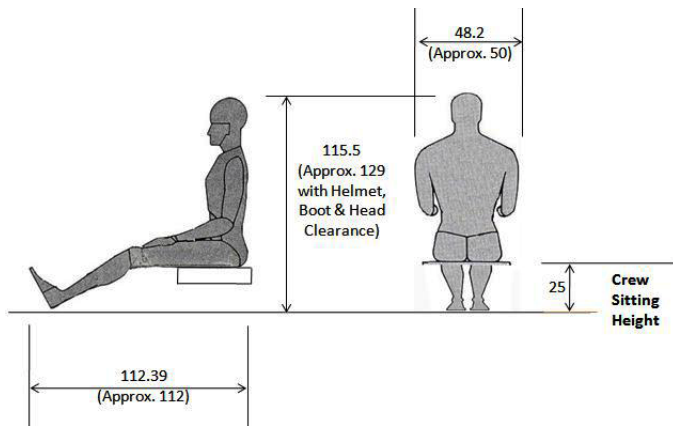

Back View

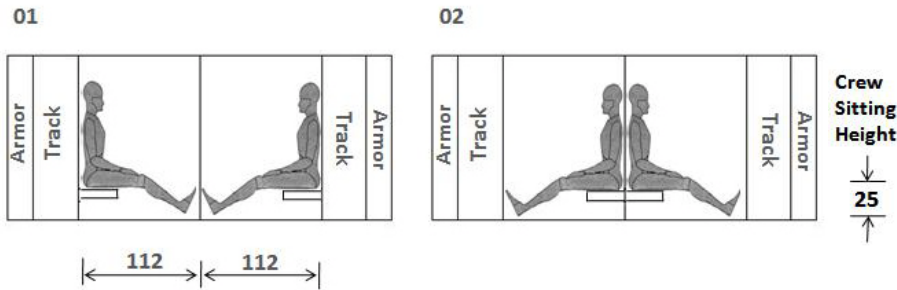

Calculations for 95th percentile male : All the dimensions are in cm

Top View

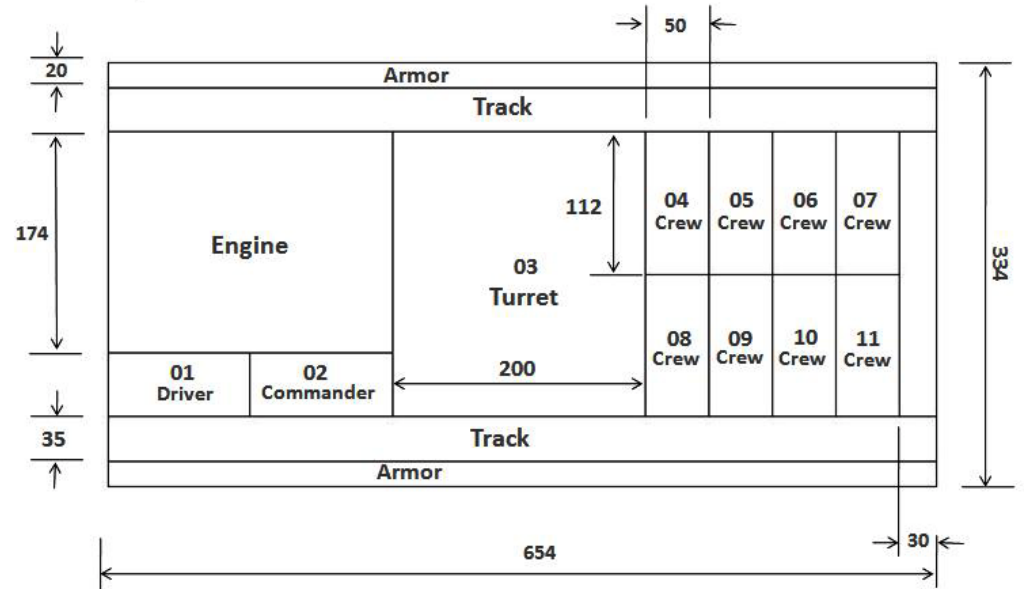

All the dimensions are in cm

Side View

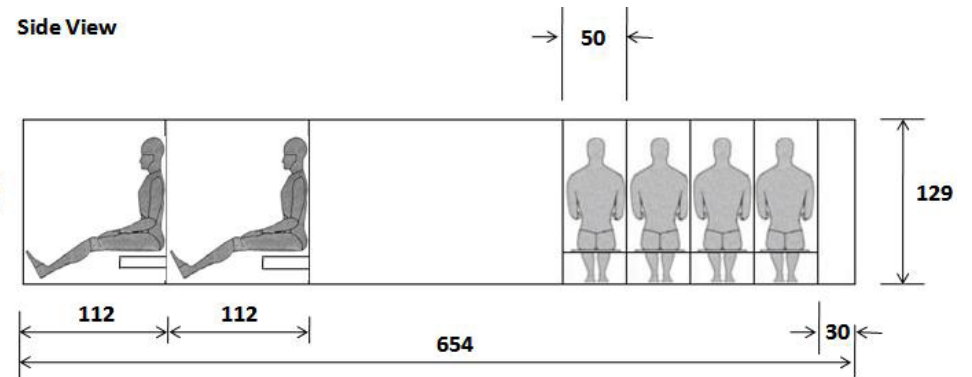

Layout 3

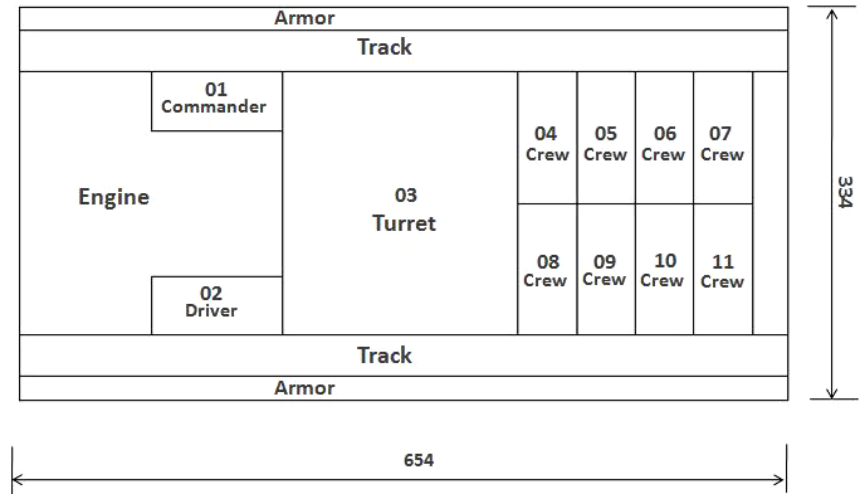
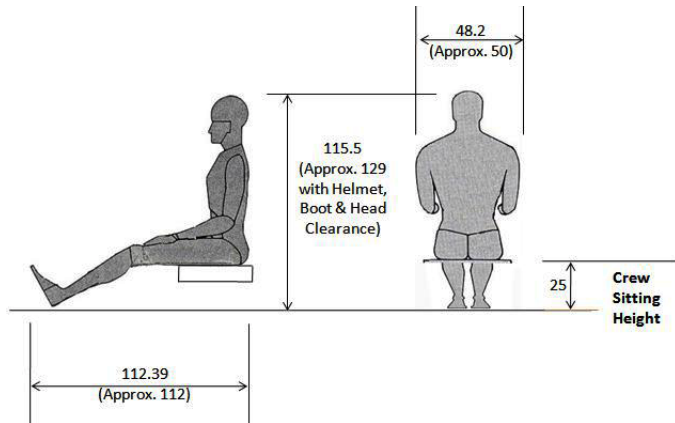

All the dimensions are in cm

Back View

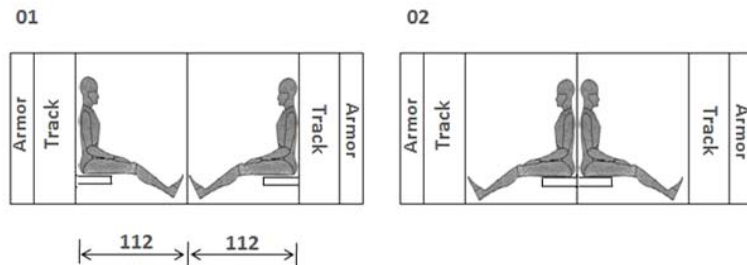

Side View

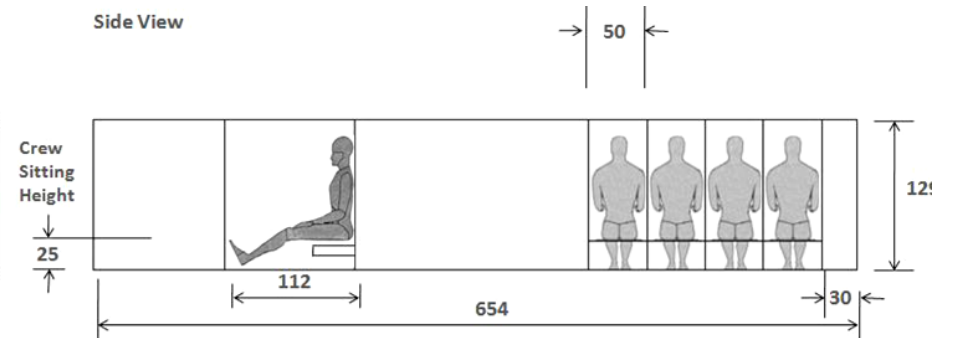

Calculations for 95th percentile male
All the dimensions are in cm

Layout 4

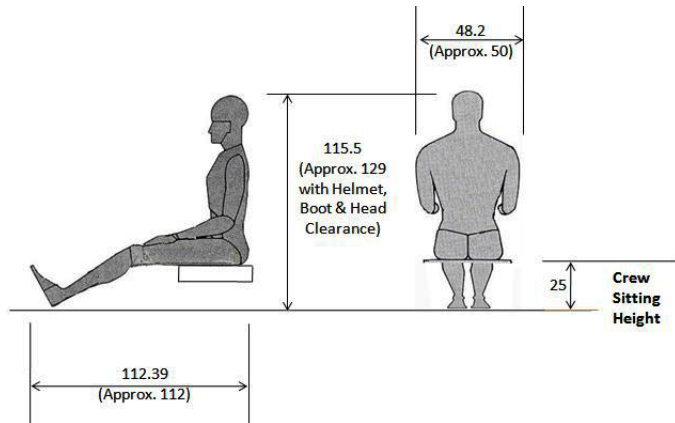

Back View

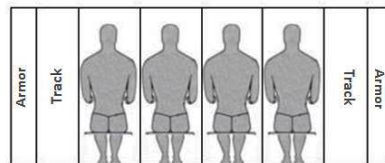

310

Calculations for 95th percentile male
All the dimensions are in cm

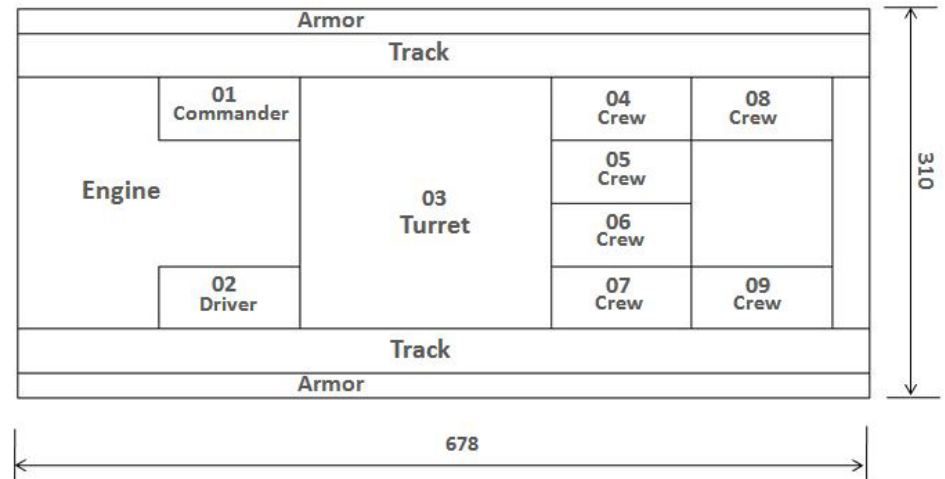

Side View

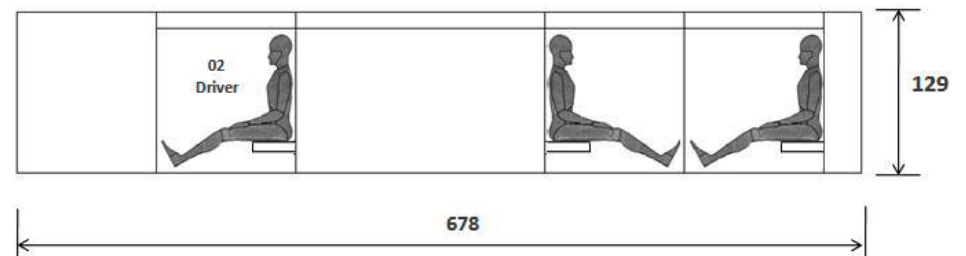
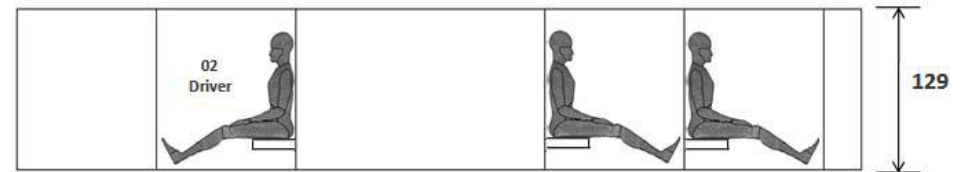

Layout 5

The biggest disadvantage of 2,3,4 & 5 was the Gunner for the turret was never taken into consideration. 4 & 5 had reduced the number of crewmen which was not good. And crew sitting height was decreased to 25cms, which was not comfortable. The Hollow space in the front part of Vehicle was also not considered, which helps in the Amphibious working of the Vehicle. Even the Turret Dimensions were not considered for the height decision.

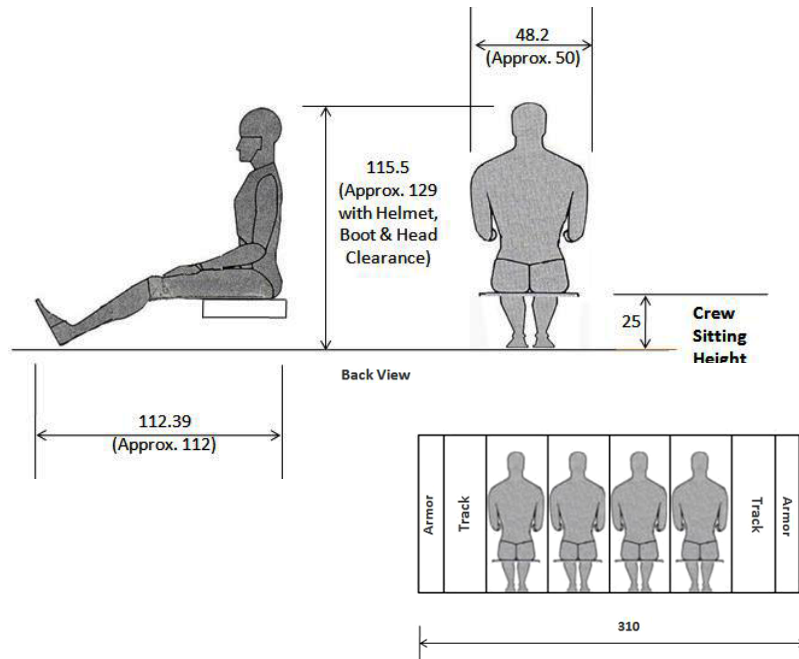

Calculations for 95th percentile male
All the dimensions are in cm

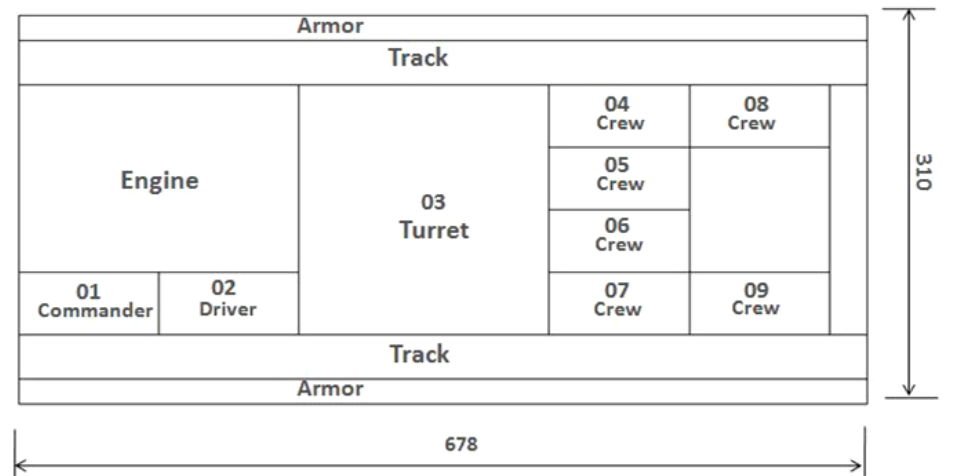

Side View

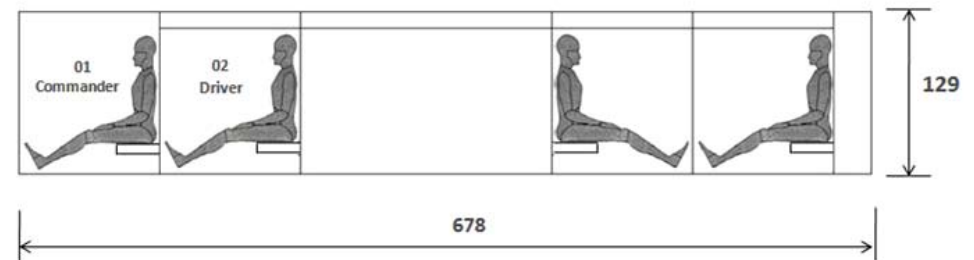

4.5 Final Layout Concept

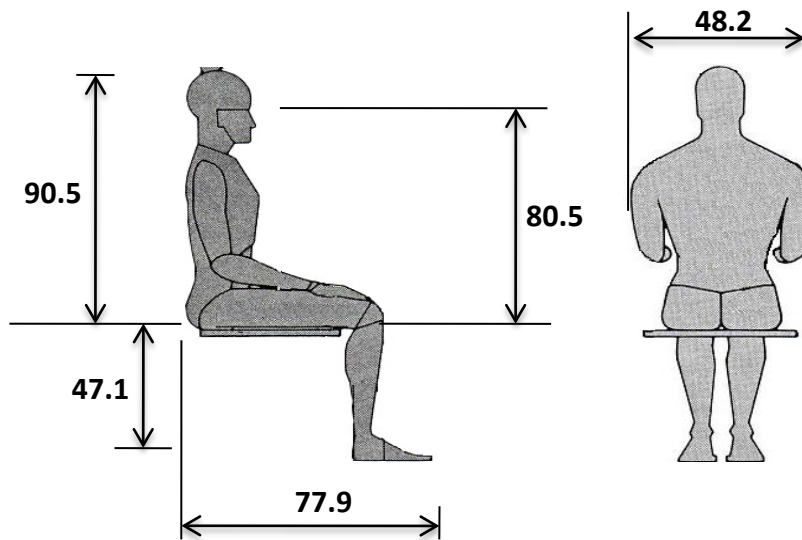

$$\begin{aligned}\text{Seat Height} &= \text{Popliteal Height} + \text{Boot} \\ &= 47.1 + 3 \\ &= 50.1 = 50 \text{ (approx.)}\end{aligned}$$

$$\begin{aligned}\text{Space width for one Soldier} &= \text{Shoulder Width} + \text{Clearance} \\ &= 48.2 = 50 \text{ (approx.)}\end{aligned}$$

$$\begin{aligned}\text{Crew Compartment Height} &= \text{Seat Height} + \text{Sitting Height} \\ &\quad + (\text{Helmet or Turban}) + \text{Clearance} \\ &= 50 + 90.5 + 3 + 10 \\ &= 153.5 = 155 \text{ (approx.)}\end{aligned}$$

$$\text{Buttock-Toe Length} = 77.9 = 80 \text{ (approx.)}$$

$$\text{Seat \& Back Cushioning} = 5$$

Rest of the Dimensional Data are given throughout the final layout Of the ICV.

Calculations for 95th percentile male
All the dimensions are in cm

Final Concept

The final layout started with considering capability of 11 people (Driver + Commander + Gunner + 8 Crew). All the dimensions are given in the layout figure. There is empty space in the front part of the vehicle to have it Amphibious. There is two rows of Infantrymen sitting in the rear part of the vehicle. Driver and Commander are in the left side in the front while Gunner is in the right side. Crew 1 & 5 will be the persons who will be firing Automatic Machine Guns.

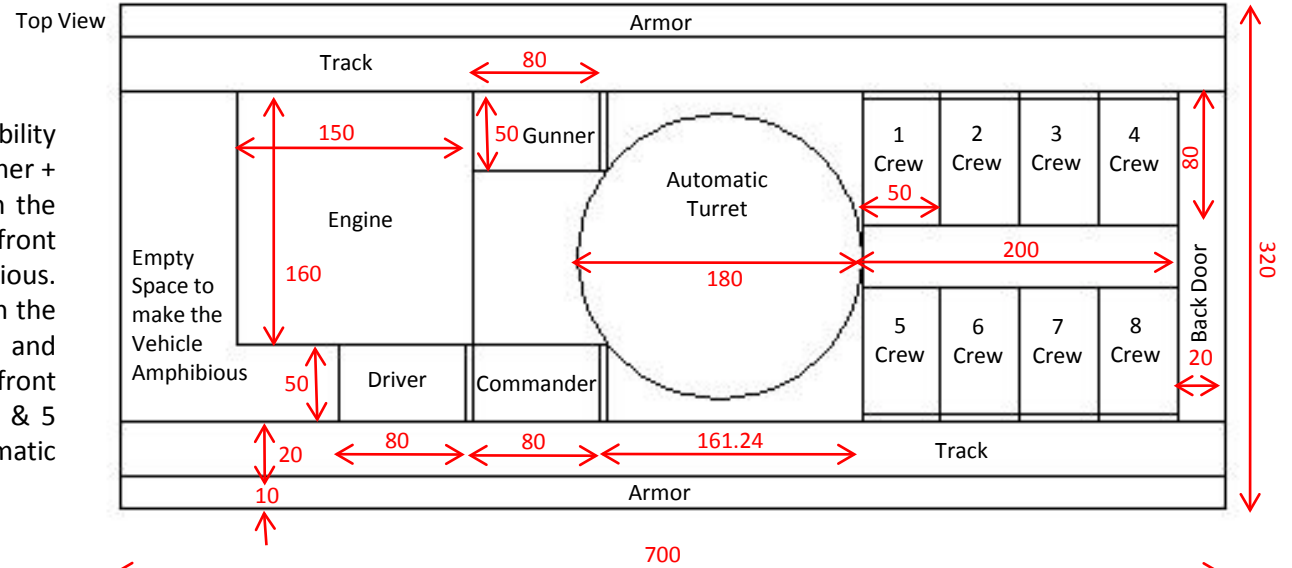

Vehicle:

Length - 700 cm
 Width - 320 cm
 Height - 250 cm

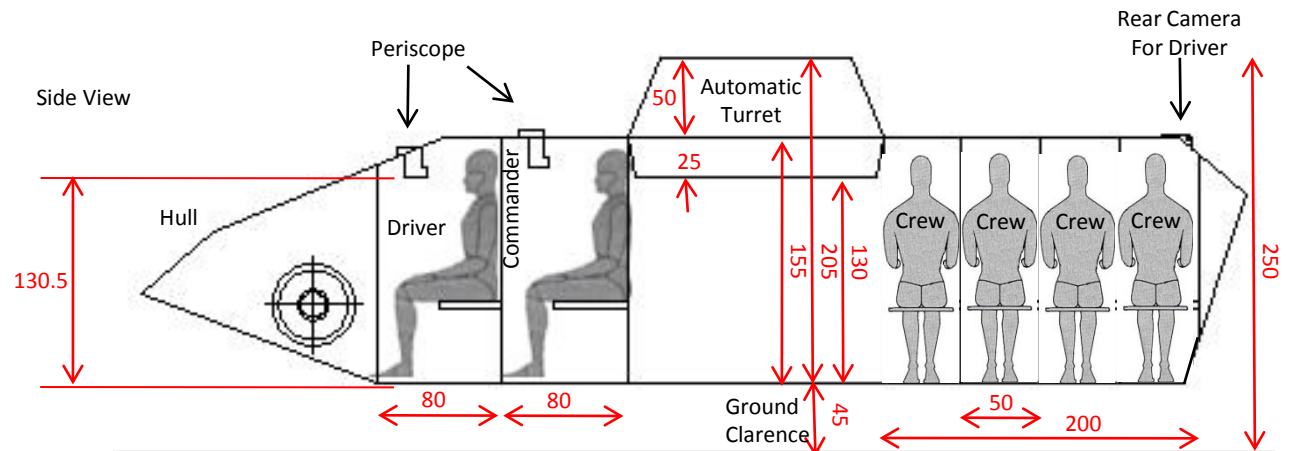

Calculations for 95th percentile male
 All the dimensions are in cm

The crew sitting can be of two types as shown in the figure. Both are good and optimized to its best. But the need to break the fuel tank into two banks lead to take decision in favor of the first.

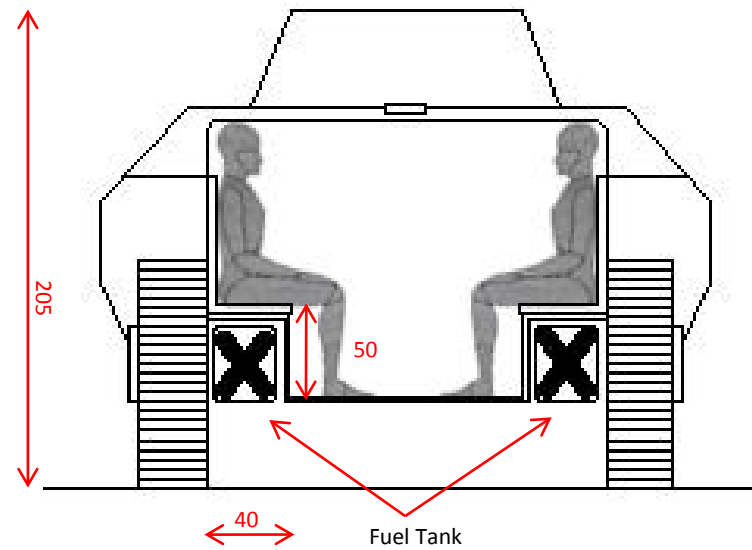
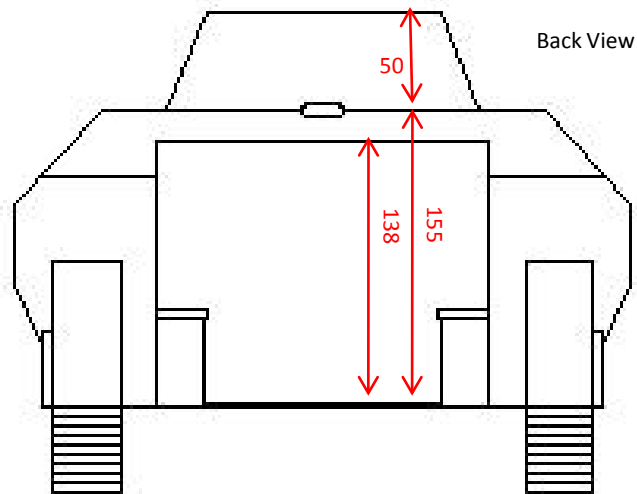
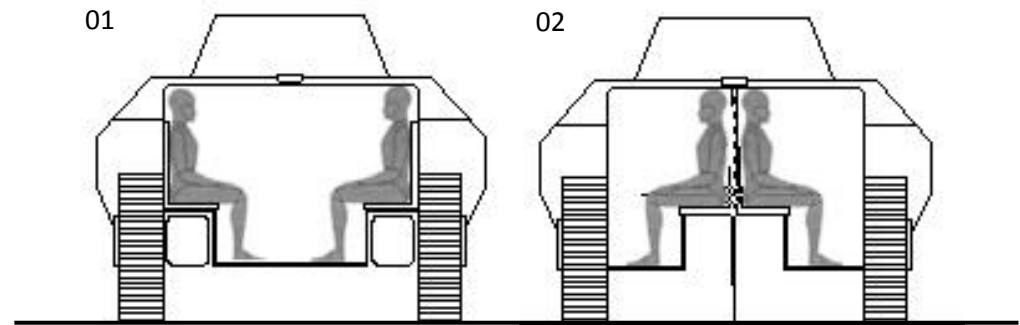

All the dimensions are in cm

4.6 Rig Testing & Changes

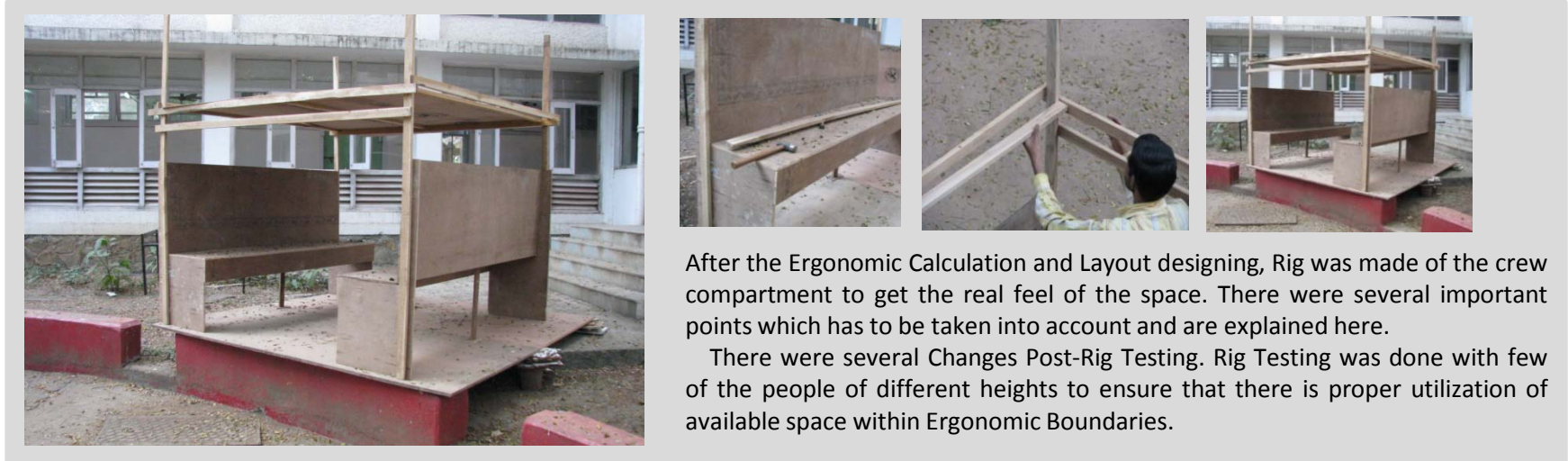

After the Ergonomic Calculation and Layout designing, Rig was made of the crew compartment to get the real feel of the space. There were several important points which has to be taken into account and are explained here.

There were several Changes Post-Rig Testing. Rig Testing was done with few of the people of different heights to ensure that there is proper utilization of available space within Ergonomic Boundaries.



All the soldiers with different %tile were facing problem while alighting the vehicle., they needed something to hold while alighting.

For this problem holding while alighting the ICV was solved by providing a Alighting Rod placed just above the door on the inside.

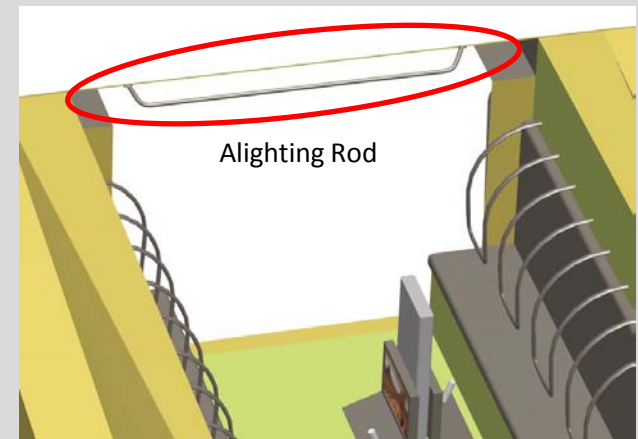



As the whole calculation was done for the soldier with 95th %tile, so the soldier of 50th %tile was facing problem while sitting as his feet was in air. So, seat height is needed to be decreased.

For this case of sitting problem, seat height was decreased from 50cms to **40cms**. Again testing was done with people of all heights, due to presence of extra space in front of seat, height was comfortable for people with all types of heights.



Soldier with smaller height needed some support or handle while climbing the vehicle.

This Problem for the need of having a hold by a soldier of small stature was solved by providing Climbing Hold Rod given on the both sides of the door on the back side.

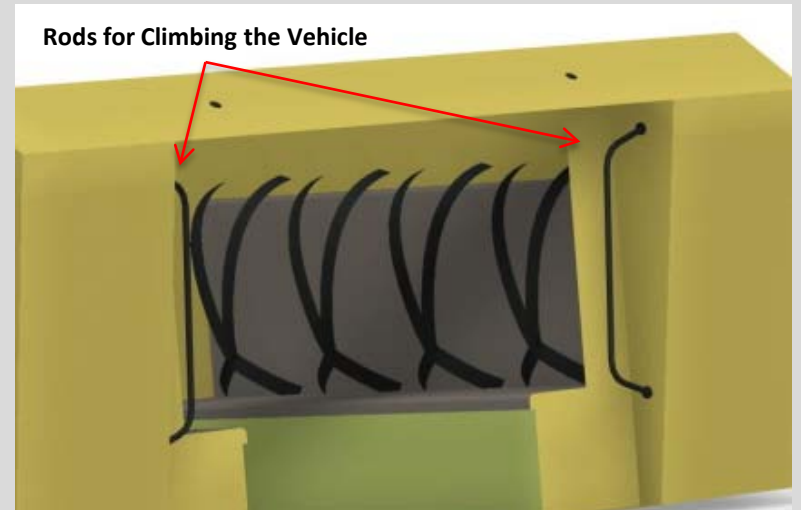

5 Aesthetic & Styling



5.1 AESTHETIC

Aesthetics or esthetics (also spelled æsthetics) is commonly known as the study of sensory or sensori-emotional values, sometimes called judgments of sentiment and taste. More broadly, scholars in the field define aesthetics as "critical reflection on art, culture and nature." Aesthetics is a sub discipline of axiology, a branch of philosophy, and is closely associated with the philosophy of art. Aesthetics studies new ways of seeing and of perceiving the world.

Aesthetic in case of Army is needed for Moral. The Feeling of having a Good fighting Weapon keeps the moral of the Soldier high and of enemy low. Visual Plays a Drastic Effect on the mind. So, Aesthetic & Styling in case of Army Product is also justified.

AESTHETIC

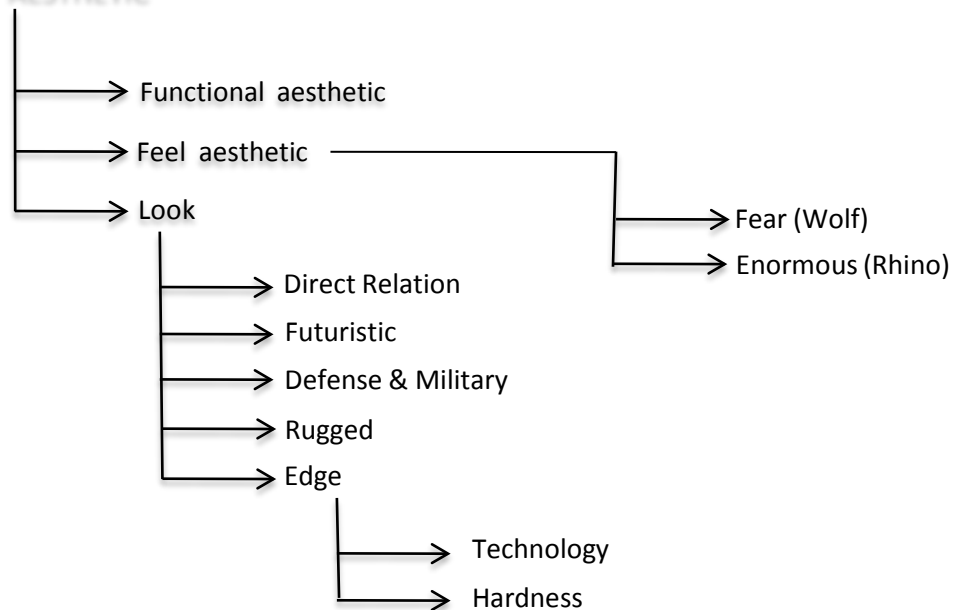

5.2 MOOD BOARD



5.3 Elements of Mood Board

The words that comes out of my mood board to describes my Design are

- **Aggressive**
- **Dynamic**
- **Ferocious**
- **Futuristic**
- **Powerful**
- **Rugged**
- **Protective**
- **Enormous**

5.4 Concept Sketching & Ideas

Rhino

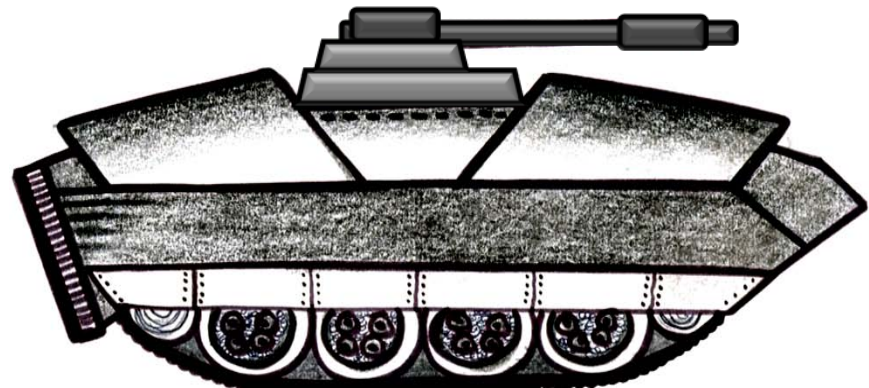
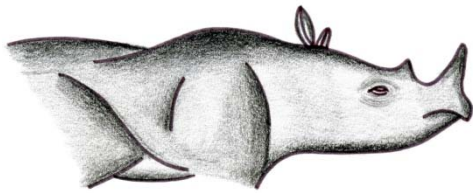

Taking the same elements discussed earlier, these are some various concept sketches which may have direct or indirect notion for styling.

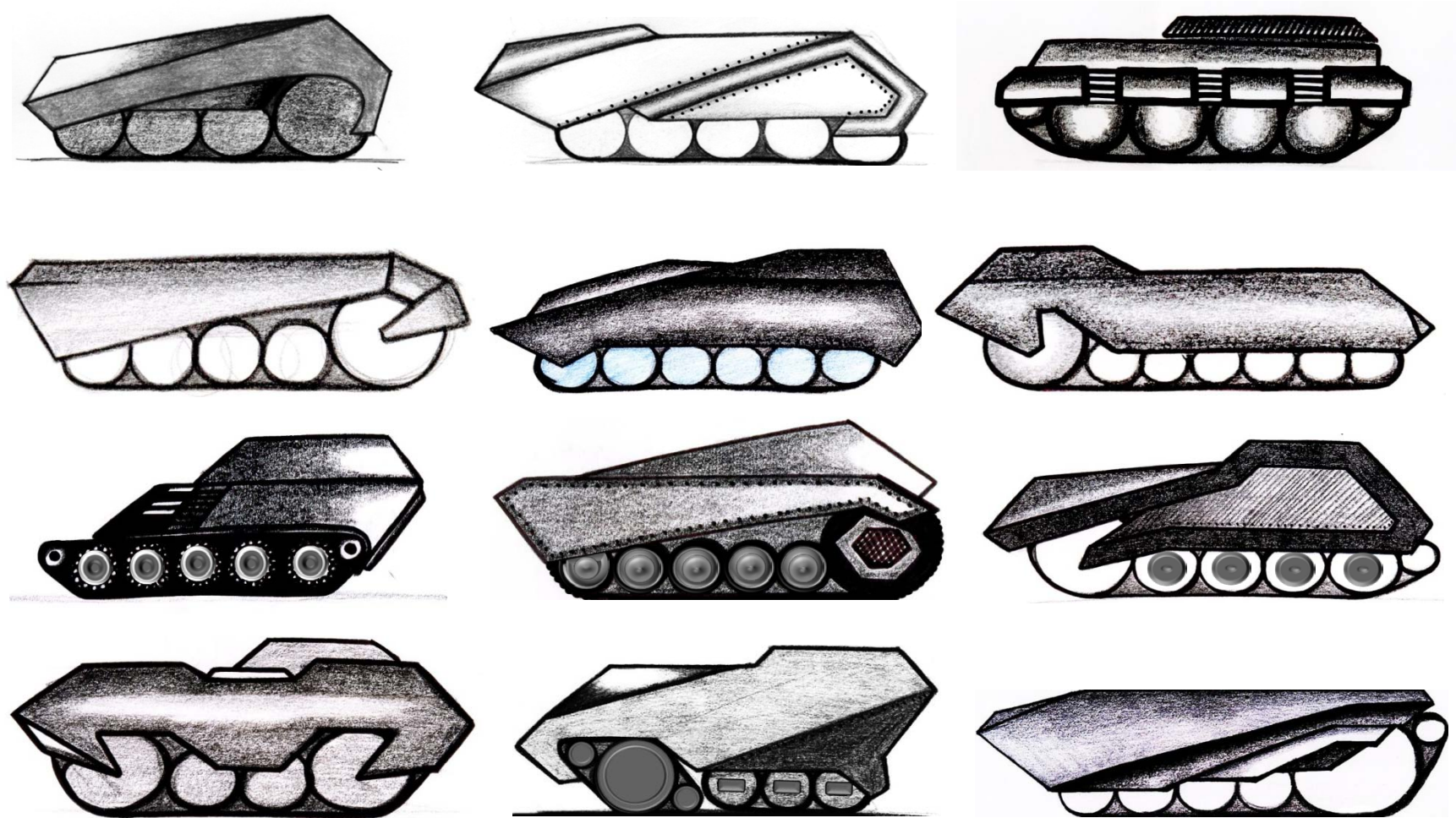

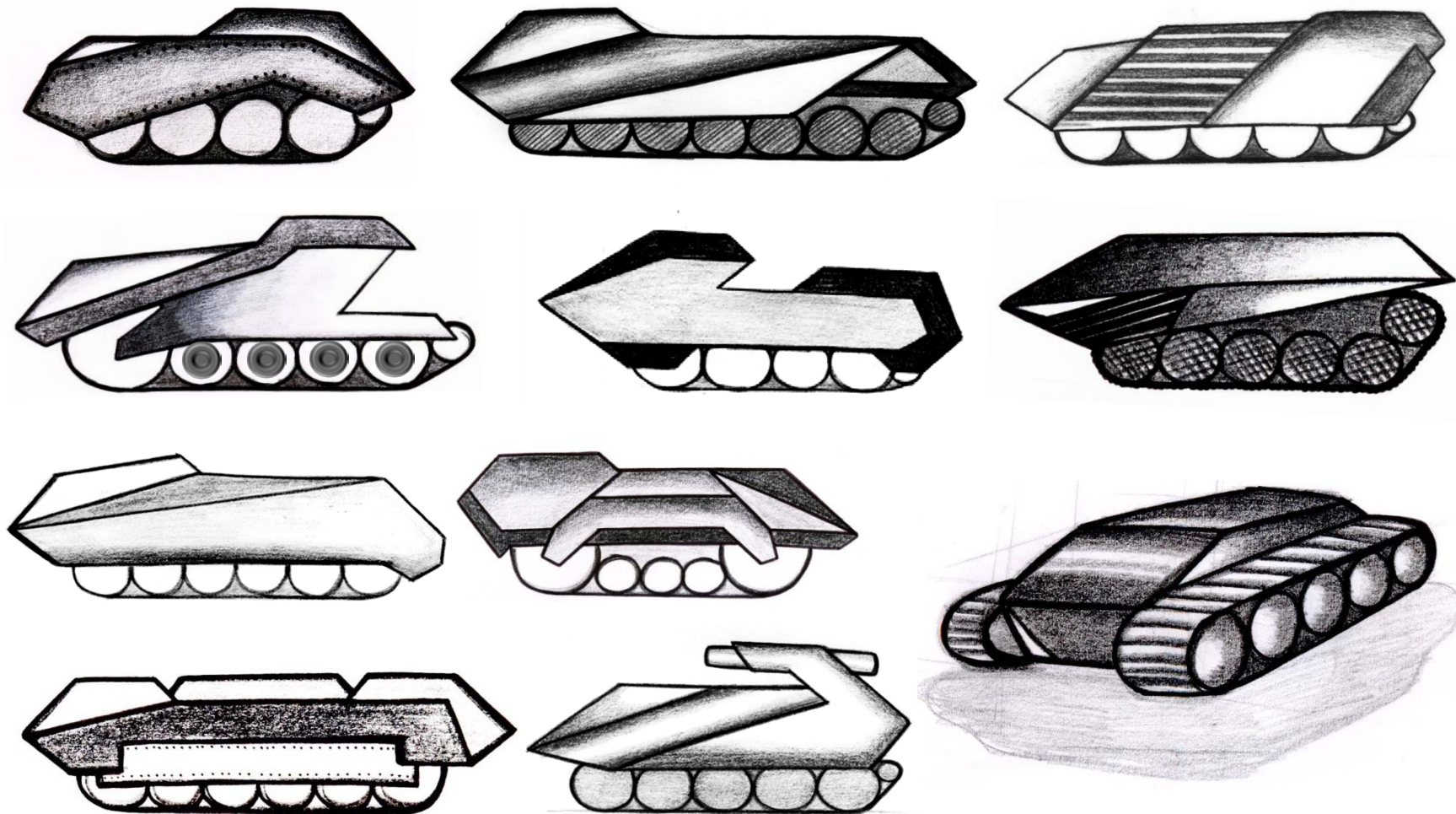



Fear (Wolf) : IMAGE BOARD

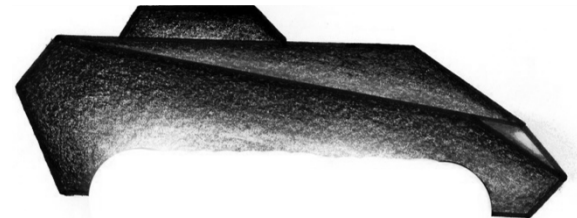
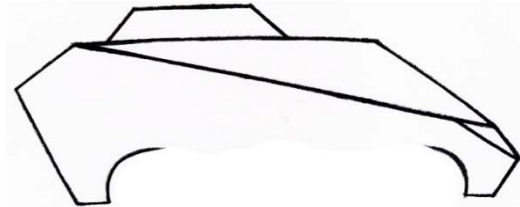
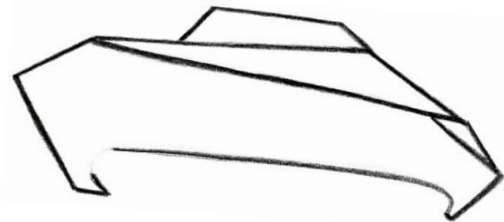
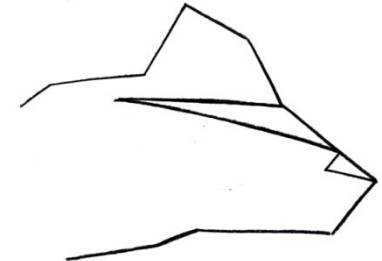
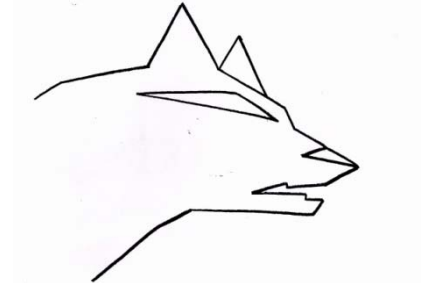
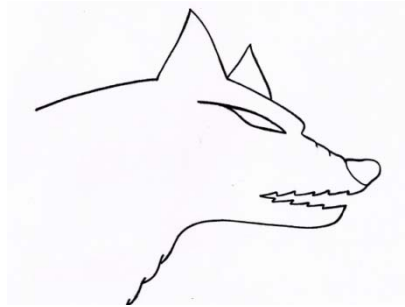

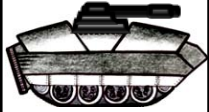

5.5 Selection of Best Concept : After the sketching, 7 out of all ideas were chosen for the voting. It was to be found the which out of the 7 gets maximum vote to satisfy the Mood Board. 6th out of the all got the maximum points. So, 6th idea was chosen for the further refinement. This voting was carried with 20 people and based on that chart has been prepared.

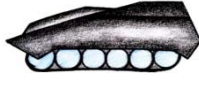
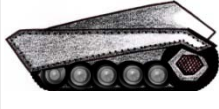
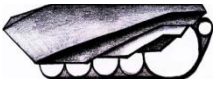
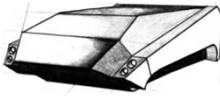
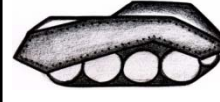
	1	2	3	4	5	6	7
							
Aggressive	4	4	6	7	6	8	5
Dynamic	4	4	5	7	6	9	5
Ferocious	4	4	6	8	5	8	6
Futuristic	2	5	4	8	7	9	5
Powerful	7	6	5	8	6	8	6
Rugged	8	5	3	6	6	6	7
Protective	6	4	4	7	6	7	5
Enormous	7	5	3	8	6	8	5
Total	42	37	36	59	48	63	44

5.6 Exploration & Mock-up Models (Wolf)



5.7 Final Concept Development

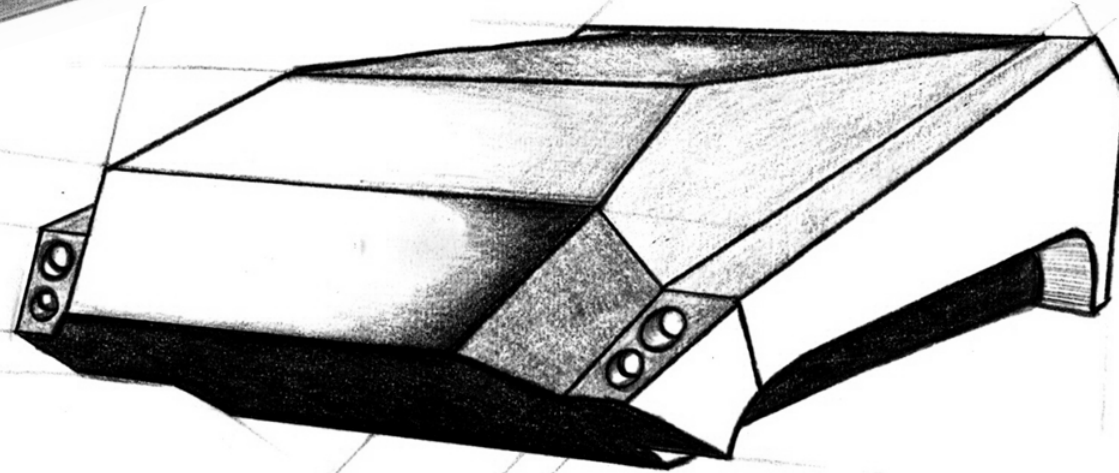
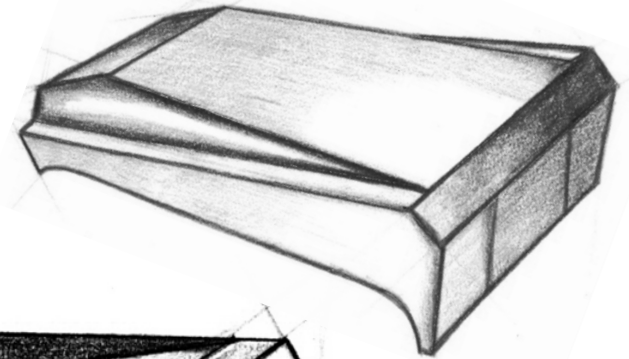
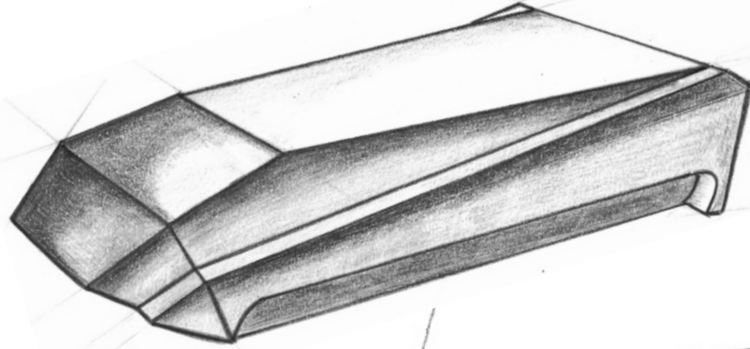
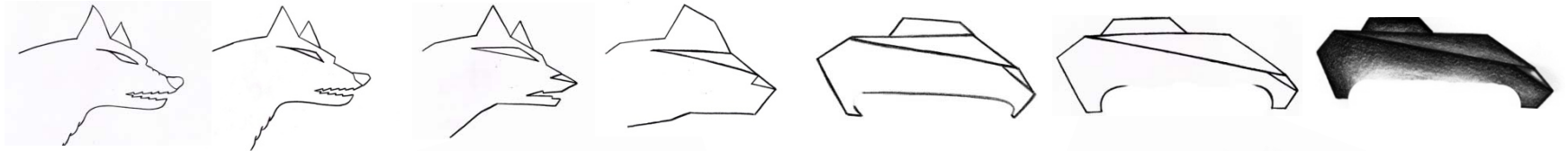

5.8 Designing of the Turret

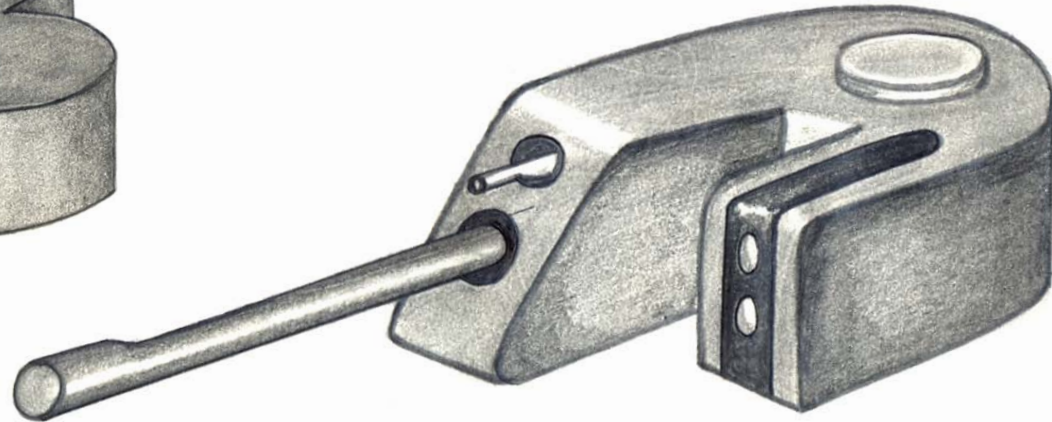
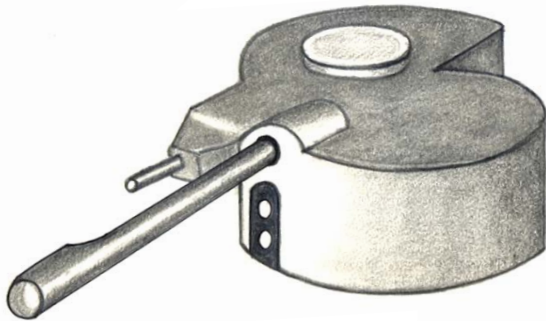
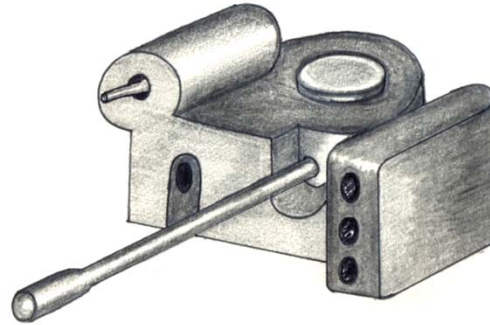
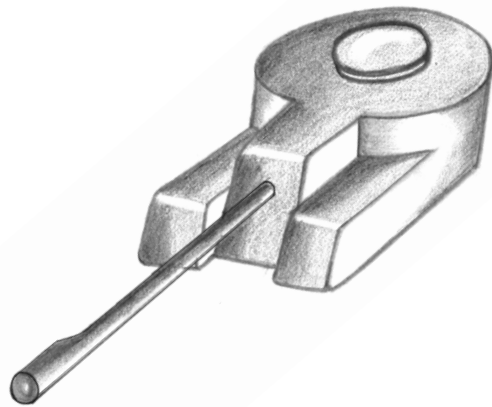

5.9 Final ICV Rendering

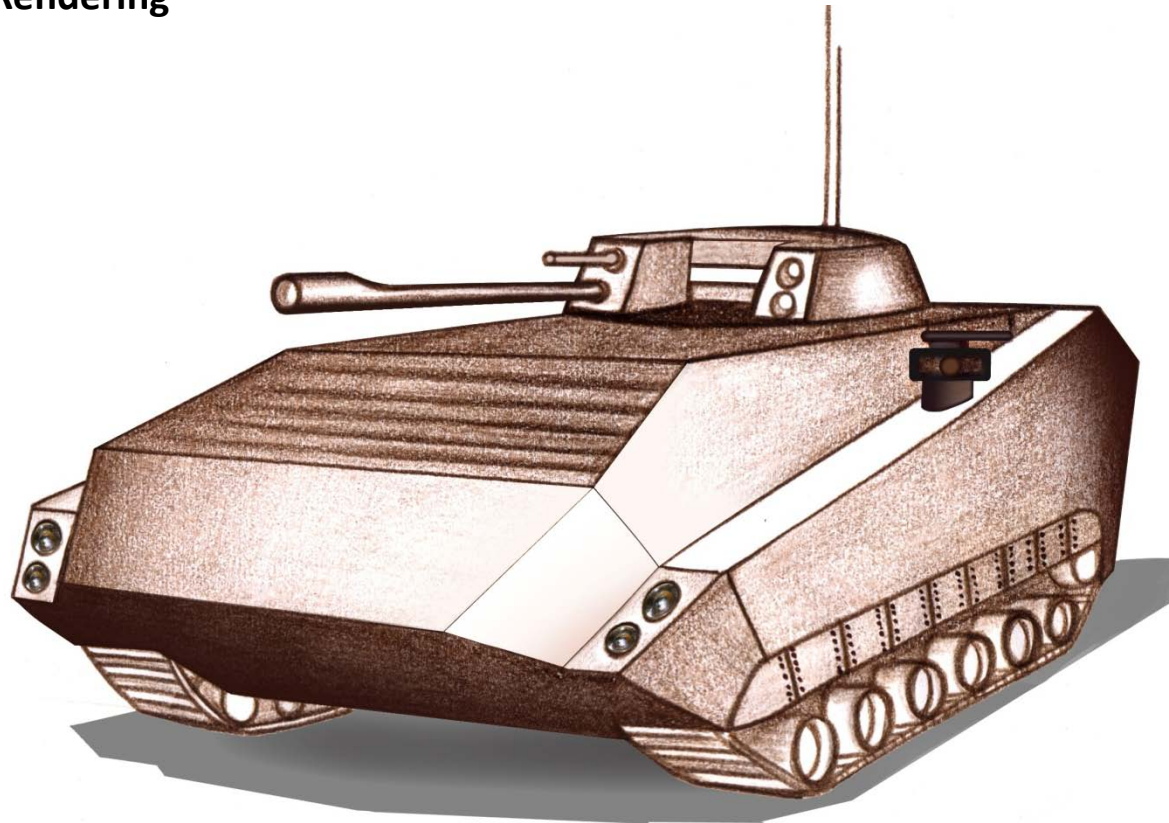

6 New Features to the Design

6.1 Fuel Tank Placement & Crew Safety :

Unlike the other conventional ICVs in which the Fuel Tank is either inside the vehicle or in the door, the new design has two banks of Fuel Tanks., both fuel tanks are outside the Hull of the vehicle.

Now there is a layer of Plastic Explosive in between the Fuel Tank and the surface of the Hull. Now in case of any missile hit or mine explosion, these Plastic explosive will detonate on time and detach the Fuel Tank from the body of the vehicle. This is the same case as that of Reactive Armor.

In case of Reactive Armor, there is a layer of explosive in between the surface of the vehicle and the Protective Armor. Now, when a missile hits the Armor, this layer of explosive detonates and the Protective Armor along with the Missile flies away from the vehicle, thus minimizing the damage.

In the present design, there are two banks of Fuel, in case of explosion its not necessary that both will explode. Even if one is intact, vehicle will work and can be used unlike the conventional ICVs. In addition to these two banks of fuel, one more can be there just below the turret if needed.

As both the Fuel Tanks are outside the Hull, Crew is always safe from explosion of the Fuel Tanks.

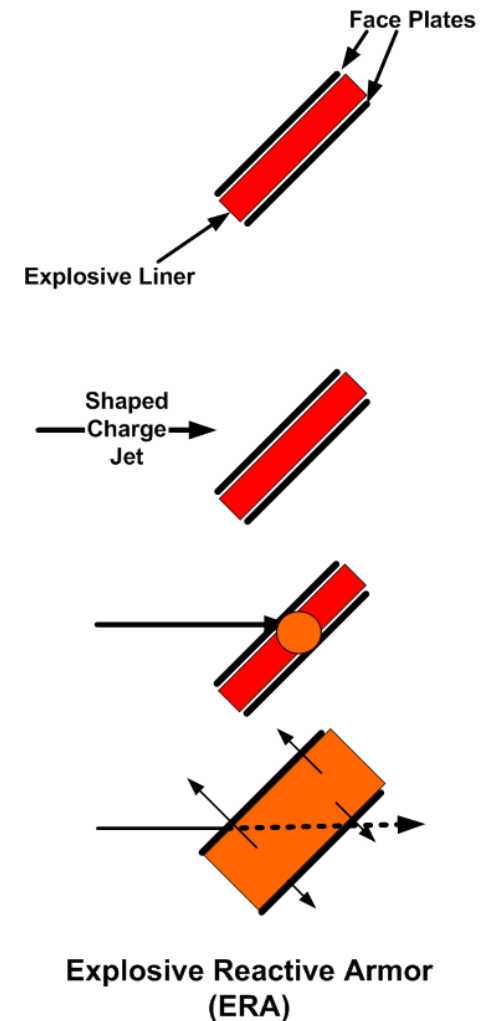

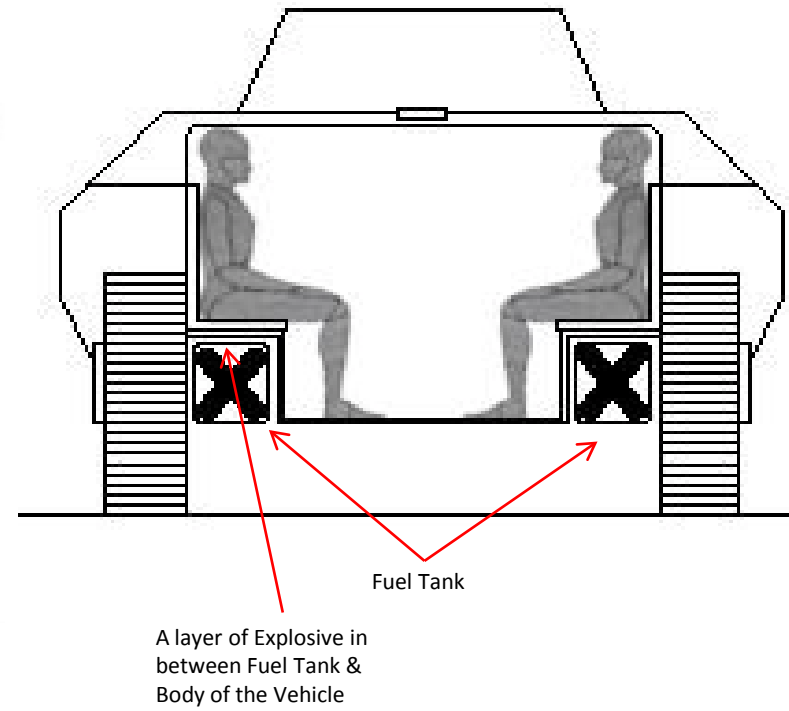
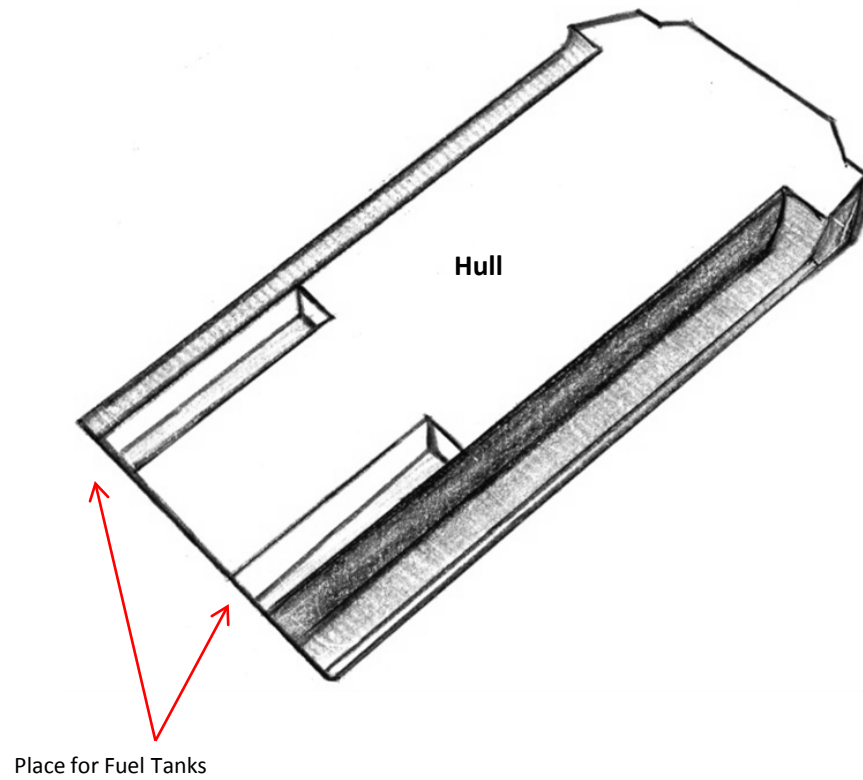

6.2 Unmanned Turret :

Installation of Unmanned Turret to reduce weight. Even as the unmanned turret is small in size in comparison to the old one that BMP-2 uses. So, Vehicle size can be reduced and 60% space below the Unmanned Turret can be used for other new important Installation.

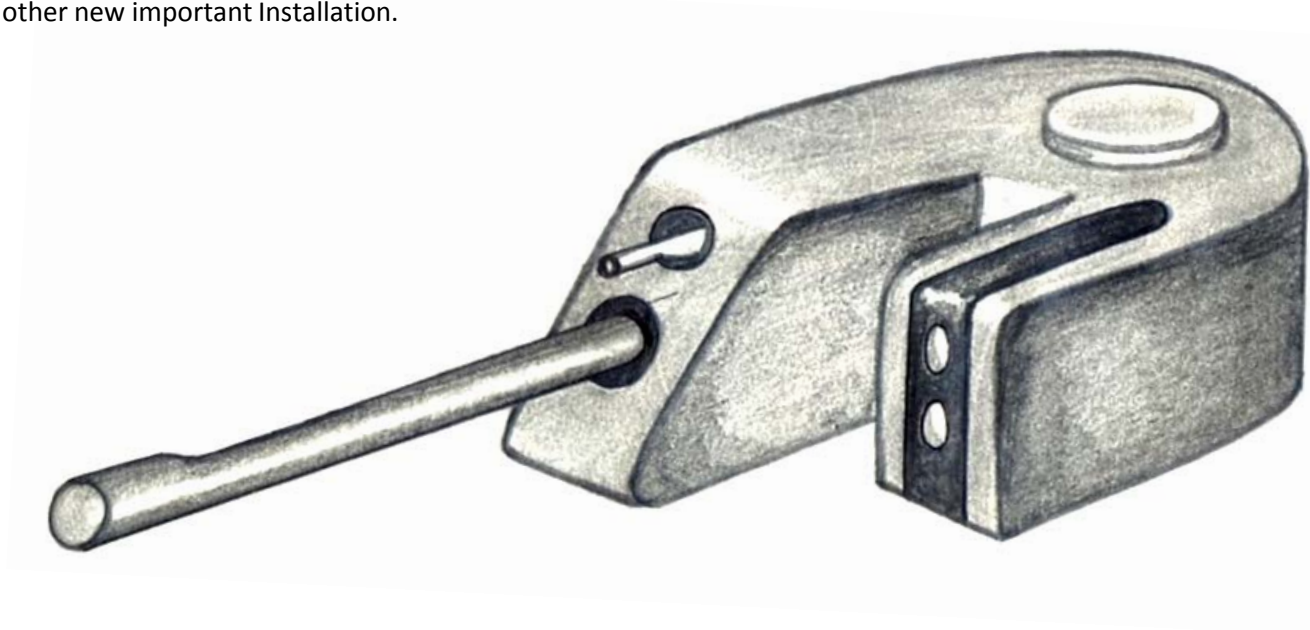

6.3 Use Of Automatic Machine Guns :

Use of Automatic Machine Guns by the Crew leads to better firing on move. Another important point is that the efficiency of two automatic Guns are equivalent to all the Crew Members firing in the conventional ICVs, so there is no need to provide Automatic Guns to everyone. Further as we are using Automatic Guns which can be fired remotely from inside, so there is no need of firing port. Crew is safe from bullets & Artillery fragments in the Battlefield coming through these ports.

The placement of the Control Panel for these guns and its opening is explained through the figure.

Stage 1

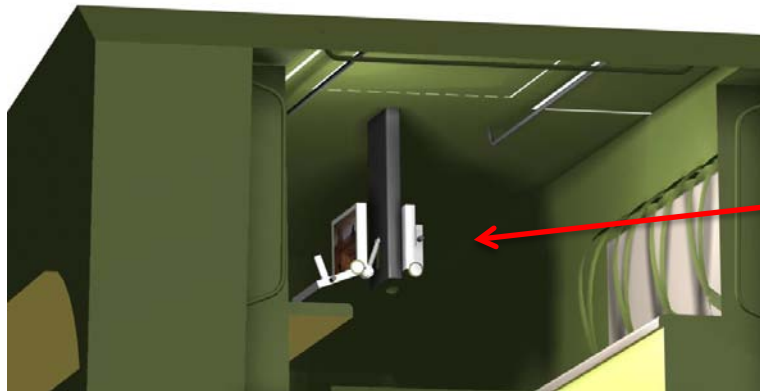

Automatic Machine Guns Firing Control Panel inside the Vehicle, used by the 4th person on the both sides of the sitting.

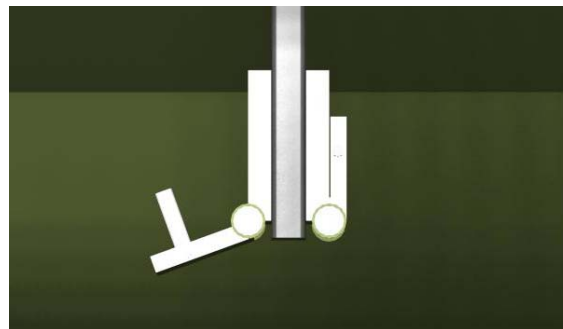
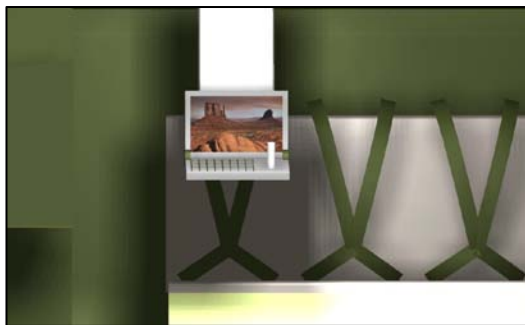
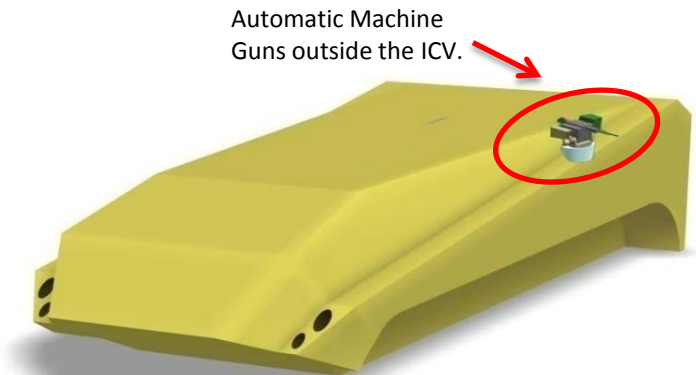

Final Refinement :

The hinges and arms in the earlier design made the display and the keyboard venerable to shocks . Hence, the arms were eliminated and the display and the keyboard were mounted on two separate hinges as shown in the figure.

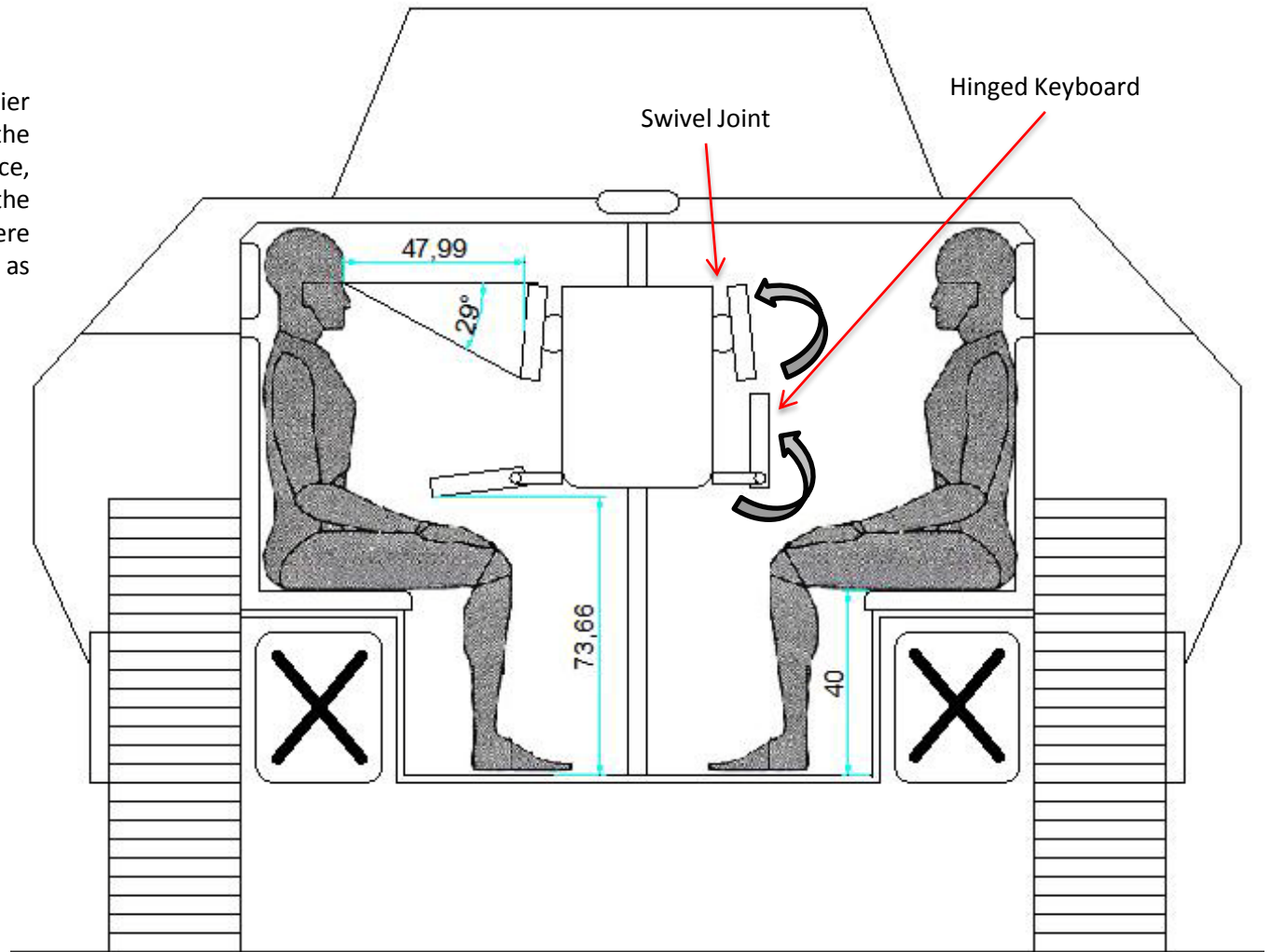

6.4 Sloping Armor :

Use of sloping armor with less thickness, will reduce the weight with increase in protection. Throughout the designing of the vehicle it has been tried to get maximum sloping surfaces so that more and more Sloping Armors can be used. 30-45 degree in the sloping leads to the 10-15% reduction in the width of the Armor.

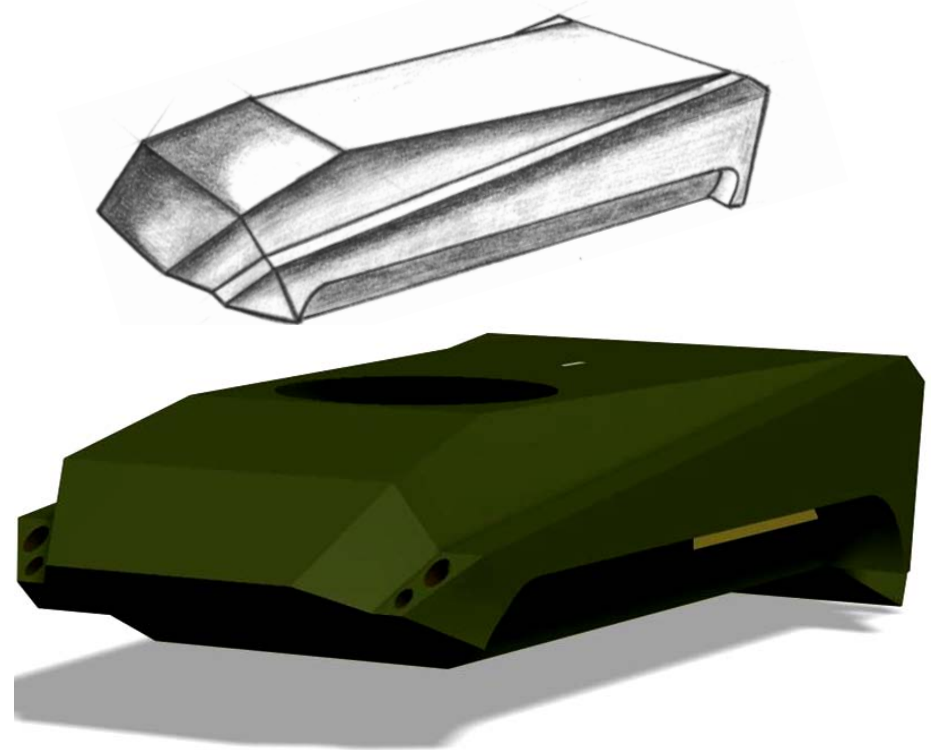
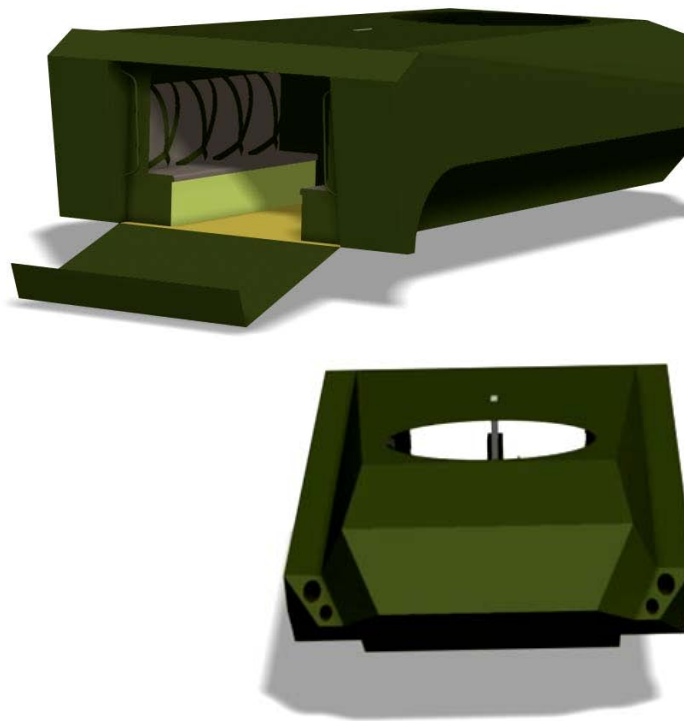

6.5 Instructions Inside the ICV :

All the instructions written inside the BMP-2 Vehicle were in Russian Language. Soldiers in the Army come from different Educational Background, so, in new design, all the instruction will be mostly in the form of Visual Symbols and written Instruction wherever needed to avoid the confusion arising out of Language. Some of the Graphic Instructions created and others are existing one.

New Icons



Seat Belt



Emergency Exit



Fuel Tank

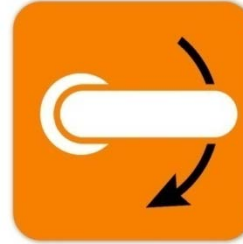

Door Handle

Existing Icons



Repair



Control Panel



Explosive



Flammable

6.6 Harness :

Providing the Seat Belts (Harness) can led to better Firing Capability on move. Even to keep the Crew in place Harness is needed. Here there are two ideas.

Idea 1) First Idea is as shown in the figure. Seats can have Harness just like used in Roller Costar but a bit redesigned.

In case of Emergency Evacuation through Top Hatch, these can work like a ladder as height is pretty big to climb.

Idea 2) One of the Idea is to use 5 point Harness for holding the crew on its place. This is a bit more feasible for a less evacuation time. So, this is considered for the new design.

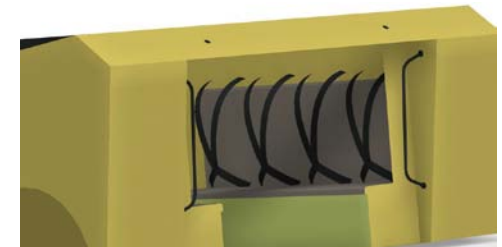
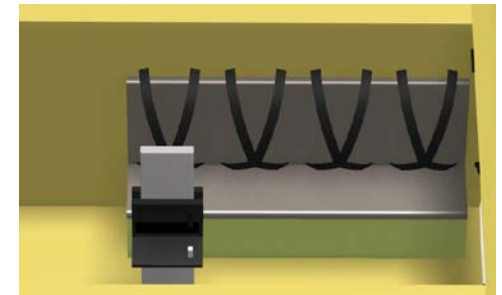
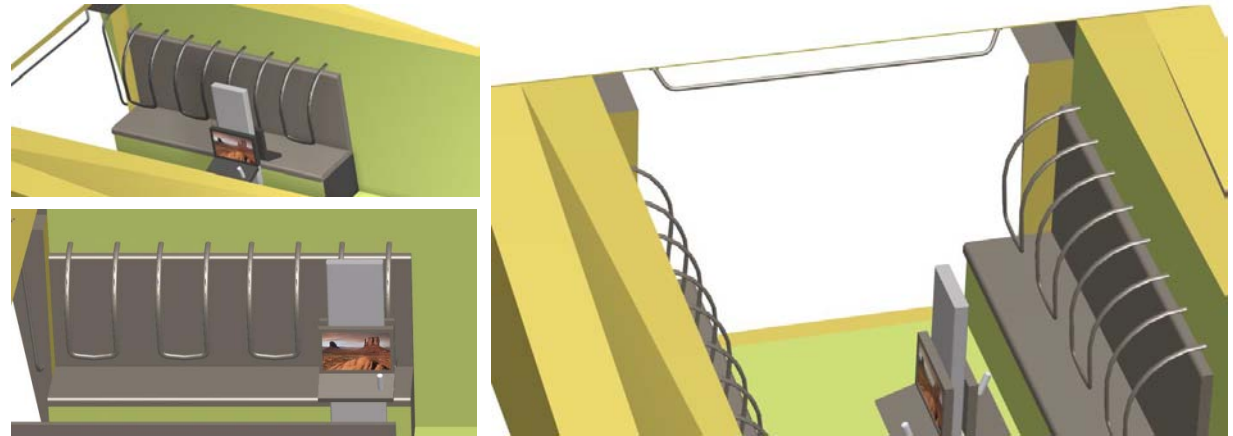

6.7 Use of Better Paint :

Use of better paint can provide better visual camouflaging as well as better IR Camouflaging. This is the first level of protection and should be taken into account carefully. Intermat specialize in special-countermeasure wide-spectrum anti-IR coating materials (400nm - 20000nm) for concealment against thermal observation and deception of heat-seeking missiles. Intermat is widely known for being the only company promoting these state-of-the-art, anti-thermal coating materials that have been developed after many years of R&D.

6.8 Use of Reactive Armours.:

Reconsideration of the Armour Capability. Use of better and new technique, Use of Reactive Armours.

6.9 Control Panel:

Use of better control panel for the driver and the commander can be more reliable and secure. Day by day newer and newer technology is coming, use of these advances is needed. Use of better Control Panels for the firing of Automatic Machine Guns can lead to better result in Battle. Even Driver needs a better Control Panel for better and precise mobility.

Commander needs better control panel to take better decision based on the available data to construct the strategies for the battle.



Figure: 1 – ICV without Thermal Coating
2 – ICV with Thermal Coating



6.10 Cooling of the Crew Compartment :

Heating of the BMP-2 Crew Compartment in Indian Climatic scenario is also of big concern. In case of Rajasthan like areas, due to Engine and out side heat. crew compartment temperature rises up to 58 Degree C. So, there r two ways of cooling –

a) Conventional Air-Conditioning

b) Vapour Absorption based Air-Conditioning

Fitting AC can be a solution but there is another type of cooling systems also which can be applied using the wasted resources of the ICVs.

Vapour Absorption Cycle can be used to get the compartment cooled using the heat of the engine (Electrolux is using this concept).

Advantages of this Cooling System –

- a) In this system only single moving part (a small motor) is there, so less wear n tear.
- b) As there is less noise, so there is no problem of Acoustic Signature.
- c) As this System works on the heat of the Engine, so it also helps in the minimization of the Thermal Signature.

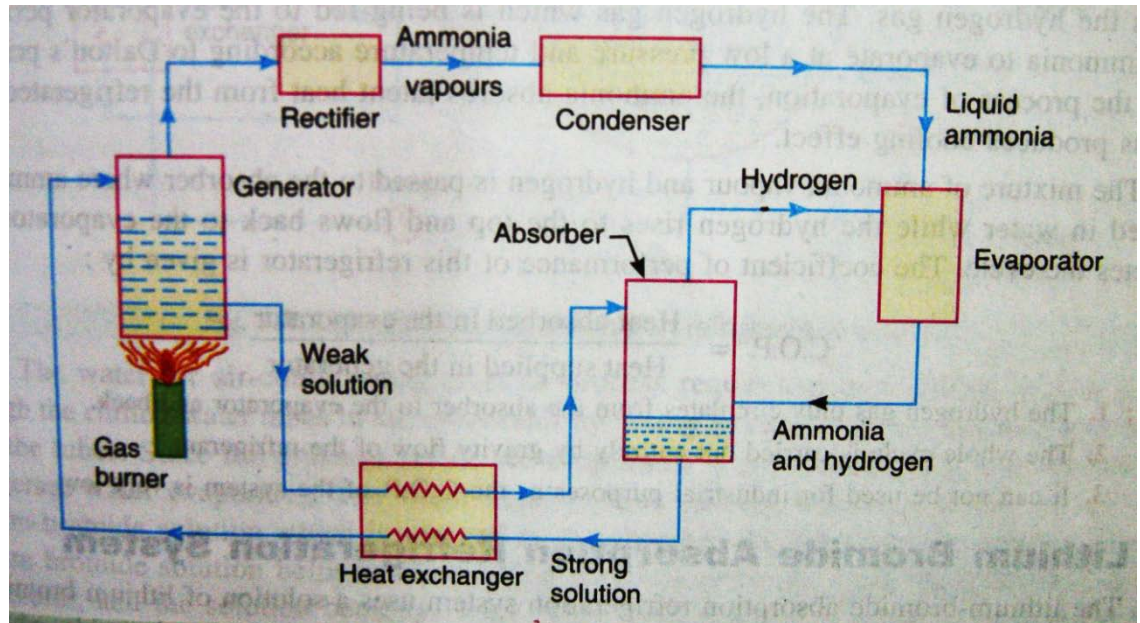

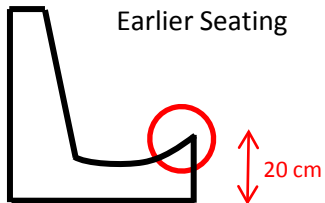
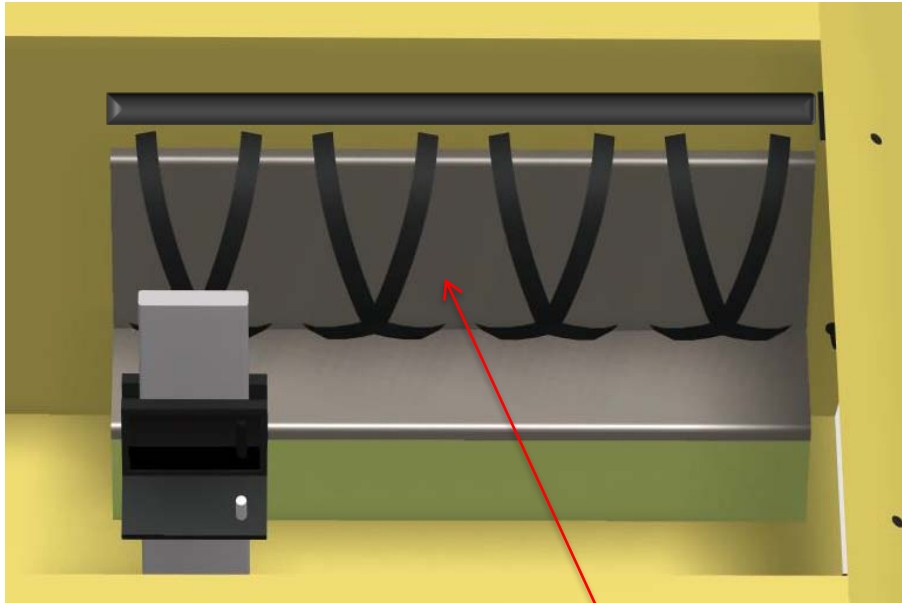

Harness

6.11 Crew Seating :

Crew seating has been analysed according to ergonomic analysis & Rig testing. The final dimensions are shown in the figure. Seats are provided with Harness so that Crewmen are on seat while on move.

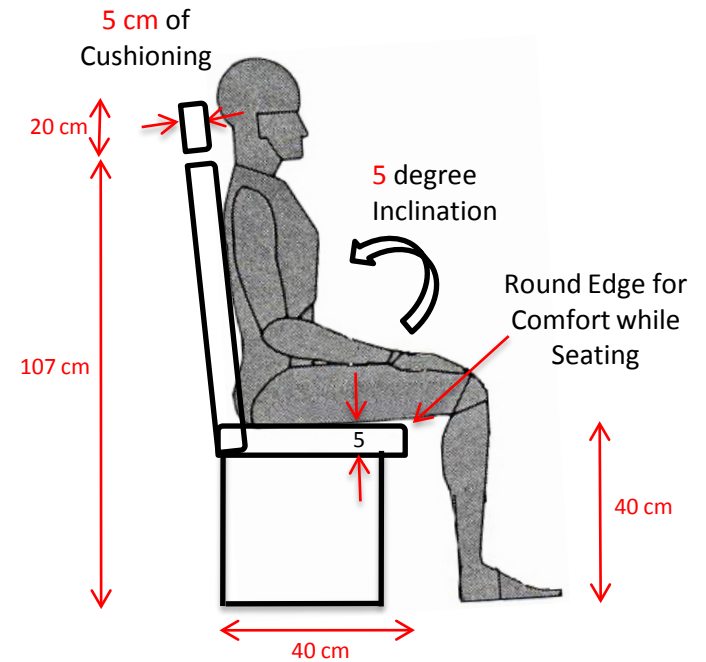

6.12 Emergency Hatch :

Provision of Emergency can be really handy at the time of the Emergency Evacuation or Explosion. In the figure there is a Top Hatch along with Emergency Hatch on the both sides of the ICV.

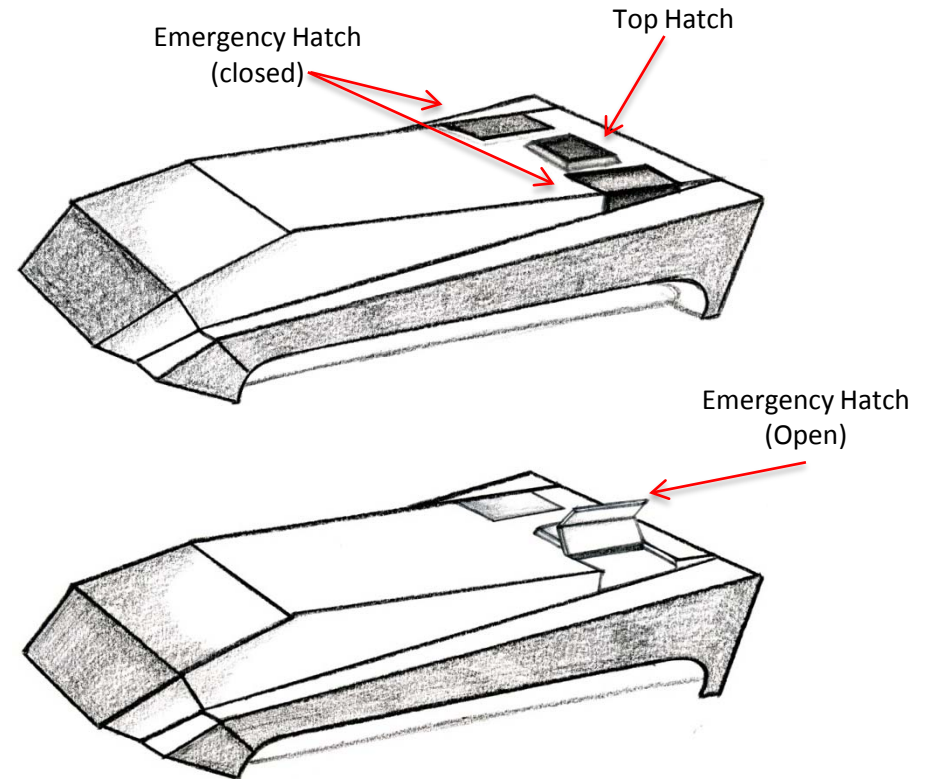

7 Learning :

This project has been challenging as well as a great learning experience. It has greatly enriched my knowledge regarding war scenario and the need for concern towards the usability and user convenience in defense systems. It has further underlined my belief in user driven design. It has made me realize the importance of design as a process towards solving problems be it any field from life critical systems like an Infantry Combat Vehicle to everyday products

References

- Chakrabarti,D. 1997: Indian Anthropometric Dimensions for Ergonomic Design Practice, National Institute of Design, Paldi, Ahmedabad, India.
- Panero,J. and Zelnik,M. 1979 : Human Dimensions and Interior Space, Whitney Library of Design, Watson-Guption Publications, New York.
- Military Technology, Copyright © 2009 Mönch Publishing Group, Heilsbachstraße 26 53123 Bonn-Germany
- Larsen & Toubro Ltd. Powai, Mumbai, India

Websites :

- <http://warfare.ru/?catid=245&cattitle=IFV-and-APC> : Copyright © 1997- 2008 Eugene Yanko 22nd Aug 2008
- <http://www.kurganmash.ru/en/> : © 1999-2009 Kurganmashzavod JSC 24th Sep 2008
- <http://www.strategypage.com> : © 1998 - 2009 StrategyWorld.com 27th Sep 2008
- <http://www.defense-update.com/products/g/gefas.htm> : Copyright 2007, Defense Update 27th Sep 2008
- <http://www.etanks.ws/Littlefield-tank-collection.htm> : © 1992-2008 DC2NET™ 27th Sep 2008
- <http://www.defencetalk.com/forums/showthread.php?t=4451> : Copyright ©2000 - 2009, Jelsoft Enterprises Ltd. 27th Sep 2008
- <http://www.kmweg.de/mediendb2.php?area=4> : © 2005-2008 Krauss-Maffei Wegmann & Co. KG 29th Sep 2008
- http://en.wikipedia.org/wiki/Reactive_armour 29th Sep 2008
- <http://www.rheinmetall-detec.de/index.php?lang=3> : © 2009 Rheinmetall Defence 29th Sep 2008
- <http://www.mapn.ro> : © 2008 Ministerul Apărării 6th Nov 2008
- <http://www.army-technology.com/> : Copyright 2009 SPG Media Limited 6th Nov 2008
- <http://www.globalsecurity.org/index.html> : © 2000-2009 GlobalSecurity.org 19th Nov 2008
- <http://www.inetres.com/gp/military/cv/index.html> : Copyright ©2004-2008 Gary W. Cooke 19th Nov 2008
- <http://science.howstuffworks.com/bradley.htm> : © 1998-2009 HowStuffWorks, Inc. 20th Dec 2008
- <http://blog.wired.com/defense/2008/03/robo-tank-test.html> : © 2008 CondéNet, Inc. 20th Dec 2008
- <http://www.militaryspot.com> : Copyright MilitarySpot.com 1st Jan 2009
- <http://www.defendamerica.mil/archive/2007-09/20070905am2.html> 1st Jan 2009
- <http://www.army-technology.com/contractors/camouflage/intermat/> : Copyright 2009 SPG Media Limited 2nd Jan 2009