

Game design for Kids in a Transit Environment

Industrial Design Project III

Ameya Surve

07613005

Guide

Prof. Ramachandran

Industrial Design Centre

IIT Bombay

May 2009



The Industrial Design Project III titled

Game design for Kids in a Transit Environment

by

Ameya Surve

Industrial Design 2007 batch.
07613005

is approved for the partial fulfilment for the post graduate degree of

Masters of Design
in
Industrial Design

Guide

Chairman

External Examiner

Internal Examiner



Acknowledgements

I wish to express my deepest gratitude to Prof. Ramachandran, my project guide, with whose guidance and motivation throughout the project, I could understand the process and the methodology that goes into making a project successful. Also special thanks to Prof. Athvankar for guiding me regularly and sharing his Game Design experiences with me.

I would definitely like to thank all the other professors at IDC for being open with their regular constructive criticism and their guidance whenever I have needed it.

Special thanks to all the workshop staff who were of the most help while making my final models.

Special thanks to all my batch-mates who helped me in their own little special way to make the learning experience interesting as well as mutual.



Contents

Chapter 1

Introduction to the project

1.1	Need for the project	02
1.2	Toys, Puzzles, Games	03
1.3	What is a Game	04
1.4	Understanding the Gameness of the game.	06
1.5	What are Travel Games	08

Chapter 2

Understanding Requirements

2.1	Design Brief	10
2.2	A closer look at Train Travel.	11
2.3	Experiencing existing products	12

Chapter 3

Ideation

3.1	Game Themes	14
3.2	Board/Base Themes	15
3.3	Gameplay Ideas	16

Chapter 4

Idea Development

4.1	Own the whole World	18
4.2	Formula 1	22
4.3	Knockout	28
4.4	Vertical Limit	31
4.5	Hexagonal Game	34

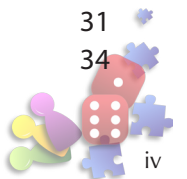

Chapter 5									
Game Attempts									
5.1 Hunt the terrorists	37
5.2 Environment game	39
Chapter 6									
Evaluation	41
Chapter 7									
Final Products									
7.1 Vertical Limit	44
7.2 Knockout	45
7.3 Own the World	46
References	47



Chapter 1

Introduction to the Project



Need for the Project

People travel for a variety of different reasons. These reasons vary from long outings spanning a few days to short visits which might span a couple of hours. Sometimes the route being travelled upon is known to regular travellers or sometimes the route is absolutely new and full of surprises.

Mostly it is observed that adults as well as children sleep during a train journey. Sometimes journeys last for more than a few couple of hours and only sleeping is not enough as an activity to indulge in. So travelling individuals entertain themselves with various other activities, like playing games or reading newspapers or lose chatting.

The idea was to develop a game (or more than one game), which would make travel much more fun and entertaining. The game(s) would be aimed at children, to be played with adults and would necessarily improve child parent interaction, which is generally missing in today's fast-paced world.

Games stimulate the mind and allow the players to participate to win. With repeat play they can master the technique and thus make their playing experience better. Sometimes knowledge games also help in understanding the applications of some fundamental concepts, which don't seem to be understood through the conventional learning processes followed in school.

The idea was to develop a game, which would be given preference during travel over activities like sleeping and reading.



Fig. 1.1: Reading and sleeping are the major activities during travel



Toys, Puzzles and Games

Generally it is found that there is a discrepancy between the terms toy, puzzle and game. All the terms have been defined below.

Toy:

A Toy is defined as an object, often a small representation of something familiar, as an animal or person or thing, for a single child or others to play with; plaything. A toy is usually for kids upto the ages of 3 or 5 years (a few like Lego building blocks being an exception), and is generally played by a single individual. Very less or absolutely no interaction is involved with the surroundings or other people.

Puzzle:

A Puzzle is defined as an object, which perplexes a person and makes him think and use his knowledge to reach the solution (especially, a toy or a problem contrived for testing ingenuity). A puzzle is a simple or complex ensemble of components which have only one unique solution or some fixed number of solutions. Again this involves absolutely no interaction with the surroundings and is restricted to a single person.

Game:

A game is defined as a competitive activity involving skill, chance, or endurance on the part of 2 or more persons who play according to a set of rules, usually for their own amusement or for onlookers.

Lets look at the Game in more detail.



Fig. 1.2: Toys

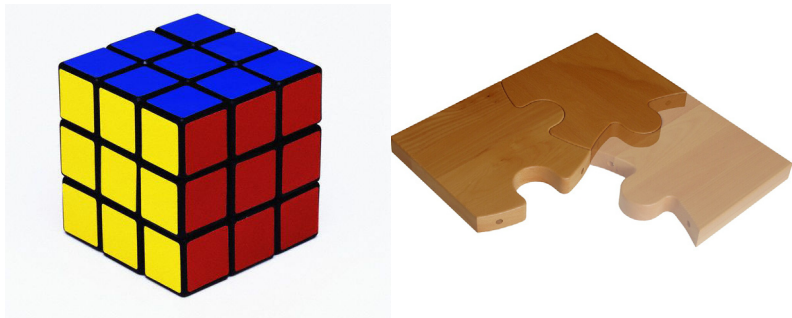

Fig. 1.3: Puzzles



Fig. 1.4: Game



Play
Rules

Strategy.

Element of fun

Winning

Gaining

Luck or chance

Unpredictable

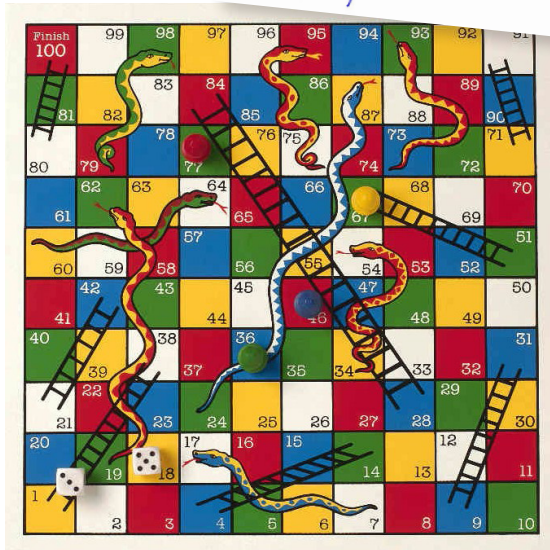

Fig. 1.5: Snakes and Ladders

What is a Game.

A game is an activity which involves play between two or more people. This activity of play usually stimulates the mind to think and react accordingly. This stimulation of the mind usually depends on the rules and the strategy that the game allows.

A game has a set of **rules** which, usually binds the opponents to act in a specified way to play the game. This is decided during the design of the game and is known as the game-play. The rules though always do not decide the course of the game. There are also **strategies** and different approaches to the same solution. The rules are more of an initial constraint to player behavior and later become a part of the subconscious. It is required that every game when played by its rules and strategies should involve an **element of fun** and entertainment for its players.

A game primarily involves **winning** as its ultimate goal. One amongst the players of the game wins and the other (or others) lose. The game might involve a start and a finish (just like a race) with the first person to finish generally winning the game. There are also some games which depend more on the players gaining through the game, the **gains** could be in various units (points, wins, money, no. of hits, etc.)

The winning or losing in a game strongly depends on the strategy used by each of the players and the player with the superior strategy wins. But then it is not always necessary that a game may feature a strategy based approach. Games which are usually **luck or chance** based are more **unpredictable**. The unpredictability of a game makes it even more fun to play. The chances of the game being played consecutively or repeat-play is greater.



Role-Play.

Creates a bond.

Educational Games.

A game sometimes also includes **Role-play**. Games like Scotland yard involve detectives finding a mysterious secret agent. Some of these games have a following and most of the children like such games as it involves taking control of a profession which is unknown to them. These games may also be played by children to know more about the profession and probably later choose it as their career, Eg. Doctor, Business or property trading games, etc.

A game generally **creates a bond** with the opponent. Games for children generally are known to improve friendship and create a strong bond between the two players. Each person knows the others strong points and weak points as well as knows how well they can work together as a team. Some multiple player games also involve teaming up and working together towards a solution.

Games also have an **educational viewpoint**. Games based on certain situations or on various types of activities involve not only entertaining the players but also involve educating and informing them. Some games are also specifically designed with the intention of learning school curriculum without books.



Understanding the 'Gameness' of a Game.

The Gameness of every game depends on a number of factors. These are as discussed individually below.

The main feature of a game would be the **entertainment and fun** aspect of the game. This needs to be built into any game. A game should necessarily put a smile on your face when you are done playing it. A game is primarily played for entertainment purposes and that should always be fulfilled in the game. There are various types of games, but finally it depends on every individual and their personal choices as to what they find entertaining.

Playing a game is mostly a social process. It always includes **interaction with your opponent** and generally involves some onlookers. Some games allow **onlooker involvement** making the gaming experience more friendly. Games for children are known to be a medium for **bonding** after fights or even a platform to get introduced to new friends.

The feature of a game to reach a decision about one person or one team being **superior** to the other is what drives a game. Some games also induce repeat play because the losing side feels that if given another shot they can perform better and also win. Some games might be based on gains, where the person with the **maximum gains** wins. This is not always obvious or instantaneous and may be revealed later after evaluation only.

The playfulness of a game would generally refer to how many times the game is played before the players lose interest in the game. Games of longer duration and involving strategy might not always have a high **repeat-play** value, whereas those with a factor of luck and medium or very little strategy along with short duration might induce more repeat play and could be called more **playful**.

Entertainment and Fun.

Interaction with your opponent.

Onlooker involvement.

Bonding.

Superiority.

Maximum gains.

Repeat-play.

Playful.



Luck or chance

Unpredictable

Strategy.

Degree of Problem solving.

Control.

Uncertainty.

Duration.

The factor which is very important in every game though is Luck. **Luck or Chance** makes a game **unpredictable**. This factor combined alongwith a certain combination with Strategy provides a new feature to each game. Mostly games for young children till the age of 3 could involve very little strategy and a huge factor of luck, while for elder children, from ages 3 to 12 can involve an increasing level of strategy that is required.

Strategy is of many types too. Some games involve strategy during their initial setup, the way you setup the game defines your progress through the game. Some games though involve the use of strategy during the entire course of the game. While some games involve strategy to simply win the game at the last stage.

The **degree of problem solving** also decides the gameness, a high degree of problem solving type of a game may not always appeal to users who are of a lower age-group. On the other hand if the degree of problem solving is too low then the game might not appeal to elder kids as well as their parents who usually satisfy the commercial requirements.

The players should be able to have a **control** over the game during the game play. This feature allows the players to get to what they want to achieve during the course of the game. The players should be able to add a certain amount of **uncertainty** to the game by being able to change the tension for the opponent in a game.

Games are for various **duration** and vary from a few minutes to even days. But finally every game should feature a certain learn-ability so that over a period of time the players can develop a certain expertise.



What are Travel Games?

Travel Games as the name suggests are the games which are played during travel. These games are generally known as travel editions.

Travel editions are usually shrunk versions of existing games or existing board games which have been modified to suit the travel environment. The modifications are generally seen in the form of magnets or notches which are used to counter the movements succumbed during travel.

The packaging systems are also revisited so that they look more attractive while at the same time being completely functional giving the required information. Travel editions do not contain as many literature leaflets as may be contained in the regular game. The rules and regulations of the game and other details are part of the packaging either printed on the packing or stuck to it.

These games generally feature a retaining edge which restricts movement of the game hardware during the movements encountered during travel. This edge actually is the snap-fit edge which is part of the packaging of the game.

The last few years have seen an increase in the travel games on offer, but the same games are marketed as travel games with slight modifications.

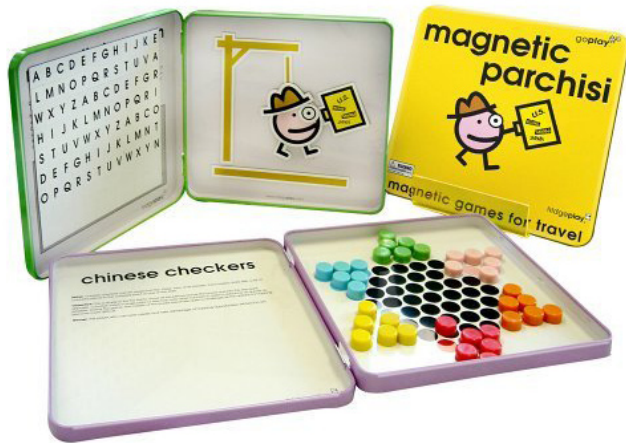

Fig. 1.6: Some examples of Travel Games

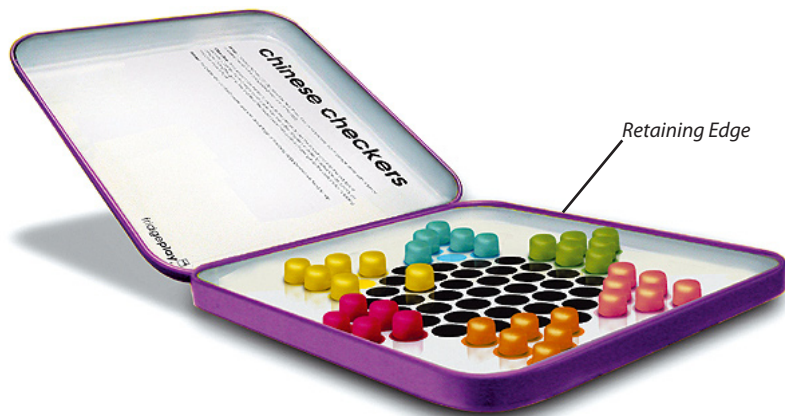

Fig. 1.7: Packaging in a Travel Game



Understanding Requirements



Design Brief

To design a game to be played by two or more players of ages 8 and above, during short or long distance train travel.

The game should be easy to learn and equally easy to play but should not last for more than 30 minutes unless it has a level of challenge involved. It should be lightweight and be packaged to be small enough to be carried during travel. It should also compensate for travel related motion during game-play and ideally involve minimum hardware.

The game should feature opponent interaction during play and also attract an onlookers attention without any direct involvement in the game. It should be durable but comparatively inexpensive to manufacture.

The game should feature luck and chance with being unpredictable and a there should be a strategy required to progress through and further win the game. It should also include a certain show-off value to the winner and thus induce repeat play.



A Closer look at Train Travel

I had a chance to interact with some of the parents during a train journey and the answers given by them showed neglect towards doing anything else in the train other than sleeping, eating, chatting, reading and antakshari.

Most of them were very persistent of the fact that trains today are crowded and entertainment is last on the minds of people, when they have their belongings to worry about. But there were those who felt the need for entertainment in long journeys.

Most of them said that kids generally find their own way of keeping themselves busy during train travel and if given the window seat, this process is accelerated. Parents were of the understanding that games were generally for play at home and the only games to be played in the train could be card games or antakshari. But when told about the prospect of travel games they too showed interest.

Some parents were very specific about the fact that travel games should be educational and should have a learning value to them. Kids on the other hand wanted games that were more fun to play and had a show-off potential to boast to their friends about winning.

Space constraints in the train do exist but things can be accommodated also. So designing a game with a minimalist approach just for travel purposes didn't seem ideal, on the other hand a very lavish game also wasn't ideal for the situation.

Some of the user comments are mentioned herewith.

"Arey bhai, rush kitna hota hai, kuch bhi kaise khalega, baat karne hain sirf!!"

"Train mein sirf 'patta' khelneka"

"Bus enjoy hona chahiye, sab saath baithke enjoy karne chahiye."

"Long train journey mein koi interesting aur naya game hona chahiye"

"Snakes and ladders, Ludo aisehi games travel ke time khelte hai hum log. Thoda jyaada, intelligent log ko chess khelte dekha hai."

"Mere bacche mindpower ke games khelte hain, aur kuch intelligent aur challenging game chahiye!!"

"Agar sirf bacche khete toh enjoy kare, aur bade bhi enjoy kare."

"Bacche idhar udhar dekhte hai, khidki ka seat deneka"



Fig. 2.1: Some views of train travellers and the space available in the II AC train compartment



Experiencing existing products

Before starting the process designing a game, there was a visit to the children's section to see what games are available currently. There was also a look at seeing some travel editions of existing board games.

All the types of games from puzzles to board games to challenge games were tried and tested. During playing them various factors as to the gameplay, the strategy, the luck factor involved, the chance and initial and final conditions were studied. Features like what makes it better than the others were looked at and its USP was understood.

The games played included, 6 puzzles, 8 board games and a challenge game. Moreover I also had a chance to attend the game design module by Prof. Athvankar and also interact with and play all the new games developed during those two weeks. A critical evaluation of these games was also done to point out problems to be attended and thus the games were bettered.

This exercise helped me extensively because it gave me ideas of what is in the market, what sells and how it needs to be designed. This done I started ideating for my game designs.



Fig. 2.2: Funskool Game of Life



Fig. 2.3: Various other games and puzzles from Funskool and Dr.Wood



Chapter 3

Ideation



Game Themes

Initial brainstorming involved ideation of game themes. Various areas were looked at to arrive at game themes, ranging from the inputs given by the students during the user study to the current events to various other fields of interest to individuals. The following are some of the game themes that came up.

Environment Game

Vocab/Logic Based

Business/Stocks game (girls)

Strategy based.

Educational - History, Geography.

Construction Based.

- Environment Game.
 - A game based on the environment, so that students can take the learning from the books and apply it in a playful more application based situation. There was a concept of green points thought about and the game would necessarily revolve around the concept.
- Logic/Number/Vocabulary based.
- Game for young mothers.
- Entrepreneurship game/Trading and business games for young girls.
 - During the user study it was noticed that a lot of young girls were very interested by Trading, business and entrepreneurship based games. The games that involved buying and selling of stock and involving money were preferred by girls.
- Strategy, skill and chance-based detective games.
- History based learning games.
- Learning and experimenting with various professions.
- Construct your own house.
 - The concept was to have a two-stage game, with the 1st stage being where you earn the pieces and the 2nd stage would be to construct your own idea.
- Versions of existing game-themes with modifications to them.



Board/Base Themes

Alongwith the new themes for the game, there was also a thought given to changing the way the games are setup. These would further make the games different from the usual boards that are seen with games.

3D Board.

Inflatable board.

Assemble and setup game.

Shrinking or Expanding.

Random Play Environment.

- 3-Dimensional board/base.
A 3-dimensional board/base would put an interesting element into an otherwise flat board.
- Inflatable board/base.
An inflatable board/base adds drama to initial setup and can be deflated for packaging purposes.
- Assemble parts and setup the board/base.
This is also related to the setup of the game, it involves assembly of parts together. This might involve a specific way of arrangement or there can be uncertainty built-in by providing randomness.
- Shrinking or Expanding board/base.
The board/base can be made shrinking or expanding during the course of the game or after the game before repeat play. This will change the setup of the game and repeat play could be less predictable.
- Play Environment to be different each time.
This concept was taken directly from a pack of cards, something similar if added to a game, could provide a randomness to the game, with chances of repeat combinations very rare.



Game play Ideas

Gameplay would usually refer to how the game is played and what would be the medium by which the game moves ahead. Currently a die is rolled and the game moves on, some modifications were thought to make it more interesting.

Roll of the die.

Special Die.

Electronic Code die.

Spin - Wheel.

- Rolling the die.
Movements would be coordinated to either odd or even numbers rolling on the standard die.
- Custom-made die.
A custom-made die would have predetermined faces having arrows or objects related to the requirements of the elements of the game.
- Electronic die.
A look at the electronic die to substitute the existing six option standard die. An electronic die would be better for random numbers and more options.
- Spin-wheel.
The spin-wheel was looked at to see if another option could be used if there were more than six, but less than twelve spaces to be moved.



Chapter 4

Idea Development



Own the whole World

This game started by being a pirate game to satisfy an urge followed by every player to rule the world. The process began with the collection of information about the world, like a map, and also information of the various air, sea, and land routes.

The idea of the game was to make the players travel from one destination to another by using various internationally accepted land, air or sea routes. Once done with the travel, the players would arrive at a country and answer a few questions. If the person gets the answers right, he/she gets possession of the country card. The player with the maximum country cards in the end of the game wins.

But it was getting very difficult to make a board which was small and conveyed so much information about the world. It was getting over-informative and difficult to read. Moreover having moving pegs was also an issue.

So the board game was scrapped and the approach was rethought. Alternatives were brought in for a similar kind of game. The option that came up were just to keep the country cards and scrap the idea of the board. So information about the various countries and their required details was then prepared. The national flags, the country capital, currency and major languages made up the information to be provided initially. The cards were made and the information on them structured.

This done the cards were made and the game-play was discussed.

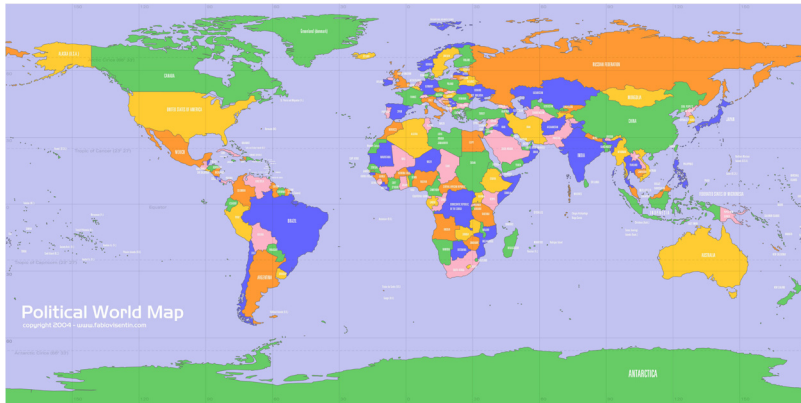

Fig. 4.1: Political Map of the World



Fig. 4.2: Major Air Routes of the world



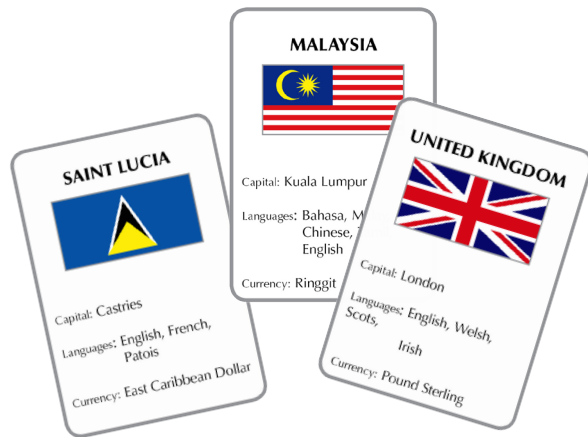

Fig. 4.3: A close look at country cards

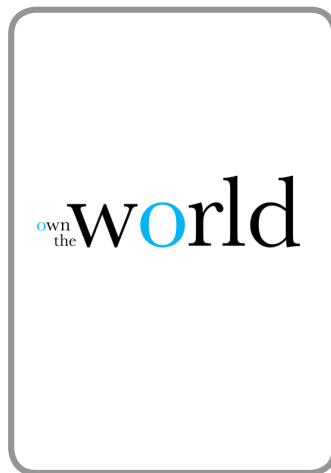

Fig. 4.4: The graphics behind the cards

Aim:

To win the maximum number of country cards by knowing the country information

How to play:

The dealer gives each player 10 cards to hold.
 The remaining cards are stacked in the centre.
 The player with the turn asks the question (eg. Which is the currency of Latvia?)
 The player next in turn gets the first shot at the answer, if he fails, the next and so on.
 If no one answers the card is rejected and placed aside.
 If the answer is right, the card is won by the person who answers correctly.
 The country card is owned by the winner and is kept with him. Now that card is not open to trade.
 The person who loses the card replenishes it from the stack.
 Once the stack is over, the opponents move over to the cards held in hand.
 The game ends when either one of the players exhausts the handheld cards.
 The player with the maximum country cards won, wins the game.

The next few pages give details of the countries and their cards. The game was appreciated by many as a knowledge based game which had the potential to introduce children as well as adults to the knowledge of country names, capitals, currency and languages.

The cards are as shown in the figure. They display the information which is available and the way the information has been structured. A visual graphic on the back reveal their orientation.

An expert version posing a higher level of difficulty, with a lot more information and new rules could be made as an evolution from the game. The new version could have rules which have been modified from the regular game to take it from being difficult to very difficult levels of intelligence.





The following is the information about the countries' cards that were made.



They have been arranged here in alphabetical order.



Once done, this was printed and the cards were played with to see if certain issues were resolved.



Fig. 4.5: country cards

Fig. 4.6: The printed cards



Fig. 4.7: country cards continued.

Formula 1

This game was designed purely with the Formula 1 enthusiast in mind. This game was designed to bring forward to the players the various aspects of the sport of Formula 1. The game was to feature the idea of interchangeability of tracks and achieve the most wins to seal the championship. The initial game design is presented here:

Aim:

To win the maximum number of races and have the maximum cash at the end.

Contents:

1 outer board, interchangeable tracks, car pegs, money, bank, die.

How to play:

Each player starts with an initial amount.

He has to allocate his resources to buy the team, car, wheels, driver, gas etc.

Each purchase carries points, these decide the validity and the qualifications.

Enter your car in the race, roll of die decides the movement.

One pit per race, two lap race.

First one to finish the race wins.

Winning of money and points after each race.

There are 6 tracks with varying difficulty levels and stages.

The players having the maximum points wins the game.

With these basic rules were formulated, the idea was to have an outer rectangular boundary with interchangeable internal tracks. Then there was a close study of all the various incidents that can change the course of any race. This would further contribute to how the game play would develop. These would be written on the track and the player would read them and act accordingly.

The initial brainstorming is shown in the images.

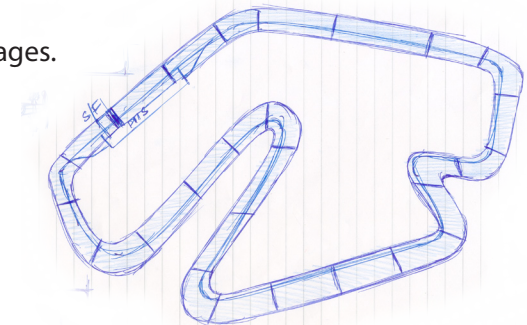

Formula 1 Game:-

Contents:- 1 Board, Interchangeable tracks, cars, wheels, drivers, money, ~~bank~~, die. (F1)

How to Play:-

- Each player starts with an initial amount.
- Player has to allocate his resources to buy, the car, the type of wheels, the driver and the team.
- How much gas to buy, how much to use and how much to preserve is a decision.
- Every purchase carries some points. The points decide the validity and qualification to race.
- Enter your car in the race!
- Play the die and decide how to move forward on the tracks.
- One pit per race, two lap race.
- First one to finish the race wins.
- Win points and money for winners.
- After each race drivers shuffle from a random pick from a black bag. Coloured dice
- Players have the chance of modifying their teams with their winning money, in between races.
- The player with the maximum number of points wins the game.
- There are 6 tracks with varying difficulty levels and varying stages of game play.

Uncertainty:-

- Introduce a qualifying track.
- Add concept of a life card.
- Different tracks, increasing level of difficulty.
- Also add live repair card, wet tyres card, spare & extra fuel to be added.
- Answer F1 trivia questions, just move ahead.
- Collect flag with answering strategic questions, if you have a flag only then you finish the race.



- What happens during a race:
- Stalled at the start, go back, start from pits.
 - First corner collision, start from the pits after one turn for repairs.
 - Slide on corner, loose one place.
 - Went off-track loose two places.
 - Crashed, raceover
 - engine blowout, raceover
 - starts raining, not more than 3 allowed on dice.
 - Turbo boost, double the number on the die.
 - flat tyre, limp to pits, play alternate turns.
 - you just passed the driver ahead, he misses.
 - you block the driver behind you, he doesn't overtake you for next 2 turns.

Fig. 4.8: Race Scenarios

Most of the effort in making the game exciting to play was involved in capturing the essence of the sport in the board game. The races were studied to see what are the interesting activities that occur during the race. These were listed and the board was designed in a way to reflect the same.

Also shown herewith is the basic structure of how the different tracks fit into the board.

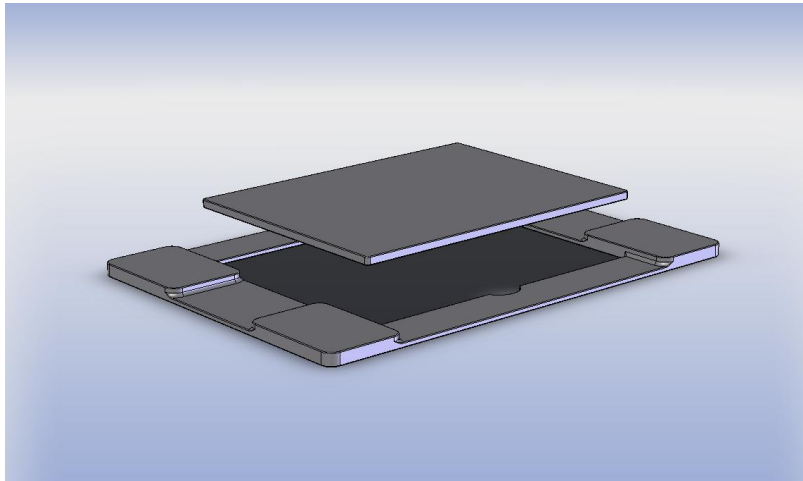

Fig. 4.9: This is how the track fits into the outer rectangular frame.

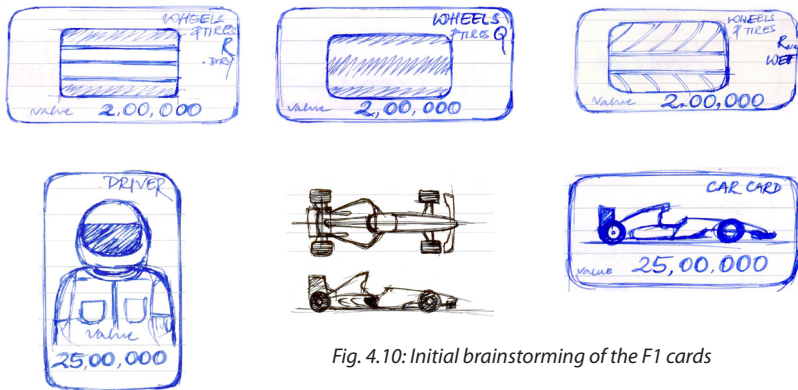

Fig. 4.10: Initial brainstorming of the F1 cards

What happens during a race

- Stalled at the first corner, go back start from the pits.
- First turn collision, start from the pits, miss a turn.
- Slide on corner lose one place.
- Went off track, lose two places.
- Crashed, raceover
- Engine blowout, raceover
- Flat tire, limp to the pits, play alternate turns.
- You just passed the driver ahead, he misses a turn.
- You block the driver behind, he doesn't overtake you.

A certain amount of uncertainty was later added into the game. Uncertainty was introduced keeping in mind the scenarios that might arise during the course of the game. A few are given.

- Introduce a qualifying track.
- Add concept of a life card.
- Different tracks, increasing level of difficulty.
- Answer F1 trivia questions and answer them to move ahead faster.

Once the basic rules were thought about, the initial cards were made and the tracks were thought of with the different scenarios that occur within the race. These cards were further fine-tuned and the final versions of these are shown on the next page.



Fig. 4.11: Initial Design of the F1 cards

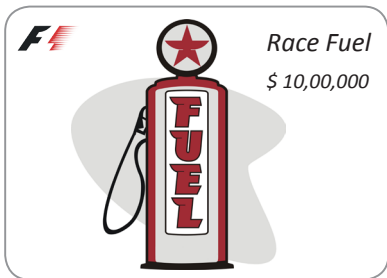

The initial cards were very bold, the design was modified with some better graphics to be more readable.

Since the costing was being worked out simultaneously, there were requisite changes made to the costs that were printed on the cards.

The final cards are displayed in the images, the finalized F1 game cards were later printed and cut as per their requirements. Though not displayed here there were different cards of different colours made for each of the teams. Shown here is the set of cards for a single team.

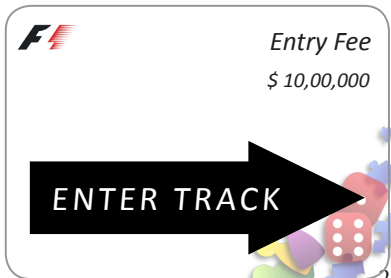

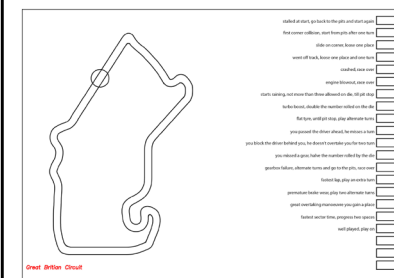

Fig. 4.14: The various tracks designed for the F1 game.



Knockout

Unpredictable is what every game should be and it should also have that element of surprise that keeps the players on their toes perpetually. The shrinking game was designed with that same intention in mind. It is purely a luck based game which shrinks in size after one game is done. Ideally this makes repeat-play more interesting and unpredictable.

Moreover to keep the unpredictable nature going, the 36 pieces of the game can be arranged in the manner as the player wishes. This reduces the chances of the same situation arising again, and thus it increases the chances of repeat play. The details of the game are as given below.

Aim:

To advance to the next round by winning, the last to reach the finishing line gets eliminated.

How to play:

Arrange the inter-locking pieces to form a square.

The players have to roll the die and finish a single journey from start to finish.

The player who finishes last get eliminated.

After this remove one piece from each side and repeat the journey from start to finish.

Repeat the same process until there is a winner.

Various designs were tried to see which one suits a transit environment the best. An easy removable design with closer fitting tolerances was preferred. There were 36 game pieces with 4 corner pieces or home pieces.

Fastluck

Components: 36+4 (corner pieces) = 40 interlocking pieces.
4 pawns, one dice.

Highlights:- Modular interlocking pieces, shrinking Board concept.

Gameplay:- 3+ players game. (max 5 players)

- Roll of the die, advance.
- You also have road markers tell you by luck whether you move forward or step back.
- One full round until the start again qualifies, first come first qualification.
- Every time the last person gets eliminated or knocked out.
- Disassemble one brick from each of the 4 sides and repeat play til another one gets eliminated.
- The person who remains last wins the game.



- Shrinking Board Game
- Modular Interlocking
- Random turns
- Every turn the player in last position has to remove one piece from each side.
- Add uncertainty
- Random play
- Parallel lines
- The lucky move ahead a place.
- The unlucky move back two places.
- Lucky play goes.
- Unlucky move play next turn.

Uncertainty:-

- We lucky, move a place ahead / play one more turn.
- We unlucky, move a place back / miss our turn of die.



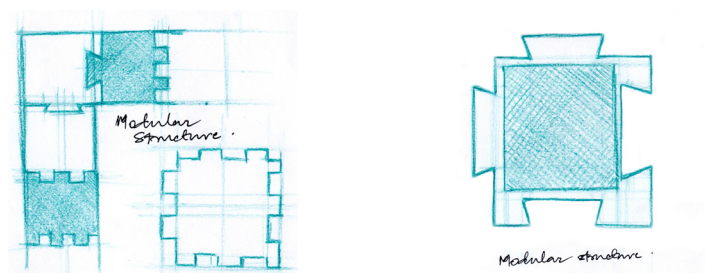

Fig. 4.15: Initial brainstorming for the modular game pieces

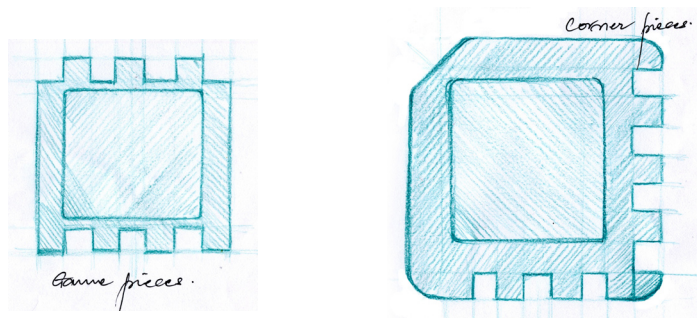

Fig. 4.16: The finalized game pieces.

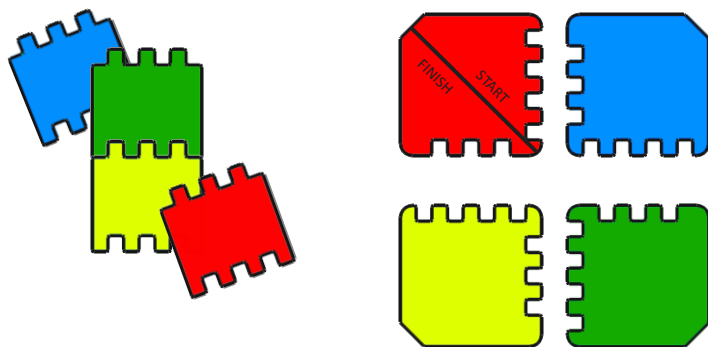

Fig. 4.17: Colour versions

The images on the left show the initial explorations about the shape of the parts. The idea was to have a modular structure. These inter-linking pieces would be like a simple jigsaw which fits into each other and results in the game board.

Various colours were tried out to make the game pieces more vibrant. An initial mock-up was made to check up on issues faced during play. The mock-up gave ideas about the addition of a few features.

The images on this page give all the details.



Fig. 4.18: Initial Mockup for Knockout

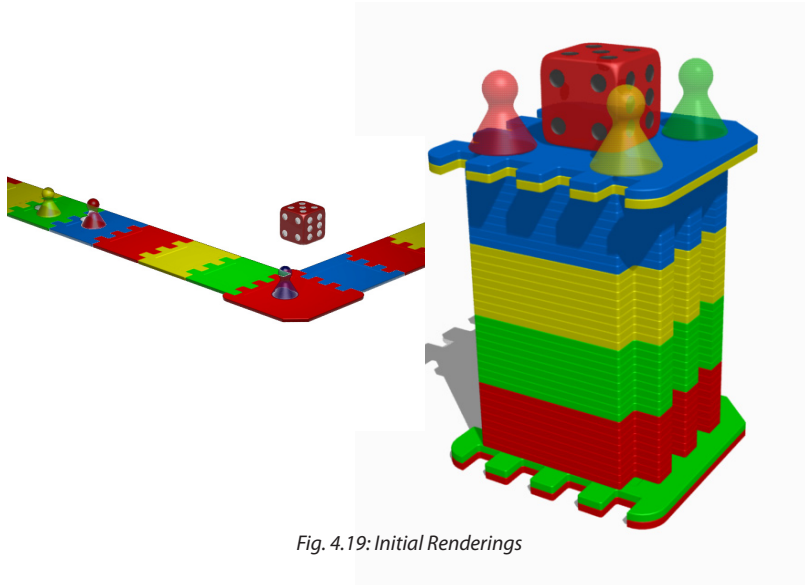

Fig. 4.19: Initial Renderings

Certain changes were made to the initial game after making the model, to make it more interesting and fun to play. A few pieces were marked with increments of 2 and 1 and some pieces were marked with decrements of 2 and 1. As usual their position would be decided by the players arranging the pieces together, this led to a certain element of chance into the picture.

Another modification was the addition of the coincidence rule. The rule added was that if a player comes from behind you to the exact same spot that you are on, you get demoted to the nearest home (corner) that you have just passed. This rule added to the amount of unpredictable nature already found in the game.

Moreover if required, a rule could also be made restricting which piece has to be removed everytime. Eg. The first piece after every corner piece (home).

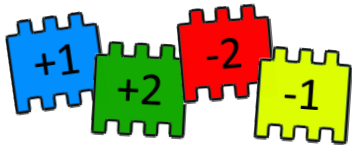

Fig. 4.20: Uncertainty pieces

Since the game was made completely out of a modular structure arranging the parts for packaging needs was too easy. It even became very compact and easily organized.

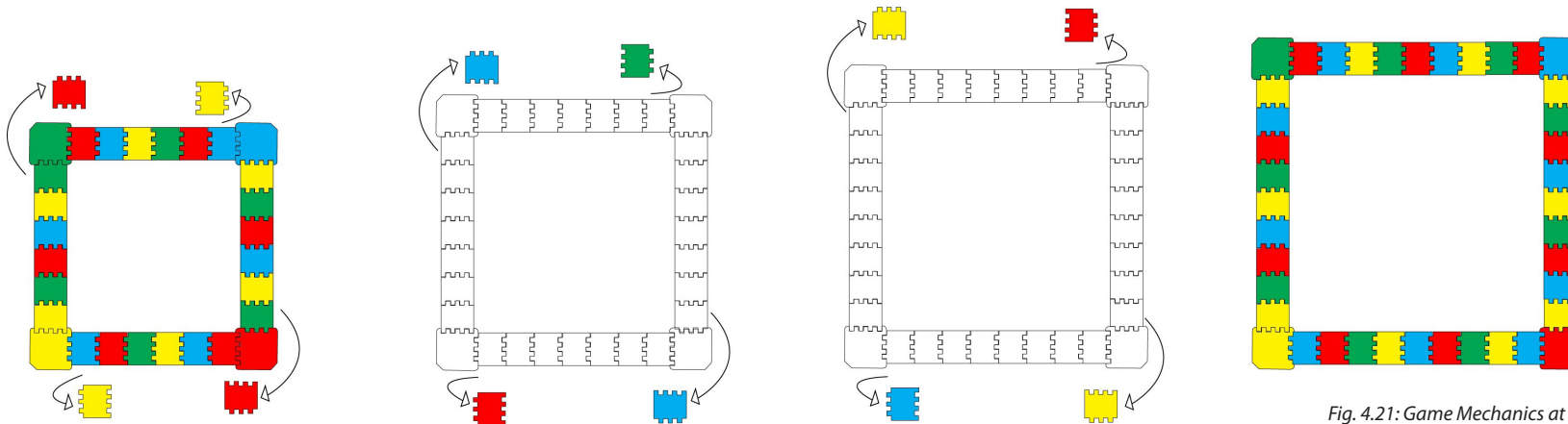

Fig. 4.21: Game Mechanics at a glance



Features:- Simple and easy to learn.

- Transparent acrylic makes it easier to play a 3D game without any blindspots.
- Easy to assemble pieces and mounts on base to play.

Contents:- 3 persons/pegs, one custom die

Game play:-

- Fix your peg at the bottom of your selected side.
- Roll the direction die, proceed in the direction rolled on the dice.
- You can move as many paces in the direction rolled on the dice.
- You are also allowed to move in your opponents area.
- The first person to reach the top wins.
- The game gets tougher as you get higher, there are 4 levels.

Vertical Limit

This game was developed with an urge to break the normal flat board-game convention and have something starkly different. An inspiration was taken from rock-climbing and the same style was later on adapted to make the game.

The indoor rock-climbing event though is a fast paced game where the winner takes all. The same theme was extended here, by keeping the details to the minimum and thus inducing the players to be the first to finish. A grid was designed and each player would thrust their peg into the holes to mark their position.

A folding transparent game was thought about so that it allowed the opponent to see clearly the players movements. A custom die having arrows was designed to take care of the proceedings. The game was made in two or three player versions.

Aim:

Be the first person to reach the top and seal the fate of your opponents.

How to play:

Place your peg in any of the holes in the bottom line.

Roll the special Die to play.

The arrowhead specifies the direction of motion.

You can move as many places as you want in the specified direction.

Dot, means no movements in any direction.

Restrictions:

You are restricted from using your opponents panel.

Images on the right show the initial brain-storming.



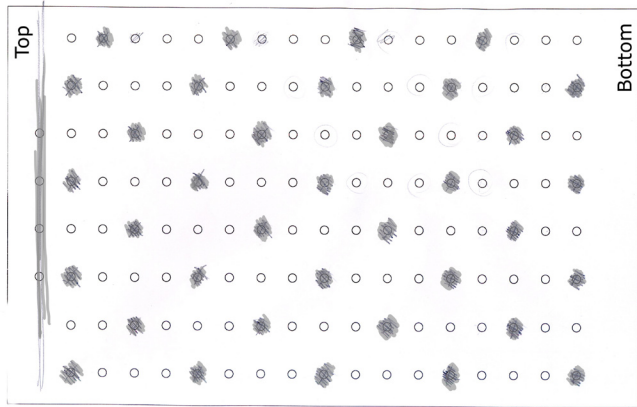

Fig. 4.22: Initial game board

After the first play, major modifications needed to be done to the board and the holes provided. A CAD print was worked upon after playing successively. Care was taken to see that the number of holes in any one direction do not exceed three.

The diameter of the holes was also decreased so that the pins do not fall off during a travel situation. Moreover to counter act the forces, of regularly moving the pins and placing them at new locations, a base was developed.

The panels are fixed into the base, so that the base compensates for the movement.

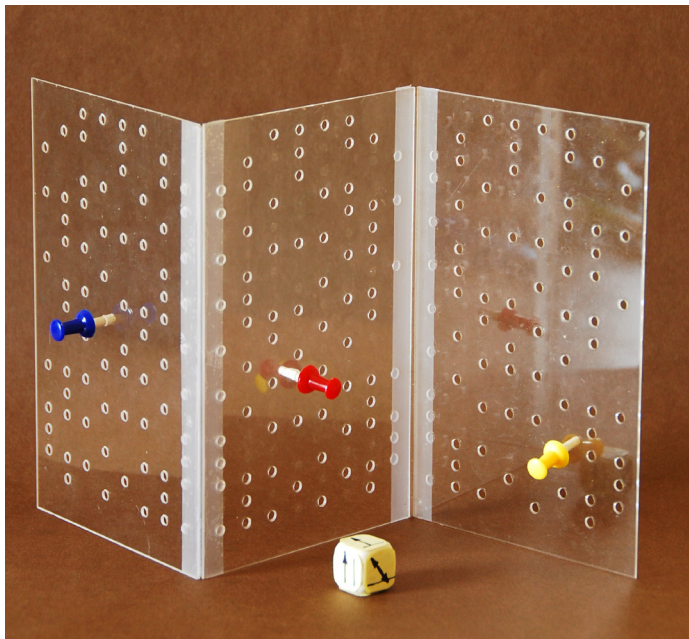

Fig. 4.23: Initial board Mockup

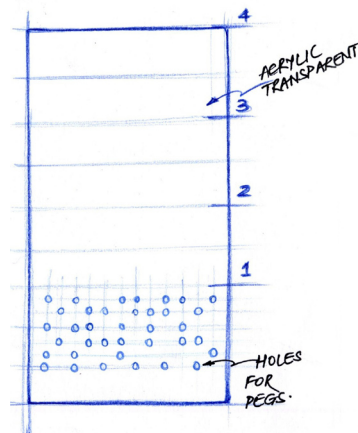

Fig. 4.24: Initial idea development

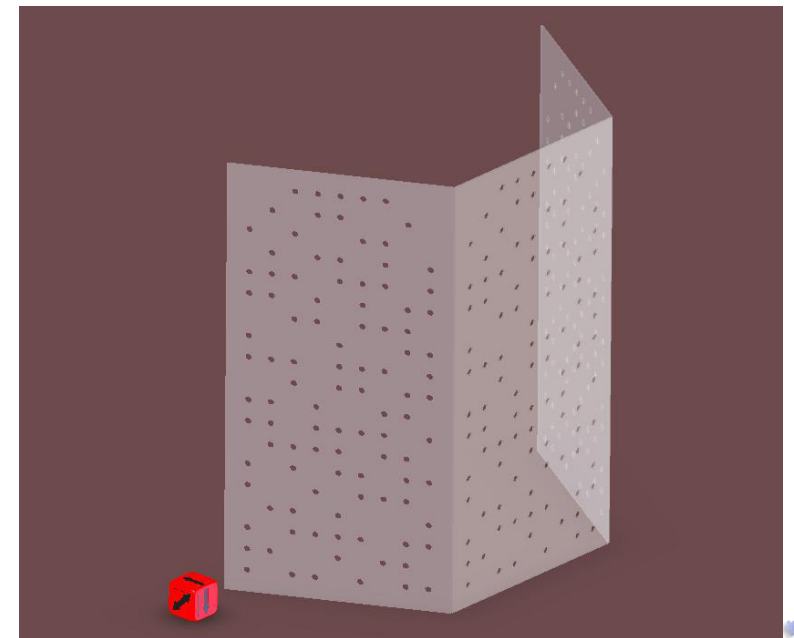

Fig. 4.25: Initial Product rendering



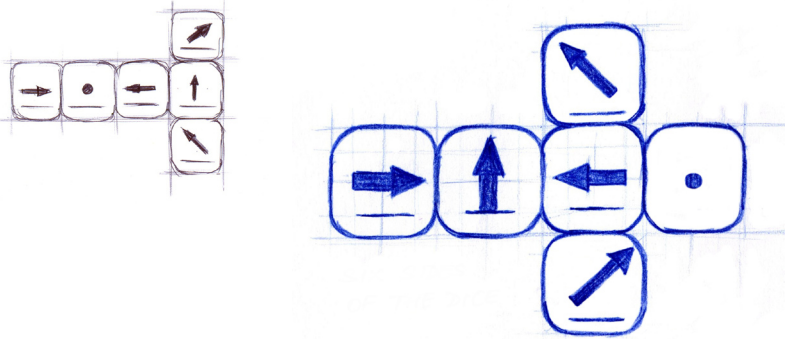

Fig. 4.26: Final Six sides of the special die

The faces of the special die were worked upon and depending on the game-play various iterations were done. Finally one was decided upon. The final board was decided and finalized in CAD.

Alongwith the details the packaging was given a thought and the hinges for the players panels was thought about.

This base would be the part of the packaging and would be of a harder material so as to protect the otherwise fragile panels. The base was also designed to hold the panels firmly during a scenario involving movement.

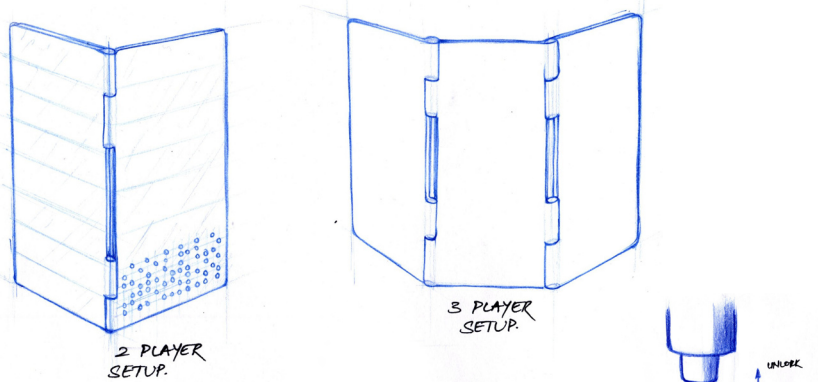

Fig. 4.27: two player and three player setup in the game of knockout

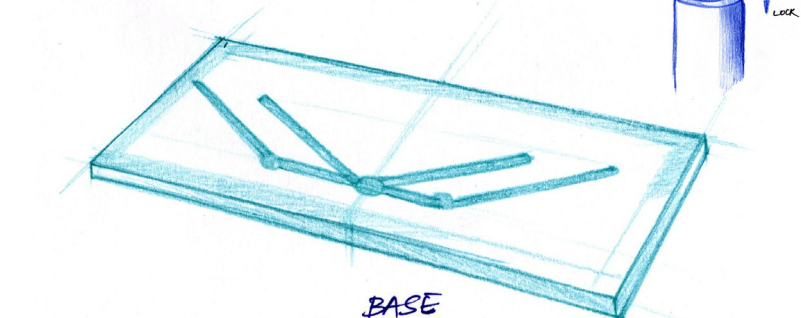

Fig. 4.28: The base which also doubles-up for carrying. The slots are for 2 player and 3 player setups

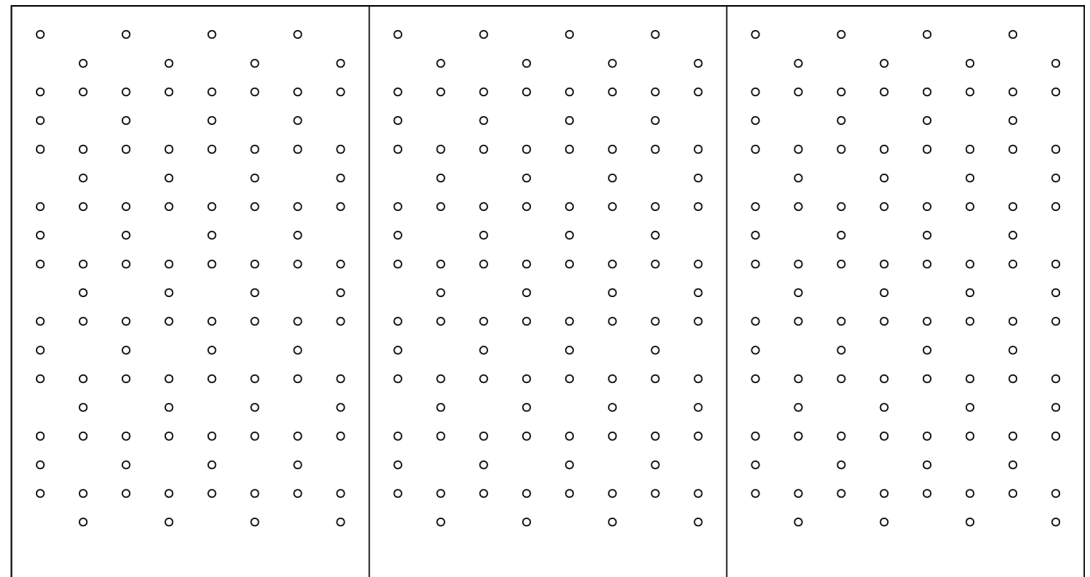

Fig. 4.29: The finalized layout of the holes.



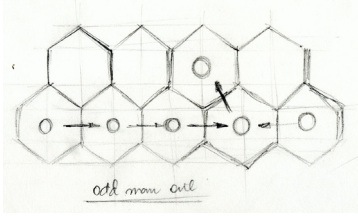

Fig. 4.30: Initial game-play idea

Hexagonal Game

This game was an outcome of an urge to break the boundaries of doing the regular. So an attempt was made to replace the regular with something different. The hexagon shaped markings on the board allow for sideward movement as well as movement along the diagonal too.

The rolling of the die as the chance element remains, but its results get grouped into odd and even. The player gets an opportunity to move ahead only if he rolls an odd number. The movement of the pegs is as shown in the figure.

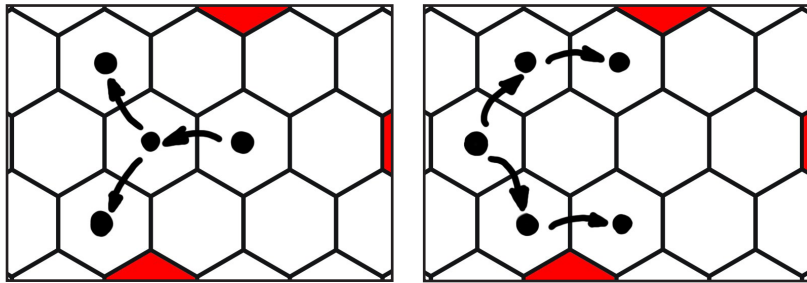

Fig. 4.31: game play rules and movement of pegs along the hexagonal grid when odd numbers are rolled on the die

Aim:

To get your pegs to the other end by rolling as many odd values as possible and also to fight your opponent and preventing him from winning.

How to play:

Place 4 pegs in any of the hexagons, along the first row on your side of the board.

Roll the die to play.

If an odd value appears (1,3,5) move even numbers to the side and a diagonal element ahead or a diagonal element ahead and even to the side.

If an even value appears (2,4,6) move only those number of times to the side.

The red blocks are obstructions, you cannot cross them or jump over them.

You can fight your opponent by bumping into him or pushing his peg in to the red areas.

The first person to fight his opponent or get all his 4 pegs to the other side wins.

Restrictions:

Beware of the red areas, they are dangerous.

Your are not allowed to jump over your opponent or over the red areas, if you are stuck, you forfeit your turn.

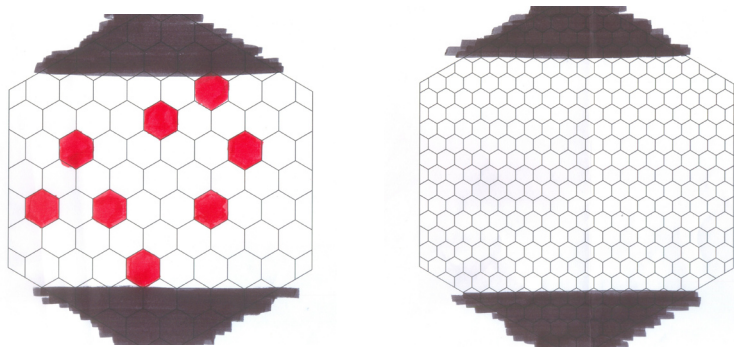

Fig. 4.32: Initial Board sketches



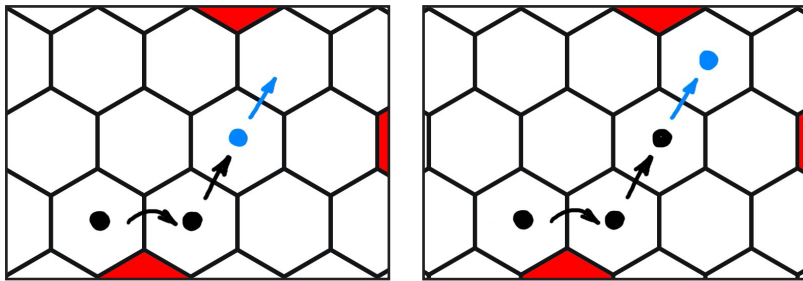

Fig. 4.33: Game play graphic for understanding the 'Bumping and Pushing'

Further more, the fighting with the opponent was not always necessary to kill him. Here the way is to push him behind or to the sides. The method to destroy the opponent's pegs is to push them into the red areas. The bumping and pushing is as shown in the figure.

The place of the blue peg, which is the opponents peg, is shown displaced due to the movement of the black peg. If pushed into a red block the blue peg is out of the game.

A further extension to the game was thought about in the graphics and the packaging. A foldable board which opens up to represent two enemies in a battle scenario. And the hexagonal grid would resemble a completely dried and cracked battlefield. The red dots could be replaced by traps and death traps in the battlefield.

The graphics for the final game idea, still need completion.

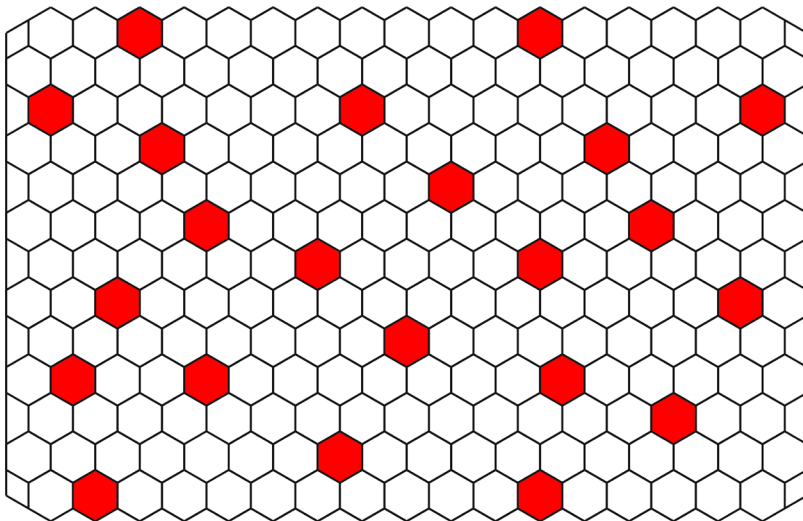

Fig. 4.34: Board game with red dots for restricted areas. These could be replaced by traps.

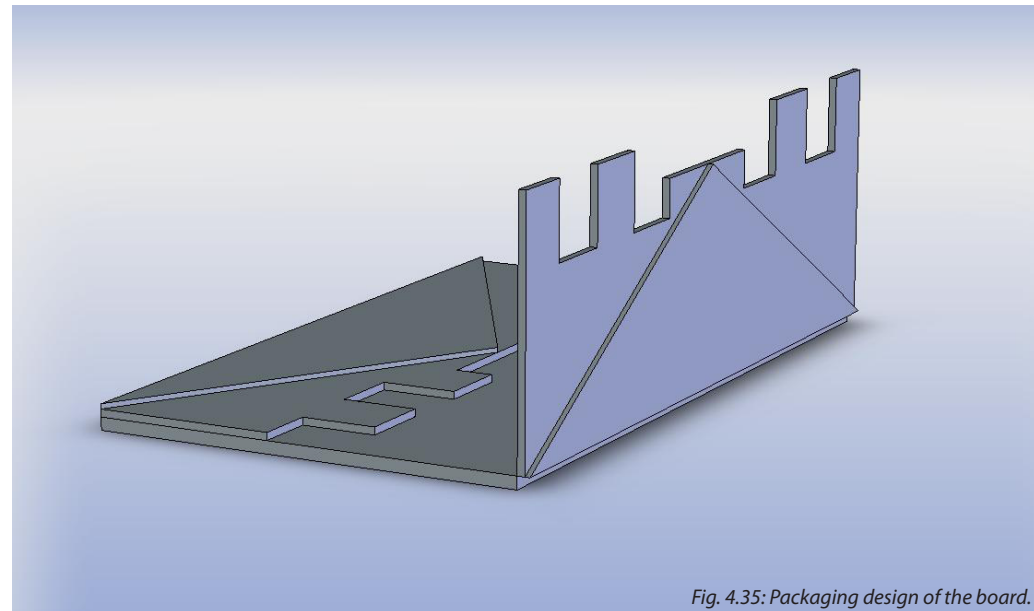

Fig. 4.35: Packaging design of the board.



Very Initial Game Themes



Hunt the Terrorists

Looking at the present scenario and the attacks on the city, a game was devised upon to hunt the terrorists. The idea was to have a game which is a three or more players game, where one player is the terrorist and the other two are of the special squad. The initial game details are as given below:

Aim:

The police track down the terrorists before they can plant a bomb in six places in the city from 12 to 15 pre-alerted risked locations. (police officers might include ATS, Marcos, RAF)

How to play:

One turn per person, no roll of die, terrorists start first.
 Roads and streets are marked and numbered.
 Terrorists write down their moves on a pad, it is not revealed.
 The terrorists reveal themselves once every 4 turns.
 Officers use their own vehicles to pursue the terrorists or travel by foot.
 Terrorists may use the train, the bus or the taxis until their token coupons last.
 They have to make themselves visible if they plan to boost a police vehicle.
 Each officer gets two chances to diffuse a bomb, by answering a specific question.
 He gets an award for his bravery.
 Terrorists lose one ticket for every bomb found.
 Terrorists win if they get-off all six bombs, the officers win if they catch the terrorists.
 Officers also get backup.

Hunt the Terrorists:-

Contents: 1 Board, Map of ^{Some Place} South Bombay, custom-made, Police pegs, terrorist pegs, Bomb pegs.

Aim: Police track down the terrorists before they can plant a bomb in six places in the city from 12 to 15 pre-alerted risked locations.

- Police officers include ATS agents, MARCOS, BLACKCAT, RAF.

Gameplay:-

- One turn per person, no roll of die, Terrorists start first.
- Roads and streets are marked and numbered
- Terrorist write down their moves on a pad, it is not revealed, Terrorists reveal themselves once every 4th turn.
- Officers use their own vehicles to pursue the terrorists or travel by foot.
- Terrorists may use the train, the bus or the taxis until their token coupons last. They have to make themselves visible if they plan to Boost a police vehicle.
- Each officer gets two chances to diffuse a planted bomb. He gets an award for bravery.
- Terrorists loose one ticket, per bomb found.
- Terrorists win if they get off 6 bombs. the officers win if the catch the terrorists.
- Officers get backup.



The game was a version based on the popular Scotland Yard game. A lot of changes were done to the gameplay of the original game. Most of the rules were devised so as to give the terrorists a hard time to find their way around the game.

Some initial development was done to see if the city-map could be gotten right. Since it was becoming very difficult to have a very small map which is clearly visible and readable the idea took a back seat in the list of concepts.

Fig. 5.1: City map



Environment Game

Another game theme which seemed to emerge from what we see and interact with everyday, the environment around us. We seem to be forgetting about the environment and due to our negligence, destroying it.

Even though subjects like EVS (Environment and Value Sciences) are part of the school curriculum right from the 3rd grade onwards to the 10th grade, its applications are found to be very limited. Probably one of the reasons would be the restricted understanding due to lack of opportunities to test the knowledge in real life situations.

The idea was to develop a game which could be played during a routine job or tiring activity so as to make it more useful and gain knowledge while at it. Not only that, if the game could cater to a wider age group it could be easier to inform people out of school what they missed.

With this in mind, ideation began on the game play. The concept of green points emerged and was then developed further. The idea was to award green points for every action taken by the player to save the environment. And deduct green points for every action to harm the environment.

To see what was taught to the students, the books from the school curriculum were purchased and read through to see the contents. The contents were reflected upon to see if a certain game play was possible with these in mind. A lot of situations were found and listed, and their repercussions were studied. A few important ones were clubbed together to form groups and look at scenarios.

Many approaches were tried and worked upon, one amongst them was the design of a 3d gameboard, which could be inflatable or could be assembled to protrude out of the flat board/base.

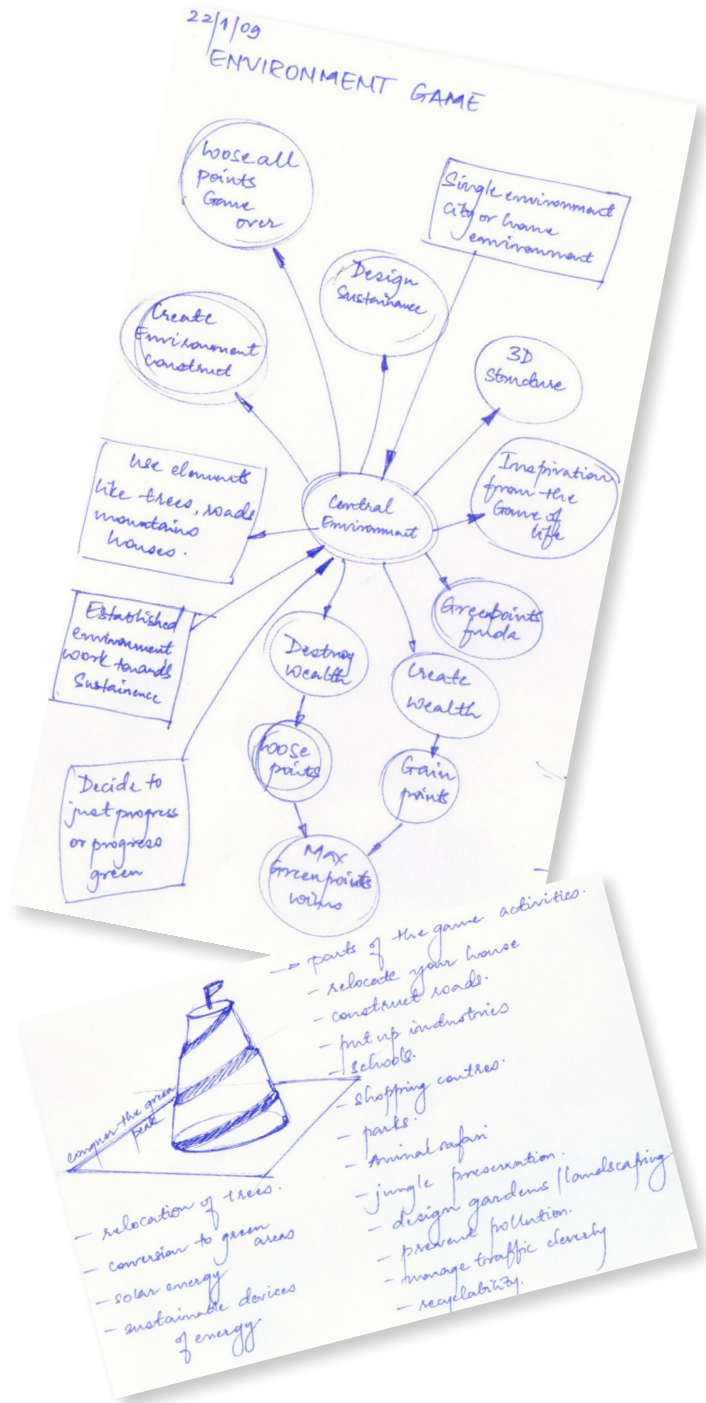

- Build an environment from details
 - If you build a better environment you win points.
 - If you destroy environment you lose points.
- Build a factory
 - Set it up to handle environment hazards.
 - Decide which factory to put up.
- 3D board game inflatable.
- Add abstract elements.
- provide surplus.
- counters like stepometers or thumb counters.

The versions designed were of the constructive and sustaining types. The constructive game involved either building a completely new environment from scratch, or the betterment of a failing ecological system. This would involve knowledge of sustainable systems and a look at the systems which would cause the environment to deteriorate.

The sustaining type of game would be all about sustaining the existing resources which would be used to the fullest without exhaustion. Similar to the current situation faced by the world this would allow the player to set strategies such that alternate resources would be looked into and green points could be earned.

The concept of green points could not be developed further and the situations were too difficult to rate and value. Rather the concept of the 3d board game during travel also seemed objectionable with visibility being a primary criteria. Moreover the school curriculum was too vast to cover in such a short period of time.

All constraints coming together became very difficult to put together and devise a gameplay. Also the amount of information to be circulated was too large to have conventional hardware, so step-o-meter displays were looked at as an option.

Electronic displays and random number coding upto 999 combinations was explored with an electronic die. But since the game play couldn't be decided upon the development took a backseat.



Chapter 6

Evaluation



	Easy to learn	Easy to play	Small packaging	Compensate travel motion	Minimum hardware	Onlooker attention	Durable	Unpredictable	TOTAL
Formula 1	2	7	6	7	5	7	6	7	47
Own the World	4	7	9	9	9	6	8	9	61
Knockout	9	9	9	6	5	9	5	9	61
Vertical Limit	9	9	8	7	8	6	7	9	63
Hexagonal Game	8	8	7	7	7	7	8	8	60

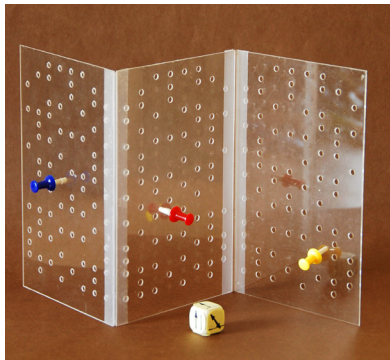

Fig. 6.1: Vertical Limit



Fig. 6.2: Own the World

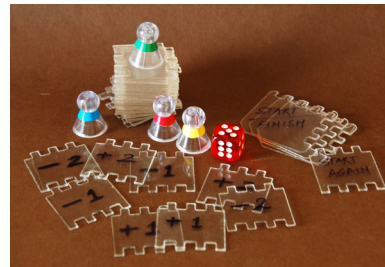

Fig. 6.3: Knockout

From the evaluation of all the games on the various criteria, it was decided that the games with the maximum total would be selected.

So it was decided to make three final products. Vertical Limit, Own the World and Knockout. If time permits then a fourth game, Hexagonal game, would be made.



Chapter 7

Final Products



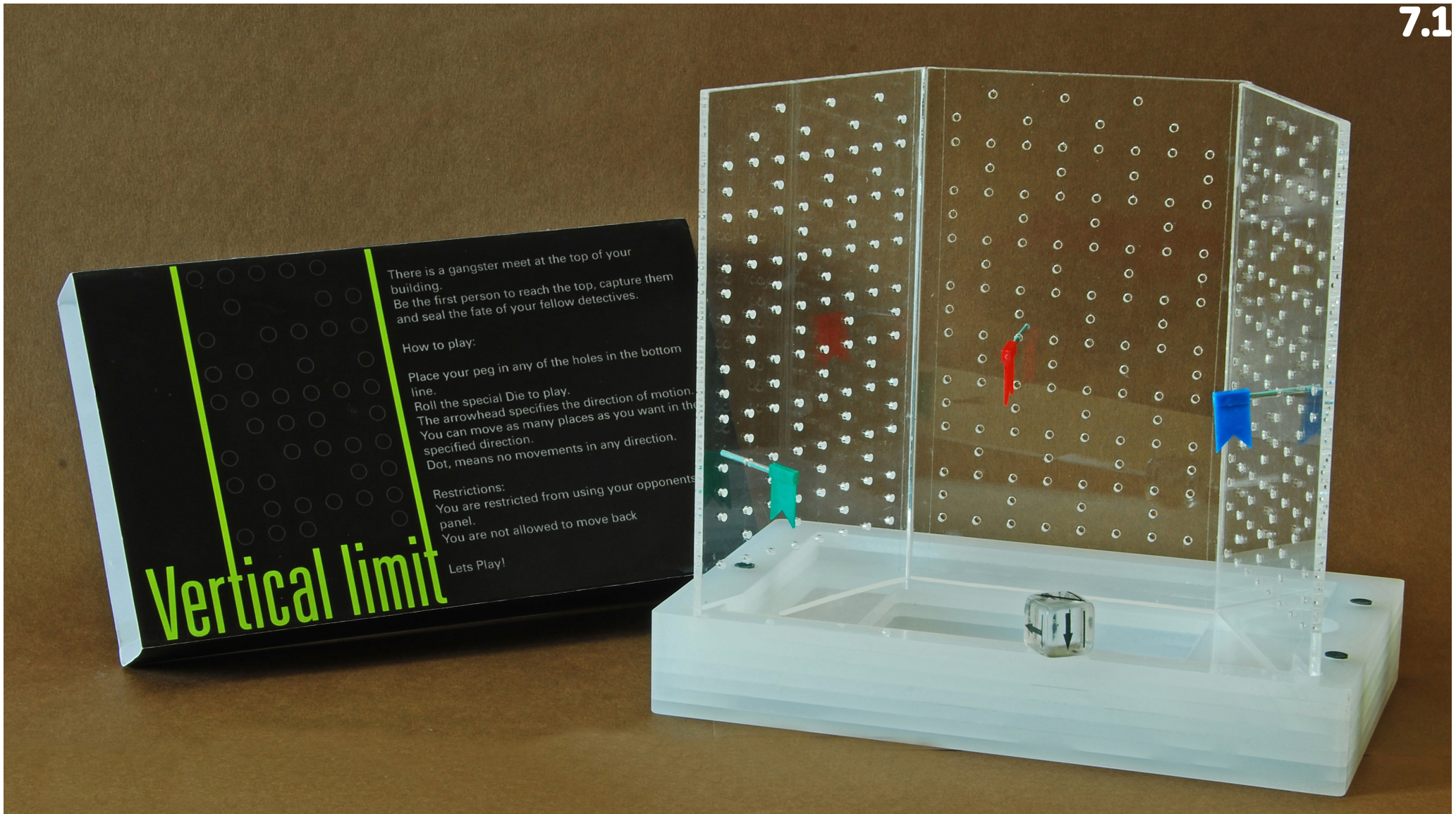

The first game made was Vertical Limit. A theme of having gangsters was put in the game just so that it interested children.

The entire game was made from transparent acrylic. A strong base was provided so that the game remained stable during travel scenarios.

The packaging of the game was designed to be easy to use. The rules as well as the theme of the game were printed directly on the packaging of the game.

The final game is as shown in the visual.





The second game which developed was Knockout. A theme of having the entire game shrink during playing the game was introduced.

The game elements were made from coloured acrylic which were interconnecting to form a customize-able larger structure.

The magnets incorporated made the game easy to pack irrespective of the hardware featured in the game. The rules as well as the theme of the game were printed directly on the packaging of the game.

The final game is as shown in the visual.





The third game developed was Own the world. It was a card game and was developed in two difficulty levels. The packaging was to be sleek and easy to carry with being effective to hold all cards.

The final products are as shown.



References



http://www.fabiovisentin.com/world_map/free_world_map.asp

date visited: feb 2009

<http://www.hipkiss.org/cgi-bin/maps.pl?book=London%20Geographical%20Institute%20-%20The%20Peoples%20Atlas>

date visited: feb 2009

<http://www.mapsofworld.com/major-holiday-cruise.htm>

date visited: mar 2009

<http://www.flags.net/fullindex.htm>

date visited: mar 2009

<http://www.formula1.com/>

date visited: jan 2009

Class notes from Game design elective by Prof. Athvankar

