

Training at Blow Plast Ergonomics Limited, Nagpur

June 2003
Darshan Rathod
Krishna Kumar R.

IDC, IIT Bombay

Blow Plast Ergonomics Limited, Nagpur

Blow Plast Ergonomics Limited (BPEL), Nagpur is a division of D. G Piramal Group of Companies. BEPL has primary interests in SYSTEMS FURNITURE. Operations commenced in the year 1992, under Technical collaboration Agreement with Element International Partnership, Australia.

PPD

MIS

DnD

Accounts

- Introduction to Modular Furniture and existing products
- Understanding the Manufacturing process
- Organization
- Preliminary exercises in product form appreciation
- Analysis of an existing mechanism for product application

Project

- Design of a Charpoy

International Products

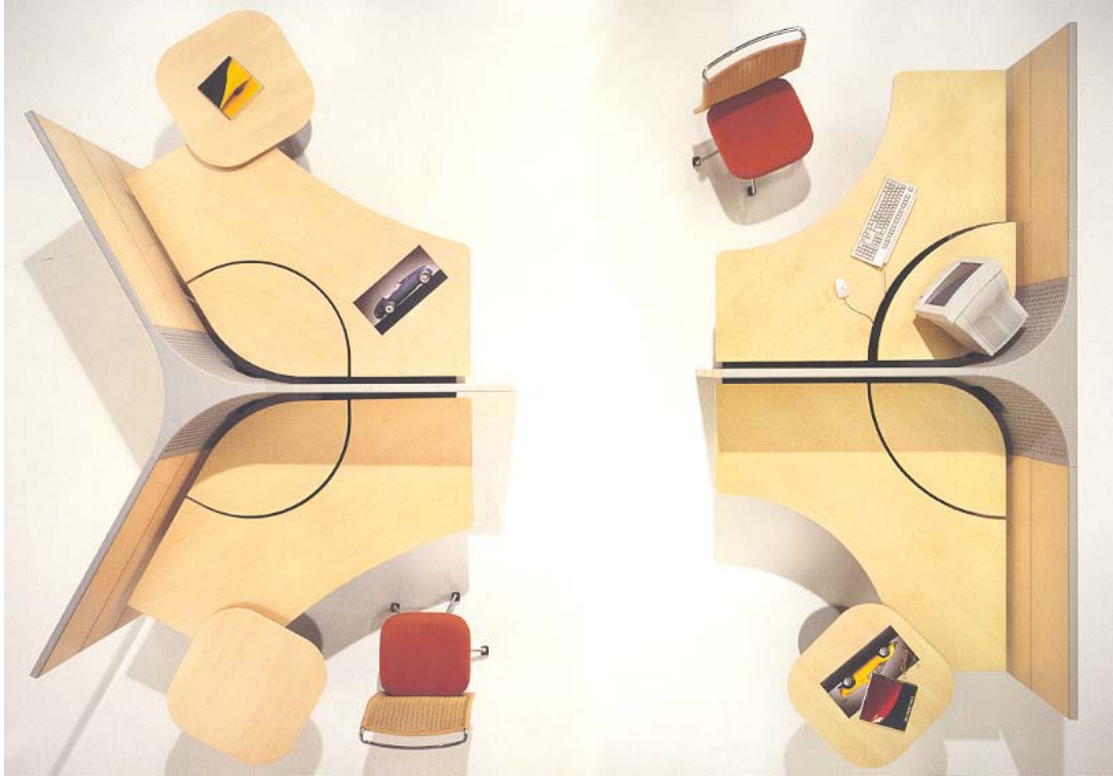

West

- New Materials and technologies
- Innovation
- Conceptual Design
- Quality control

International Products



East

- Imitation
- Mass Manufacturing at low costs

Blow Plast Products



Limitations and Solutions

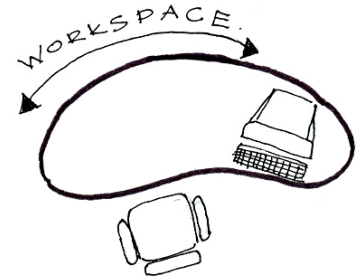
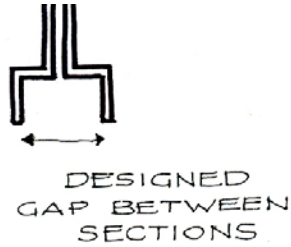
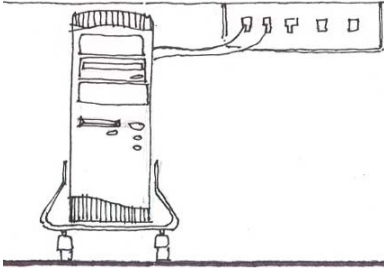
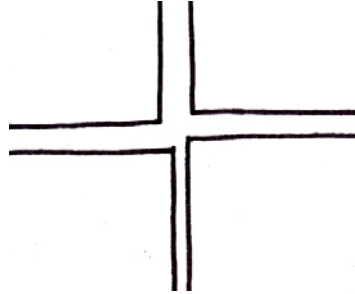
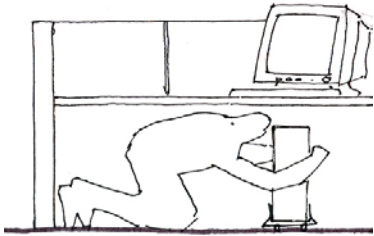

Hardware and Finishes



Panel Conversion Plant

Particle Board
MDF

- Beam Saw
- Panel Cutter
- Molder
- Glue Application
- Hot Press
- Post forming
- Router
- Edge Banding
- Curved Edge Banding
- Sander
- Edge Sander
- Painting

Beam Saw

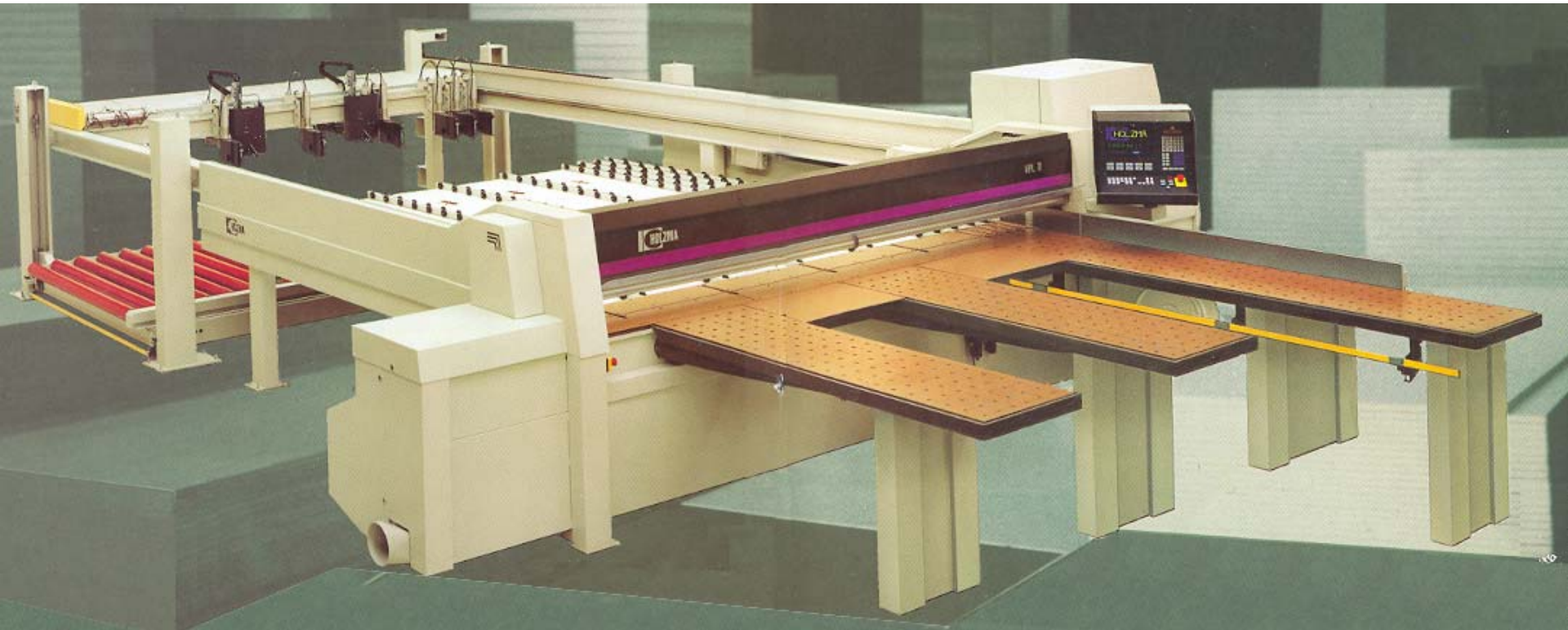

Panel Cutter



Molder



Router



Glue Application



Hot Press



Post forming

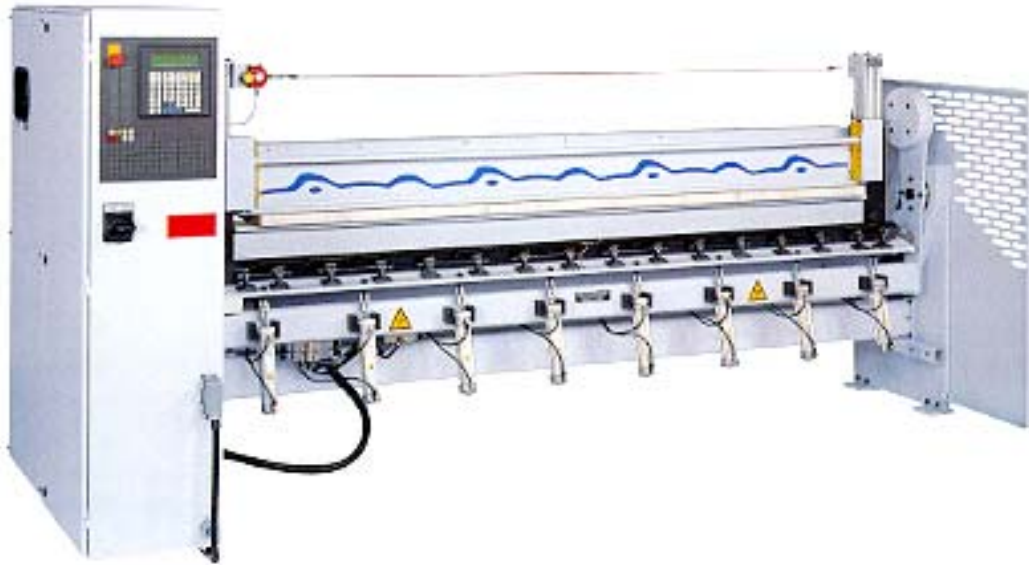

Edge Banding

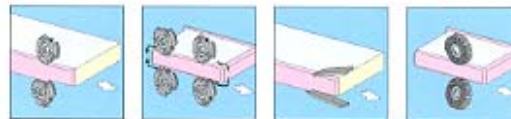
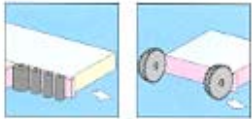

Curved Edge Banding



Vendors

Materials

VIP Industries Ltd.
Sheet metal working

Mechmet
Sheet Metal working

Avon
Work in Pipes

TouchWood
Membrane Pressing

Product form appreciation

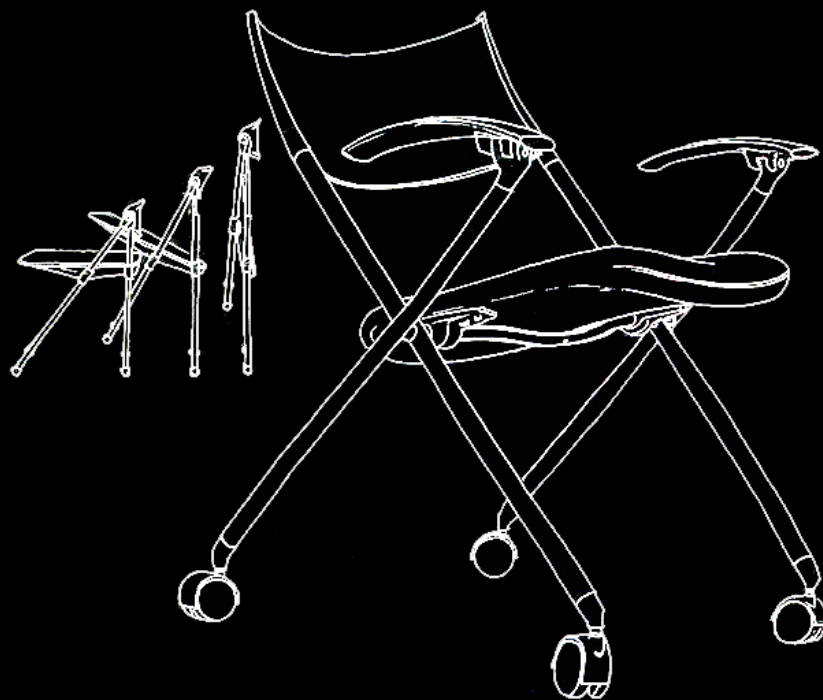
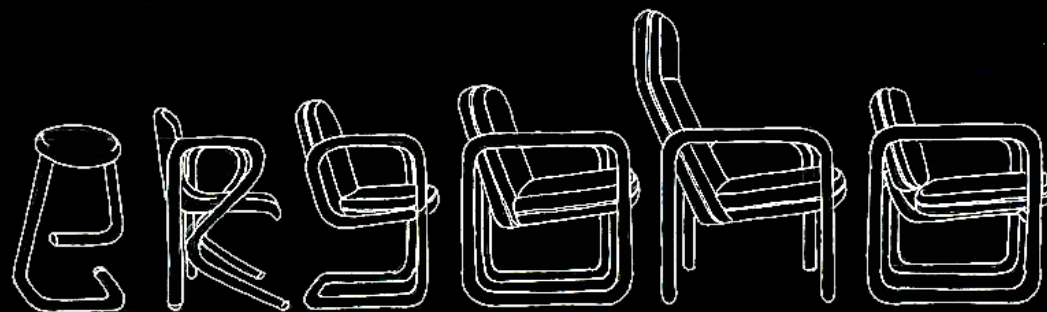

Product form appreciation



SLEEK

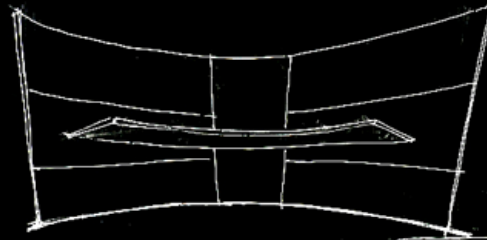

PLANES
PLANES

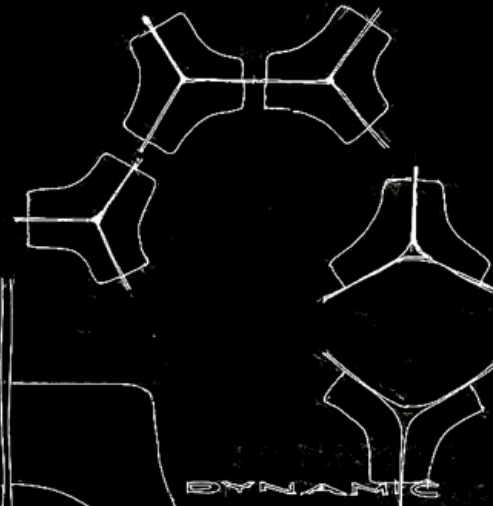

DYNAMIC

FLIGHT
MOVEMENT
ELEGANCE

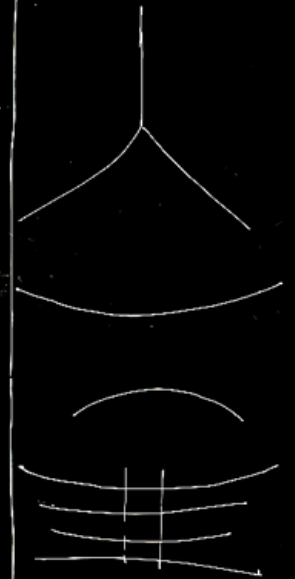

LINES
LINES

Analysis of Mechanism

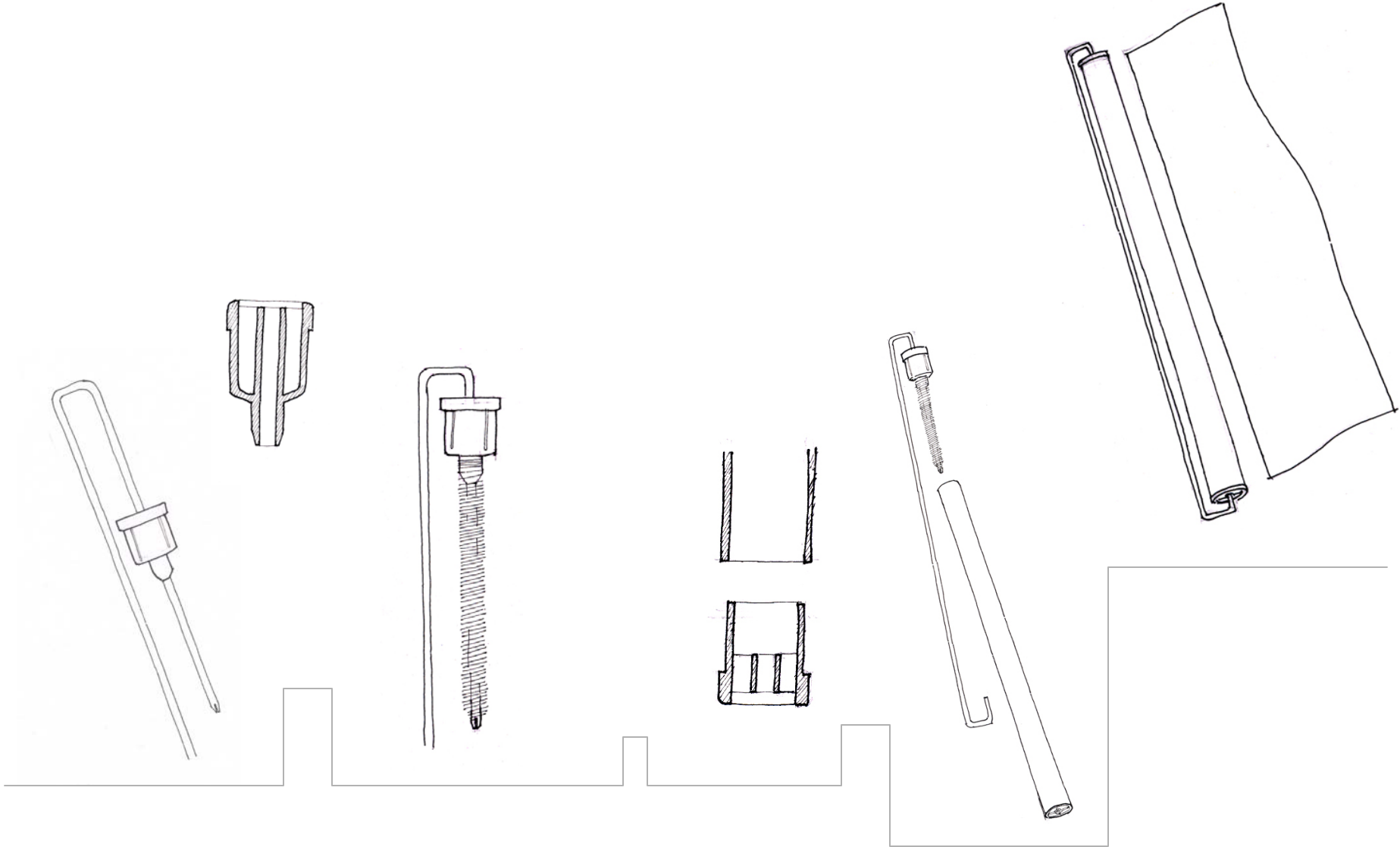

Design of a Charpoy

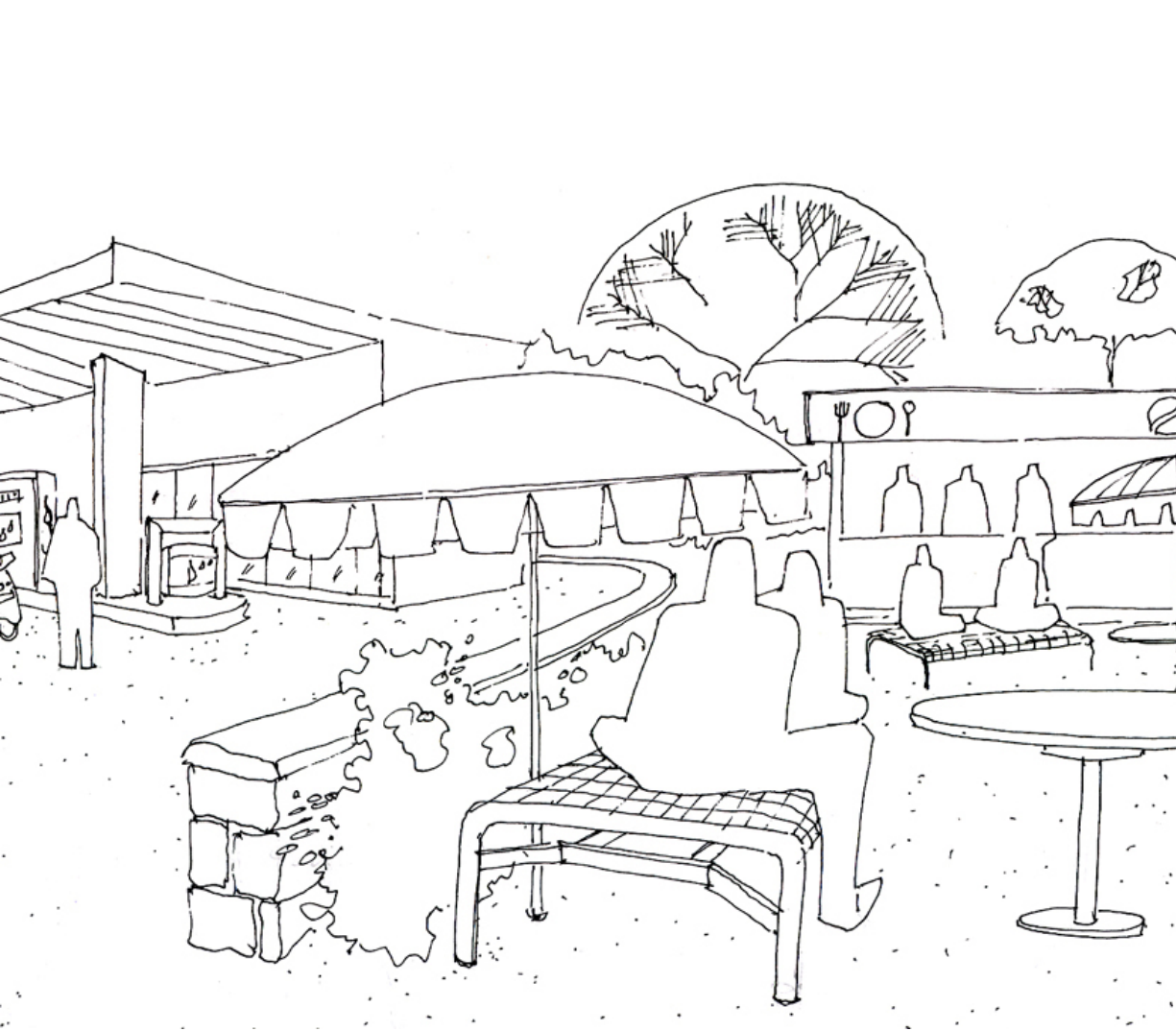

Design Brief

- Design of a charpoy using Newar and cotton rope

Study of existing Charpoy

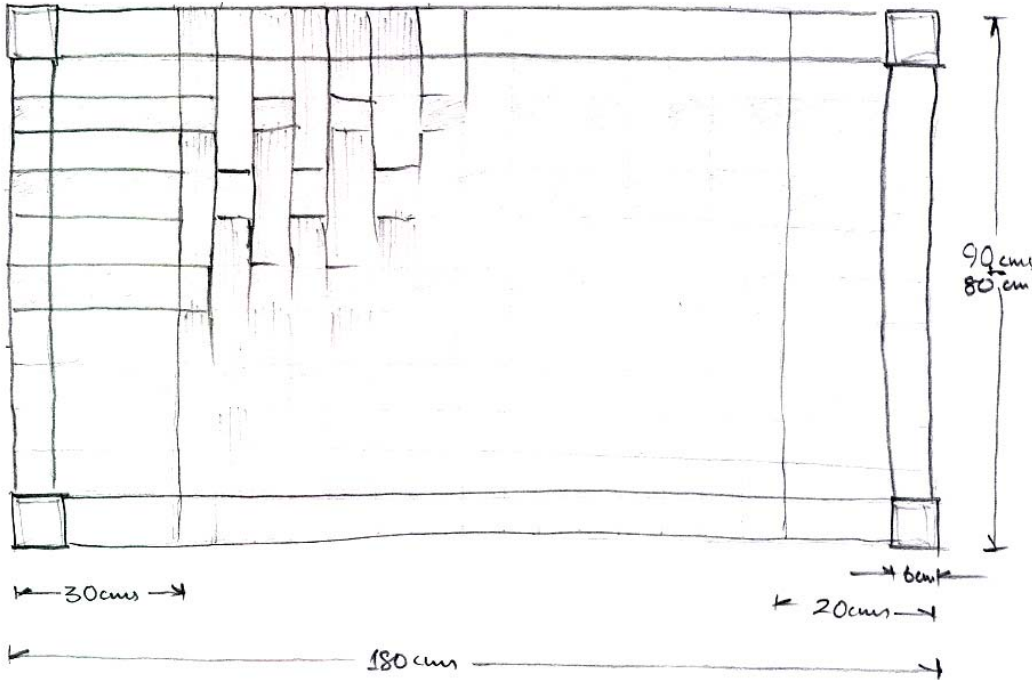

Typical Size

1800(L)
800(W)
450(H)

Light weight
Stackable
Can seat 3-4 people

Problems

Edge hurts when person
is seated

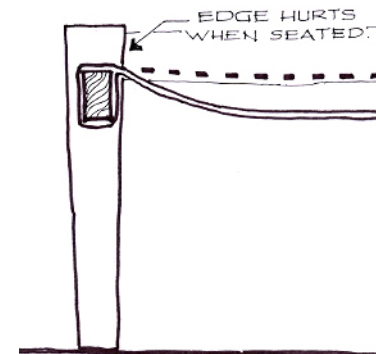
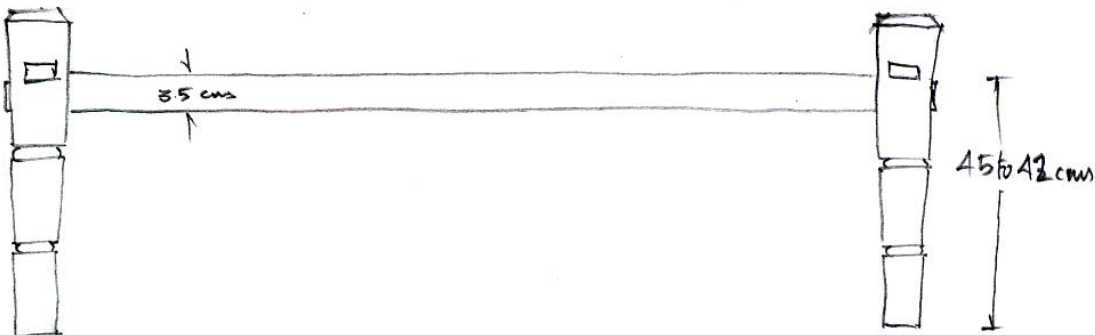

Requirements of New Design

Requirements

- Knock down
- Light weight
- Semantic comparison with existing charpoy
- Mass manufacturing
- Ergonomics
- Maintenance
- Ease in transportation
- Client image



NORMAL SEATING.



EATING ON COT



SLEEPING.



EATING ON TABLE

Concept

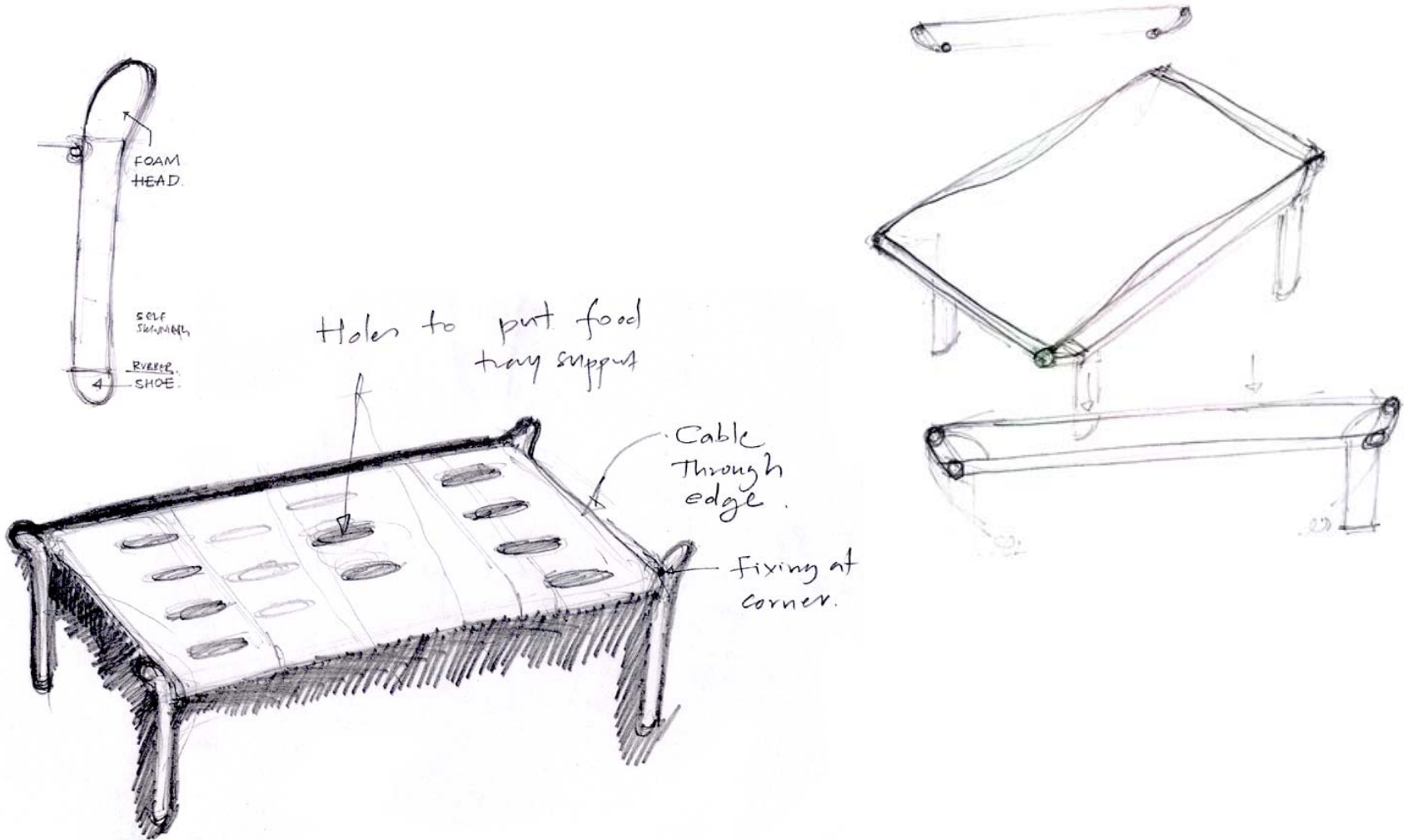

3D models

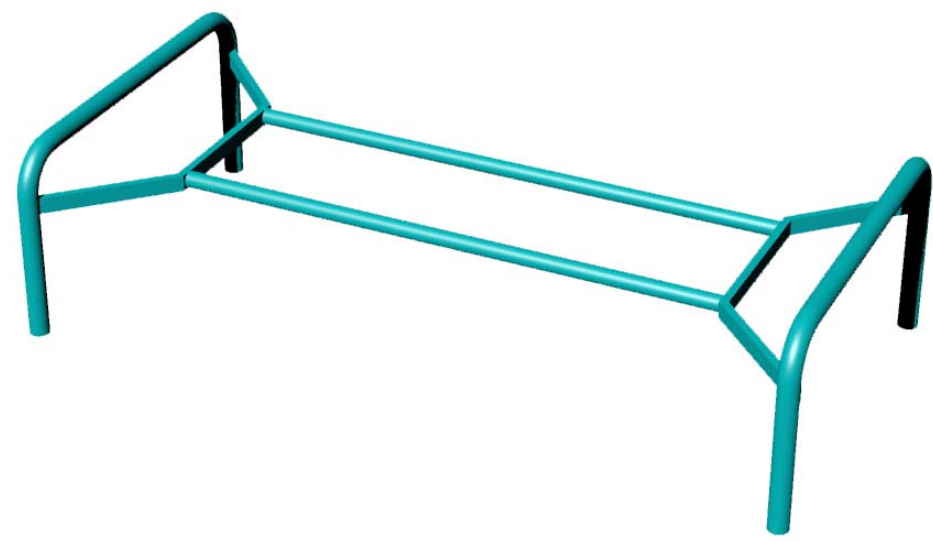
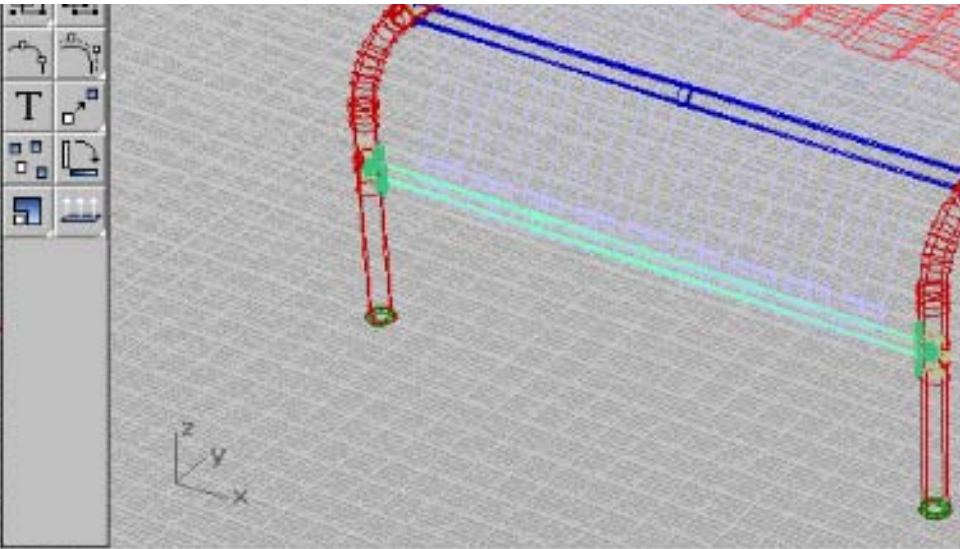
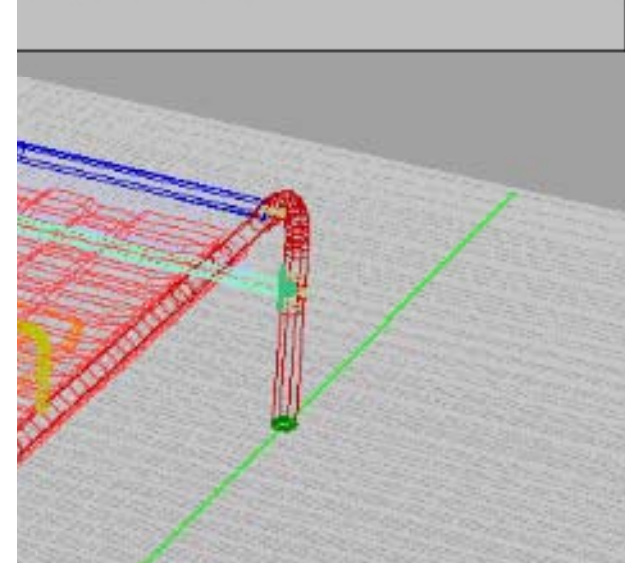
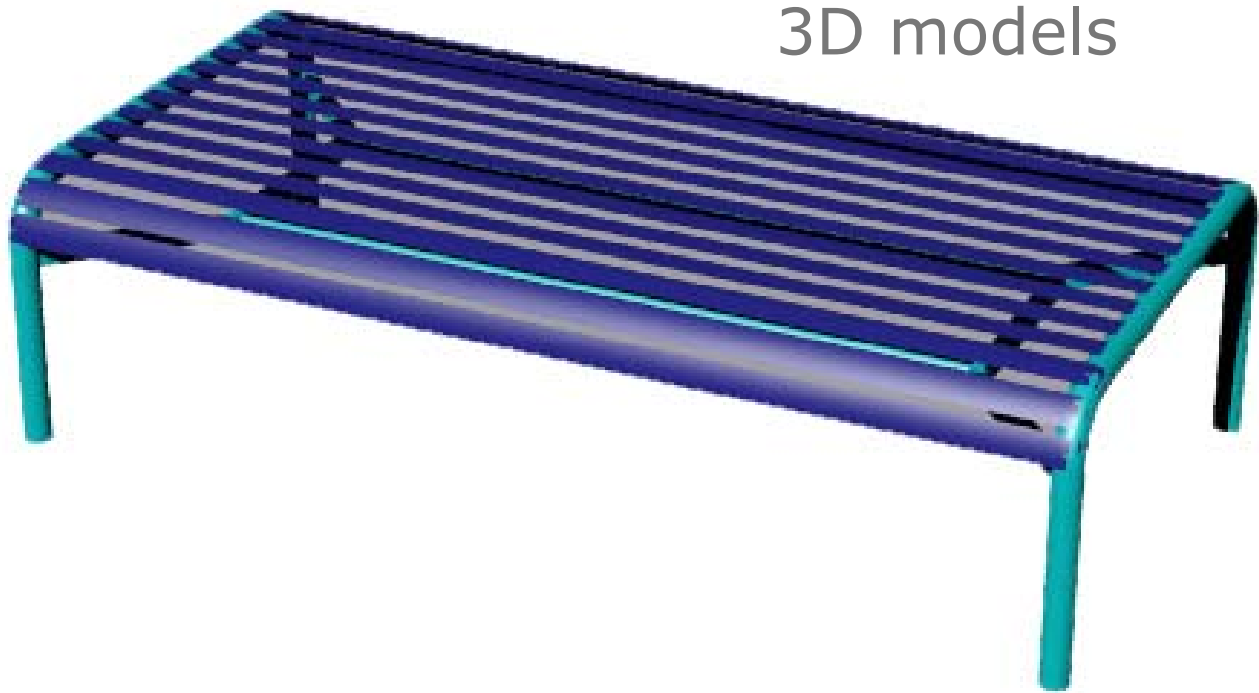

Materials – Exploration & Testing



Materials – Exploration & Testing

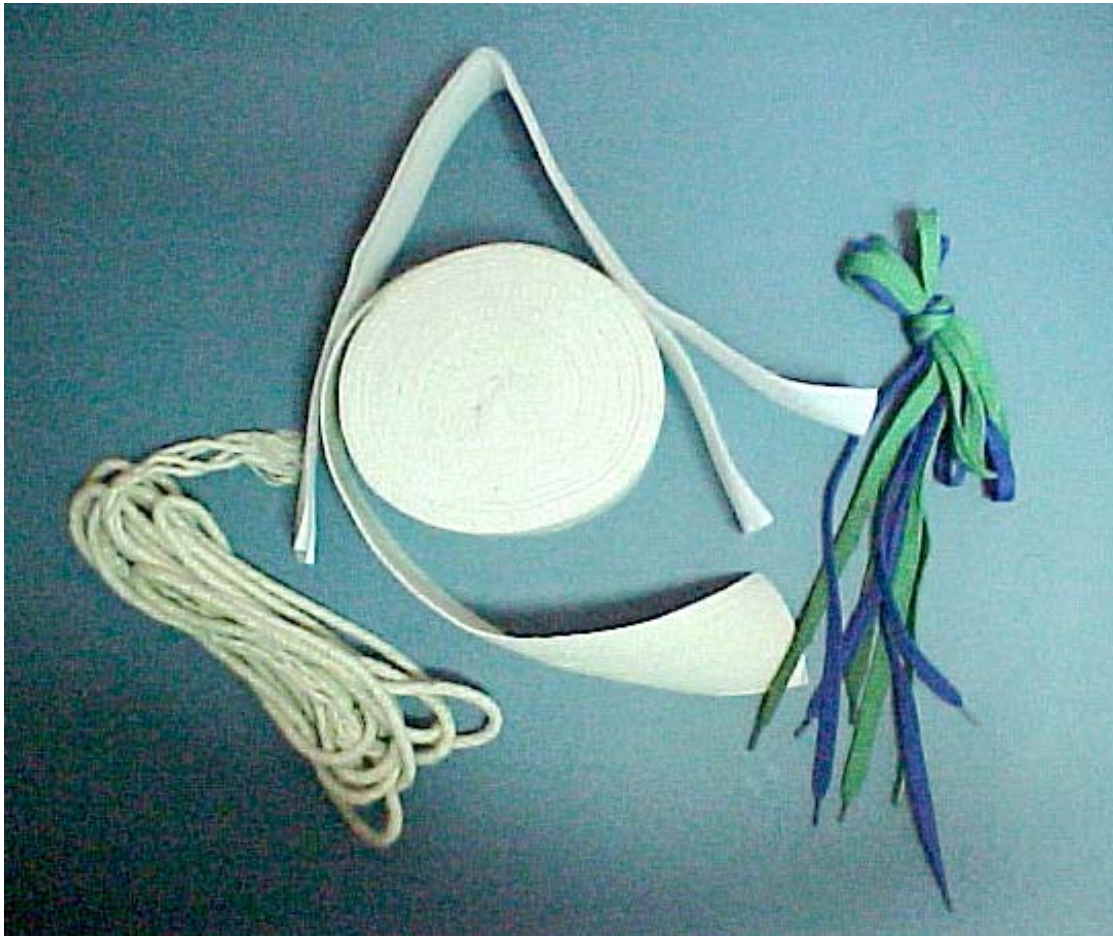

Design

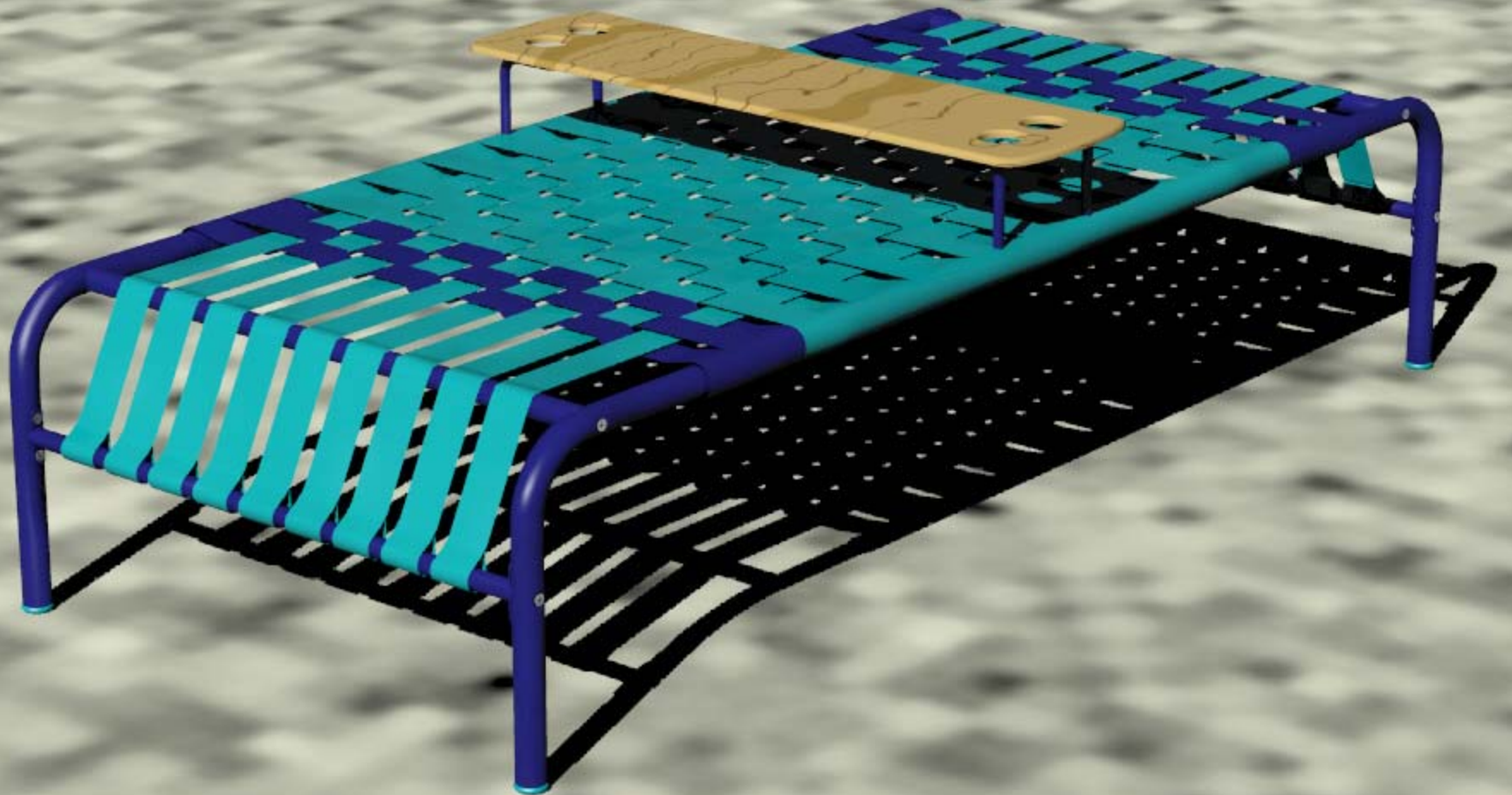

Detailing

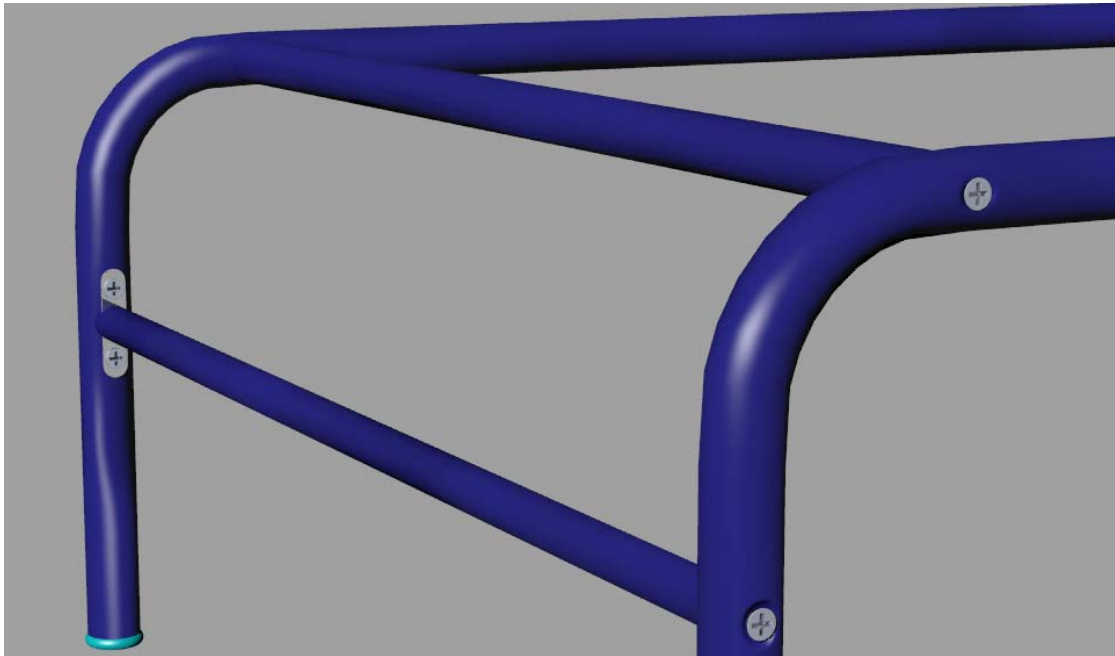

Prototype



Prototype



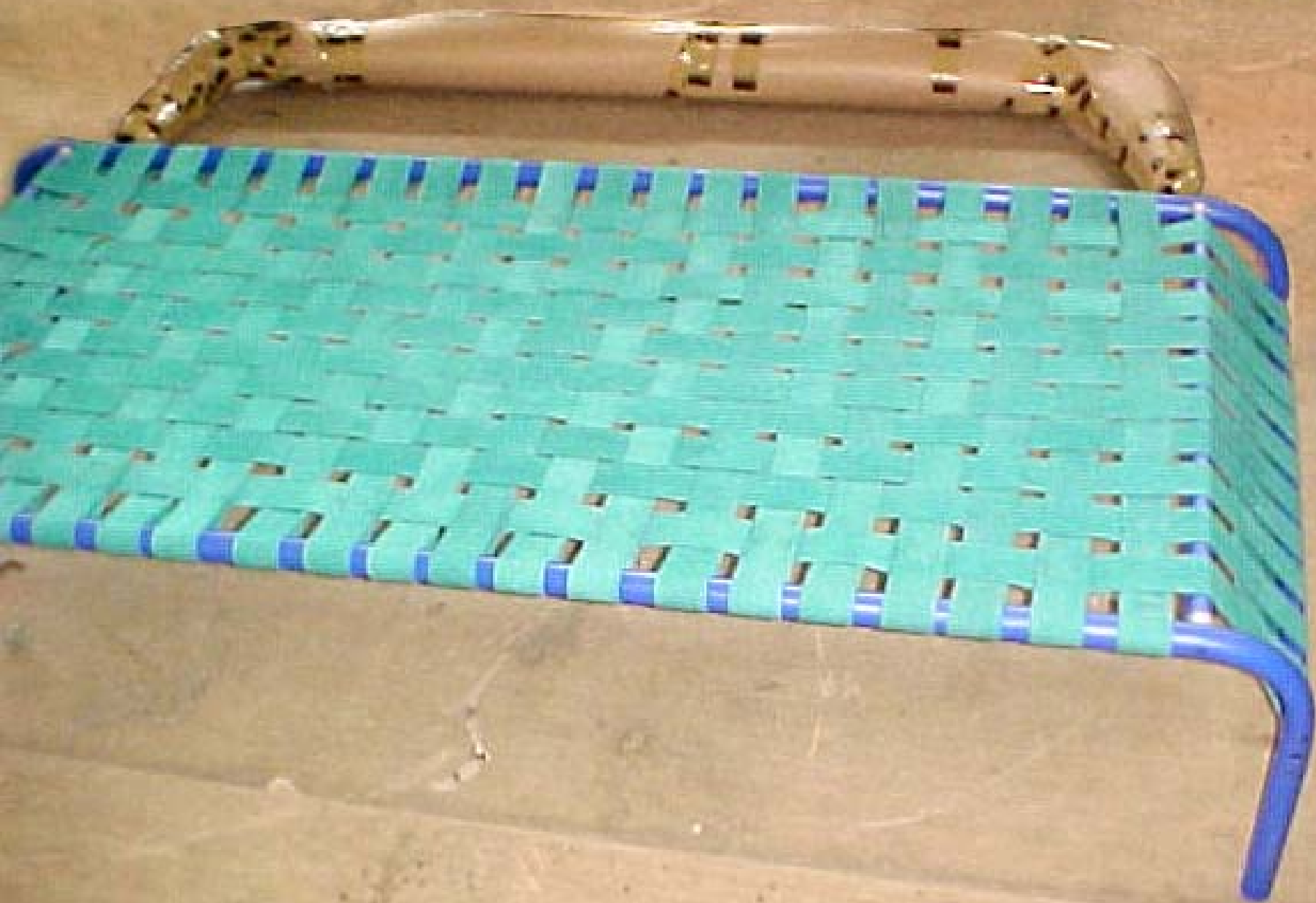

Thank You