

enhancing visual culture in open space

Prof. Raja Mohanty
Project guide

Kshetrimayum Dideswor Singh
156250011

Public sculpture for IIT Bombay

abstract

My own understanding to History of Art, perceive what is visual culture

Rethink about Art and its role in our time

To understand how artist contribute to visual culture of a public space

Public Art around the globe

Possibility of enhancing visual culture in the form of public art inside IIT Bombay

Finally a Public Sculpture of IIT Bombay

objective

To enhance my awareness of contemporary Public Art

Curatorial vision for Public Art at IIT Bombay

To understand the creative and technique possibility of large scale Sculpture

Visual Culture

- The word Visual is related to seeing or appearance, any item or element depending on the sense of sight.
- A Culture is defined as a social domain emphasises the practices, discourse and material expression which over time expire the continuities and discontinuities of social meaning of a life held in common.
- So Visual culture is a form of culture expressed in visual images

Public Art

Importance of Public Art

- It is a reflection of how we see the world.
- It is kind of a mirror image of a community.
- Public Art becomes a reflection of a place and the time.
- It encourages to think and increase our awareness of a community.
- It enhance our Environment and can transformed a landscape.

Public Art around the world



Public Art in India



© Heels & Coffee Beans © Heels & Coffee Beans © Heels & Coffee Beans © Heels & Coffee Beans

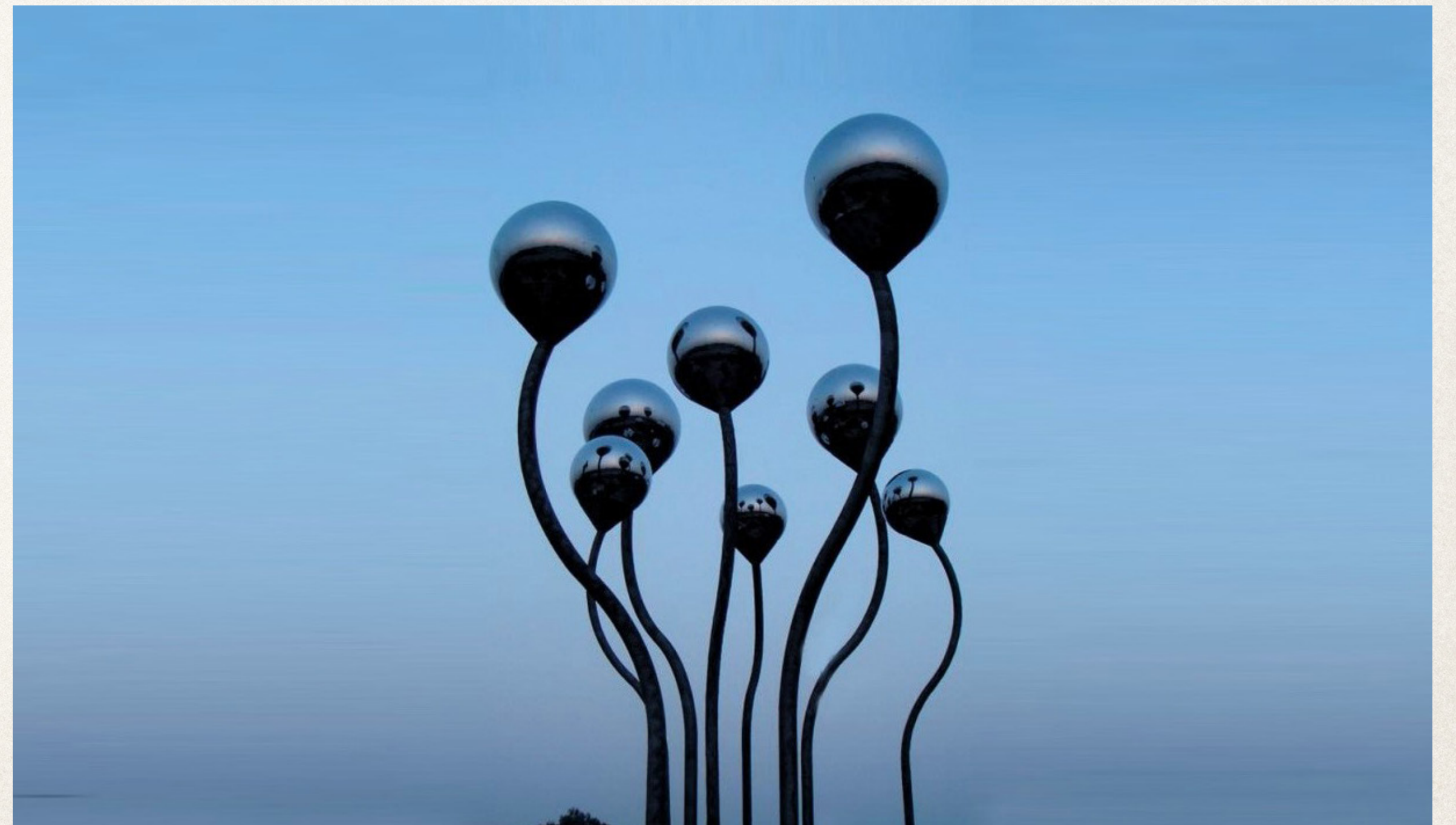





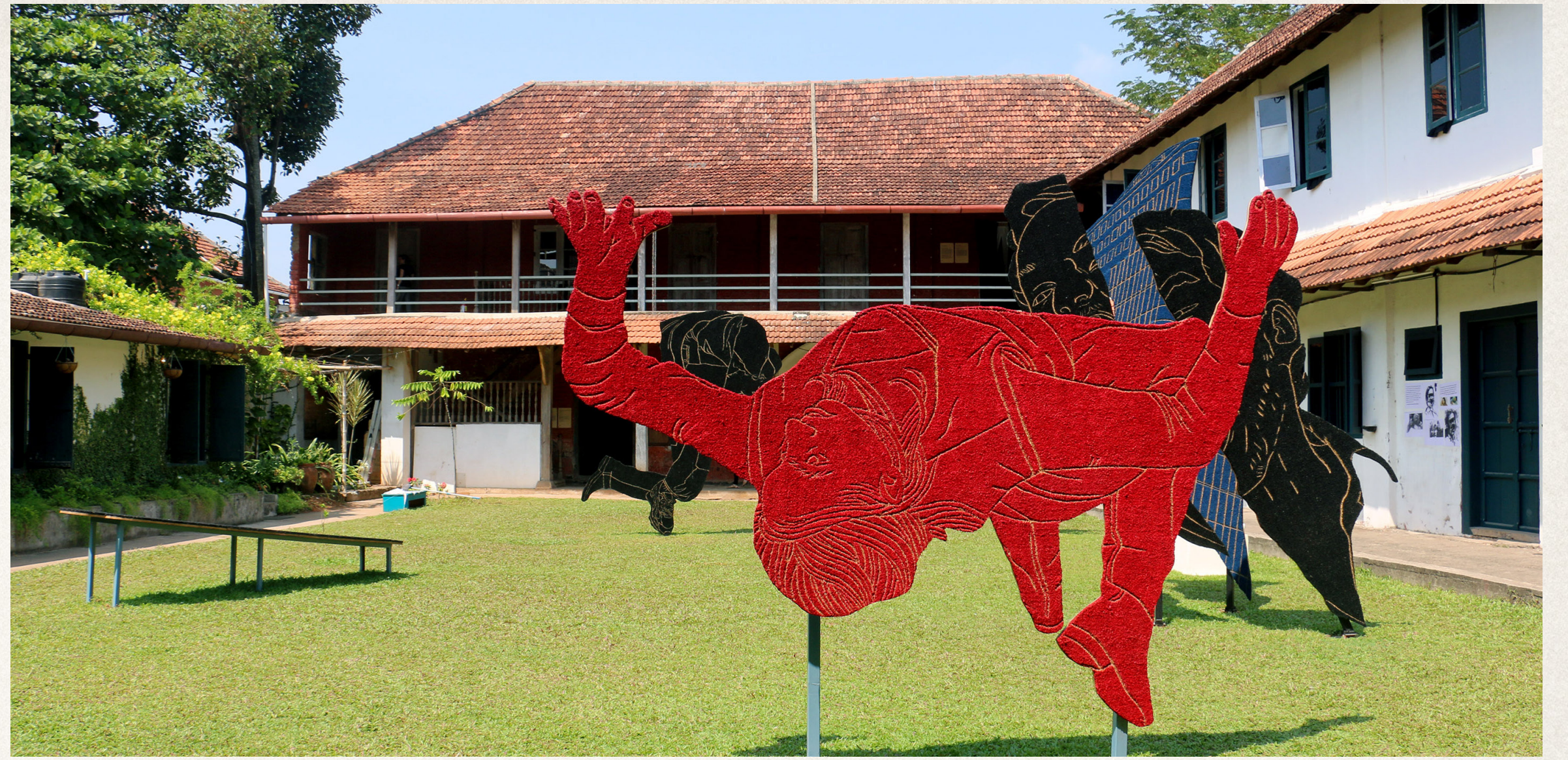



Public Art in Mumbai







Public Art at IIT Bombay













Lots of free spaces





IDC School of Design
अभिकल्प विद्यालय









Master Plan

- 10–20 year aesthetic masterplan
- Step to beautify the campus
- Curatorial Vision

Some Possibility







Public Sculpture for IIT Bombay

Friends



True Knowledge



Water





Student Aspiration



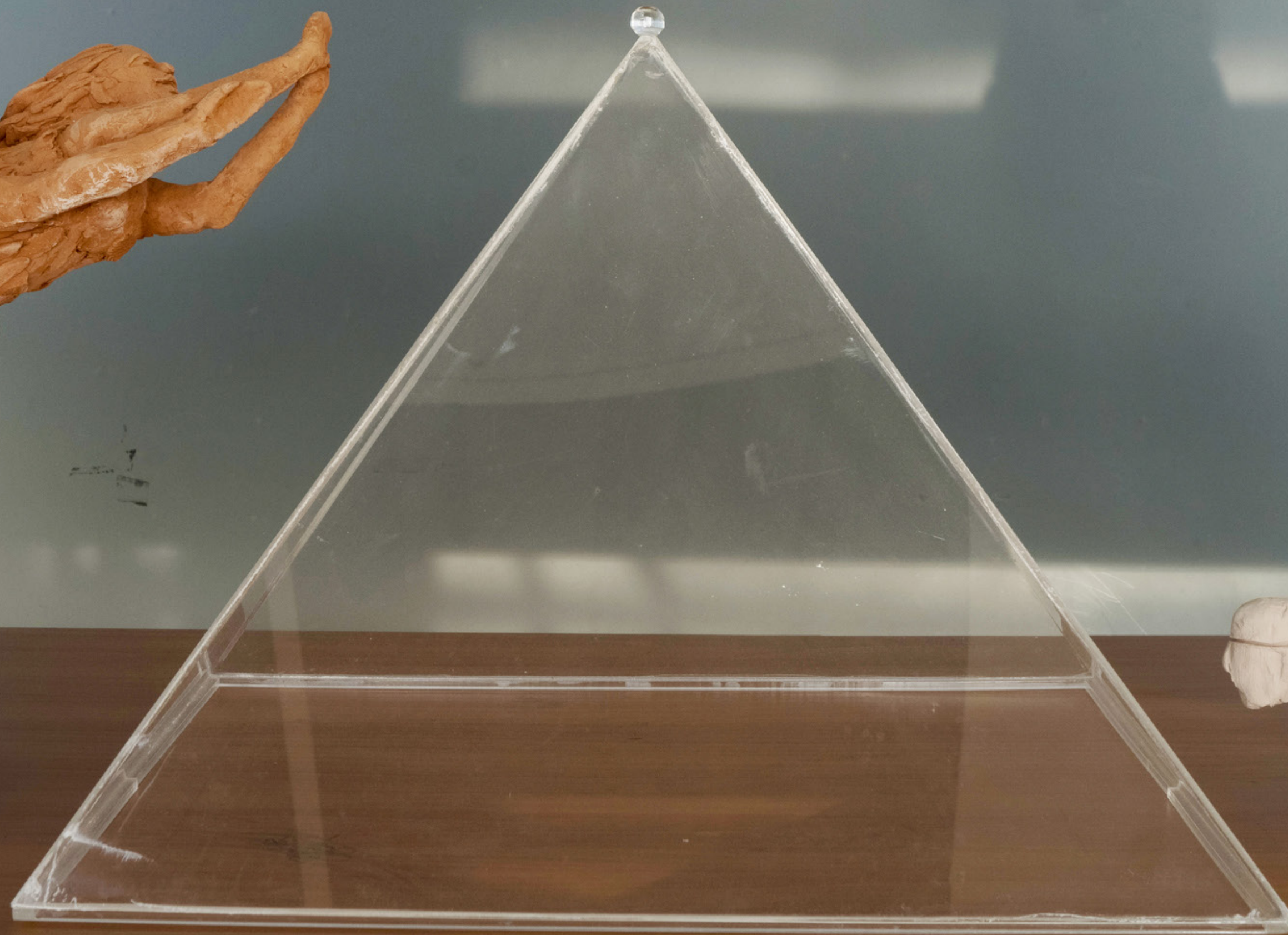
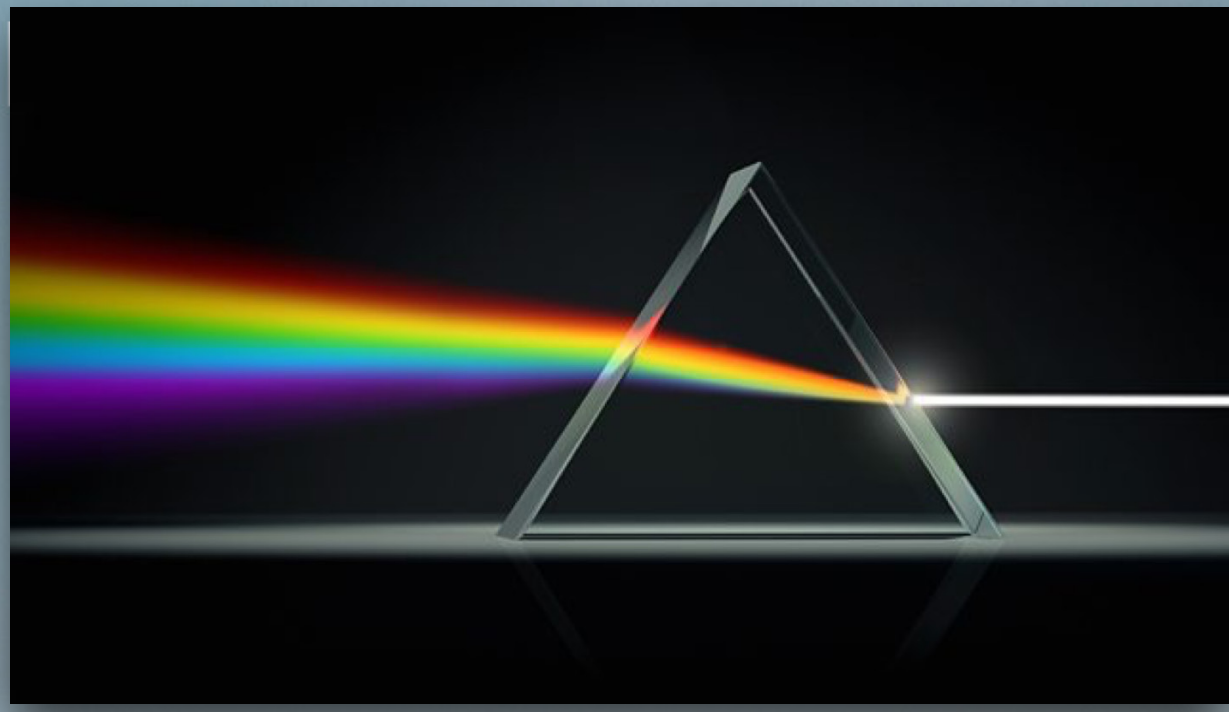

Final concepts

Zero

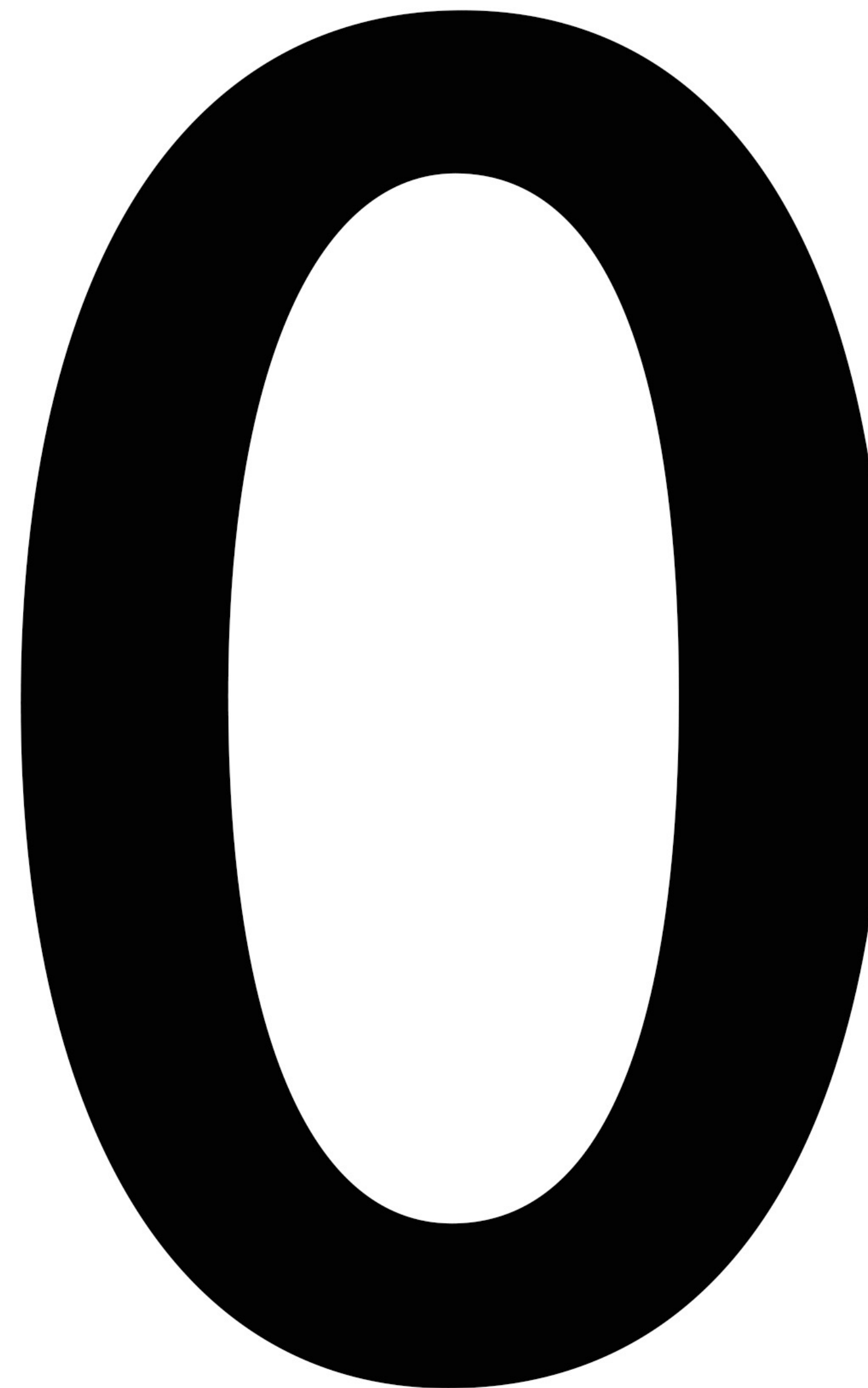

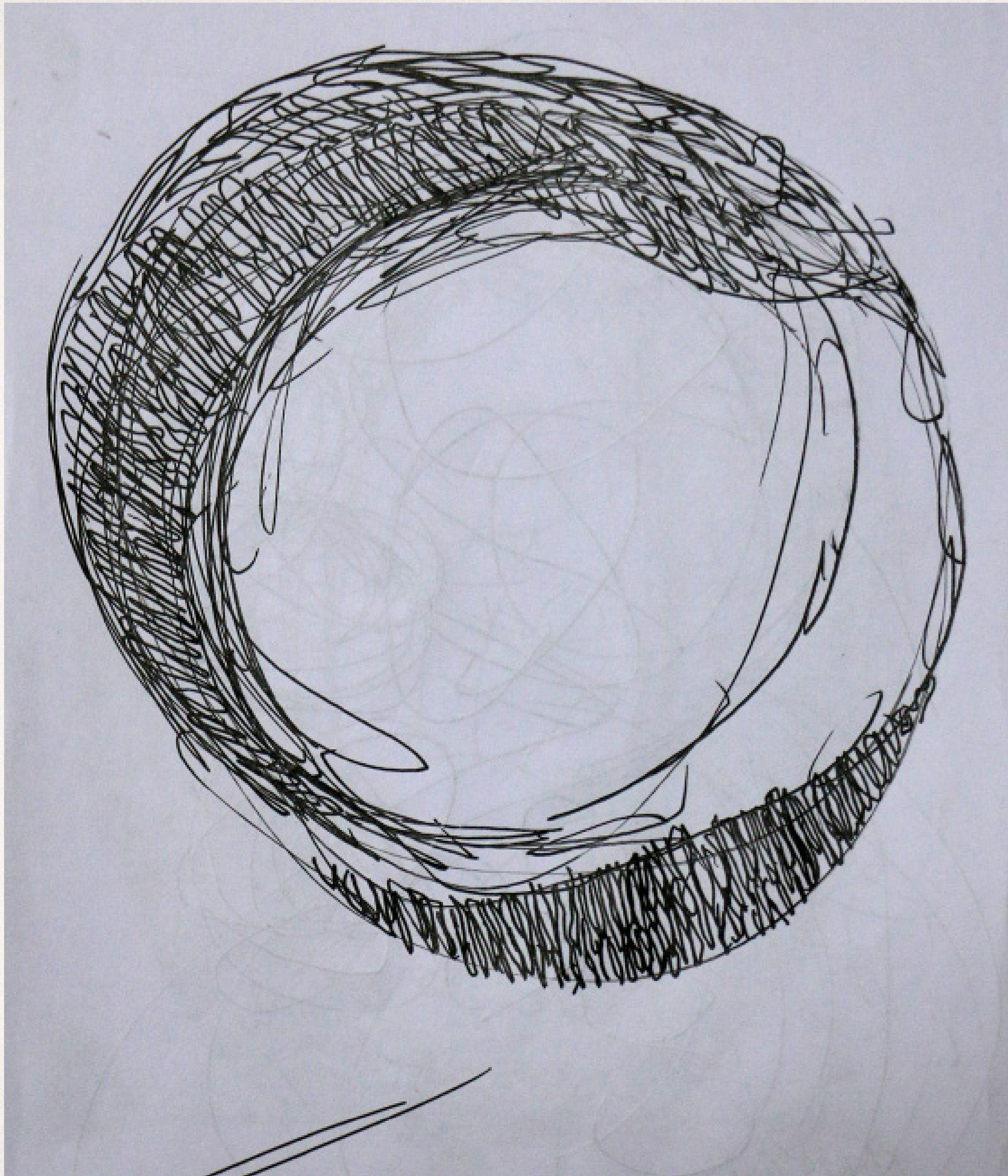
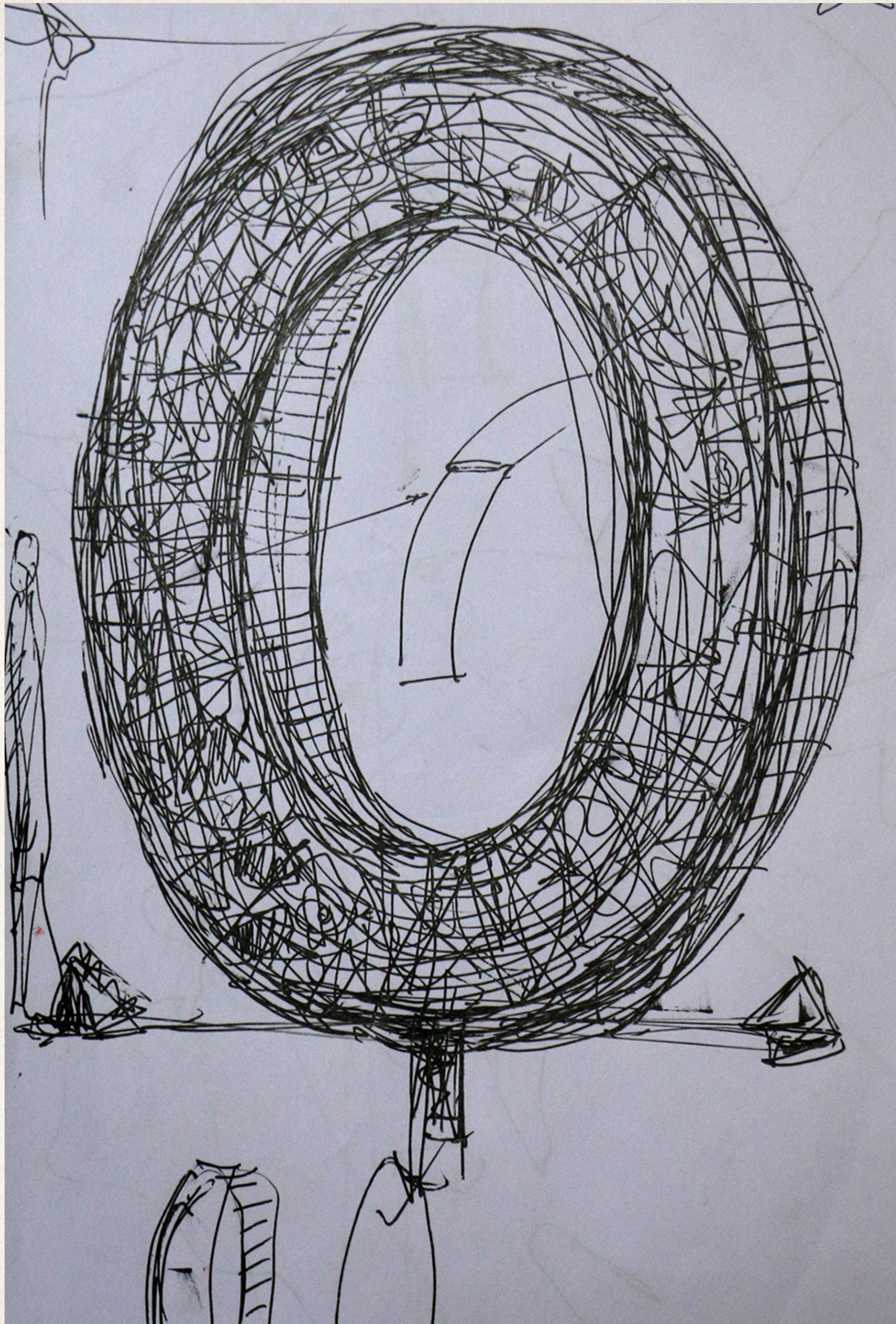

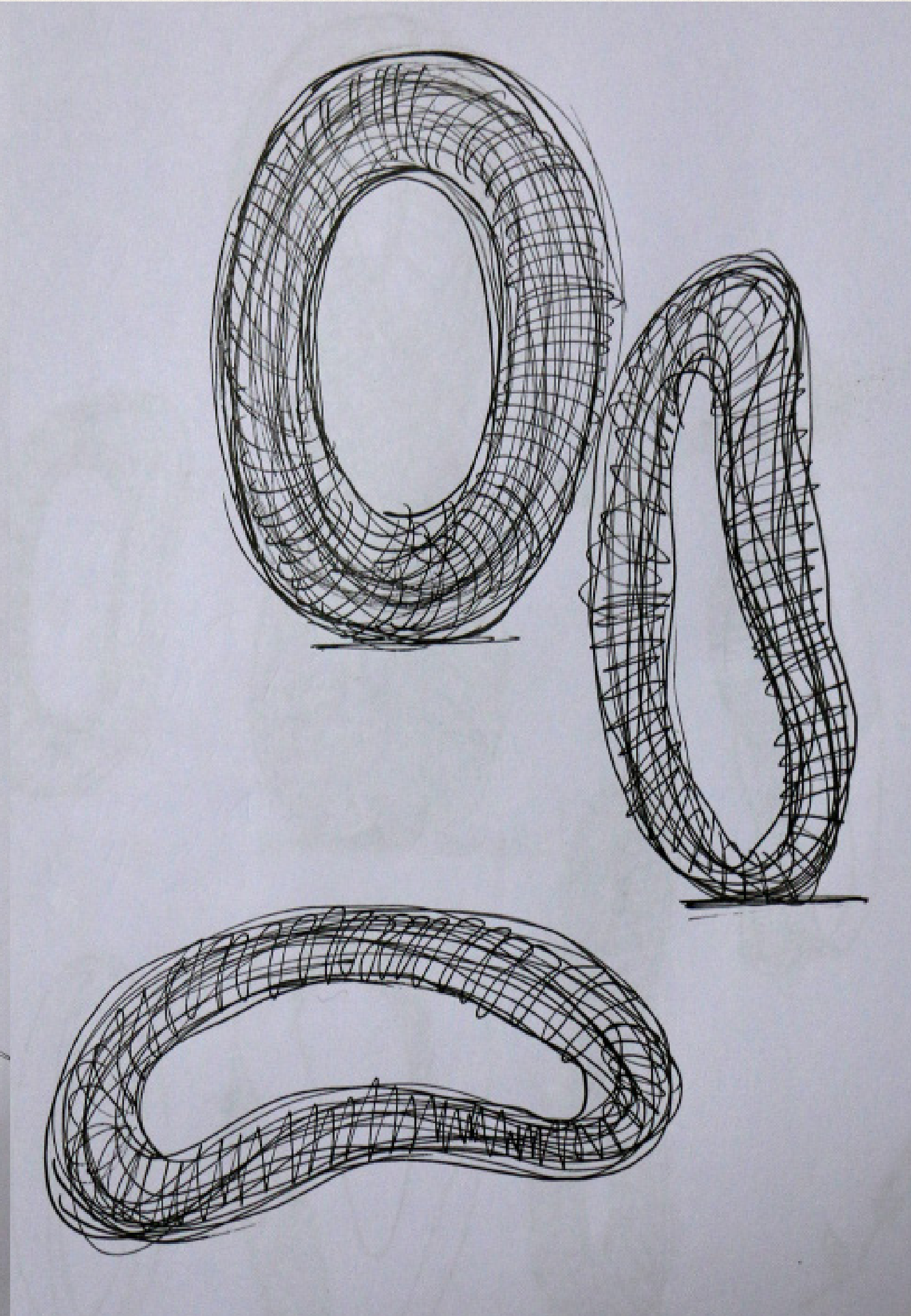
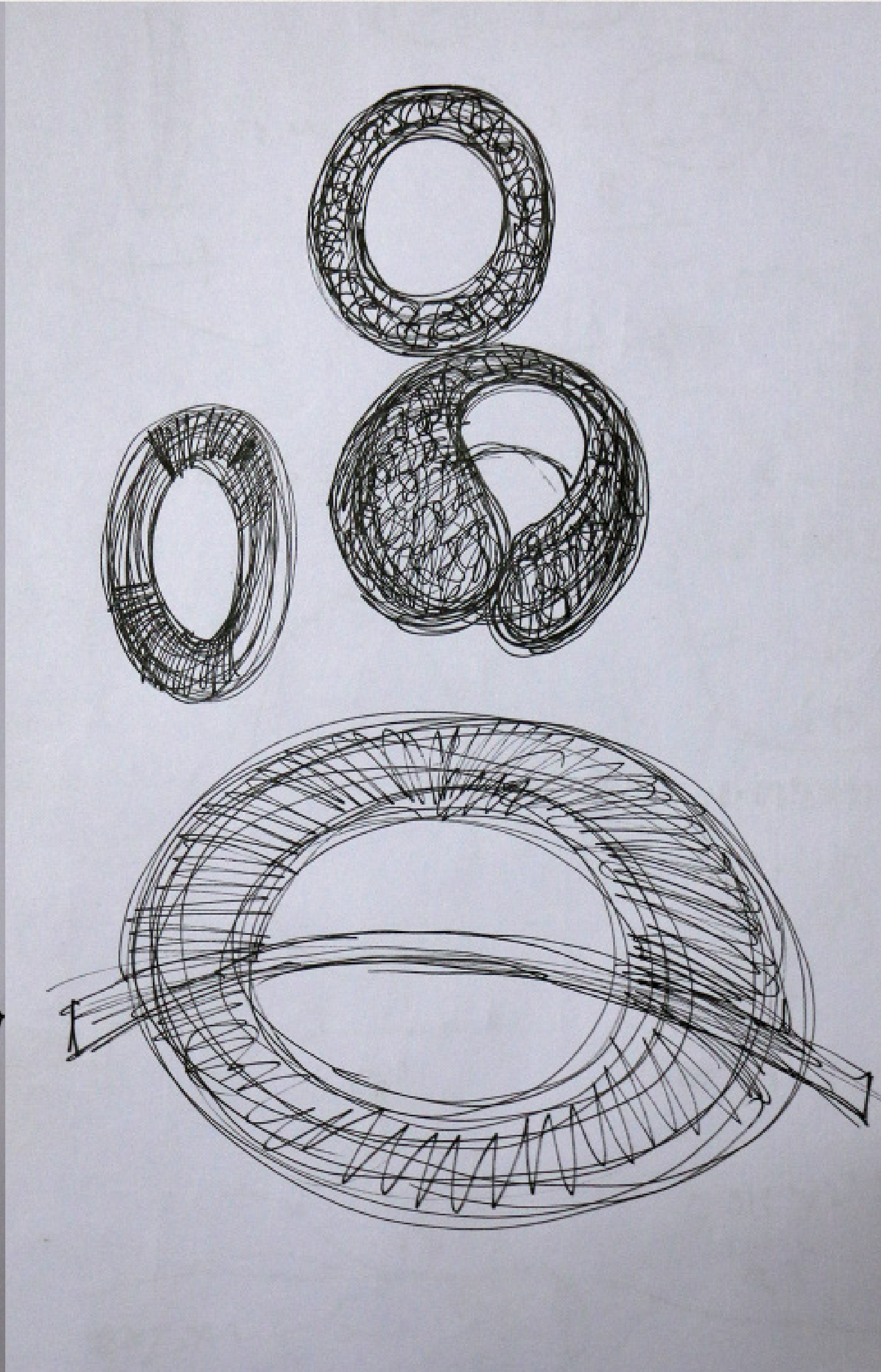
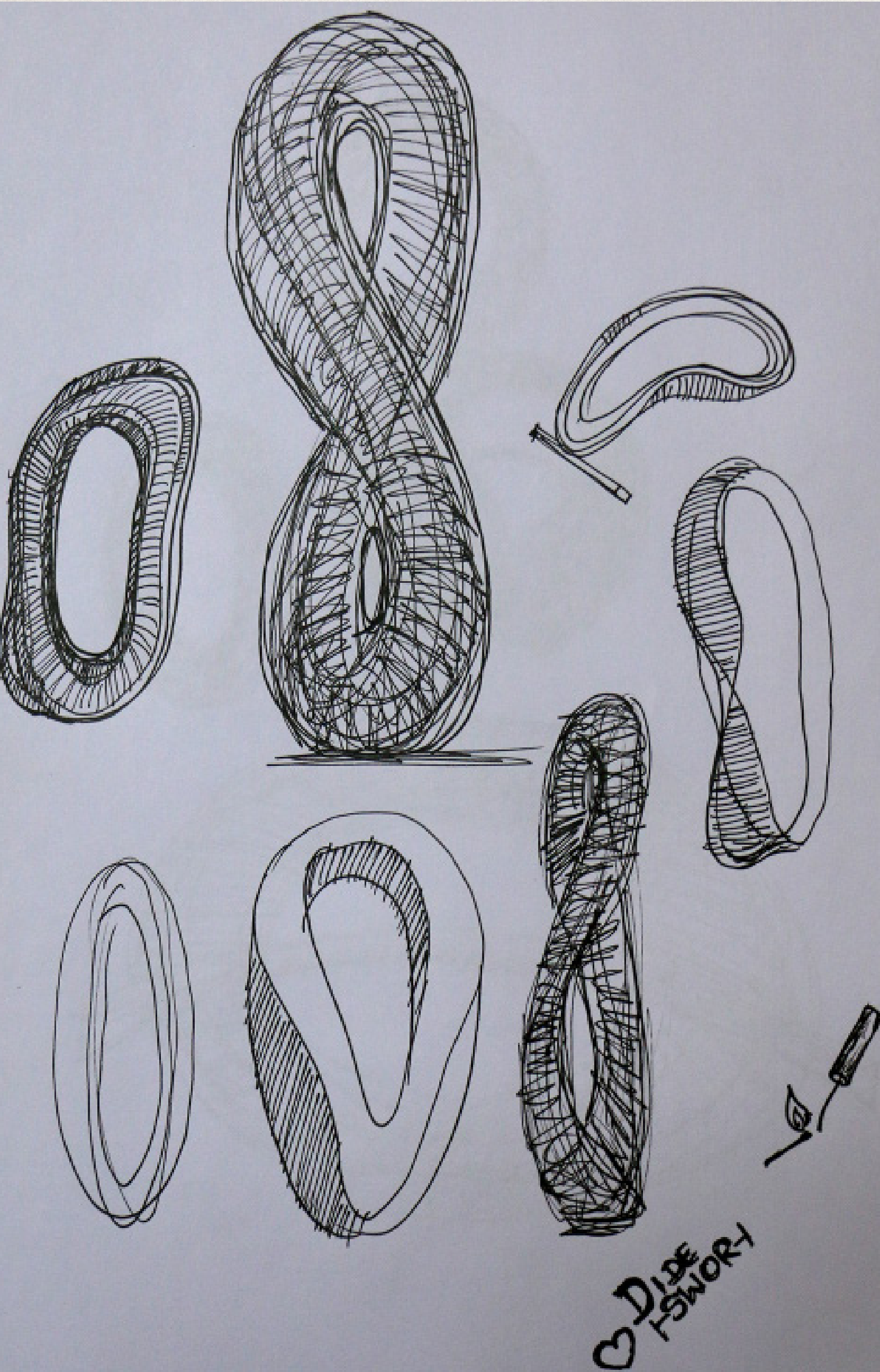

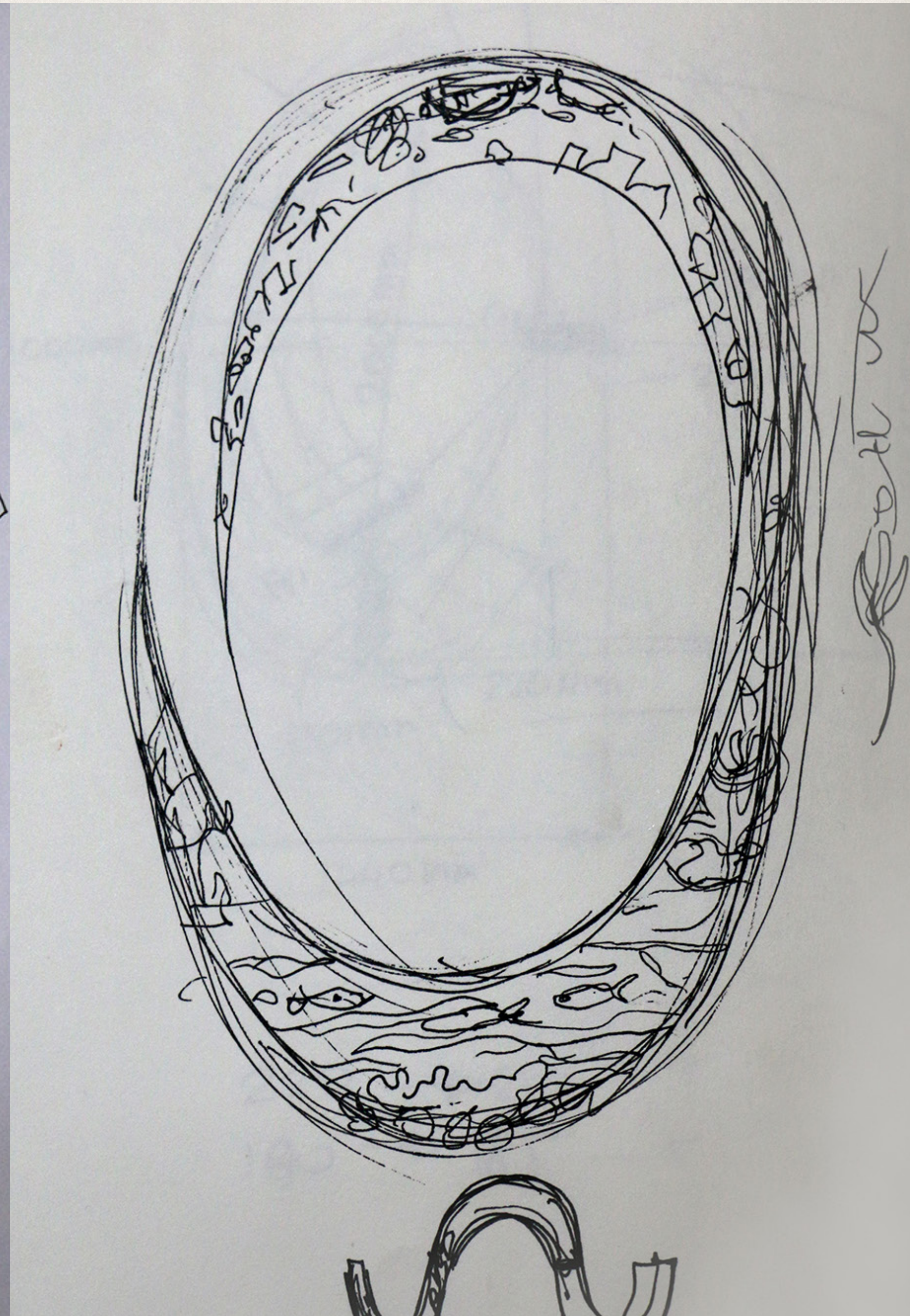
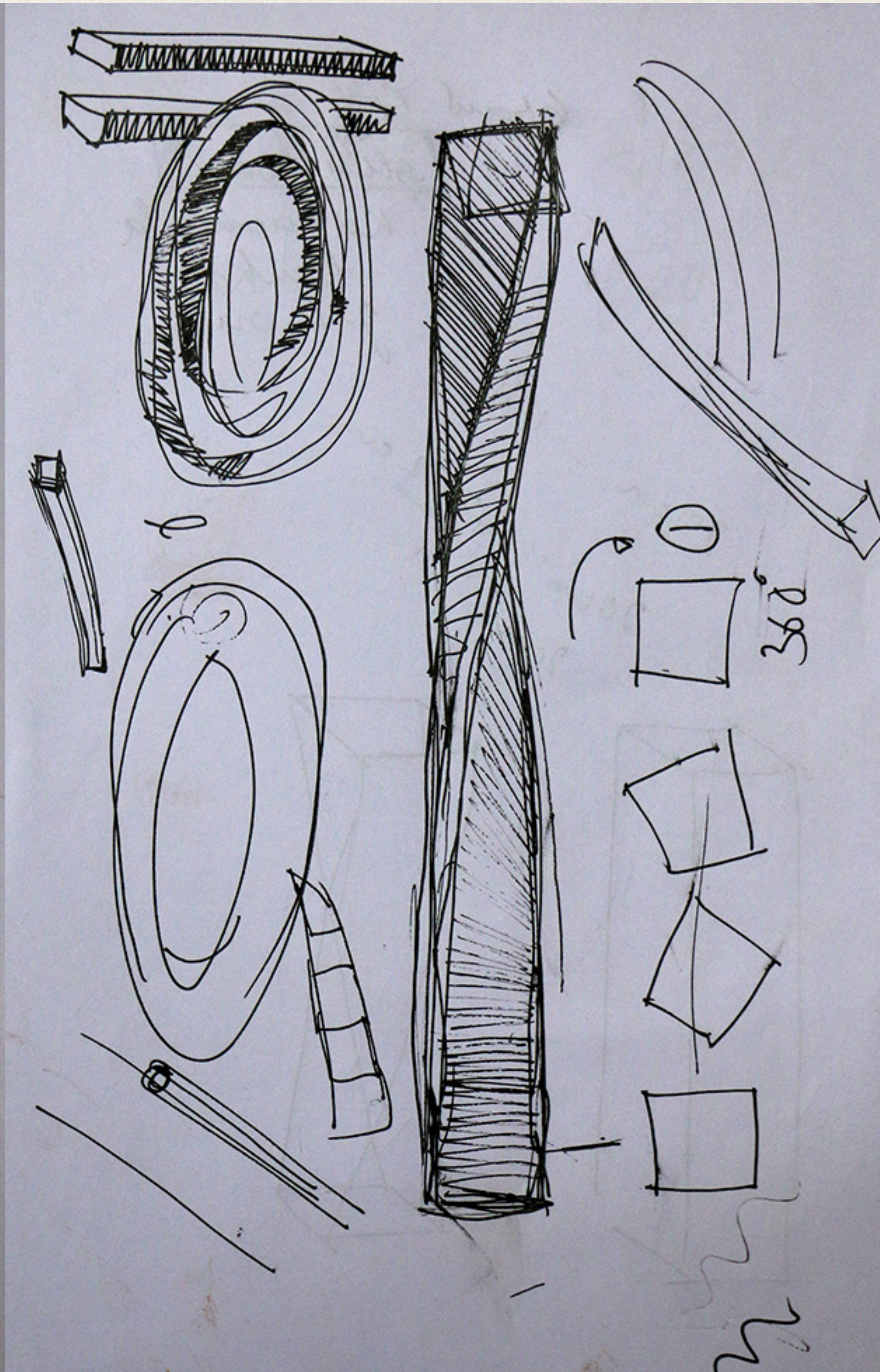
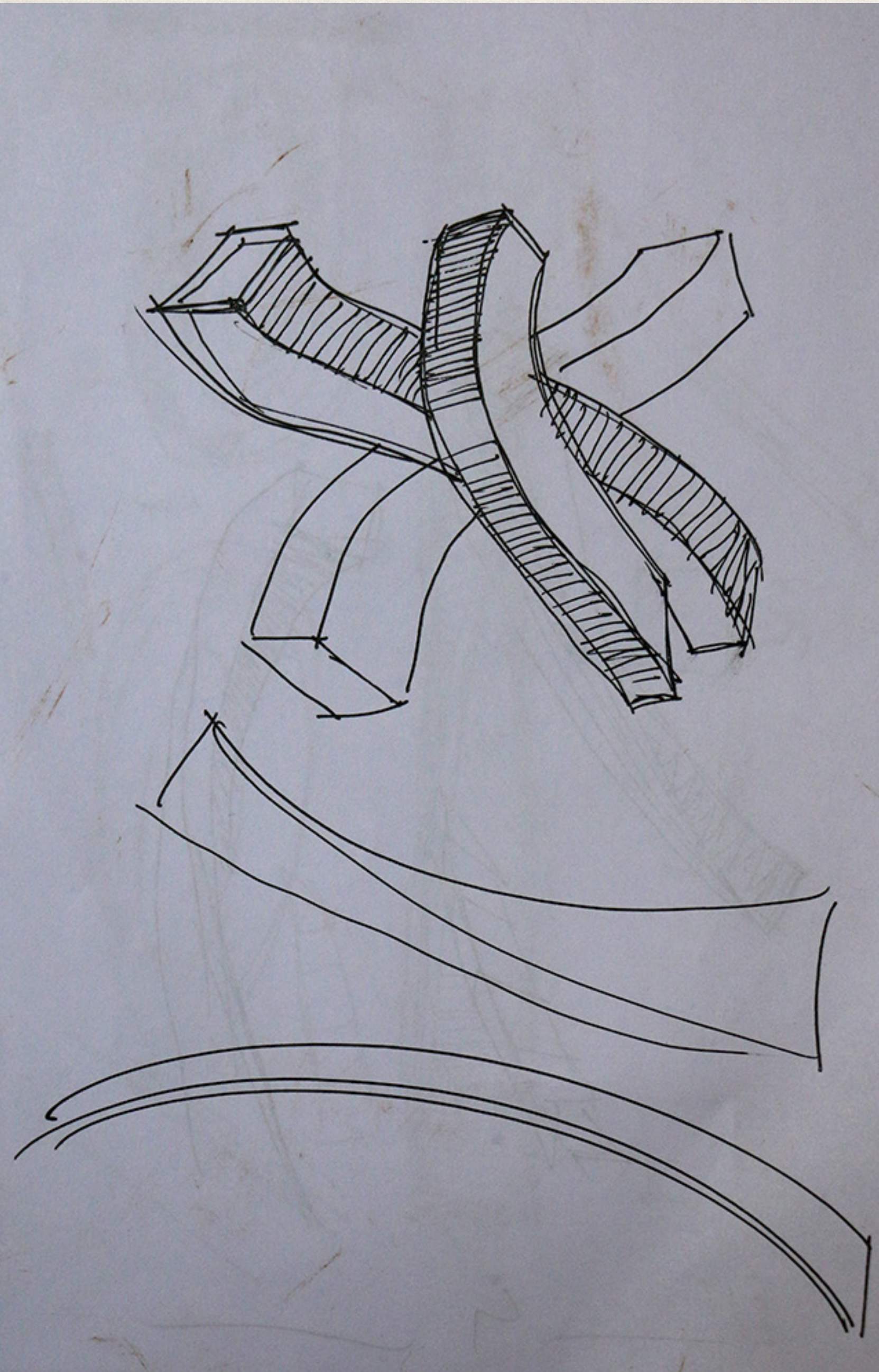



Budget & Funding

Material

Fabrication Process

1. Main Structure
2. Illustration
3. Foundation

Main structure



ttte

ntbx nw cos text...

Curve Edit

Object Edit

Surfaces

here planar revolve

kin rail square

fillet filflan

und msdrft crvnet

bsrf ballcm stnsn

msh

Surface Edit

ject trim stch

sub plhull rebsrf

ymt fit scan setor

wuv ntb

Mesh

View

Construction

Locators

wloc annot distance

pt crvcvtr

Evaluate

Point Clouds

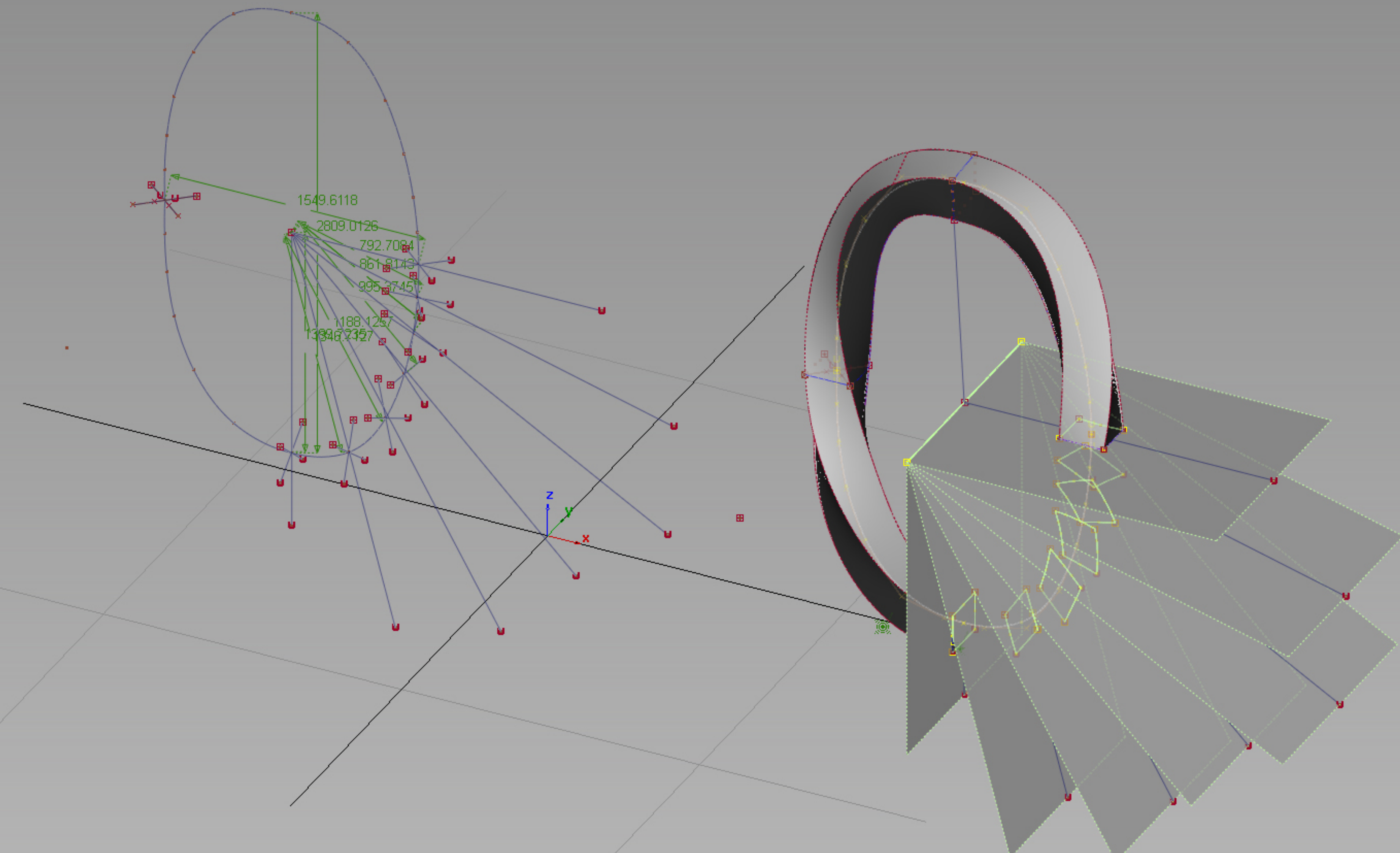

Orthographic

Control Panel

Default

Shelf Options

eskis tours help

Menu Shortcuts

pallet objlst infwn ckmod

invis vis hdun tmpl

group ungrp qryed

11 picked objects

Degree

Spans

Display

Deviation

Cv/Hull

Edit Points

Blend Points

Isoparm U v

Curvature U v

xfmncv scnsrf curva xsedit

Diagnostic Shade

shdnon mulcol rancol curevl

isoang horver surevl usetex

ltunnel clayao sophotes vred

vis1 vis2 vis3 filest

Tolerance

0.1000

Tessellator Fast

Layer None

Show Orientation

Color

Specularity

0.100

Transparency

10 feet model

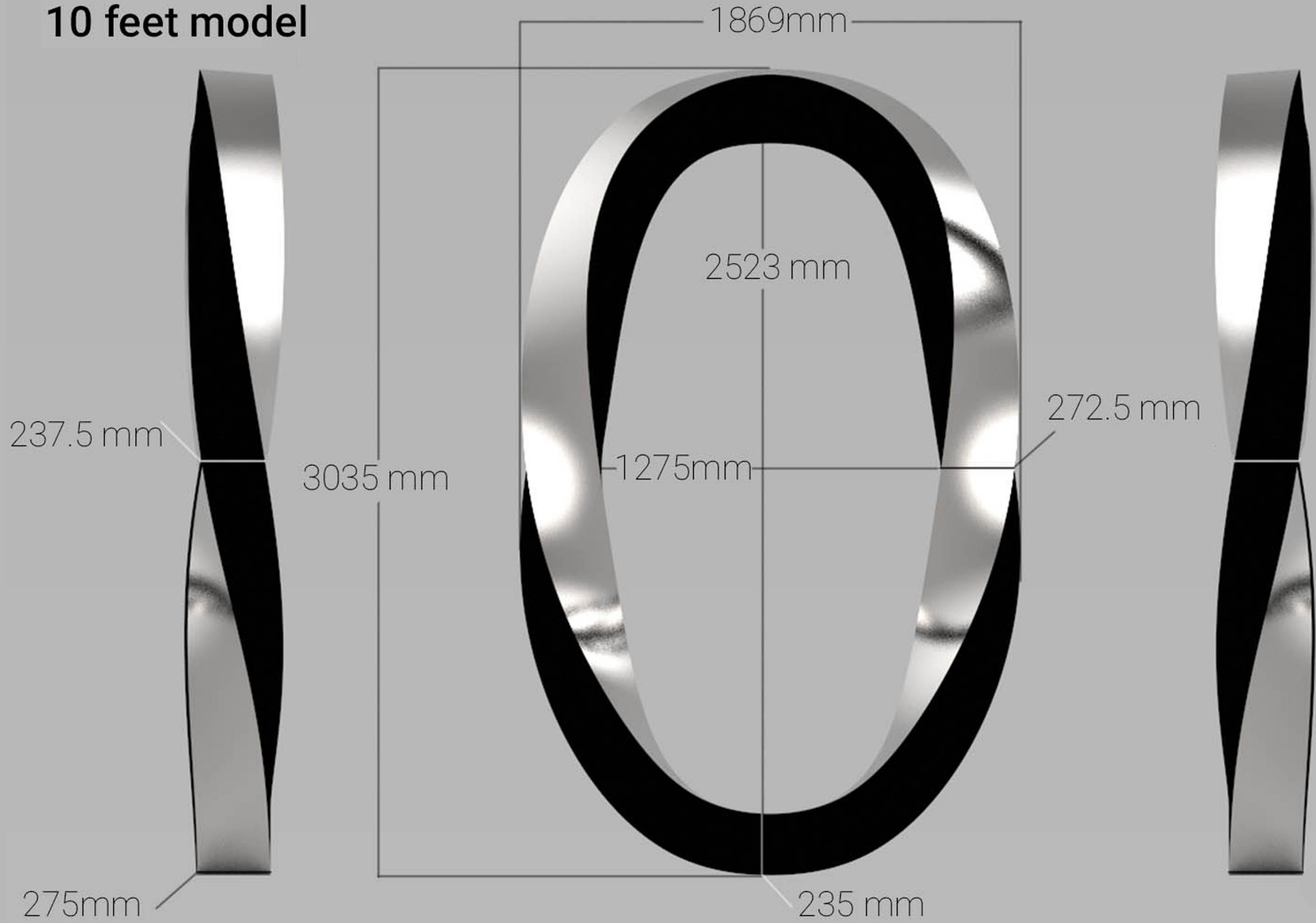

Curve Edit

Object Edit

Surfaces

Surface Edit

Mesh

View

Construction

Locators

Evaluate

Point Clouds

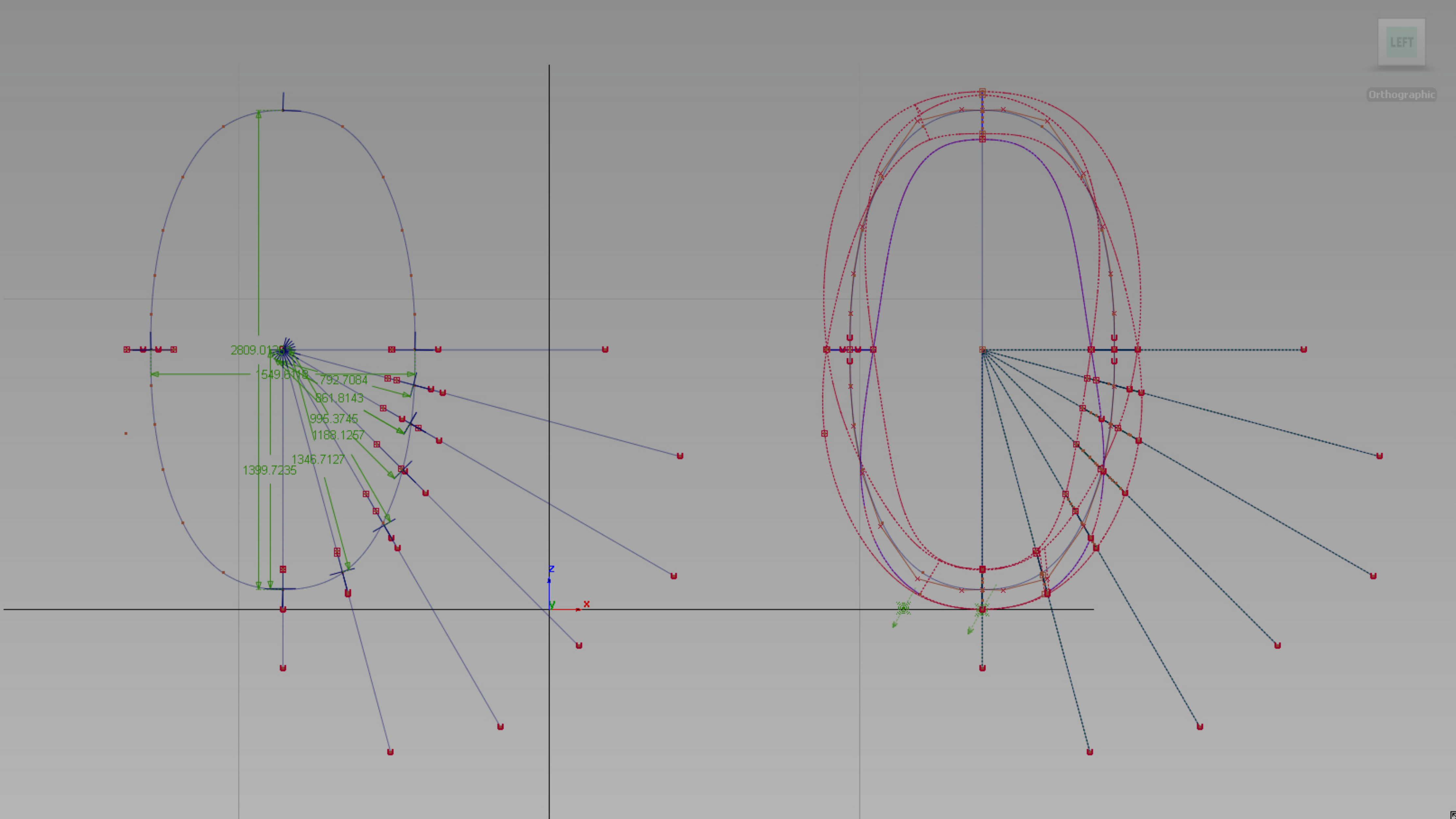

Control Panel

Default

Shelf Options

Menu Shortcuts

0 picked objects

Degree

Spans

Display

Deviation

Cv/Hull

Edit Points

Blend Points

Isoparm U

Curvature U

Diagnostic Shade

Tolerance: 0.1000

Tessellator: Fast

59















Illustration

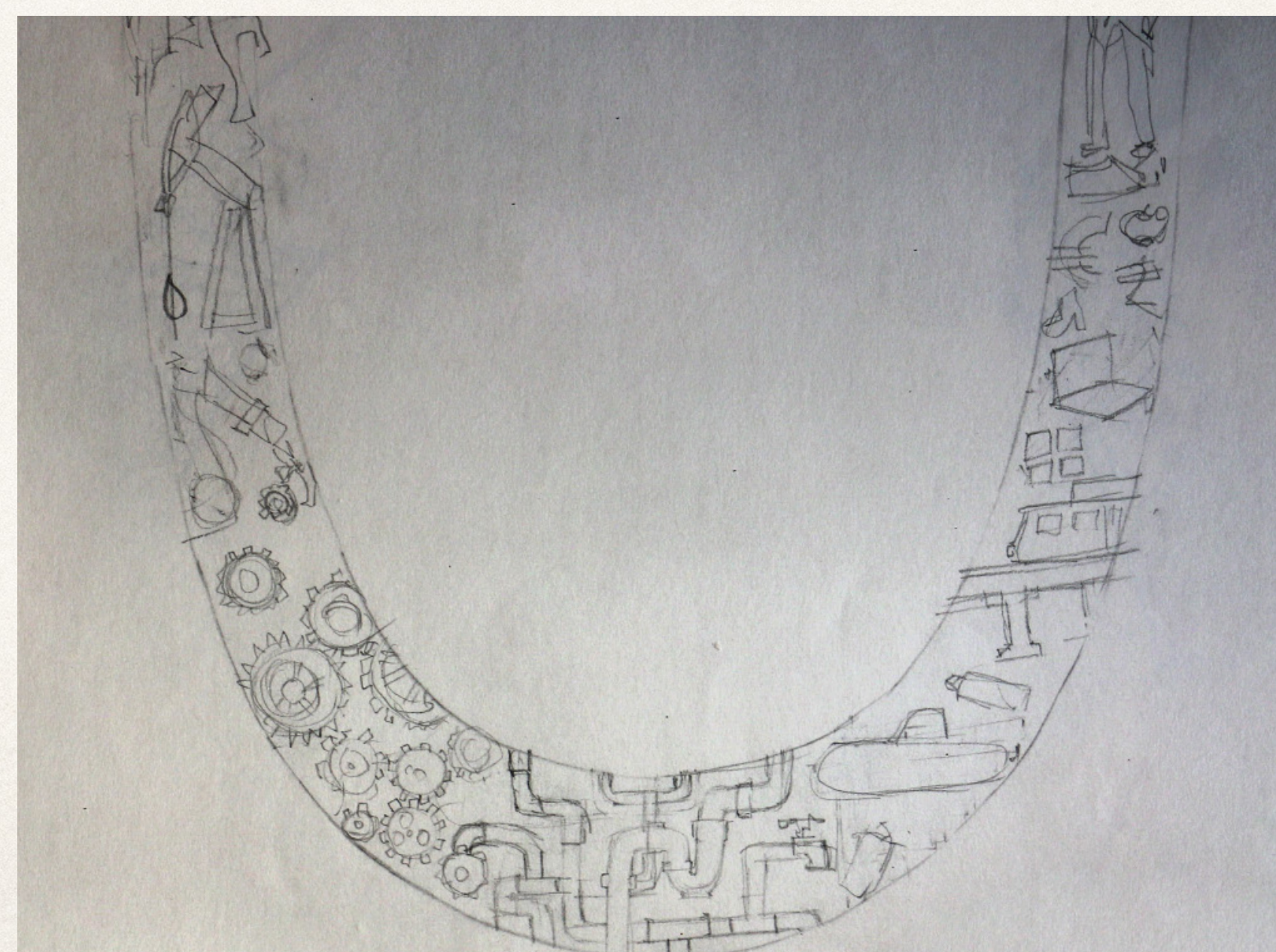
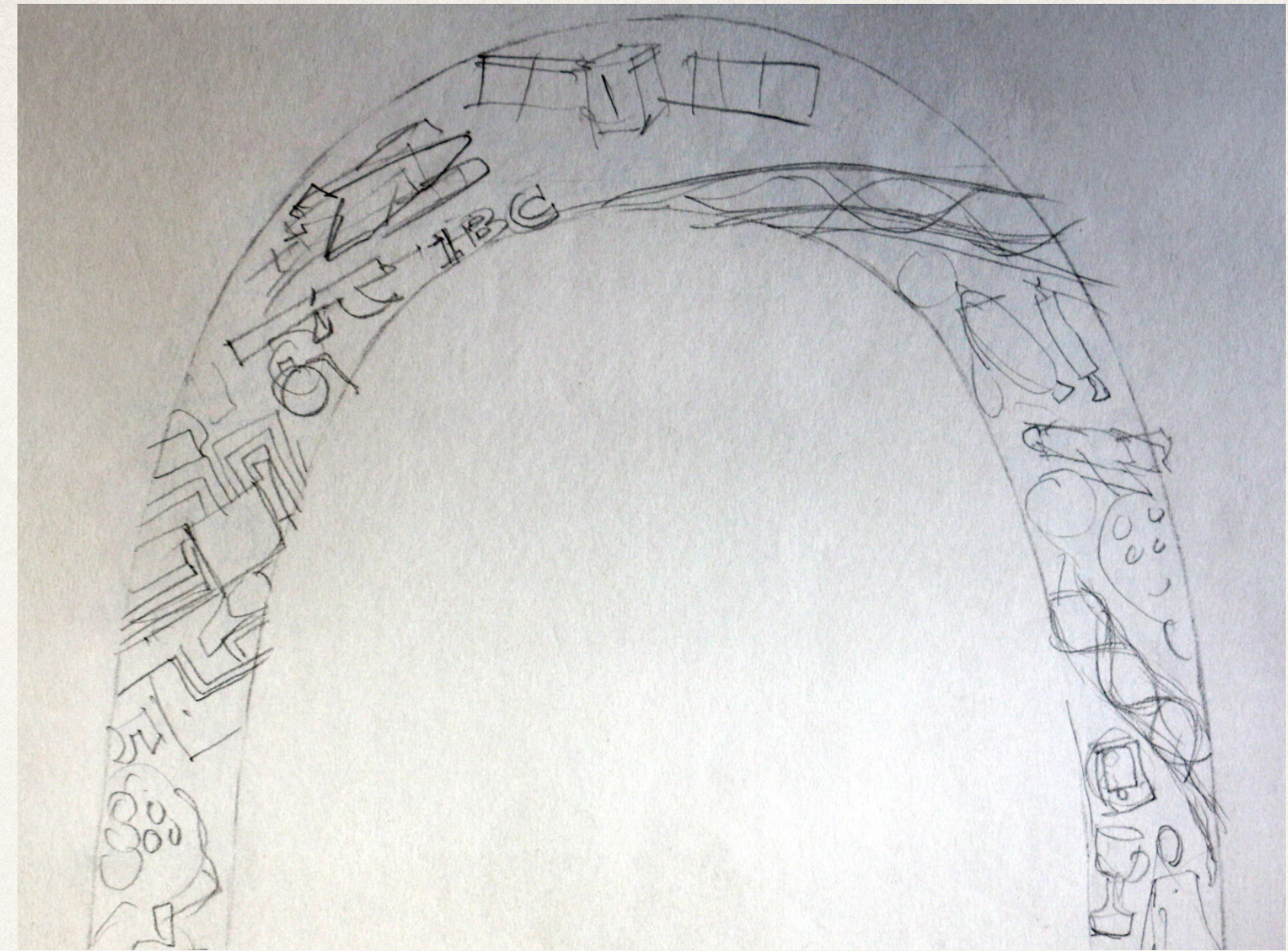
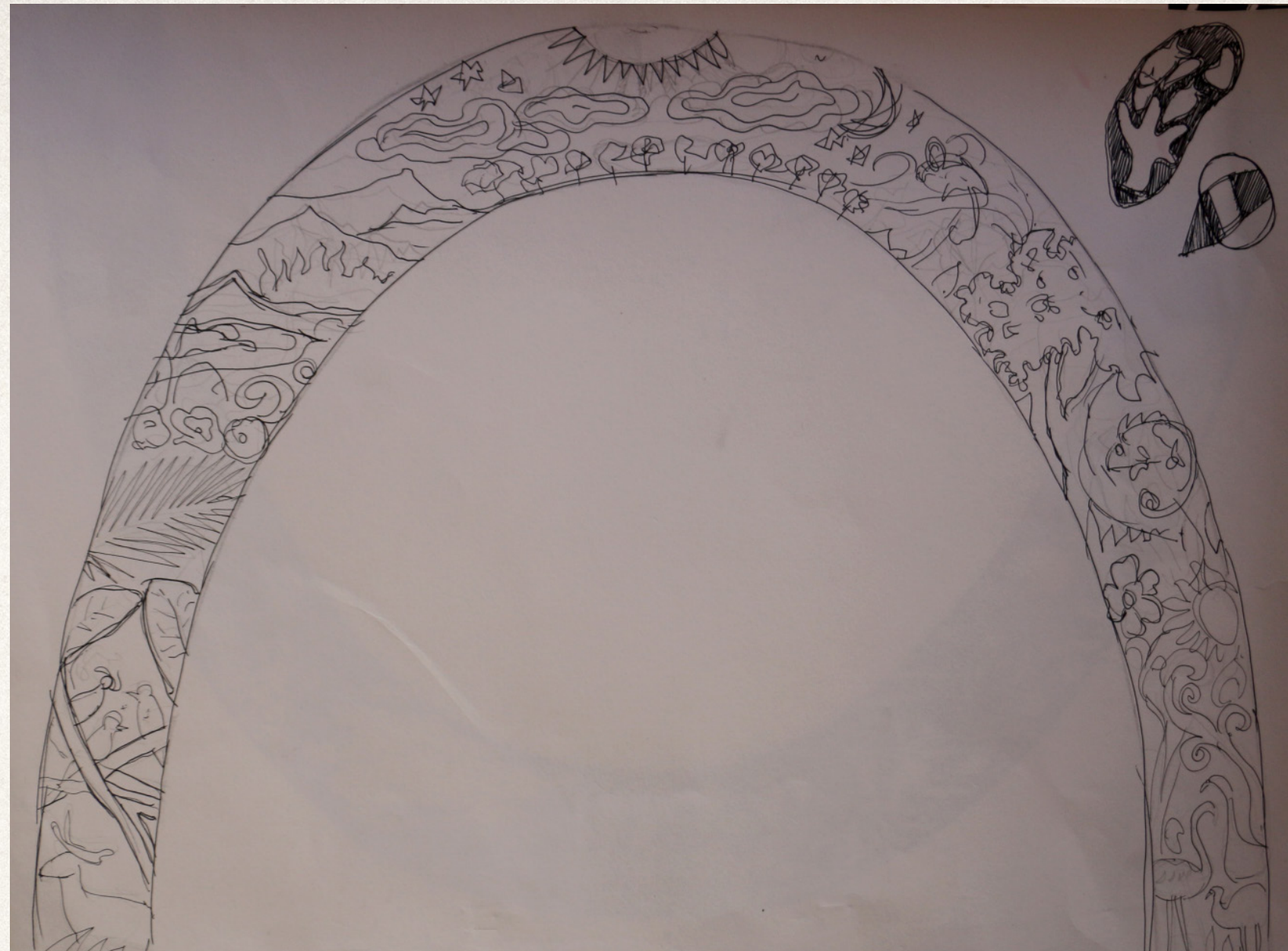

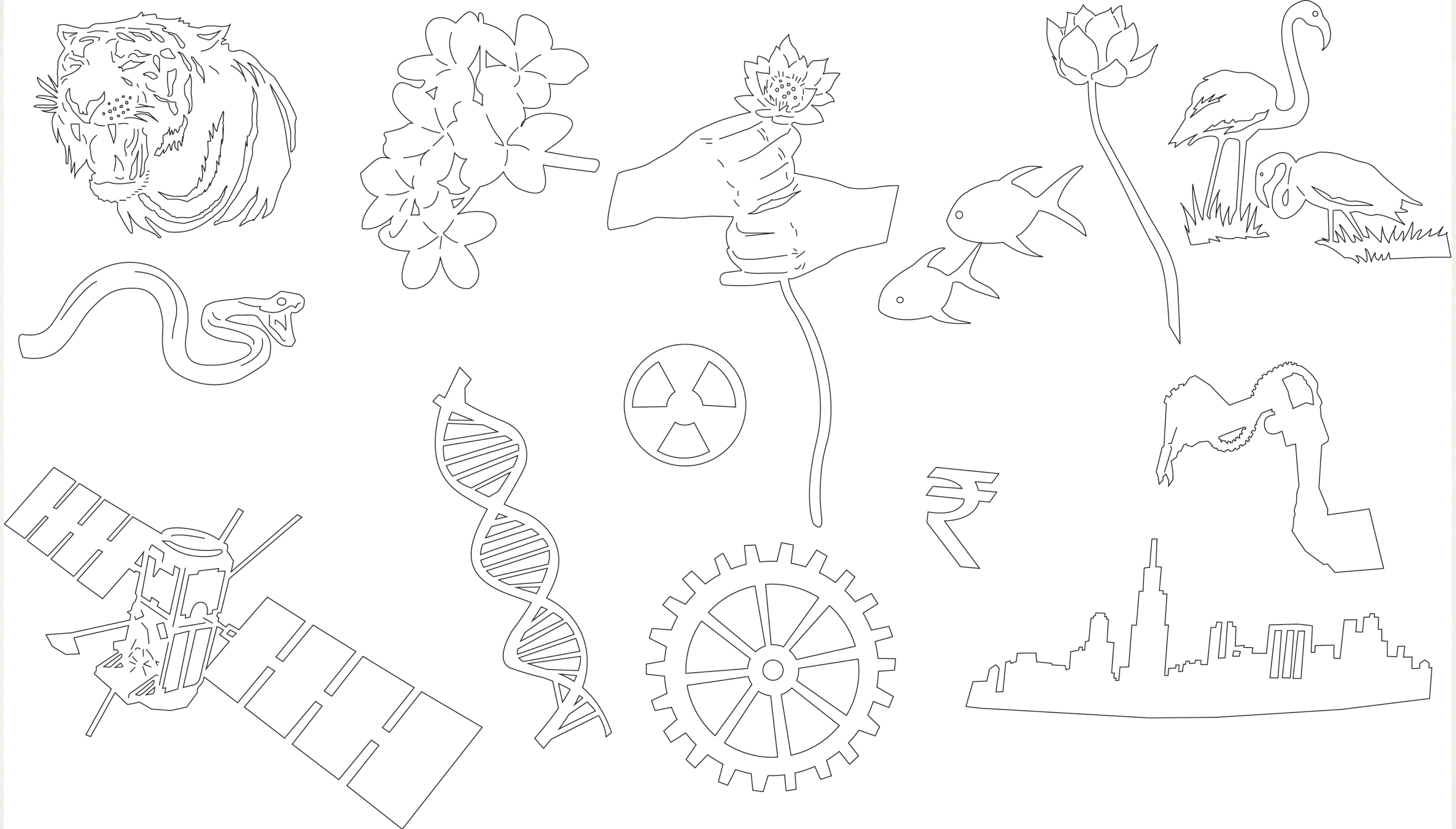



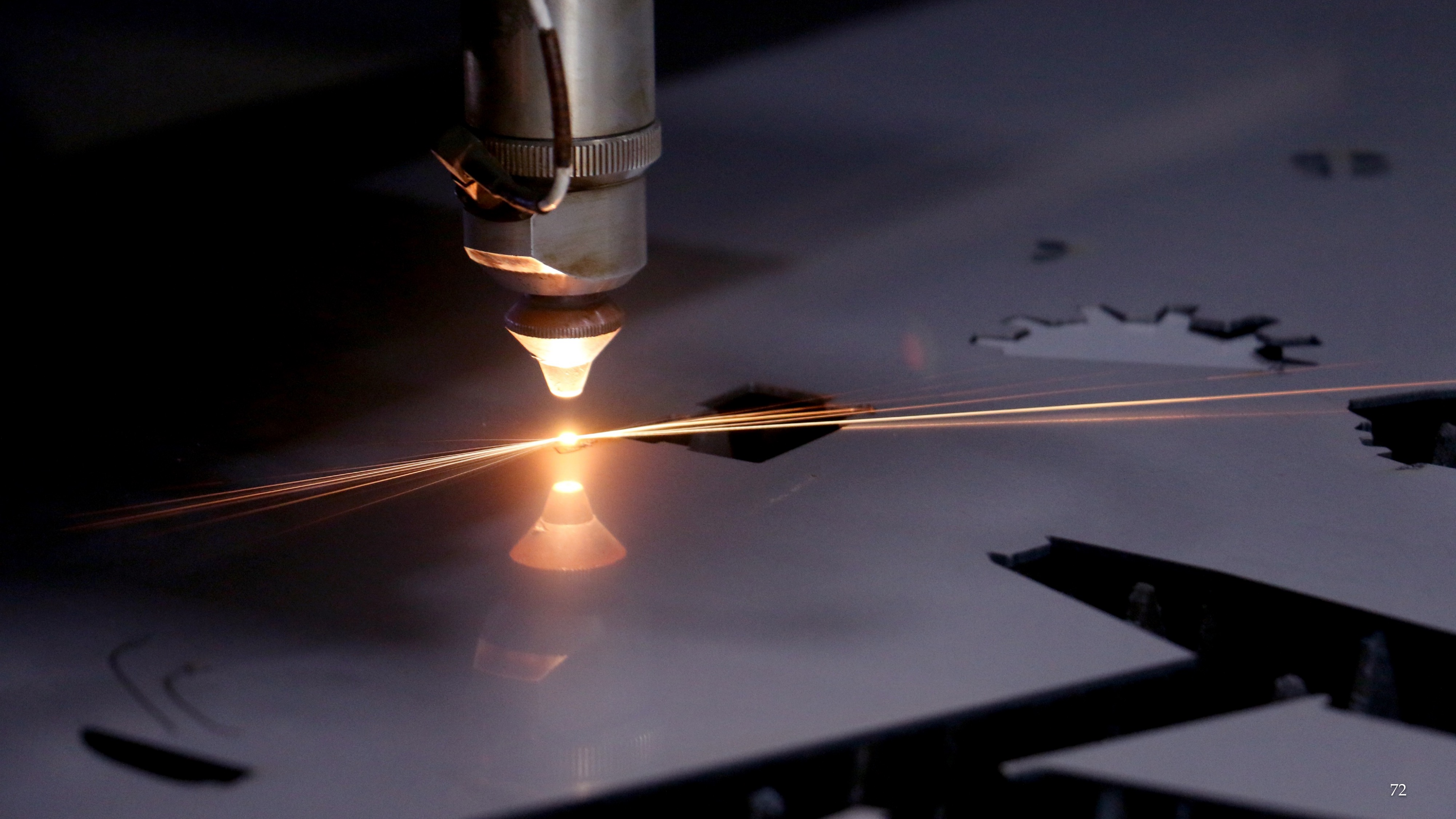

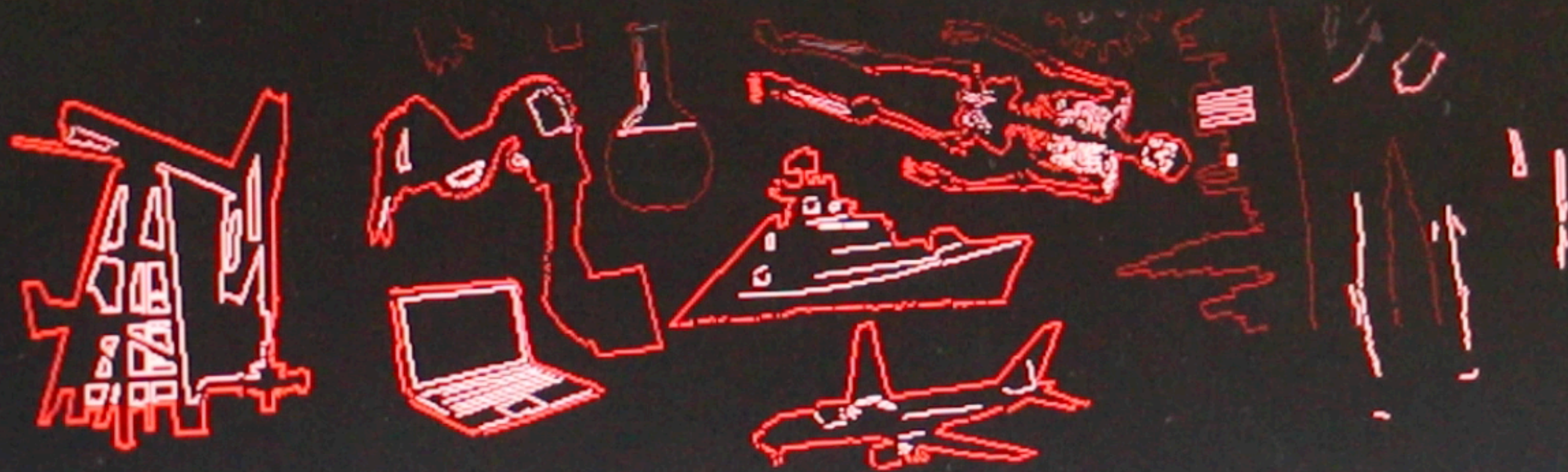

Foundation



IDC School of Design
अभिकल्प विद्यालय









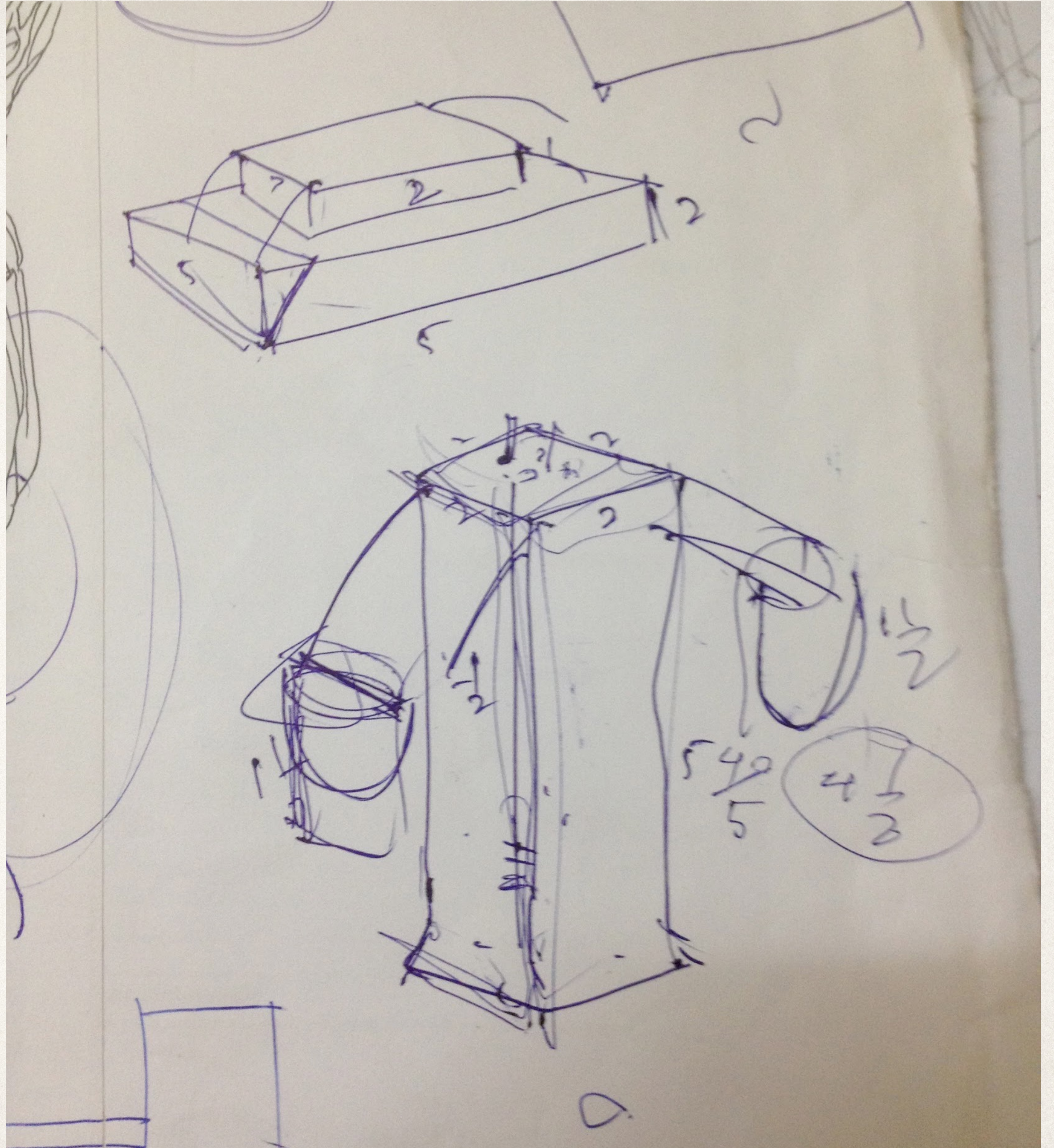
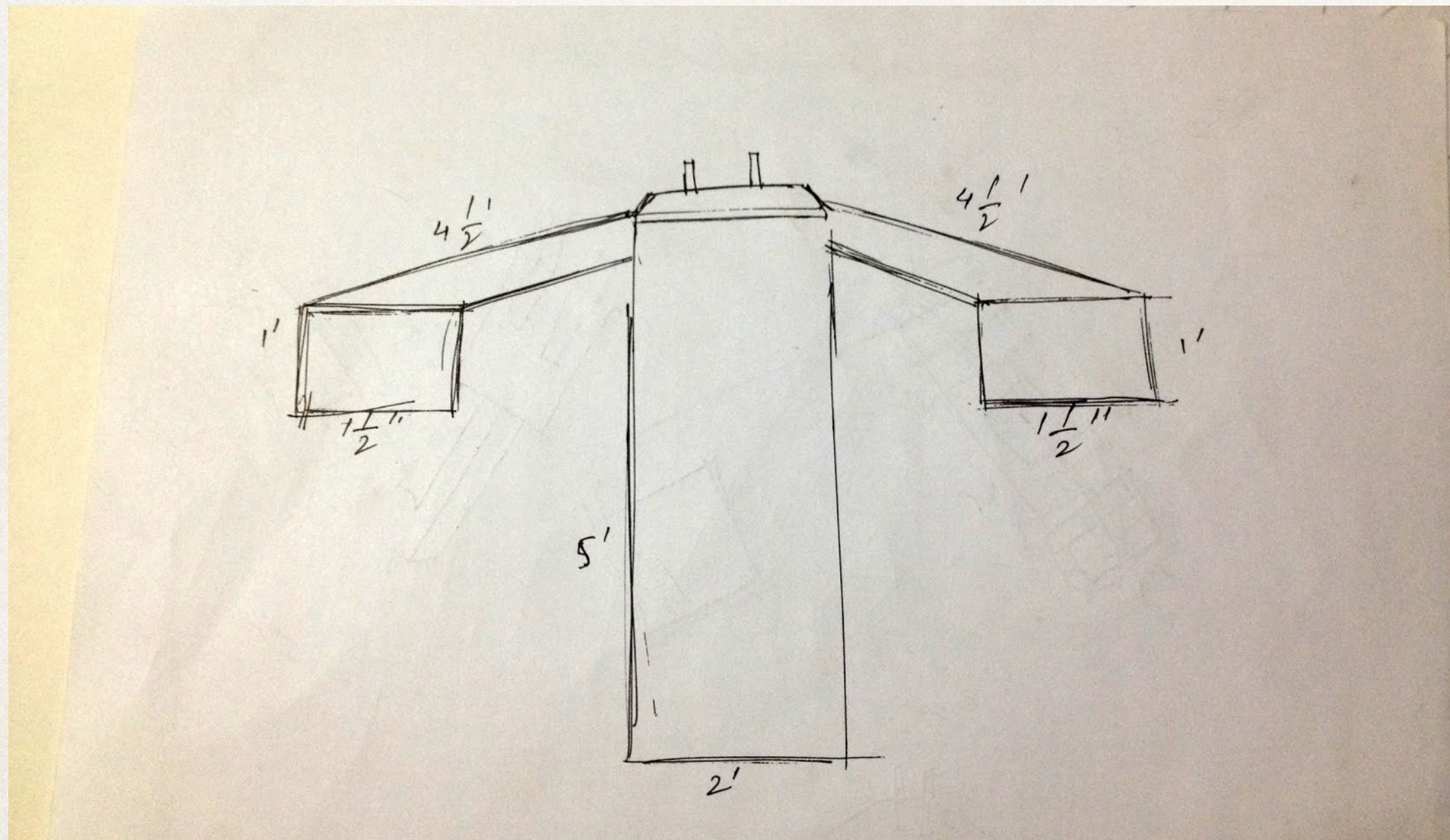
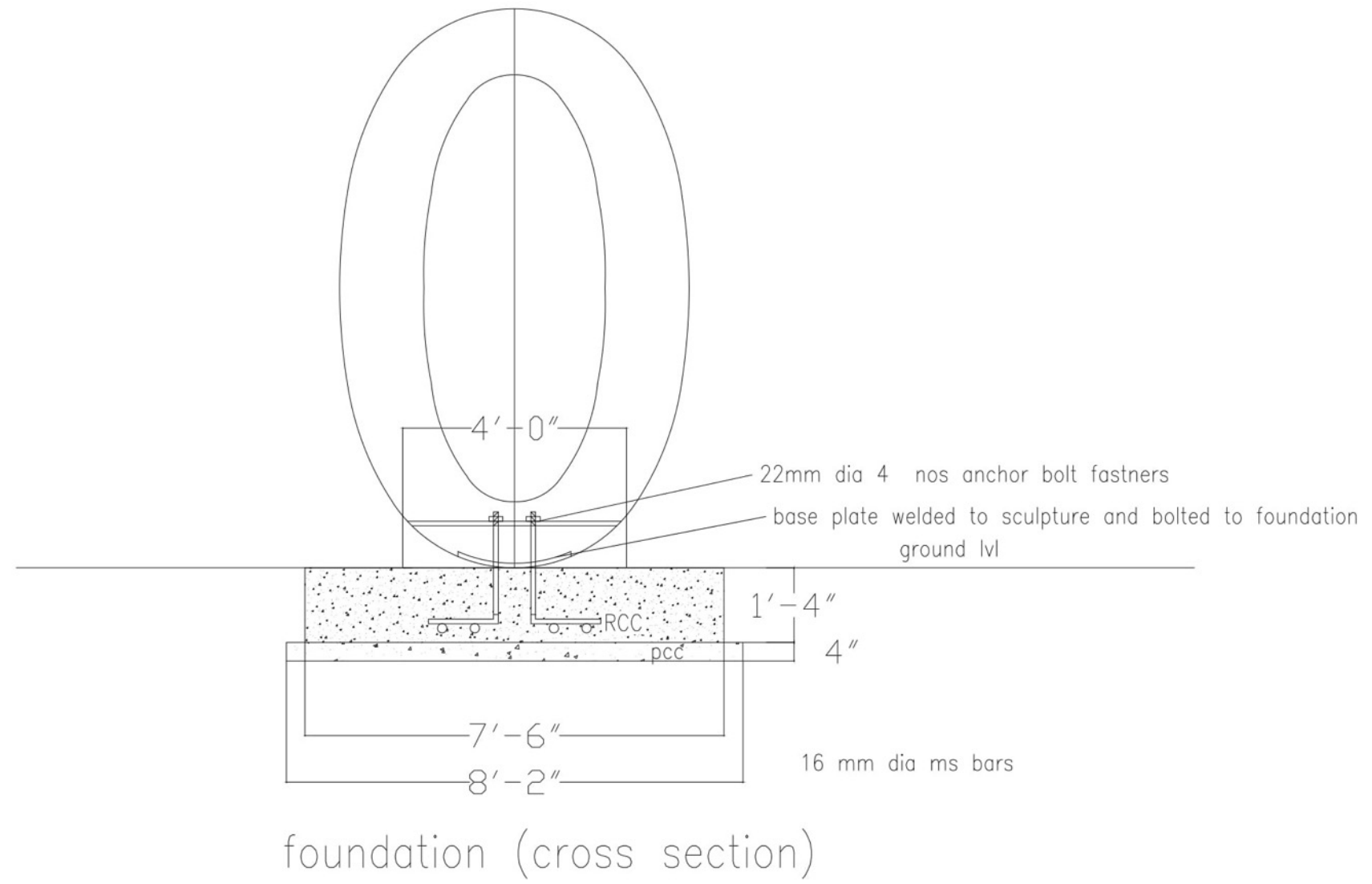





Lets go to the site

Thank You