

Air Transportation System

MODULAR AERIAL VEHICLE

Industrial Design Project III
IDC, IIT Bombay

Minu
176130011

Guide: Prof. P Kumaresan



Industrial Design Centre
Indian Institute of Technology, Bombay

DECLARATION

I declare that this project report submission represents my thoughts in my own way, and where other's ideas or words have been included, I have adequately cited and referenced the original source. This project is all my own work and has not been copied in part or in whole from any other source except where duly acknowledged. As such all use of previously published work (from books ,journals, internet sites etc.) has been cited within the main report and fully referenced as an item in the list of References.

I understand that any violation of the above will be cause for disciplinary action by the institute.

Name - Minu

Roll No - 176130011

Sign - 

APPROVAL SHEET

This Industrial Design project report entitled "Air Transportation System - Modular Aerial Vehicle", by Minu is approved in partial fulfillment of the requirement for Master of Design degree in Industrial Design.

Project Guide - Prof. P Kumaresan



Chair Person -

Airban Guba

Internal Examiner -



External examiner -

Jayesh Sawant

ACKNOWLEDGEMENT

I would like to express my gratitude to my guide, Prof. P Kumaresan for his meticulous guidance and the efforts he put in to make this project happen. His suggestions and instructions were what helped me to steer this project in the right direction and push myself to try and come up with new ideas.

I would also like to thank all the jury members for their valuable inputs and suggestions on this project.

I take this opportunity to thank all the people who provided much-needed information and insights during the research phase of the project.

I thank my family and friends for their support and guidance.



CONTENTS

Introduction	1
Modular vehicle	
History of Unmanned Aerial Vehicle	
History of manned drone attempts	
Parallel Products	9
Study	11
Aerodynamics	
Streamlining in Aerodynamics	
Flight Dynamics of Quadcopter	
Tilt Rotor	
Why Larger Drone?	18
Design Brief	19
Design Brief	
Target Audience	
Ideation	20
Paper Models	28
Sketches	30
Concepts	32
Concept Evaluation	
Concept Evaluation Result	

CONTENTS

Final Concept	37
3D Modelling	40-44
Main chassis	
Battery Pack Specifications	
Interior	
Model Making	45
Mechanism	48
Doors	
Entry Seats	
Folding Propellers and Arms	
Dimensions	50
Modular Vehicle Platforms	51
Branding	52
Final Product	53
Significance of Color	58
Reference	59

ABSTRACT

In the early 20th century personal cars were gradually becoming a popular form of transport. In 1903 the Wright Brothers achieved the first powered flight. Within a decade, dreams of a building a flying car began to crystallize for those in the auto industry.

Large cities with traffic congestion problems are stepping forward to offer their cooperation to drone aviation innovators. A lot of manufacturers seek to put autonomous drones into the air. These drones will just happen to have a, presumably, untrained passenger. Passenger drones, by contrast, would operate autonomously and leave the “roadable” part behind in favor of larger versions of aircraft that already exist.

Modularity in vehicle design has started to gain popularity due to large number of benefits including the possibility to use different types of bodies.

The purpose of this project is to develop a modular aerial platform which is easy to manufacture, easy to operate, light in weight and is battery driven. The key idea is to have a common chassis which could be used by companies to transform the body of the aircraft as per specific need.

01

Introduction

INTRODUCTION

MODULAR VEHICLE

Vehicles used to be built on more unique chassis and subframe sets, the continually expanding ranges of vehicles from all manufacturers have required the introduction of a more versatile solution.

That solution is one modular system of shared platforms that provides the basis or 'architecture' for a number of models.

A modular vehicle is one in which substantial components of the vehicle are interchangeable. This modularity is intended to make repairs and maintenance easier, or to allow the vehicle to be reconfigured to suit different functions.

In a modular electric vehicle, the power system, wheels and suspension can be contained in a single module or chassis. When the batteries need recharging, the vehicle's body is lifted off and placed onto a fresh power module. By using this Modular Vehicle system, the vehicle's batteries do not have to be removed or reinstalled, and their connections remain intact. Other applications of the modular vehicle is discussed in "".

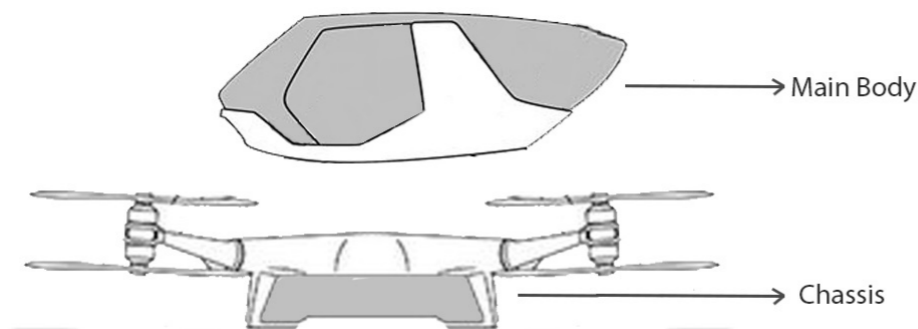

Image 1 : Modular Vehicle with two main modules (chassis and main body)

HISTORY OF UNMANNED AERIAL VEHICLE

The first major milestone in the history of the development of the drone came in 1782 in the form of the invention of the Montgolfier-style - Unmanned Hot Air Balloon.

" Drone" simply refers to any aerial vehicle that is unmanned. By this definition, the earliest unmanned aerial vehicle in the history of drones was seen in 1839, when Austrian soldiers attacked the city of Venice with unmanned balloons filled with explosives. Some of these Austrian Balloons were successful, but a number of them blew back and bombed the Austrians' own lines, so the practice did not become widely adopted.

Image 2: A brief history of drones

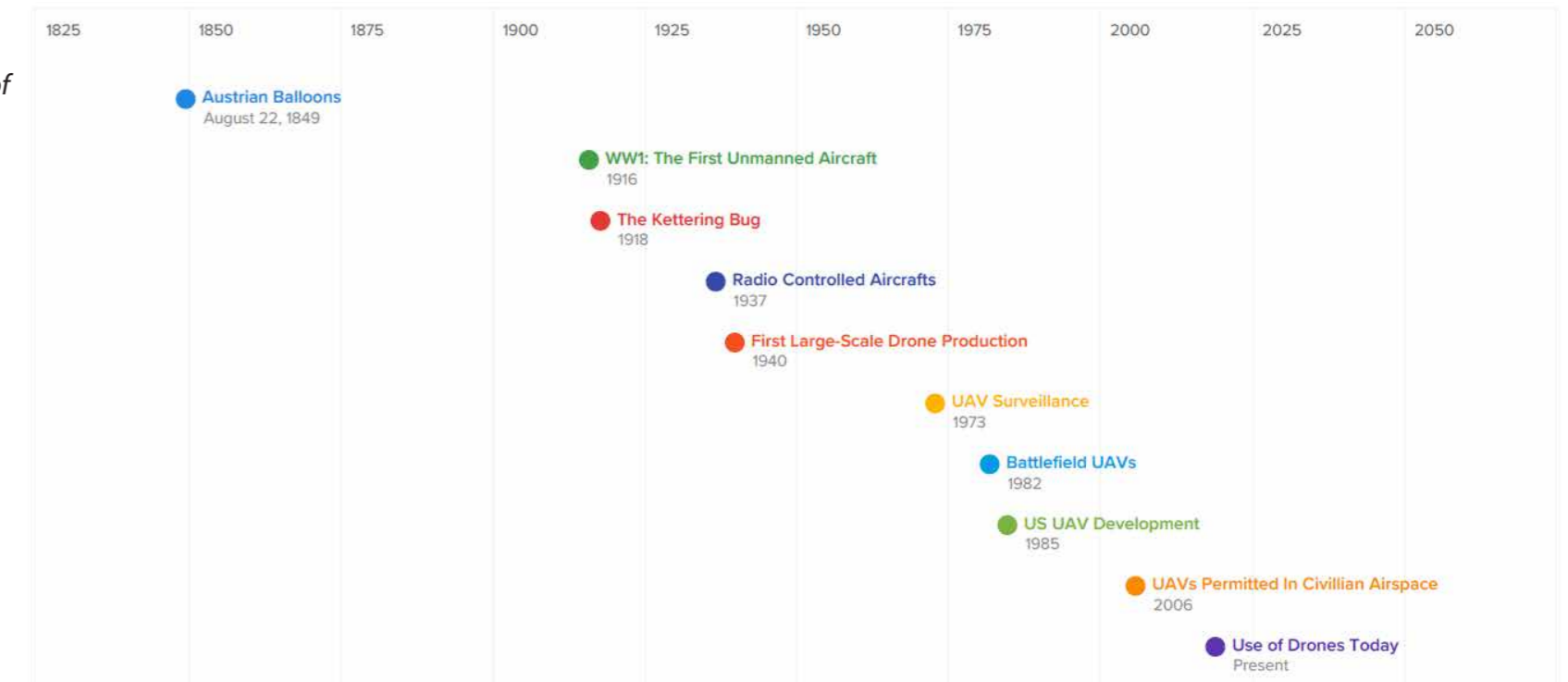
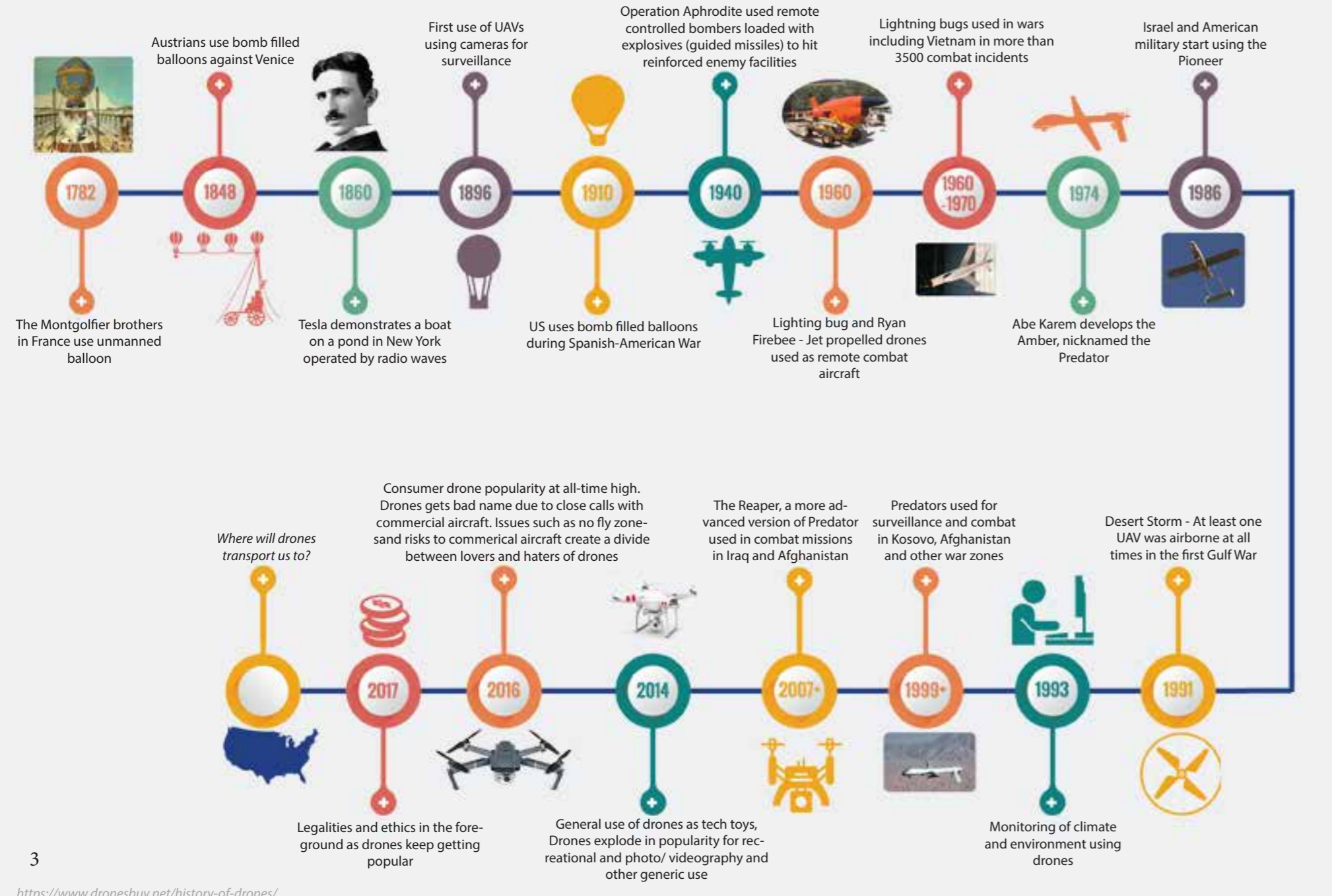

Image 3 : A brief summary of the history of drones – Timeline Infographic



HISTORY OF MANNED DRONE ATTEMPTS

Breguet-Richet Gyroplane No.1, 1907

Quadcopters are almost as old as manned flight itself. The idea of a helicopter is even an ancient one, with people like Da Vinci conceptualizing them in drawings long before it was remotely feasible. The first ever quadcopter was probably built in 1907 by the French Breguet brothers, Jacques and Louis.

It was known as the **Gyroplane No. 1**, could accommodate one person, and had a gross weight of 1274 lbs. It was powered by a 46hp engine and flew at two feet above the ground for at most one minute. the quadcopter design was unstable. At the time it wasn't quite clear how exactly the quadcopter would be controlled. It was neither controllable nor steerable, but it was the first time that a rotary-wing device had lifted itself and a pilot into the air.

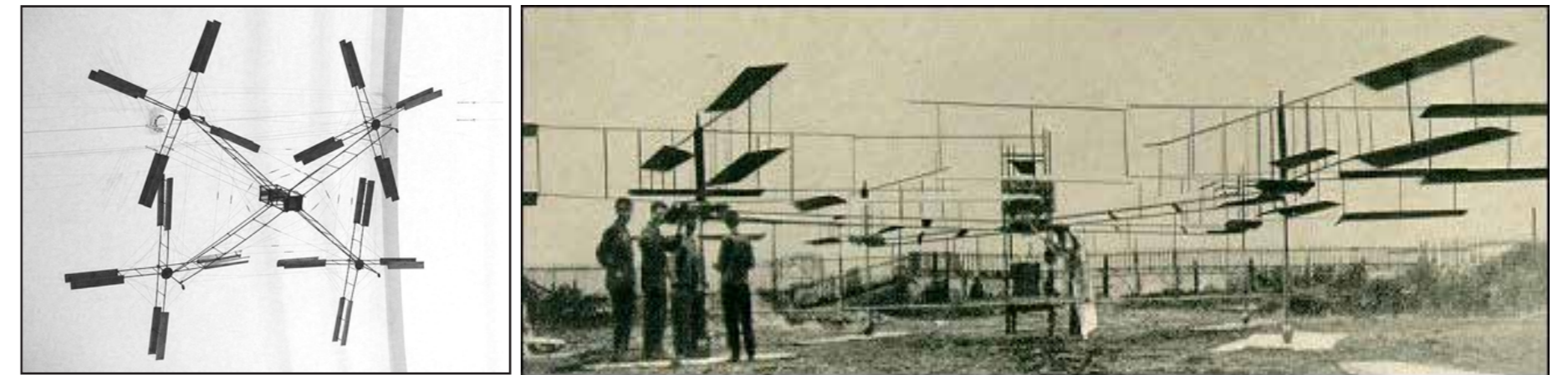

Image 4 : Breguet-Richet Gyroplane No.1

Oehmichen No.2, November 1922

Etienne Oemichen, a young engineer with the Peugeot motor car company, began to experiment with rotating-wing designs in 1920, and in all designed and built six different vertical take-off machines. When the first of these failed to develop enough lift from its twin rotors and 25hp engine to rise off the ground, he added a hydrogen-filled balloon on top of it to give it added stability and lift.

The most noteworthy - and most striking - of his aircraft was the **Oehmichen No.2** which had no less than 4 rotors and 8 propellers, all driven by a single 120hp Le Rhone rotary engine when it flew for the first time on 11 November 1922.

An improved helicopter featuring small vertically mounted rotors which rotated in the opposite direction from the large lifting rotors, probably creating the first reliable flying helicopter capable of carrying a person. This work later led to the development of the tail rotor.

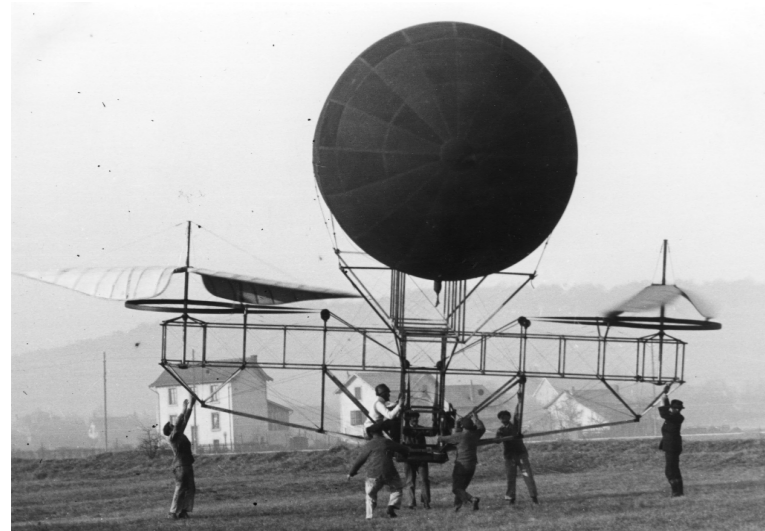

Image 5(a) : Oemichen No.1

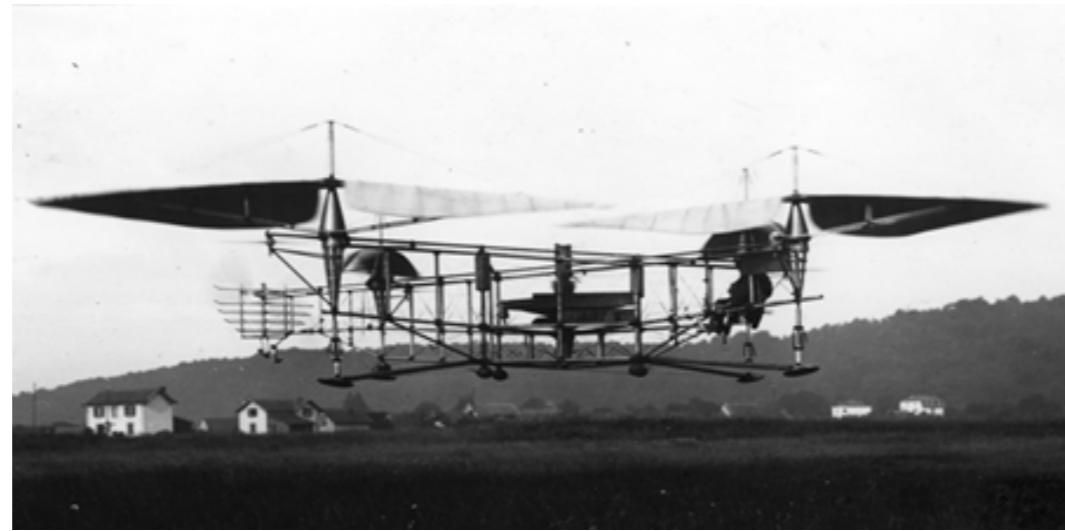

Image 5(b) : Oemichen No.2

De Bothezat helicopter Dec 1922

In January 1921, the US Army Air Corps awarded a contract to Dr. George de Bothezat and Ivan Jerome to develop a vertical flight machine. The 1678kg "X"-shaped structure supported a 8.1m diameter six-blade rotor at each end of the 9m arms. At the ends of the lateral arms, two small propellers with variable pitch were used for thrusting and yaw control.

The helicopter had four six-bladed rotors mounted at the ends of beams 20 metres in length, forming a cross and intersecting in all directions. The rotor axes were not parallel but slightly inclined inwards so that if prolonged they would have met at a point directly above the centre of gravity. Besides the rotors with variable-pitch blades, the helicopter had two horizontal propellers called 'steering airscrews' as well as two small airscrews placed above the gearbox and acting as regulators for the 220hp engine.

Although its four massive six-bladed rotors allowed the craft to successfully fly, it suffered from complexity, control difficulties, and high pilot workload, and was reportedly only capable of forward flight in a favorable wind.

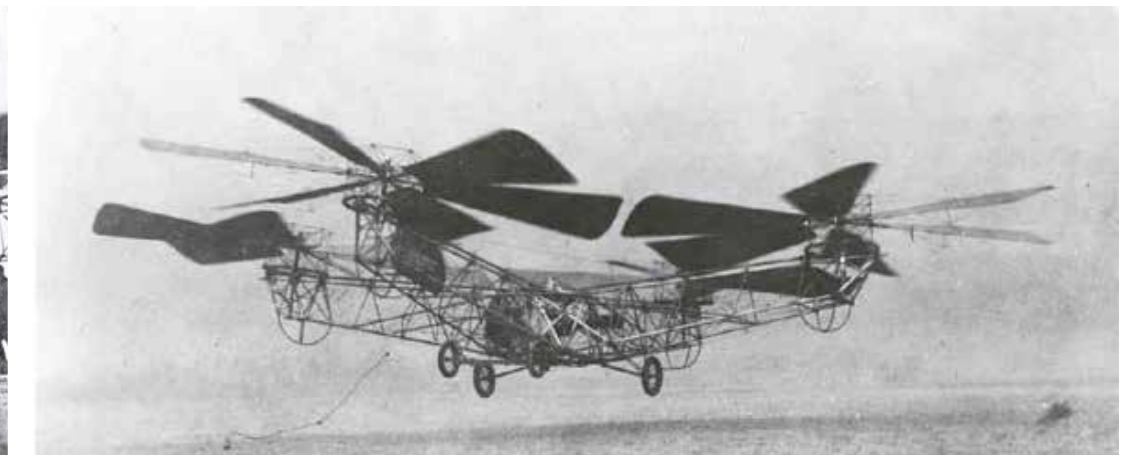

Image 6 : De Bothezat Helicopter

Convertawings Model A, 1956

Convertawings has revived the concept tried out in 1922 in France by Oemichen, lift for whose helicopter was provided by four rotors. The four rotors of this helicopter are mounted laterally on outriggers in two tandem pairs. The control mechanism is extremely simplified and obtained by differential change of thrust between the rotors. Power is provided by two engines connected to the rotor drive system by multiple vee belts. Shafting and transmission cases ensure inter-connection between the four rotors, so that at need either engine can drive all of them.

Due to a lack of orders for commercial or military versions however, the project was terminated.

This helicopter proved the quadrotor design and it was also the first four-rotor helicopter to demonstrate successful forward flight.

The first flights took place in March 1956.

It was the first to use propulsion, or a propeller's forward thrust, to control an aircraft's roll, pitch and yaw.



Image 7(a) : Convertawings with crew

https://www.cradleofaviation.org/history/exhibits/exhibit-galleries/the_jet_age/convertawings_model_a_quadrotor.html

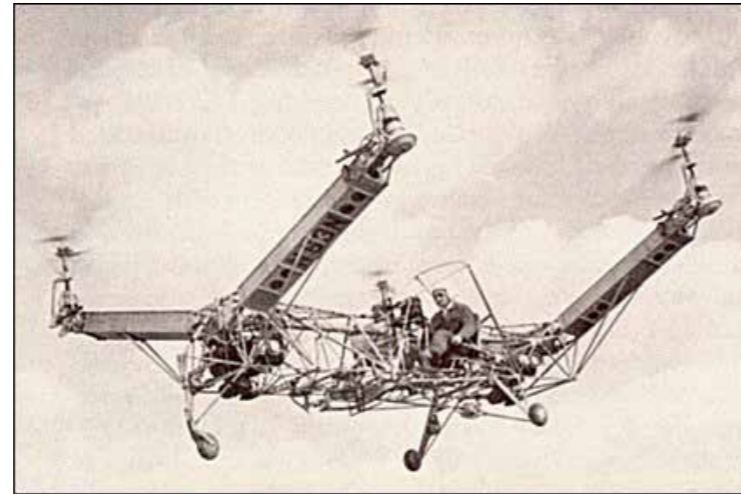

Image 7(b) : Convertawings Model A

https://www.cradleofaviation.org/history/exhibits/exhibit-galleries/the_jet_age/convertawings_model_a_quadrotor.html

Curtiss Wright VZ-7. 1958

The VZ-7 was of exceedingly simple design, essentially consisting of a rectangular central airframe to which four vertically-mounted propellers were attached in a square pattern. The central fuselage carried the pilot's seat, flight controls, fuel and lubricant tanks, and the craft's single shaft turbine engine. There were four propellers in total. The VZ-7 was controlled by changing the thrust of each propeller. The flying platform was maneuverable and easy to fly.

Two prototypes were delivered to the US Army in mid-1958.

The VZ-7's control system was also very simple; directional movement was controlled by varying the thrust of each individual propeller, with additional yaw control provided by moveable vanes fixed over the engine exhaust. The craft were capable of hovering and forward flight and proved relatively stable and easy to operate.

The aircraft performed well during tests, but was not able to meet the Army's standards, therefore it was retired and returned to the manufacturer in 1960.



Image 8(a) and 8(b): Two prototypes of Curtiss Wright VZ-7. 1958

<http://www.radicalrc.com/blog/wp-content/uploads/2012/12/CurtisWrightAirGeep.bmp>

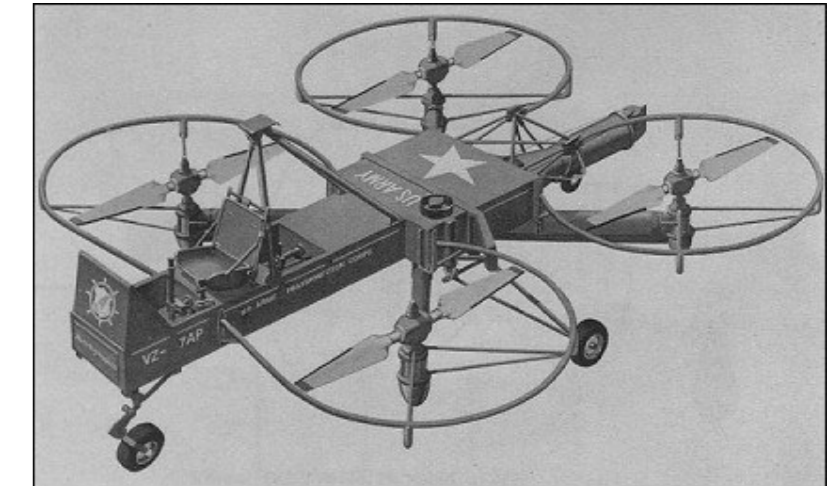

http://www.aviastar.org/helicopters_eng/curtiss_vz-7.php

02

Parallel Products

Ehang - Ehang 184, Ehang 216

Ehang184, the Autonomous Aerial Vehicle (AAV) from Ehang, is a one-person passenger drone. It is completely autonomous and is powered by electricity only. It has completed more than 1,000 test flights with and without passengers, reported the CNN. The aim of this flying taxi is to provide short distance communication and transportation solution. [Ref 16]



Image 9 : Ehang 184

<http://tvi.com.pk/chinese-company-unveils-self-driving-flying-vehicle/>

Workhorse - Surefly

The SureFly is a two-seat hybrid eVTOL vehicle designed by American truck-maker Workhorse Group. It features a gas combustion engine generating electricity and a parallel battery pack offering a redundant backup power source. [Ref 17]



Image 10: Surefly

<https://www.helis.com/database/news/workhorse-surefly-unit/>

Airbus – Airbus CityAirbus

The Airbus CityAirbus is a multinational project by Airbus Helicopters to produce an electrically-powered VTOL aircraft demonstrator. It is intended for the air taxi role, to avoid ground traffic congestion. [Ref 19]



Image 11: Airbus CityAirbus

<https://www.smartmeetings.com/news/108691/airbus-flying-taxis-division>

Airbus - A³ Vahana

The Airbus A³ Vahana is an electric-powered vertical take-off and landing 8-prop flying prototype. Vahana is a single-passenger air taxi that draws on advances in electric motors, machine vision, and AI. [Ref 18]



Image 12: Vahana

<https://www.wired.com/story/airbus-vahana-first-flight-faa-certification-flying-cars/>

Airbus – Pop Up

Airbus' Pop.Up essentially is a capsule that can either connect to a ground or air module. The project also says it can be integrated into other means of transportation. Artificial Intelligence (AI) takes care of managing trips, freeing passengers to interact and choose from a multimodal transportation system or relax and enjoy the journey in this self-piloted autonomous system that can ride on the ground or fly in the air. [Ref 19]



Image 13: Pop.Up

<https://ihc2015.info/skin/airbus-max.akp>

Bell - Bell Nexus eVTOL

With its massive 90-degree 6 tilting rotors, it houses 4 passengers and a pilot cockpit. It is powered by a hybrid-electric propulsion system using a turbine. One battery pack sits on top of the aircraft in front of the turbine, and another pack below the aircraft frame. The Nexus will use Bell's lift concept, with the 6 tilting ducted fans designed to be safe, redundant, and fairly quiet for air travel. [Ref 20]



Image 14: Nexus eVTOL

<https://www.bellflight.com/company/innovation/nexus>

03

Study

Aerodynamics

Forces acting on flying body.

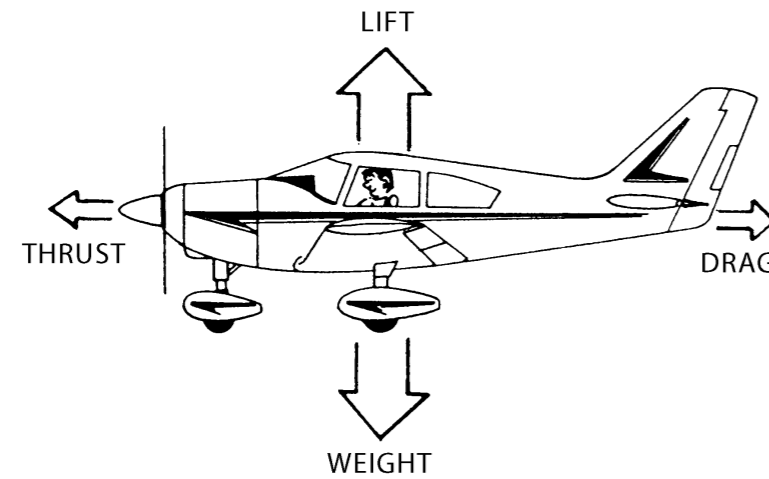

Image 15: Forces acting on an aircraft in air

<http://learntoflyblog.com/2014/09/15/learn-to-fly-5-the-four-forces-part-1/>

Thrust is a force that moves an aircraft in the direction of the motion. It is created with a propeller, jet engine, or rocket. Air is pulled in and then pushed out in an opposite direction.

Drag is the force that acts opposite to the direction of motion. It tends to slow an object. Drag is caused by friction and differences in air pressure. An example is putting your hand out of a moving car window and feeling it pull back.

Weight is the force caused by gravity.

Lift is the force that holds an airplane in the air. The wings create most of the lift used by airplanes.

The way the four forces act on the airplane make the plane do different things. Each force has an opposite force that works against it. Lift works opposite of weight. Thrust works opposite of drag. When the forces are balanced, a plane flies in a level direction. The plane goes up if the forces of lift and thrust are more than gravity and drag. If gravity and drag are bigger than lift and thrust, the plane goes down. Just as drag holds something back as a response to wind flow, lift pushes something up. The air pressure is higher on the bottom side of a wing, so it is pushed upward. [Ref 21]

Streamlining in Aerodynamics

When an object passes through a fluid (containing particles, of course), the particles move relative and along the object's surface. If the object is shaped in such a way that the particles leave its surface suddenly anywhere, a void is created there. This creates eddy fluid currents which could be very random in terms of magnitude and direction.

Designing the object well rounded up front and slowly tapering it down till the end, prevents the particles of the fluid from leaving the surface as long as possible, thereby reducing the chance of eddies to form. Thus, drag is reduced. [Ref 22]

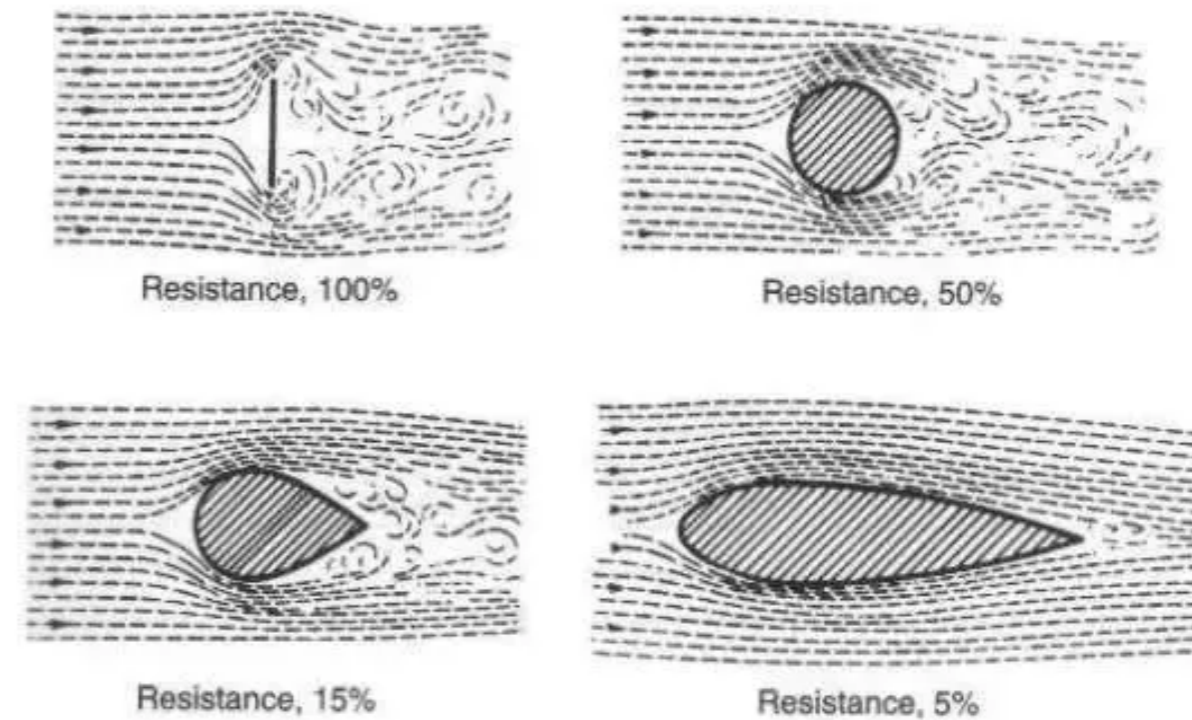

Image 16: Streamlined body and drag resistance

<https://www.quora.com/How-does-a-streamlined-body-reduce-drag>

Streamlining in Aerodynamics

Skin friction drag and Form friction drag

Skin drag: caused due to viscosity of fluid.

When body comes in contact with the fluid (air), the fluid layer comes in contact and applies a resistance on the body in the flow direction.

Form drag: caused due to form of the body.

At some point over the surface of the body, viscous forces overcome the inertial force and the fluids separates from the body.

The separated fluid moves away from the body which creates a region behind the body, where the fluid pressure is low. The region is called wake region. Now the body is subjected to a pressure differential in the flow, in front of it is the fluid with high pressure and behind it the fluid with low pressure. The pressure differences forces also try to push the body in the direction of the flow.

Streamlining form can help reduce form drag by delaying separation over the length of the body. Streamlining doesn't affect skin-friction drag much, it can increase it, but the trade-off is almost in the favor of reducing the Form drag.

Form drag is mostly higher than the skin drag.

Streamlining form can help reduce form drag by delaying separation over the length of the body.

Streamlining doesn't affect skin friction drag much, it can increase it, but the trade-off is almost in the favor of reducing the Form drag.

Flight Dynamics of Quadcopter

Each rotor produces both a thrust and torque about its center of rotation, as well as a drag force opposite to the vehicle's direction of flight. In this configuration, the rotors 2 and 4 are rotating counterclockwise and the rotors 1 and 3 are rotating clockwise. With the two sets of rotors rotating in opposite directions, the total angular momentum is zero. Thus, if there is no torque on the system (the system here being the drone), then the total angular momentum must remain constant (zero in this case). [Ref 23]

Rotation:

Let us assign each rotor a value of +2, +2 (rotors 2 and 4), -2, -2 (rotors 1 and 3), which adds up to zero.

In order to rotate the drone to the right. Decrease the angular velocity of rotor 1 such that now it has an angular momentum of -1 instead of -2. If nothing else happened, now the total angular momentum of the drone would be +1, so the drone rotates clockwise so that the body of the drone has an angular momentum of -1, in order to balance angular momentum.

Decreasing the spin of rotor 1 caused the drone to rotate, but it also decreased the thrust from rotor 1. Now the net upward force is not equal to the gravitational force, and the drone descends. The thrust forces aren't balanced, so the drone tips downward in the direction of rotor 1. [Ref 24]

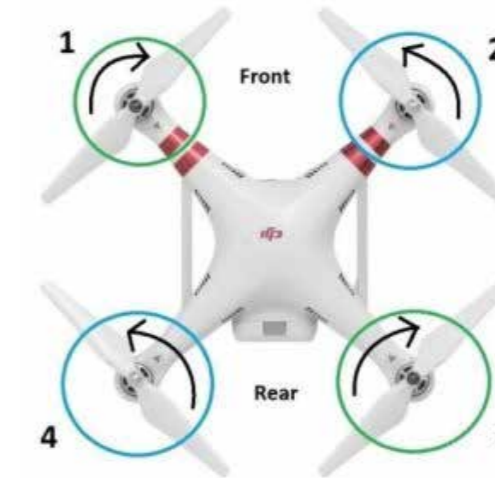

Image 17 Rotational directions on quadcopters

Flight Dynamics of Quadcopter

Blue is clockwise rotation
 Orange is anticlockwise rotation
 Red arrows represent RPM
 Green Arrow points to 'nose' of drone

- RPM on all four rotors is equivalent
- Torque is in equilibrium so there is no YAW (aircraft points forward)



Hovering



Roll

- Increase RPM on one side and/or decrease RPM on opposite side
- Illustration would result in right roll

- Increase the RPM/Torque on the clockwise rotating (blue) motors
- results in LEFT Yaw.

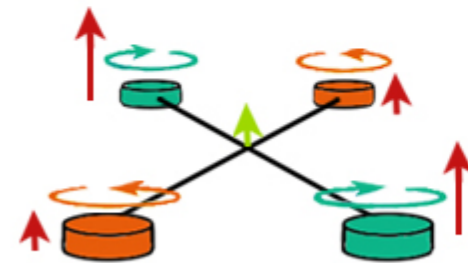

Yaw - Left

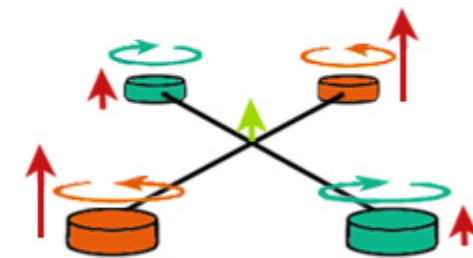

Yaw - Right

- Increase the RPM/Torque on the anti-clockwise rotating (orange) motors

Image 18(a) Flight dynamics of Quadcopter

[Ref 25]

Flight Dynamics of Quadcopter

- Increase altitude by increasing RPM on all four rotors simultaneously



Vertical Ascent

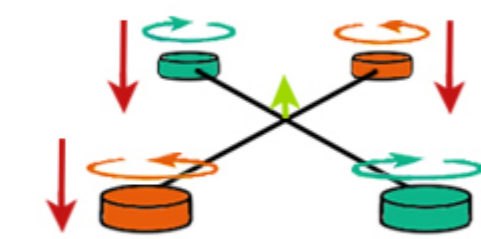

Vertical Descent

- Decrease altitude by decreasing RPM on all four rotors simultaneously

- Increase the RPM on rear motors and/or decrease RPM on front motors

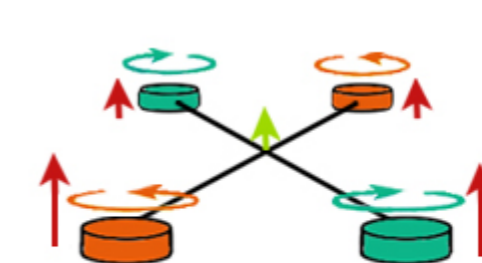

Pitch- Forward

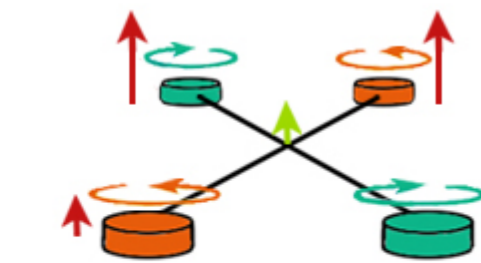

Pitch- AFT

- Increase the RPM on front motors and/or decrease RPM on rear motors

Image 18(b): Flight dynamics of Quadcopter

[Ref 25]

Tilt Rotor

In a tiltrotor aircraft only the rotor pivots rather than the entire wing. Tilt rotor propellers drag the plane forward.

In vertical flight, the tiltrotor uses controls in following manner;

- Yaw is controlled by tilting its rotors in opposite directions.
- Roll is provided through differential power or thrust.
- Pitch is provided through rotor cyclic or nacelle tilt.

Tiltrotors also provide substantially greater cruise altitude capability than helicopters. Tiltrotors can easily reach 6,000 m / 20,000 ft or more whereas helicopters typically do not exceed 3,000 m / 10,000 ft altitude. This feature will mean that some uses that have been commonly considered only for fixed-wing aircraft can now be supported with tiltrotors without need of a runway.

The tiltrotor's advantage is significantly greater speed than a helicopter. [Ref 27]

04 Why Larger Drone?

Why Larger Drone?

Quadcopters are more stable (fitted with electronic stabilization)

Quadcopter's simple design wins over many pilots. They do not come with long shafts, unlike helicopters. These are difficult to align.

Controls are better and easy – lesser the controls - making AI will be easier compared to flight mechanics; Variables will be lesser to automation easier, software faster and more accurate.

05 Design Brief

Design Brief

Developing a modular aerial platform for multipurpose use.

Usefulness:

To solve congestion and on-demand mobility by utilizing 'Urban Airspace'
Modular vehicles to use different types of bodies on one standardized chassis.

Design:

The design gives an overall understanding of a common chassis and its usefulness.
The chassis model will be modular.
A basic idea of the interior.
The design will be multipurpose.

Target Audience

Targeted audience are the logistic/taxi company

06

Ideation

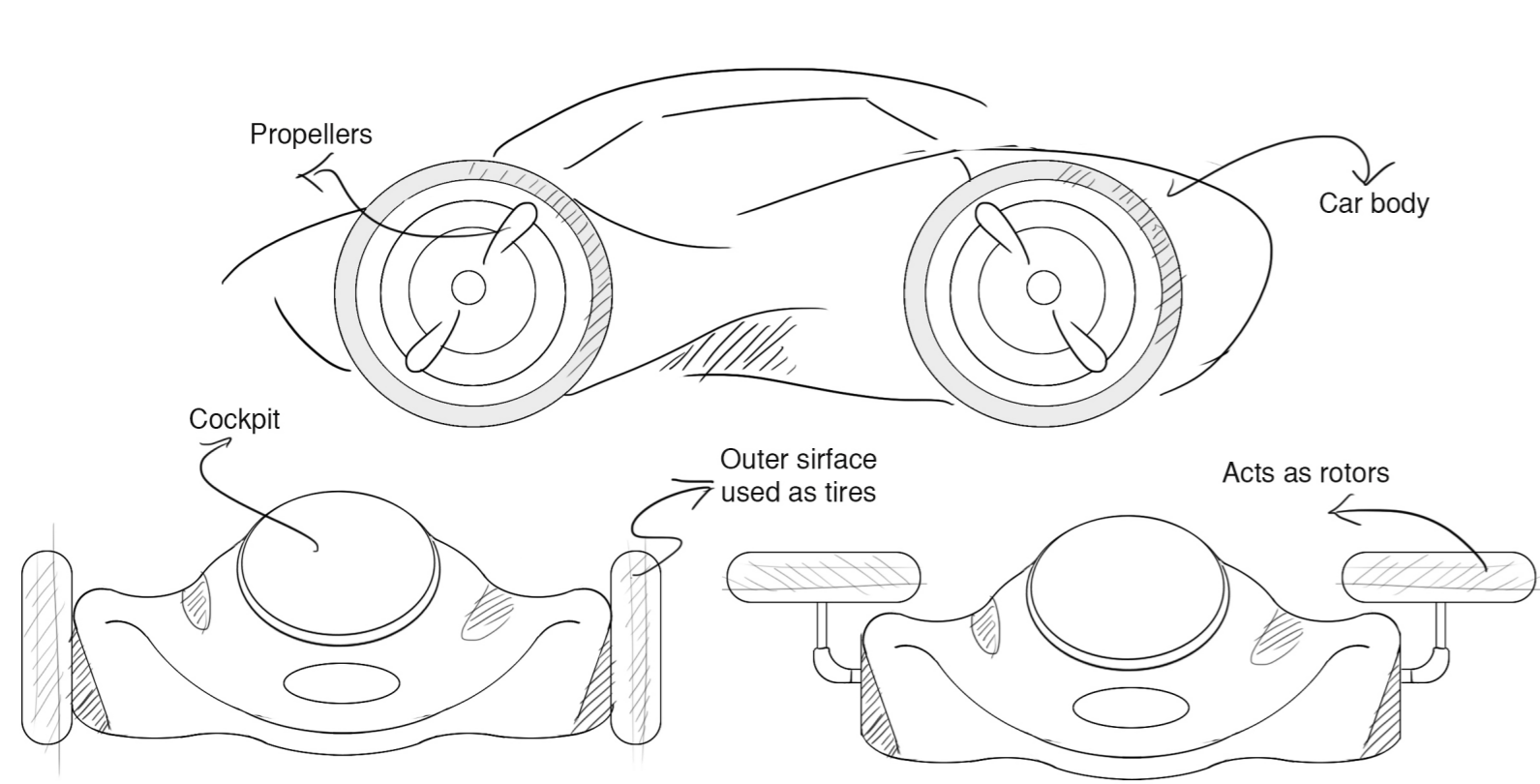

The idea was to have a simple chassis, with propellers embedded in the wheels itself. Thus the whole system will act as a road vehicle as well. It can be transform to a flight mode when needed. Thus the system will be a space saver and lesser space for the bases chassis will be consumed. The body can resemble to a seamless form of a car. The wheels will be slightly larger than the regular wheels of a car.

Image 19: *Idea 1*

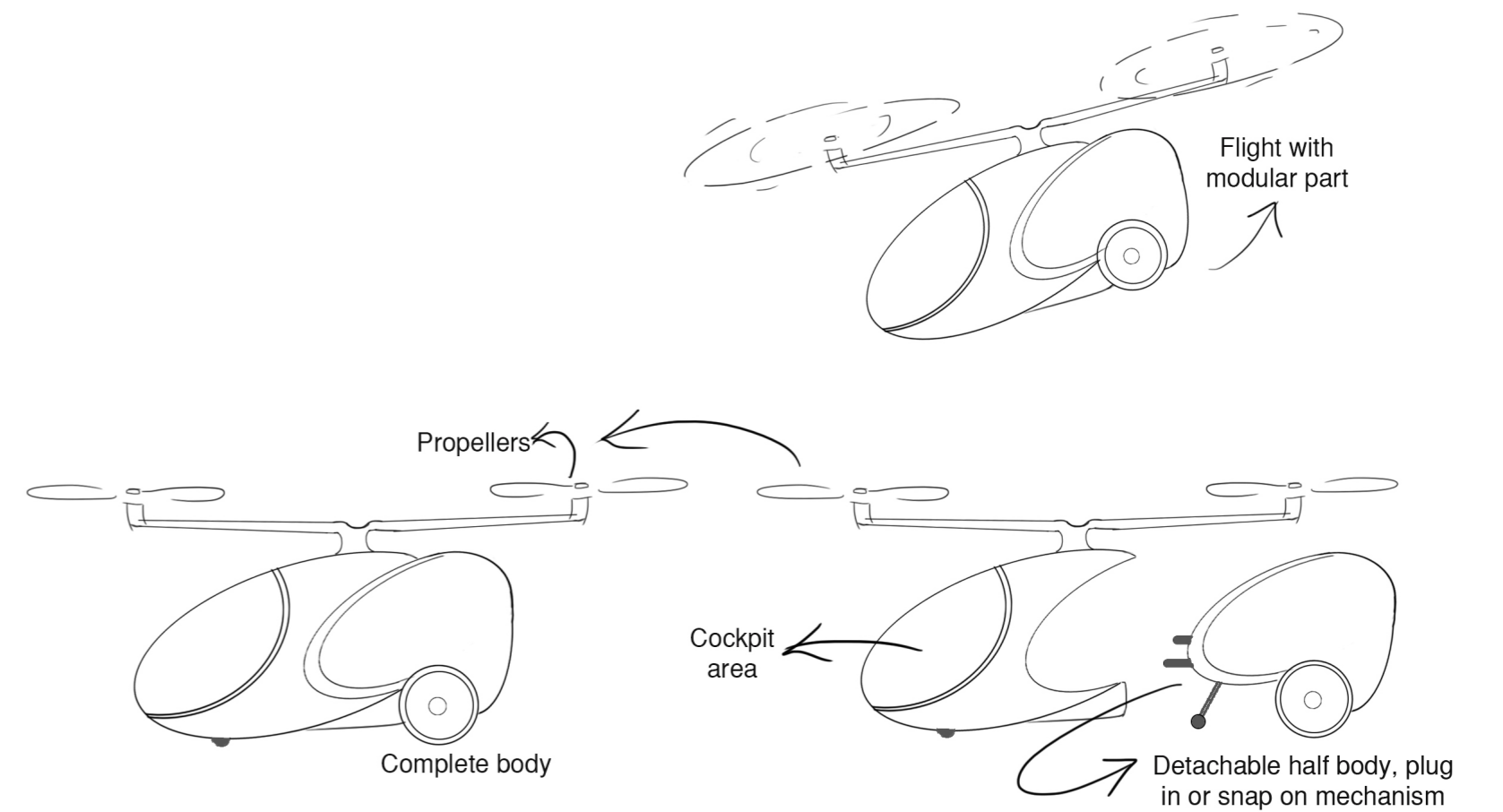

This passenger drone was to have body in two parts, a front and a rear part. The two parts will combine together to form a single unit. The front part is designed in such a way that it has the rotor system on top of it attached. The rear end is detachable and replaceable. It ca be of any form and design. The rear end has a wheel system and landing gear as well, making it easier to remove from the main body.

Image 20: *Ideas 2*

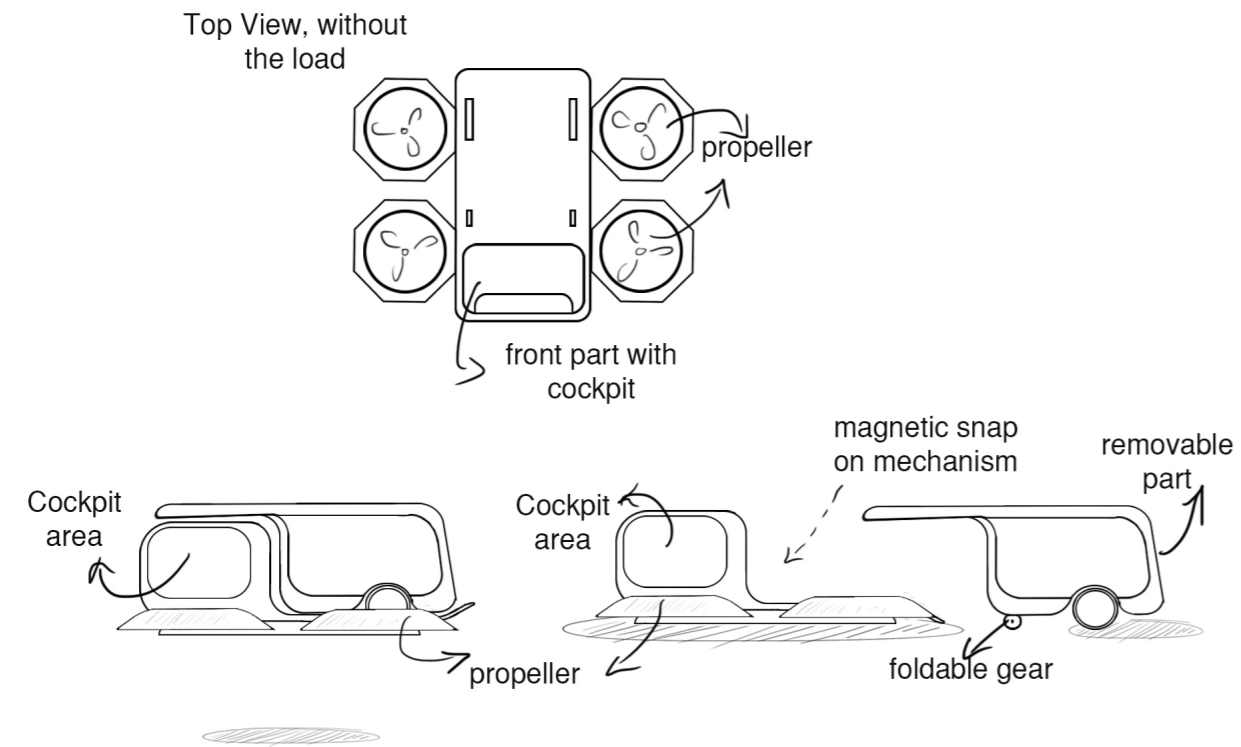

This idea is very similar to the previous one, except the propellers are shifted to the base unit. The base chassis will have the propellers attached to it. The entire base chassis is attached to the cockpit portion of the vehicle. The upper body is divided into two parts. The front part is attached to the base. The rear end is detachable and replaceable. Based on the requirement of the user, the body can be chosen.

Image 21: Ideas 3

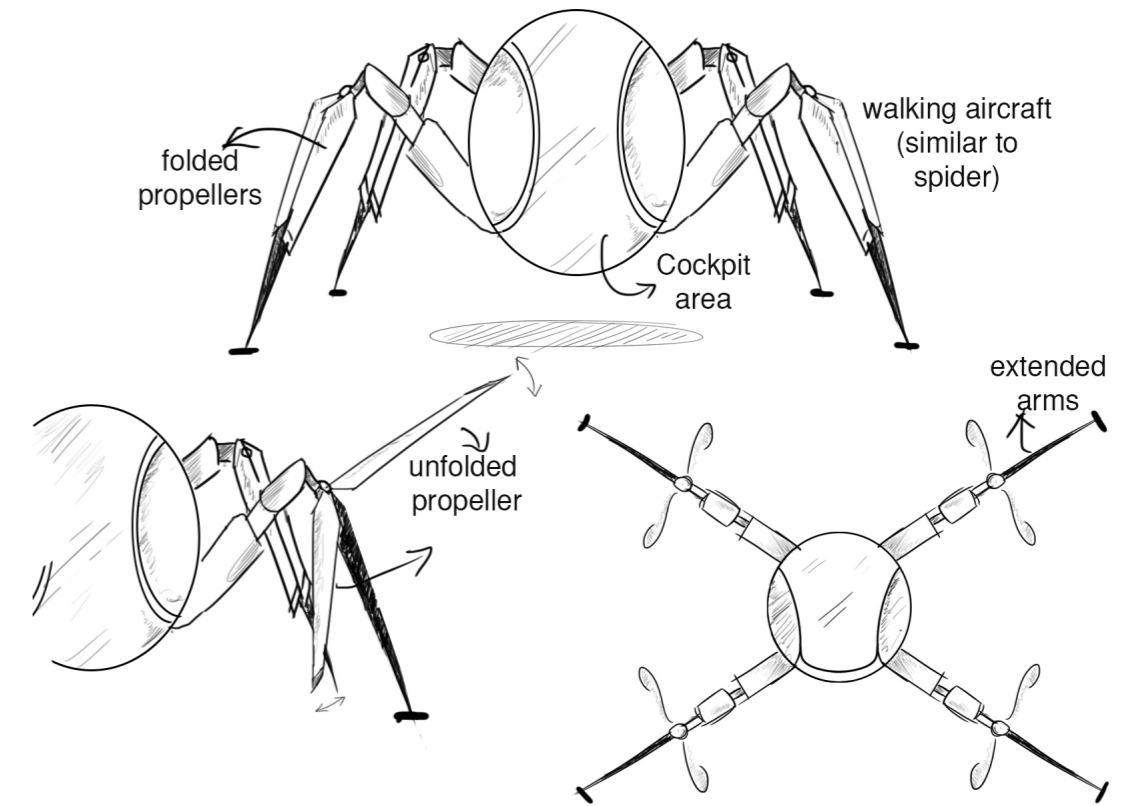

This idea was more of sci-fi design. It has a form inspired from a spider. The legs will be foldable and has foldable propellers. The foldable propellers are designed in such a way that it can be hidden in the arms itself. The cockpit is simple and oval shaped at the center of the four legs. It is a walking drone, and walks like a spider only with four legs.

Image 22: Ideas 4

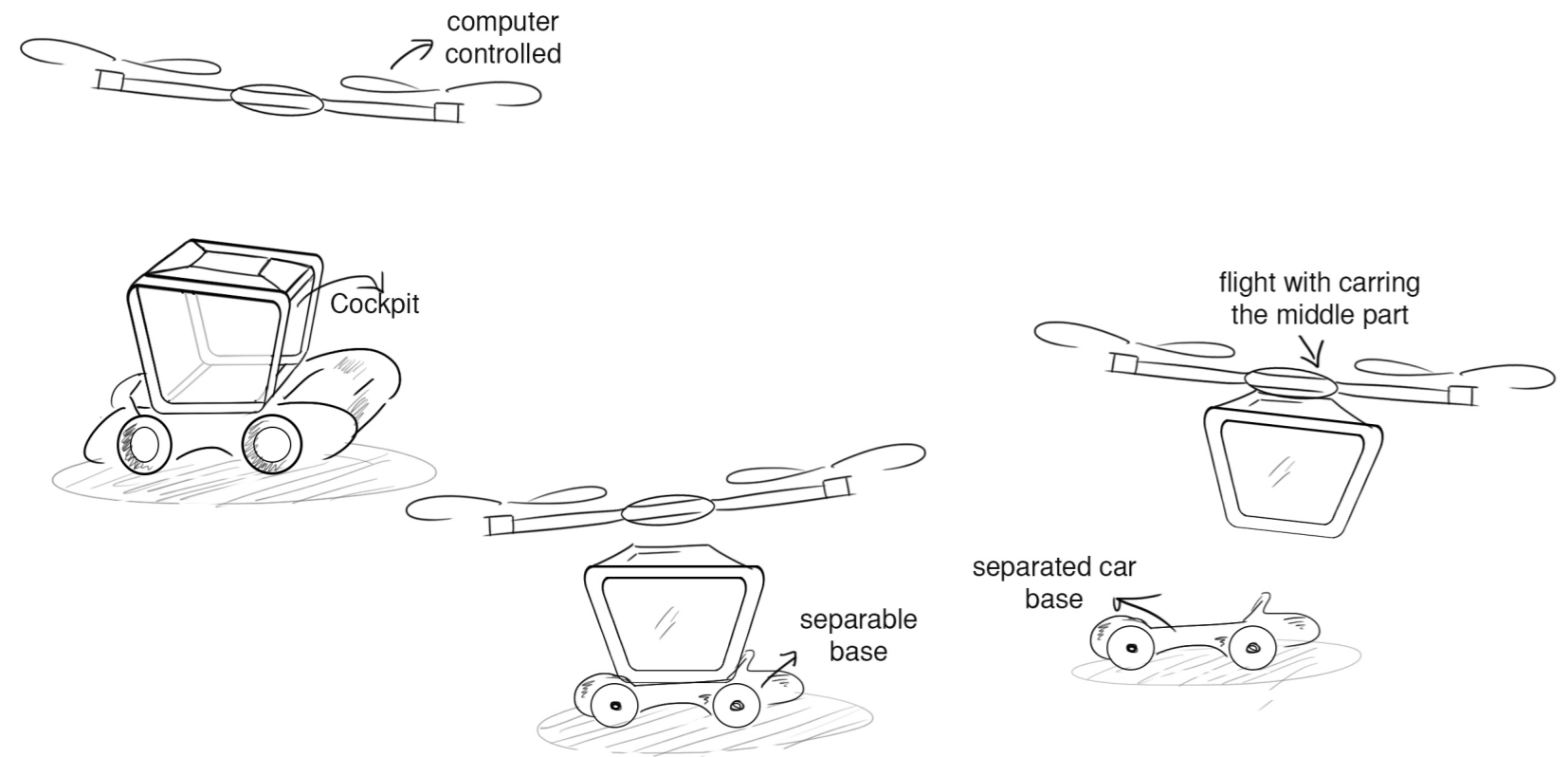

In this idea, the whole system is divided into three parts. The top part is only having the propeller system. The middle system has the main fuselage. The lower portion is having the landing gears. The three systems are detachable and changeable. The idea is to have a system where the propellers can be programmed to pick up a cockpit and detach it from the chassis and drop at a station on other chassis.

Image 23: Ideas 5

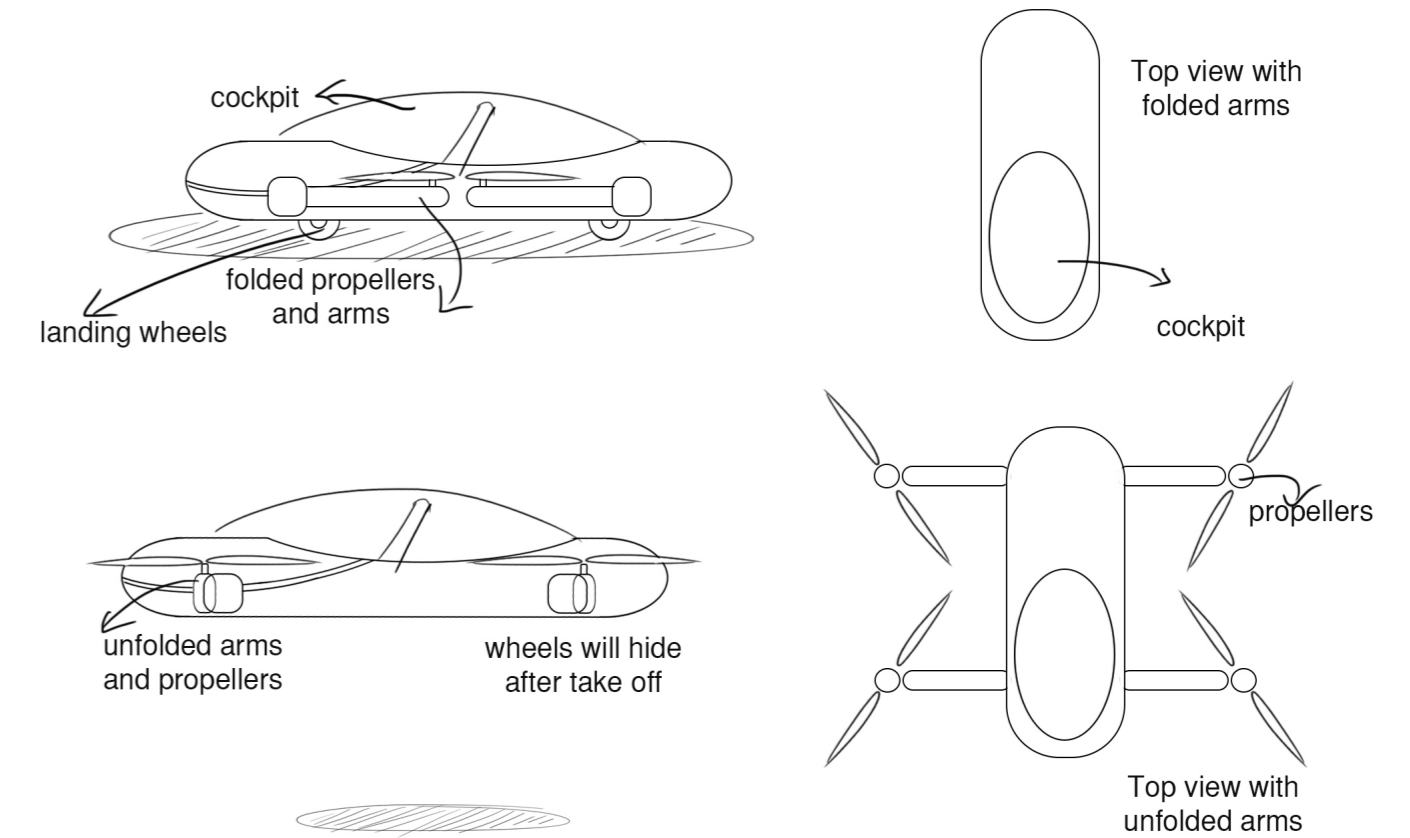

This idea is straight derived from a folding armed pocket drone. While the body is fixed, only the rotor arms are foldable. This is to design a space saving system. The landing gears are also attached to the base of the vehicle. None of the part is detachable.

Image 24: Ideas 6

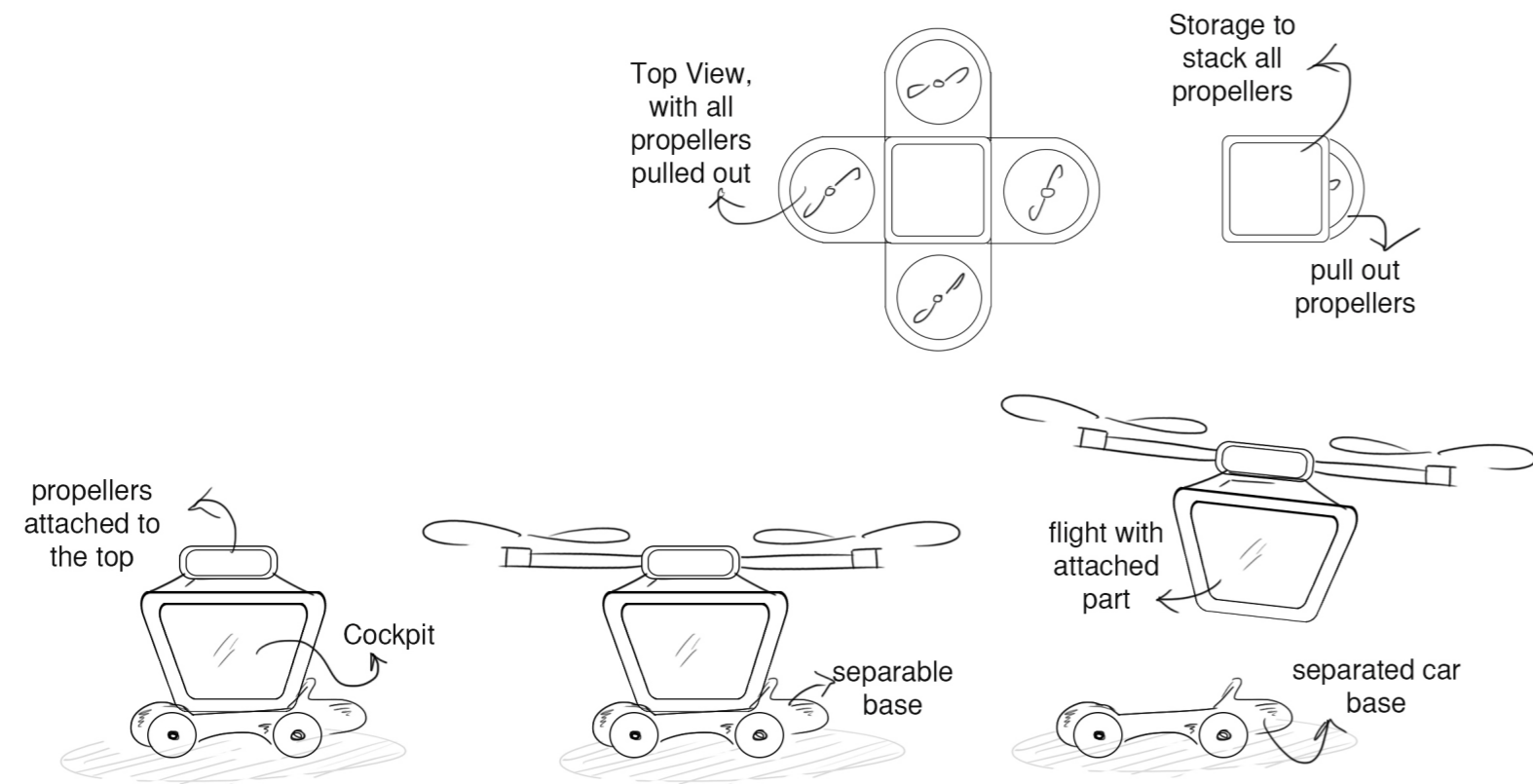

This idea is derived from the idea number 5. Here the system is designed more space saving than the previous one and the top part i.e the rotor section is not detachable, but stays with the middle unit. The propellers are designed in such a way that the four of them can easily slide inside a center container. This saves space while parking the vehicle.

Image 25: Ideas 7

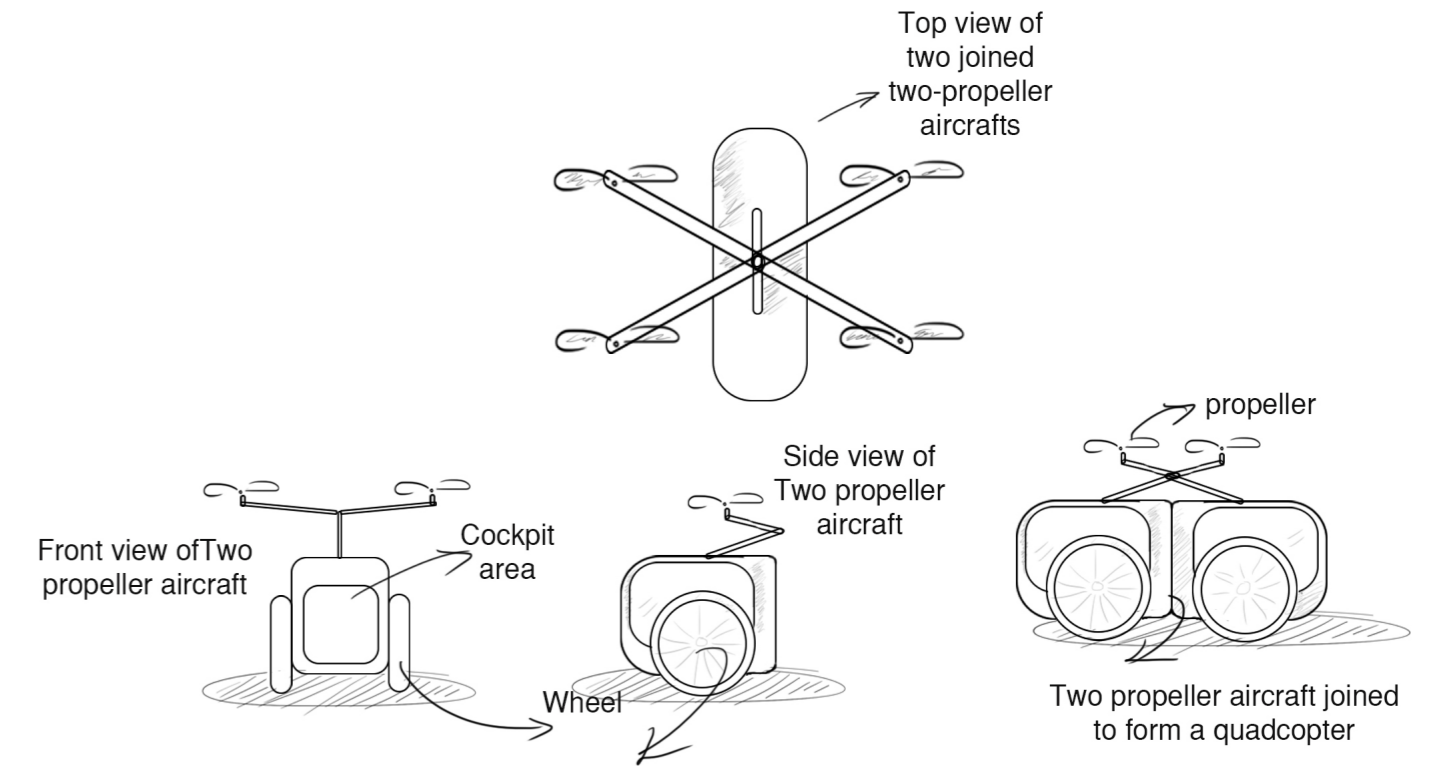

This idea is unique than all the other ones. This system was to have a single unit with rotors rather than four and a main body. The system is designed in such a way that two similar aircrafts can combine together end to end and form a quadcopter system then the entire unit can act as one single unit. There can be range of forms and sizes of the single system and are designed in such a way that they are compatible with each other and provide more and variant options for the usability and functionality.

Image 26: Ideas 8

07

Paper Models

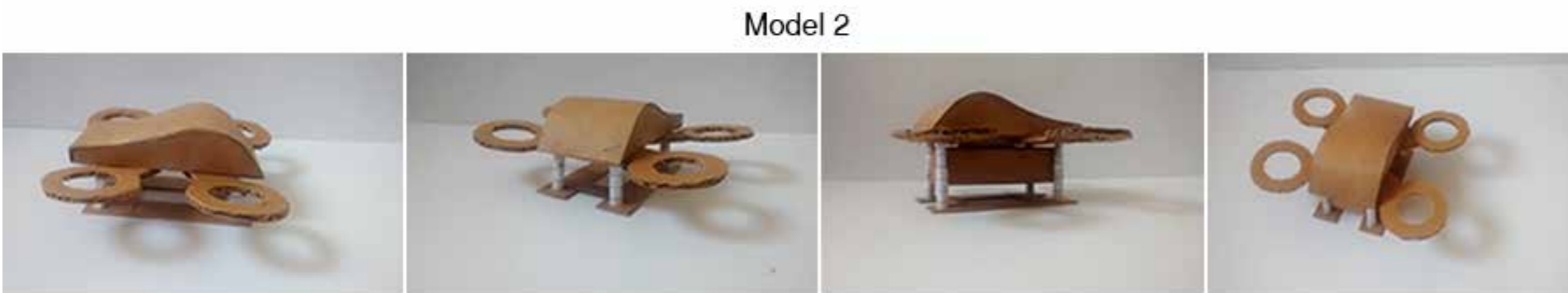
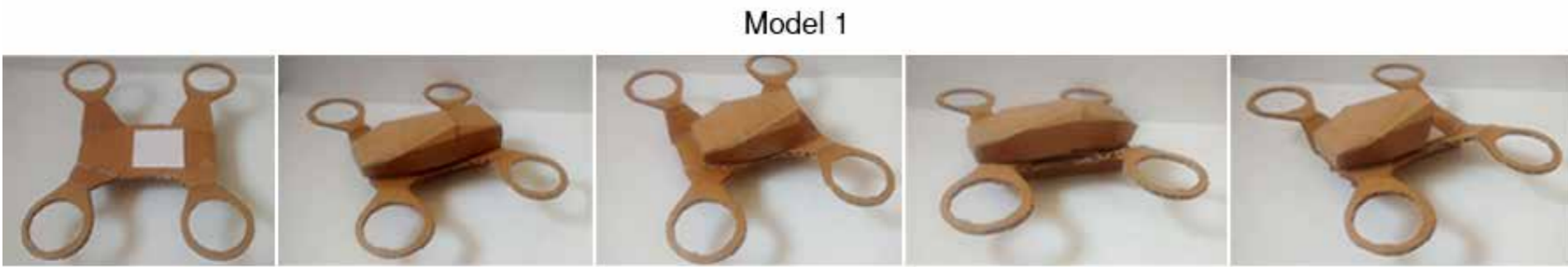

Image 27 : Models for refined ideas

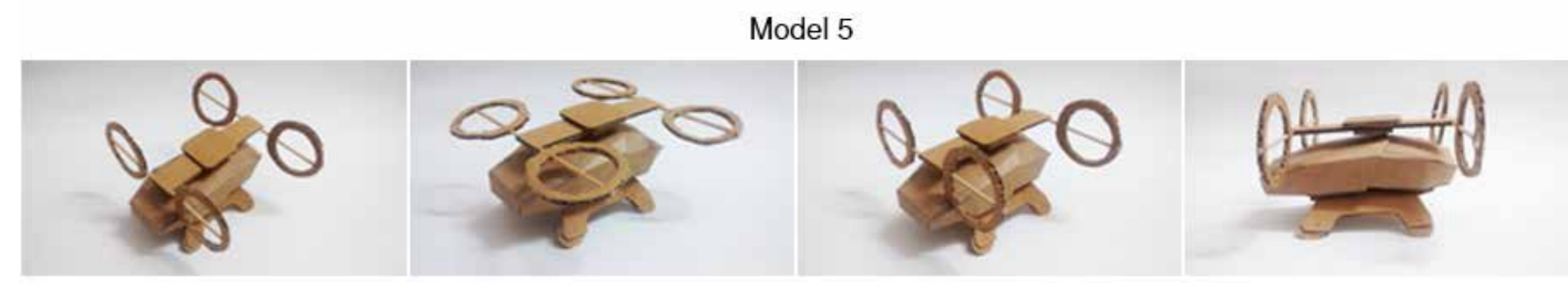

Image 28: Models for refined ideas

08

Sketches

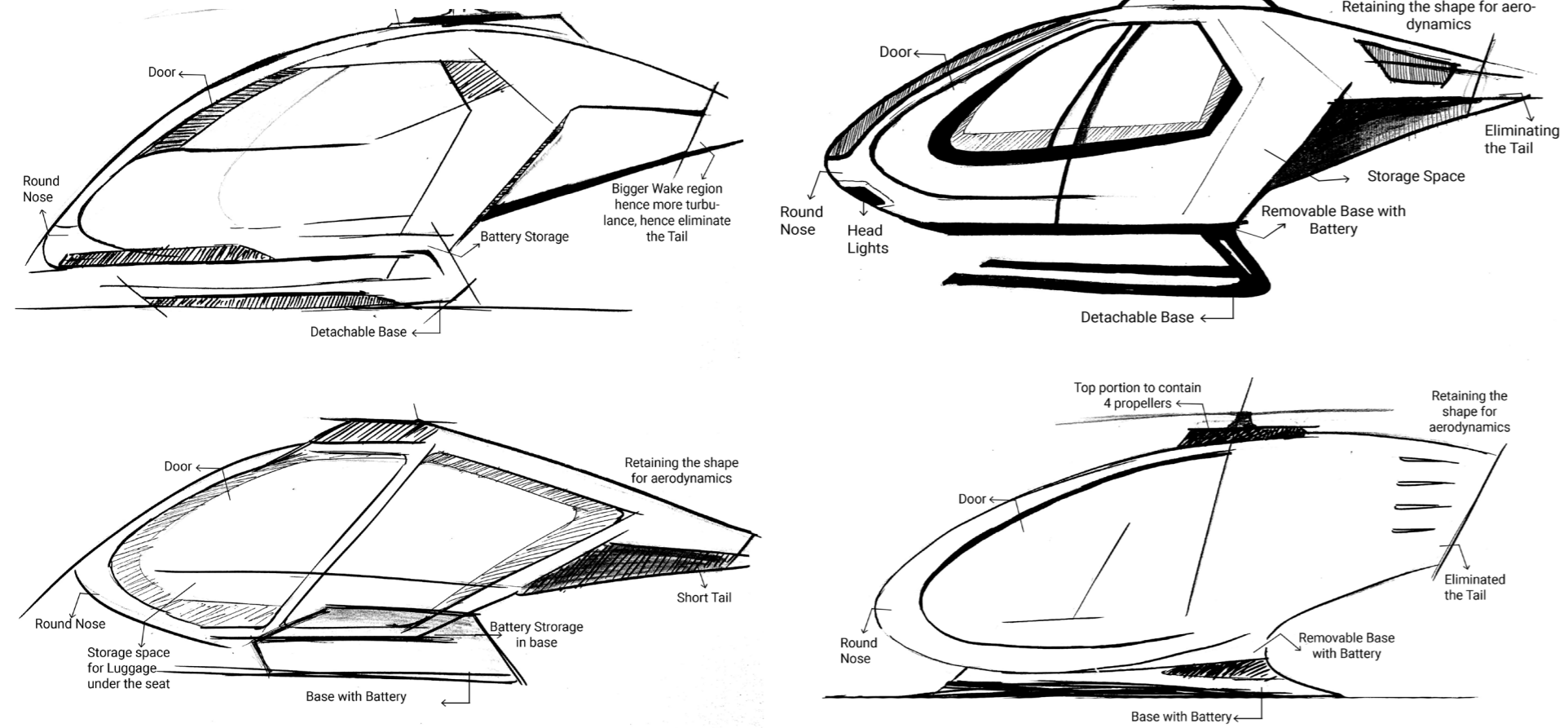

Image 29: Initial Ideations

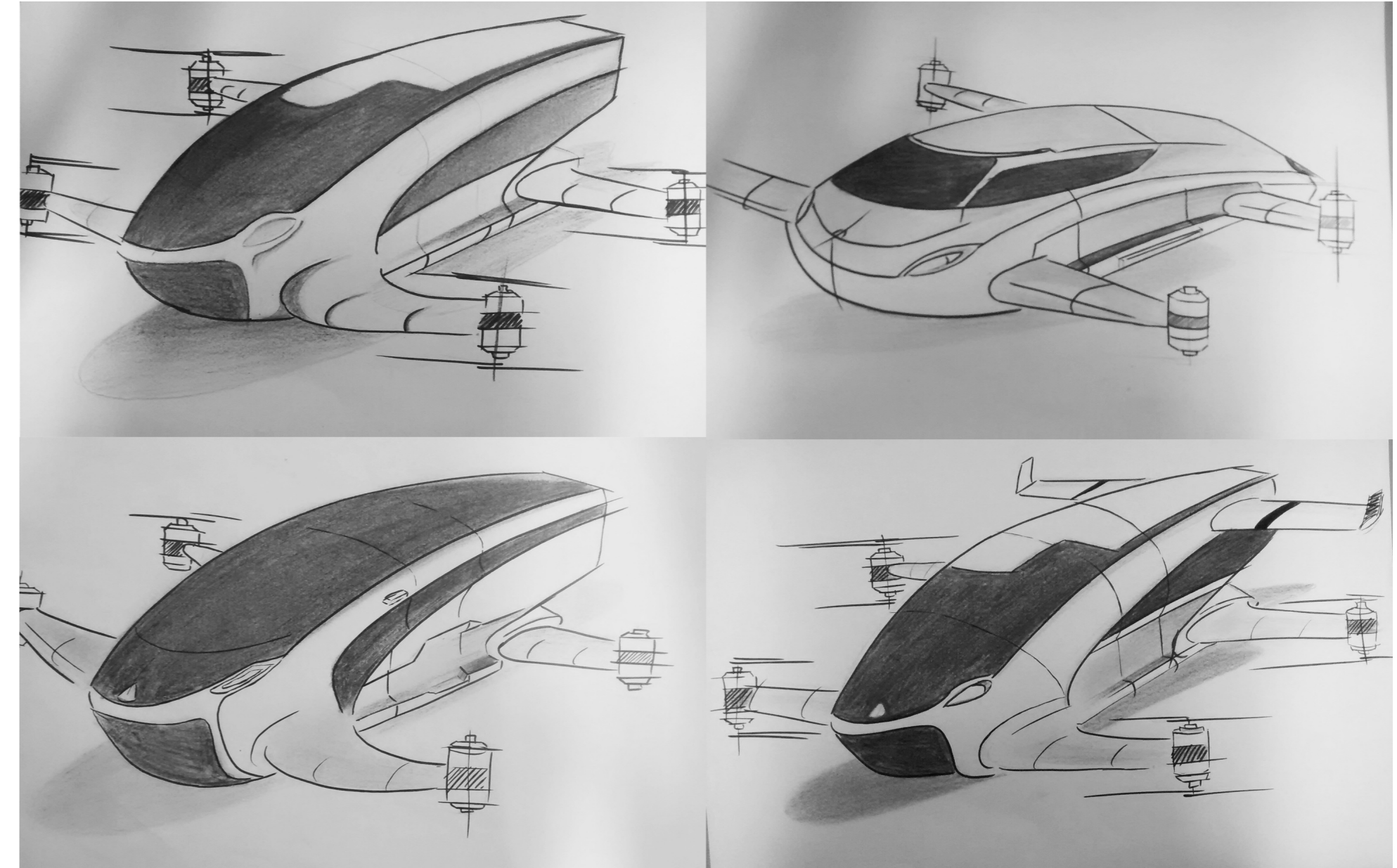

Image 30: Form Sketches

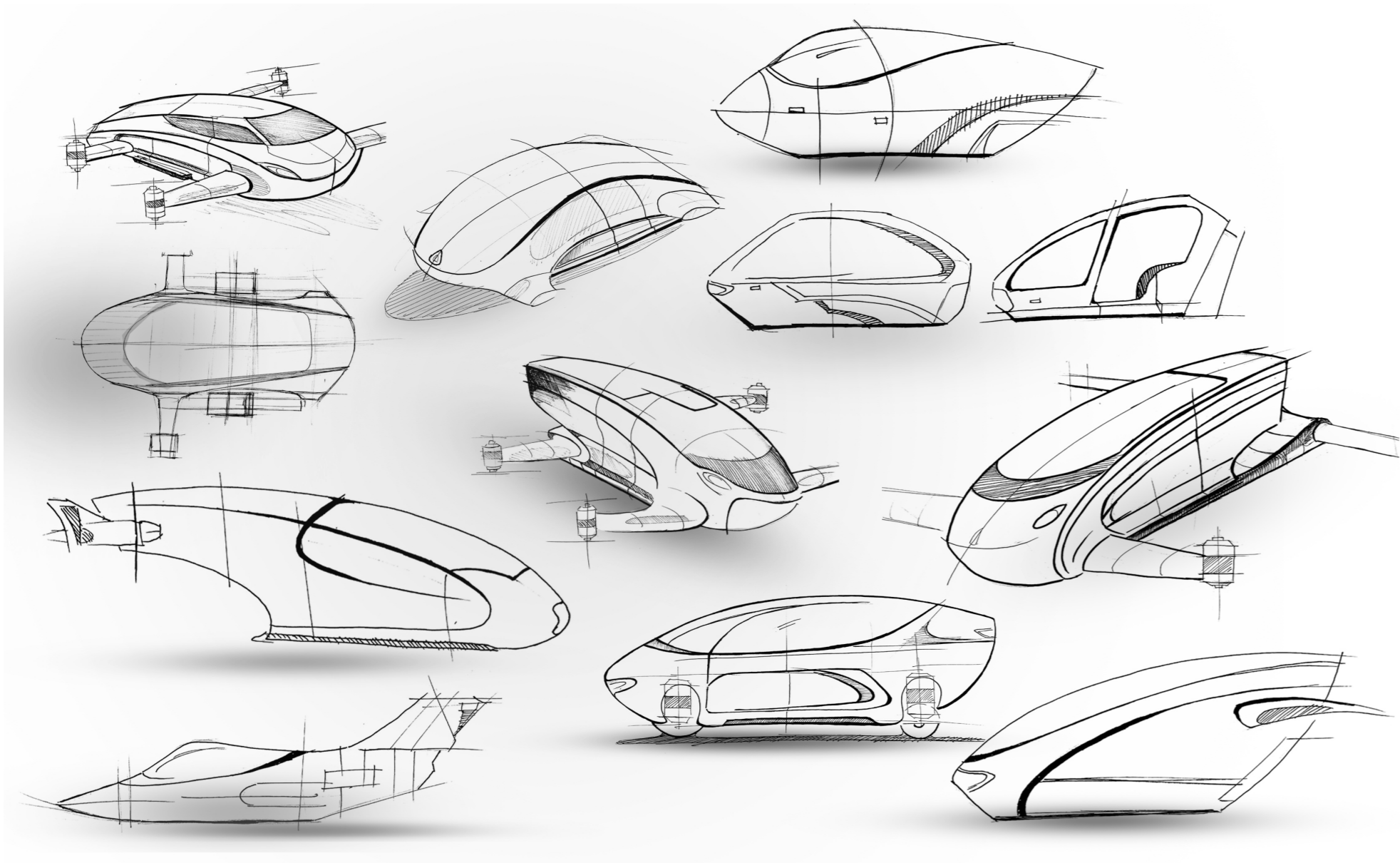
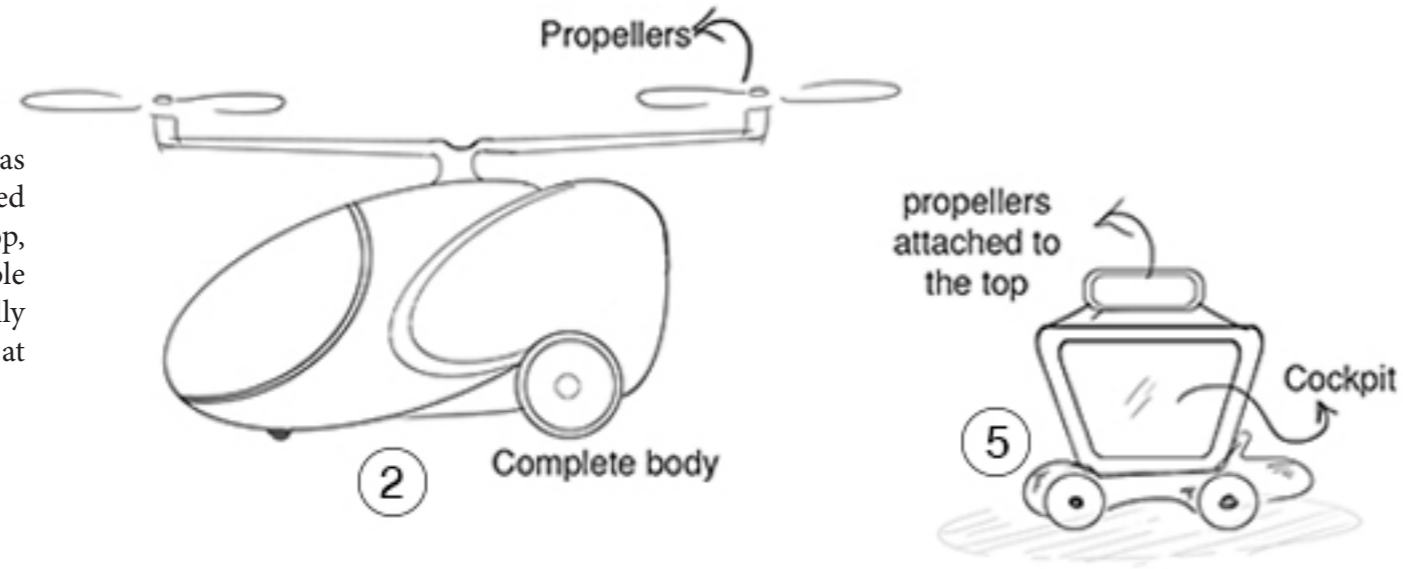

Image 31: *Fuselage Sketches variants*

09 Concepts

CONCEPT 1

Taking some elements of ideas 2 and 5, a concept is developed where the rotors are at the top, the whole fuselage is replaceable and capable of moving vertically in order to create storage space at the bottom.



- Detachable cabin
- Higher propeller

Added Features:

- Lift up/down



CONCEPT 2

Taking some elements of ideas 7, 8, 6 and 3 another concept is developed where the base is attached to the rotor system, there by creating one division of base and another system of fuselage. the Fuselage is replaceable.

The base is a universal design which could be used for multiple purposes.

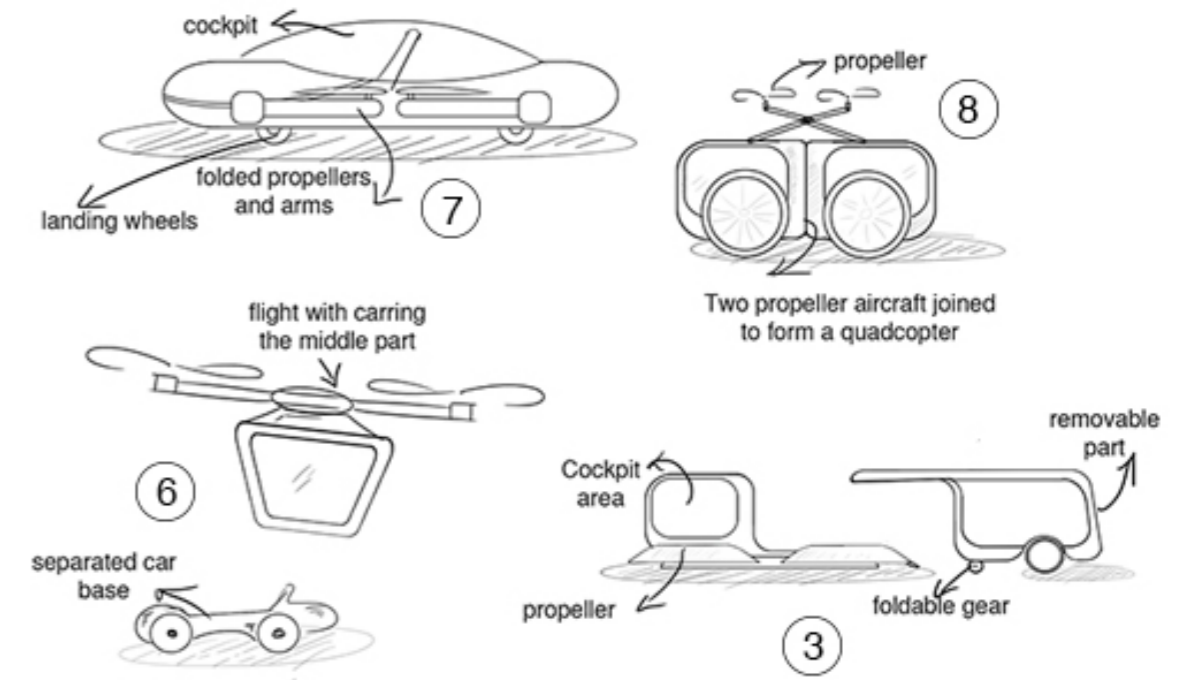

- Foldable arms
- Join 2 or more aircraft
- Removable cockpit
- Detachable front/rear cabin
- Lower propeller



Concept Evaluation

Categories	Concept 1	Concept 2
Stability	0	1
CG position	0	1
Modularity (removable parts)	1	2
Ease of assembly	1	1
Foldability	0	1
Safety	1	1
Extendable	0	1

Concept Evaluation Result

The two concepts were evaluated on the basis of 7 important points. The concept 1 seemed to be highly unstable as it has the propeller system at the top and the middle part of the fuselage is capable of moving vertically in-order to make storage space. All this combination will require large amount of power and mechanism which will add weight to the system. In a flying object the weight plays a vital role, thus we can try to eliminate unwanted weight by simplifying the mechanisms and design. Though in an aircraft structure the the propellers at the middle part of on top provides more lift to the entire system, the mechanism for folding arms, creating a common chassis and attaining stability at ground level would have been very difficult. At first look, the concept 2 proves that the majority of weight is at lower portion thus the CG(center of gravity) stays close to the ground there by providing stability.

The concept 1 has too many separated parts and is highly modular in mature. It has separated propellers, middle portion and the base unit. While the concept 2 has two major parts, the top portion and the base unit containing the propellers and landing gears. Thus it seems to have a modularity level slightly lower than the first concept. Since the 2nd concept has only two parts. Further adding modules to each part is easier and more significant. Here the lower part, chassis is easy to divide into modules of propellers, rotors, separable arms, removable battery, detachable fuselage, removable landing gears. All these smaller modules rate the concept to be more modular. The smaller module makes a system easier to assemble, simplifies manufacturability, and provides faster and easier repairing, replacing and availability of parts.

Since the chassis has the rotor system as well as the landing gears it will be easier to design a common or more universal chassis base model that can support more than one kind of a fuselage design. This increases the flexibility and utility of the entire system, not only in manufacturing line but also in production line. The second concept is more extendable than the first concept.

Safety plays a significant role in aircraft design.. Whether a system has the propellers at top of at the base they are equally unsafe and safe. The best way to provide safety is to provide propeller guards. The importance of having the propellers at the base is that, the air pushed will be downwards towards the ground like in any helicopter or aircrafts having them on top, but it will not bounce air columns directing on a person unlike helicopters.

10
Final Concept

Final Concept

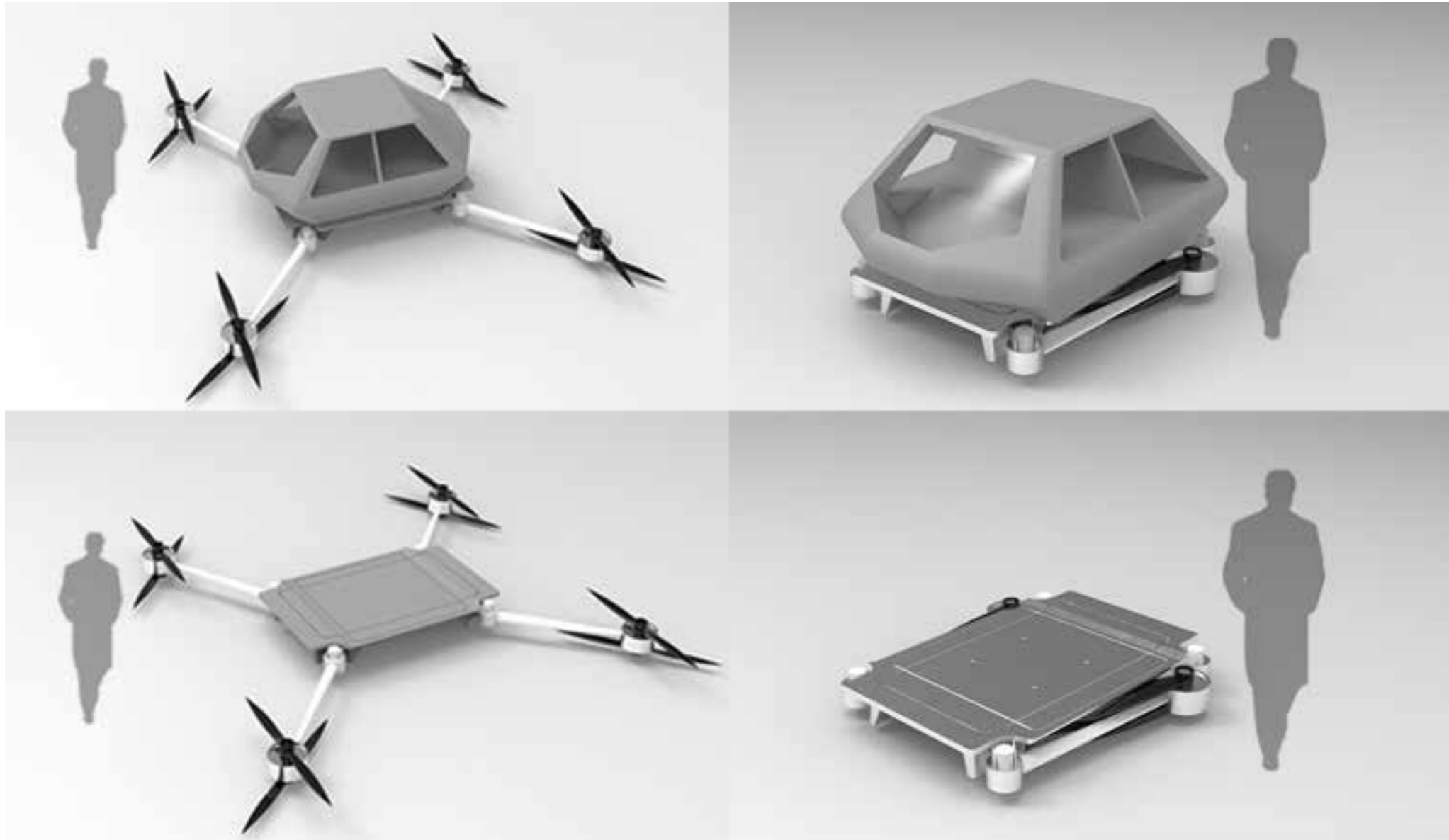

37

Image 34 : The base chassis has foldable arms containing the propellers.

Final Concept

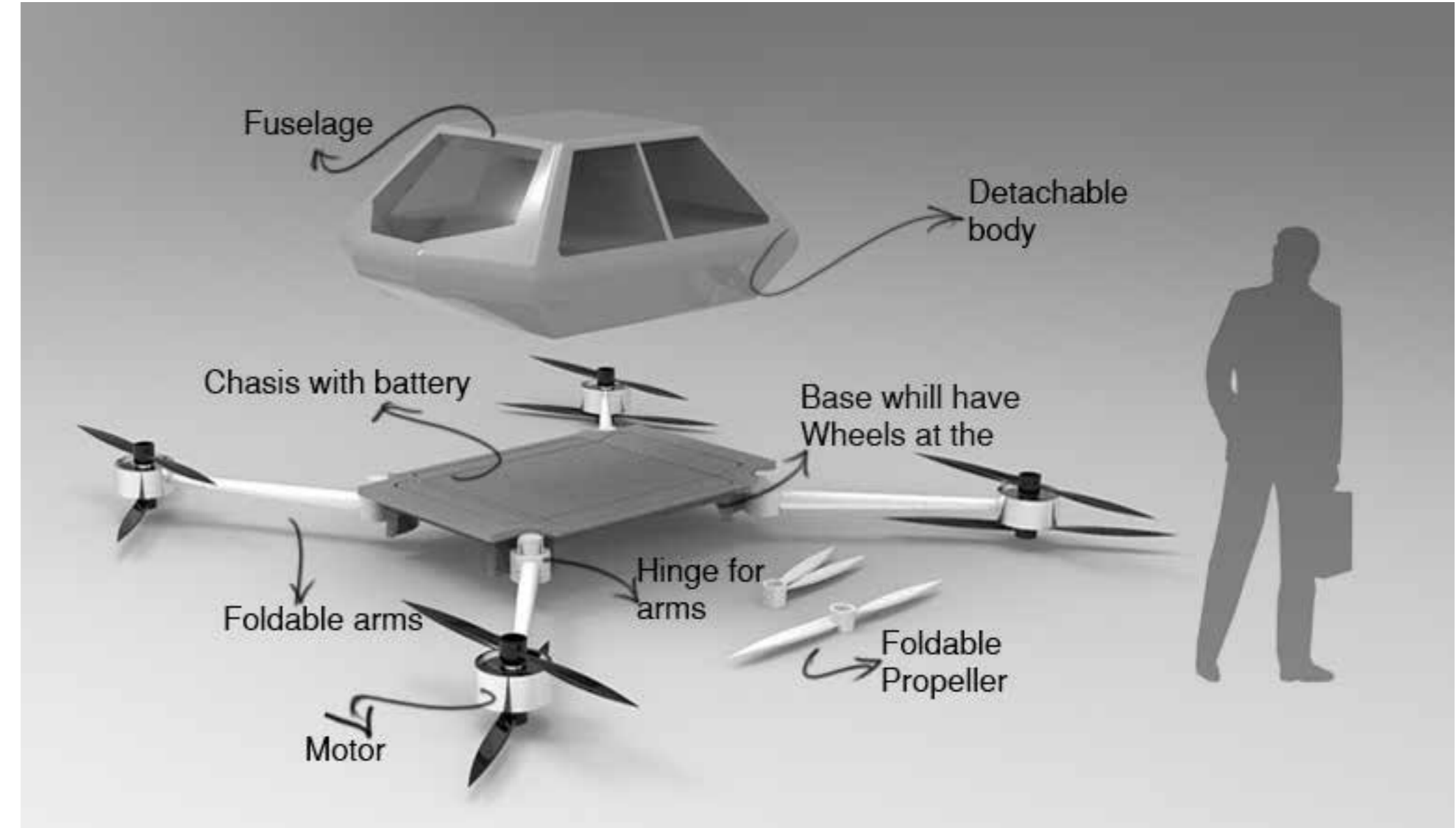

Image 35 : The main components of the design

38



Image 36 : A single chassis can be used for various different form of the fuselage as per the requirement

This separation allows for a unique system of differentiated vehicle, allowing selection of different frame sizes, extended cockpits, and several chests and containers of varying sizes.

Components for modular vehicles can be selected based on need, i.e. shared taxi services, private taxi, executive, luxury aircraft, private planes, cargo aircraft.

11

3D Modelling

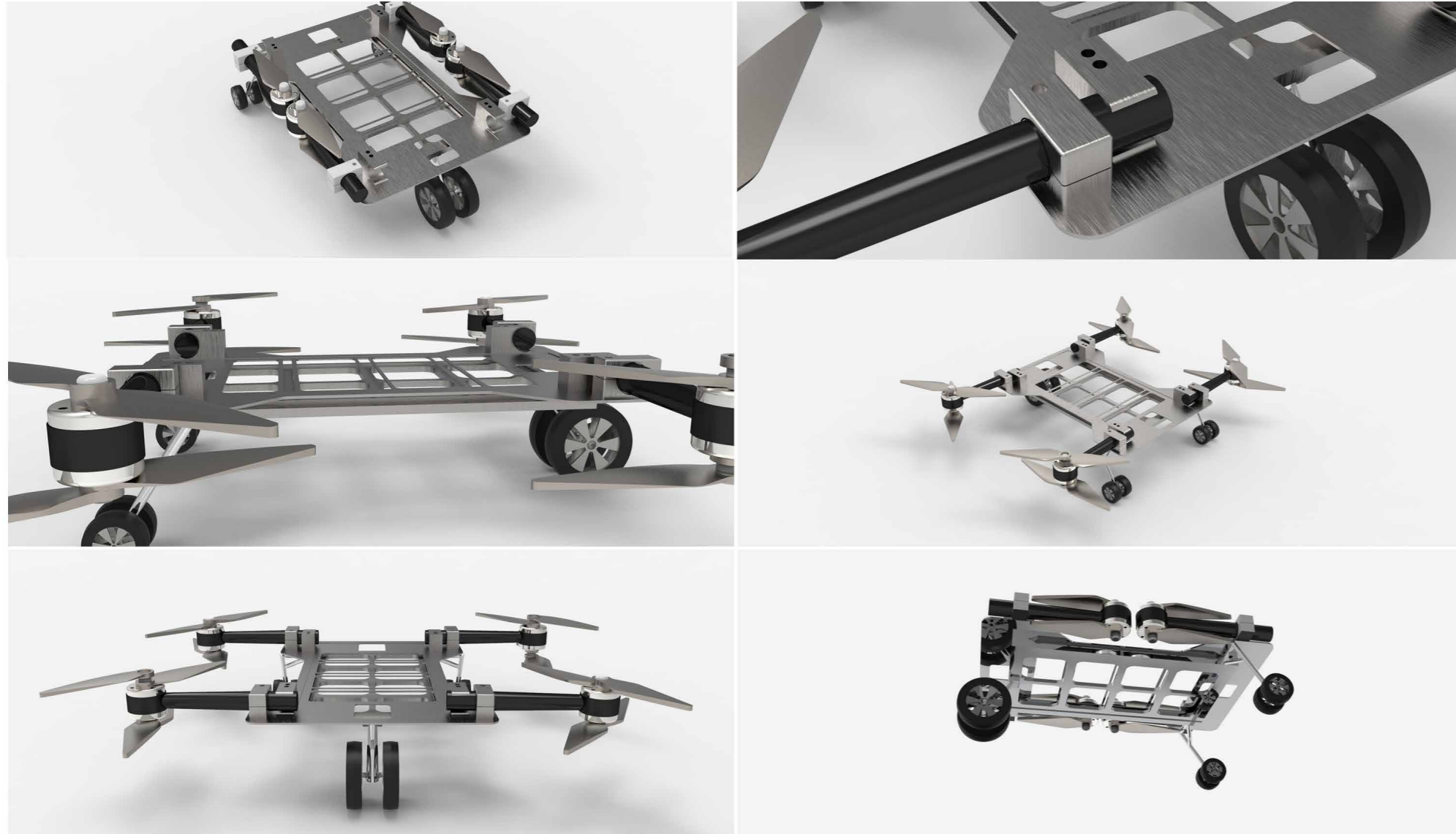

Image 37 : Main chassis design. It has the landing gears and rotors along with propellers in one single unit

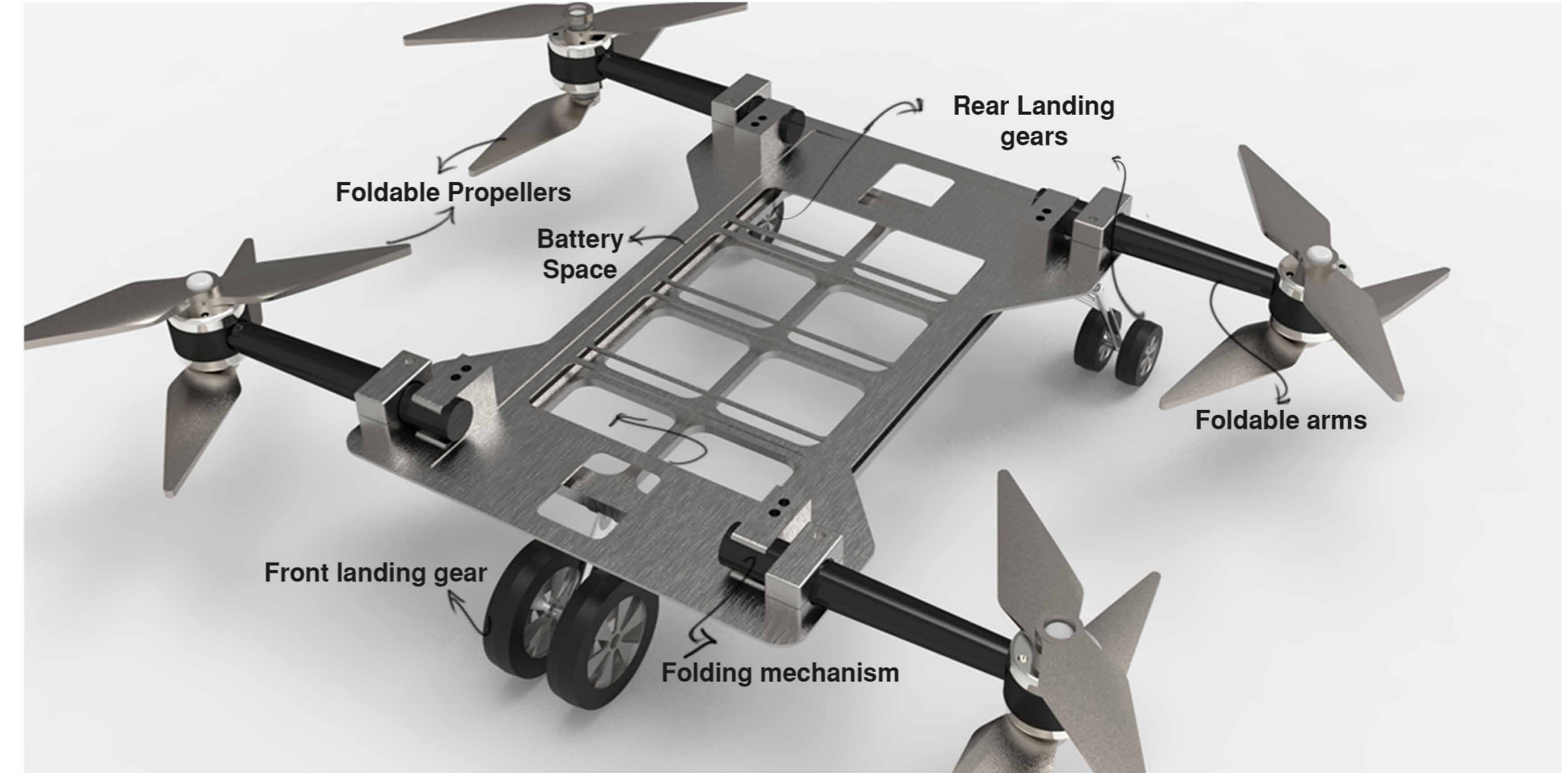

Image 38 : Main chassis design - main parts

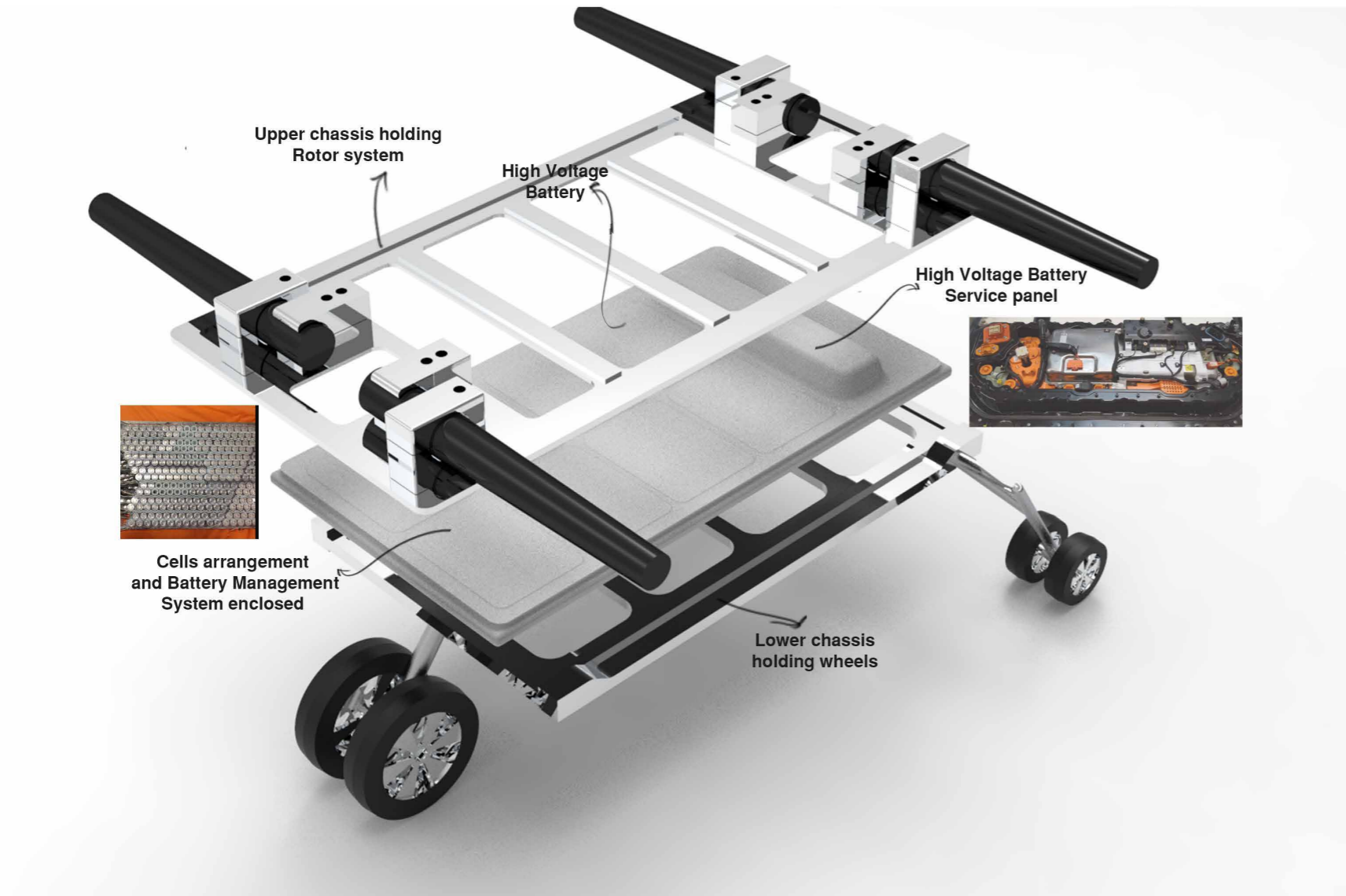

Image 39 : Main chassis design - Expanded view

Battery Pack

1 panasonic (18650 type) lithium ion cells (54 grams single unit)
 18mm(dia), 65 mm (height), 4Ah capacity, 3.6 volts
 1 Brick= 60 cells (parallel)
 1 module= 10 bricks (series)
 10 modules (series)

6000 Cells
 Power: 86.4 kWh
 Battery Voltage: 360 V
 Battery Weight: 380 kgs
 Battery size(with 6000 cells):
 2000 mm(L) x 1200 mm(B) x 100mm(H)
 Endurance: 15 minutes

Motors Specifications (per motor)

Shaft Diameter:20mm
 Motor Dimensions(Dia.*Len):= 150 x 300 mm
 Weight (Kg): 25 Kg
 Number of motors: 8
 Power: 20 hp

Propellers

Number of propellers: 8
 Propeller : 30 inch
 Maximum Thrust - 200Kg at 4500 RPM per motor

Weight

Passenger: 400 kg
 Battery :300 kg
 Body: 500 kg

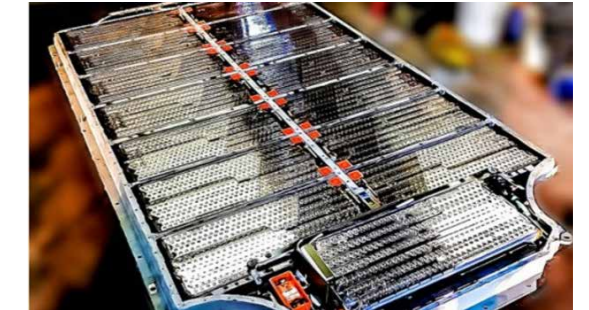

Image 40 : Battery Pack
(reference image)



Image 41: U15-KV100 Motor
(reference image)



The interior has been kept simple and easy and very similar to the automobiles like car, this gives the user a look and feel experience and easier to connect with the interface.

Image 42: Interior of the Helicopter

12 Model Making

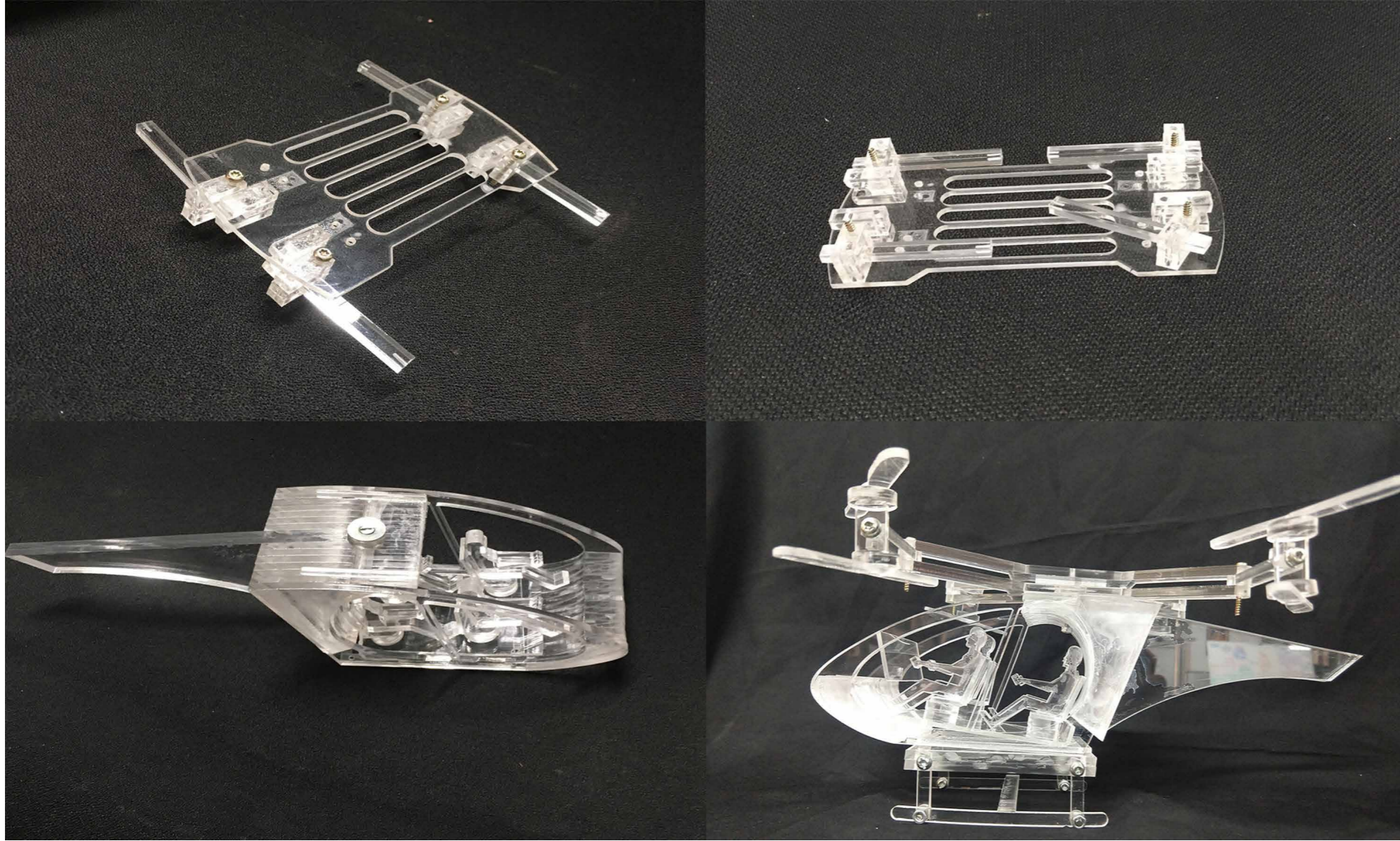

Image 43 : Model - fuselage and Chassis. The simple mechanism of the foldable arms is shown in the base chassis. The folding mechanism in the arms and rotating rotors is also prototyped.



Image 44 : Model - fuselage and Chassis, using mdf to create the basic form of the fuselage

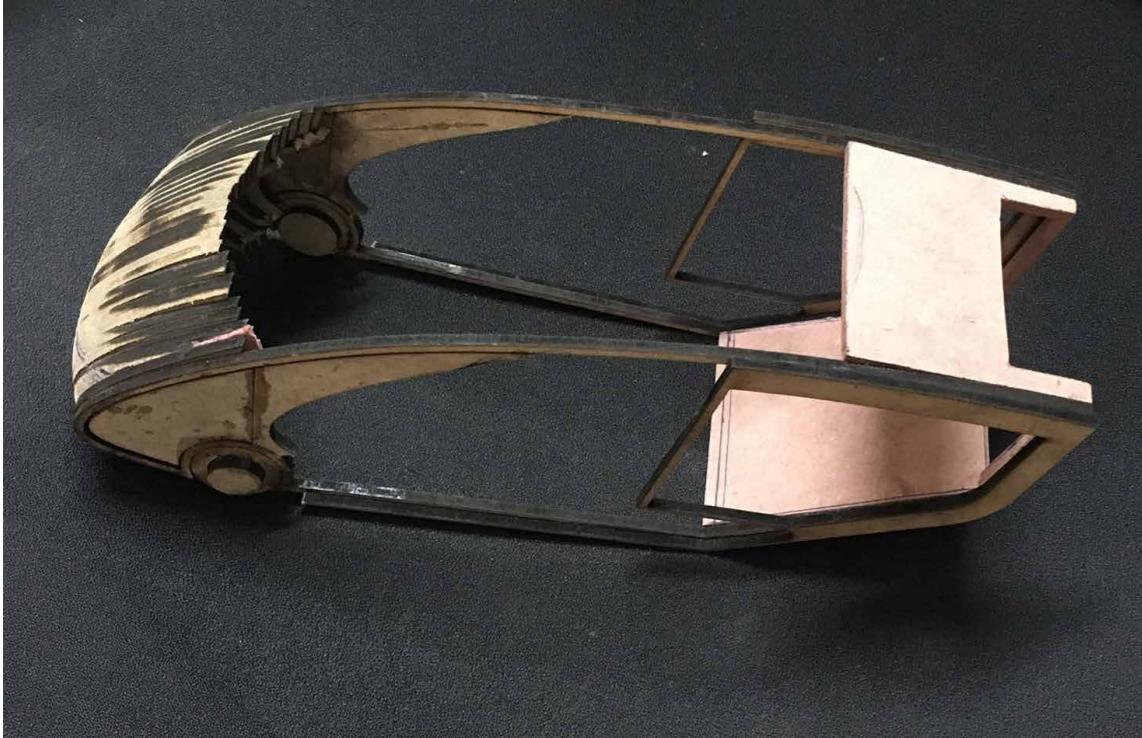

Image 45: Main body of the final Prototype In progress



13 Mechanism

Doors

The final design will be having two doors only rather than four doors. It will have Scissor door open.

Benefits of having 2 doors over 4 doors:

- A vehicle with two doors in comparison to four, is more aerodynamic due to its lack of additional weight.
- The styling of a 2-door is almost always cleaner, more attractive and more stylish than a 4-door.
- Two doors makes for a more rigid and lighter structure, which improves the vehicle's handling and performance.
- Two-door cars have a tendency to be compact, which makes them easier to park.
- It Requires Less Repairs and Maintenance.
- They are slightly cheaper than 4 doored.

Scissors door designs: rotate vertically at a fixed hinge at the front of the door, and open by rotating on a horizontal axis, perpendicular to the vehicle's length.



Image 46: Door opening mechanism in Toyota Yui

<https://www.theverge.com/2017/1/4/14169960/toyota-concept-i-artificial-intelligence-yui>

Front Easy Entry Seats:

Since there are only two doors, hence the back seaters will use the front doors only for entry. The rear seat passengers easy entry and exit, just push the lever on the back towards the rear of the vehicle to tilt the seat forward to return the seat to a sitting position push the seat toward the rear of the vehicle until the track locks the rotate the seat back upright until it locks.



Image 47: easy access to rear seat on Jeep Wrangler

<https://www.youtube.com/watch?v=PwBulTizsmA>

Folding Propellers and Arms:

The arms holding the motors will be foldable in order to save space while parking or not in flight mode. The propellers will also be foldable in order to accommodate them under the when arms are folded.



Image 48: Folding arm mechanism

<https://www.amazon.com/ZEROTECH-Definition-Version-Official-Warranty/dp/B01M1E1CRE>



Image 49: Folding propellers mechanism

<http://www.helipal.com/djim6-58-2195-foldable-propeller-cw-ccw.html>

14
Dimensions

Fuselage
Height: 1626 mm
Width: 1912mm
Length: 4780mm

Horizontal Shaft distance: 6118mm

Vertical Shaft distance: 4221mm

Ground Clearance: 382mm

Lights
Head light and Tail lights
Arm Light: 4pcs (2 red-port, 2 green-Starboard)

Charging Port: 1

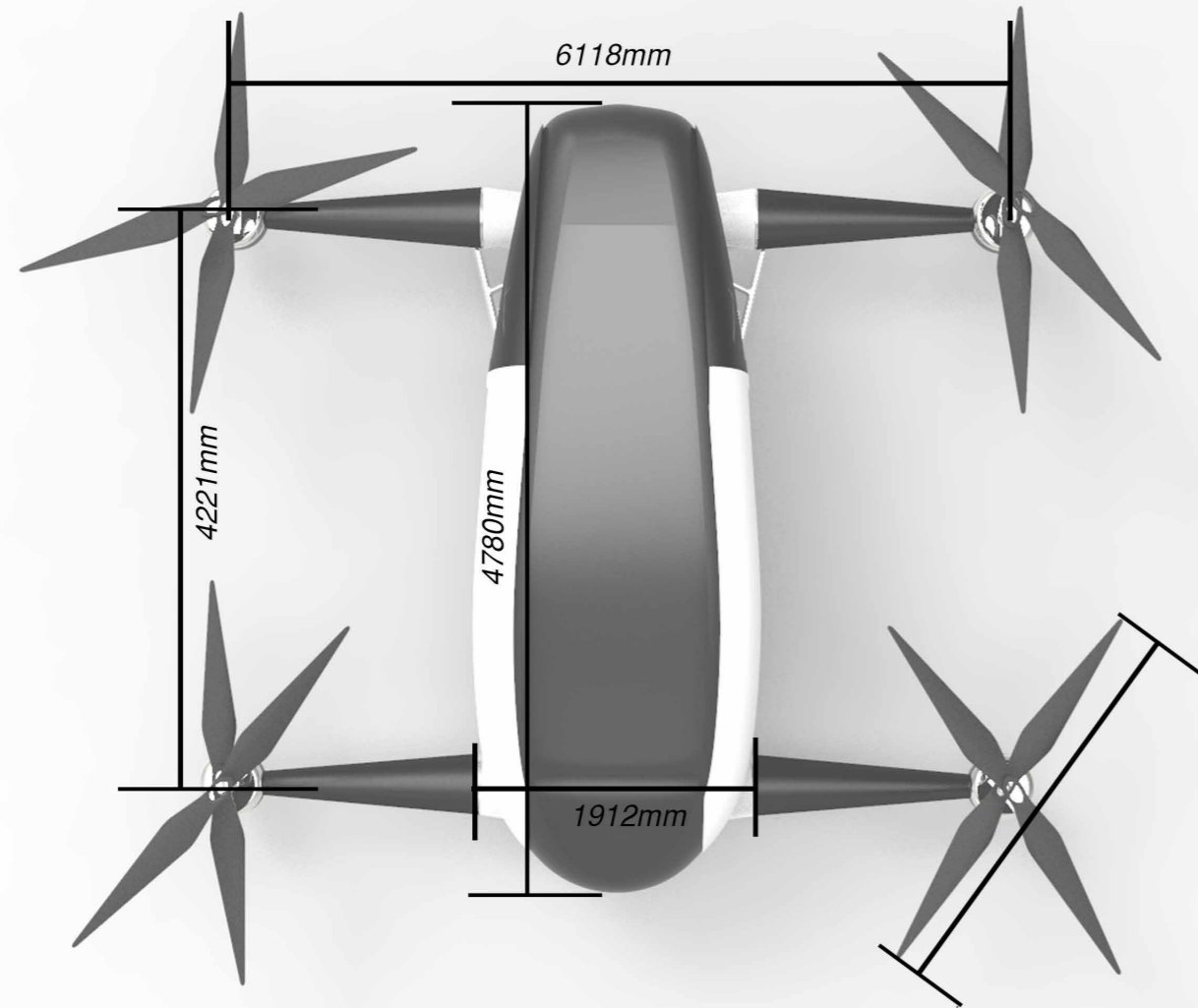

Image 50: Dimensions

15 Modular Vehicle Platforms

Modular Design Benefits

- Modular vehicles make it possible to use different types of bodies on one standardized chassis.
- Modular chassis, with its batteries and motor, are relatively easy to work on, since there is no vehicle body to impede access
- With a common architecture for multiple models and variants, the enormous cost of vehicle development can be spread over a wider range of aircraft.
- Savings are also possible in manufacturing where the single platform occupies just one production line, and the processes that define and differentiate each model happen later.
- Modular products enable faster, easier and more efficient customisation of standard products to unique user needs.
- Modules can be modified or replaced without changing anything else on the product.
- Modular design simplifies the information processing in a design project.
- Modular design enables quick and easy upgrades (driven by either technology or user improvement), thus enabling products to evolve.
- During design, different modules can be developed by separate groups of engineers at the same time. Designing modules/assemblies simultaneously like this (often referred to as concurrent engineering), reduces overall time-to-market for a product, therefore maximising total sales and revenue.
- If any future problems arise with the design of a product or a periodic redesign exercise takes place, modules can be separately improved (such as for localised problems), before being reintroduced into the whole product. They do not have an impact on other assemblies, as would be the case with integral design.

[Ref 14]

16
Branding

Name: Vehicle is named as Dexter which means skillful

As the design is to accommodate multiple fuselage on a standardized chassis, the vehicle can serve as multipurpose and can perform multiple tasks based on the usability. Thus the name DEXTER means skillful.

Logo

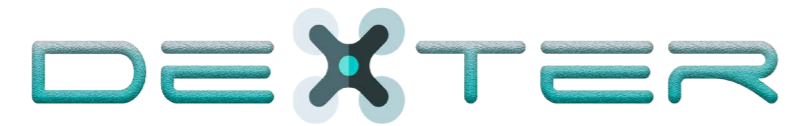
The logo for 'DEXTER' features the word in a stylized, teal-colored font. The letter 'X' is replaced by a black cross symbol with a small teal dot at its center. The letters 'D', 'E', 'T', 'E', and 'R' are outlined in teal and filled with a light grey gradient.

17
Final Product



Image 51: Rendered image of Completed model

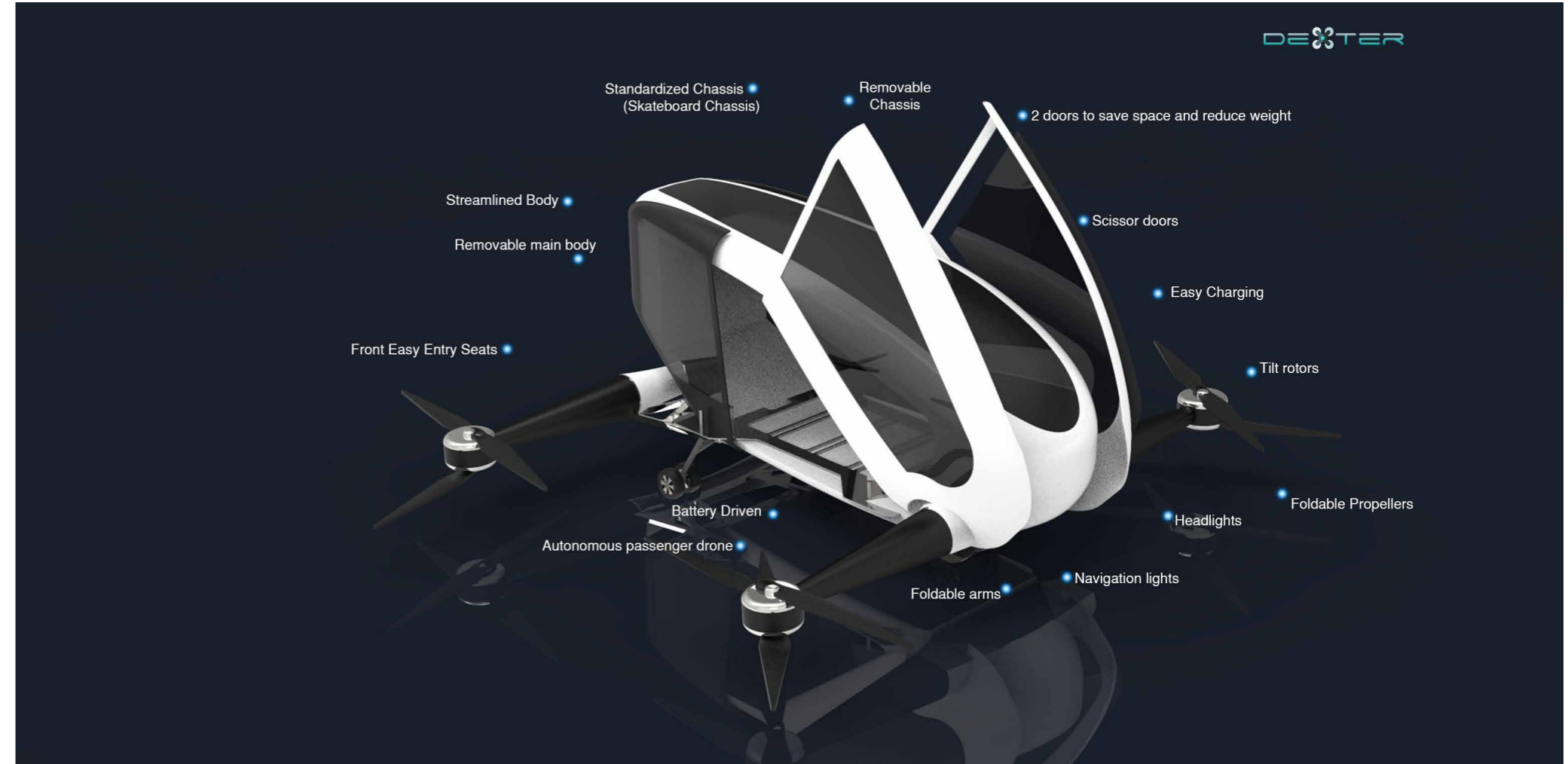

Image 52: Rendered image of Completed model



Image 53: Completed model using MDF

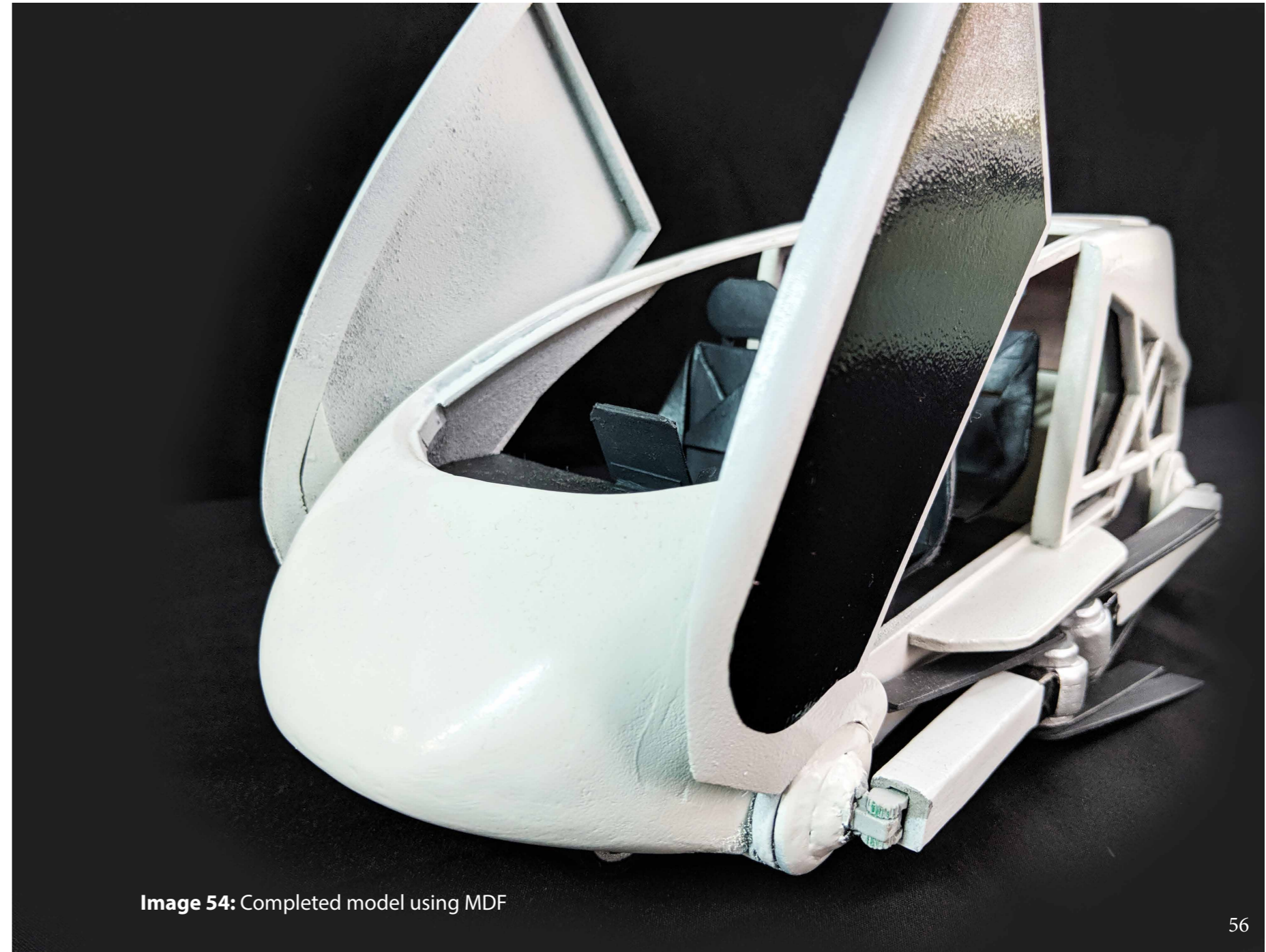
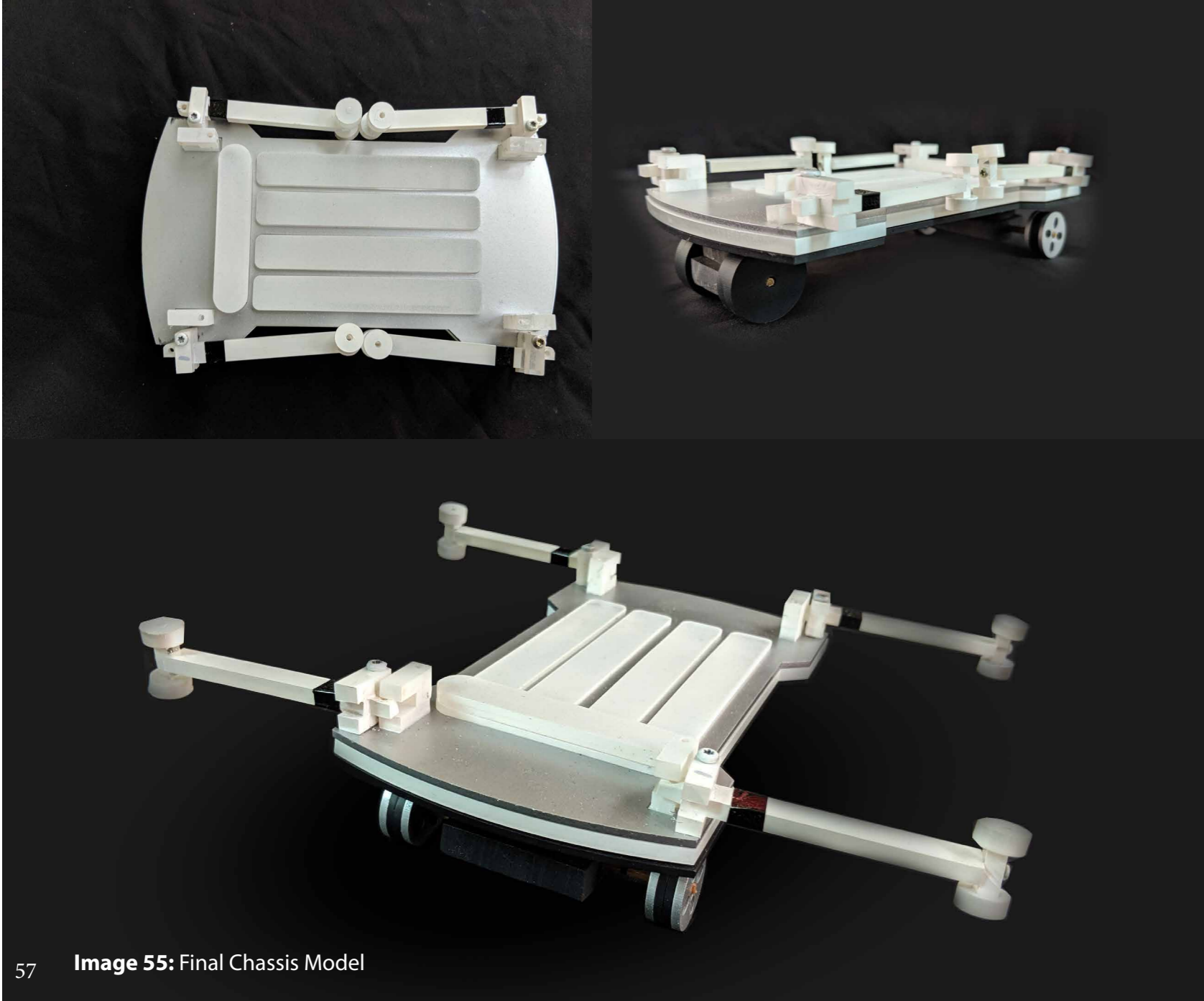

Image 54: Completed model using MDF



57 **Image 55:** Final Chassis Model

18

Significance of Color

WHITE

- Airlines often end up selling their aircraft to other carriers, they will find it harder to do so if the color scheme is anything but white.
- They reflect sunlight and minimises both the heating and any potential damage from solar radiation.
- It makes it easier for any cracks, dents, oil spills and other faults to be identified and repaired swiftly.
- A white plane is easier to spot during search and rescue process.

- 1 Addition of long-distance heart procurement promotes changes in heart transplant waiting list status
<https://www.ncbi.nlm.nih.gov/pmc/articles/PMC4412323/> (Nov 2018)
- 2 Ehang 184
<http://www.ehang.com/ehang184/> (Nov 2018)
- 3 How Drones Can Help Transport Human Organs
<http://www.wvxu.org/post/how-drones-can-help-transport-human-organs#stream/0> (December 2018)
- 4 8 Futuristic Car Features:
<https://techstory.in/8-futuristic-car-features/> (January 20, 2019)
- 5 What will cars really look like by 2050?
<https://blog.donedeal.ie/2016/07/will-cars-really-look-like-2050/> (January 12, 2019)
- 6 The History of Drones: a wonderful, fascinating story over 235+ years
<https://www.dronesbuy.net/history-of-drones/> (Feb 10, 2019)
- 7 There Should Be Modular Cars That Can Do Anything
<https://jalopnik.com/there-should-be-modular-cars-that-can-do-anything-1689917124> (March 02, 2019)
- 8 Flying car:
<https://www.designboom.com/tag/flying-car/> (Feb 2, 2019)
- 9 Passenger Drones:
https://en.wikipedia.org/wiki/Passenger_drone (Feb 02, 2019)
- 10 The Tesla Model 3 interior is unlike anything we have ever seen before
<https://www.businessinsider.in/The-Tesla-Model-3-interior-is-unlike-anything-we-have-ever-seen-before/articleshow/62951516.cms> (March 02, 2019)

- 11 How an electric car works
<https://www.youtube.com/watch?v=3SAxXUlr28> (Mar 02, 2019)
- 12 Modular vehicle
https://en.wikipedia.org/wiki/Modular_vehicle (Mar 09, 2019)
- 13 DIY cars - Soon Modular Vehicles
<https://eluxemagazine.com/homestech/eco-tech/soon-modular-vehicles/> (May 20, 2019)
- 14 Modular Design Benefits Including Modular Manufacturing
<http://www.advice-manufacturing.com/Modular-Design-Benefits.html> (May 20, 2019)
- 15 Benefits of Owning a Two-Door Car
<http://www.autosreign.com/two-door-car.html> (June 02, 2019)
- 16 This passenger-carrying drone just completed more than 1,000 test flights
<https://www.indiatoday.in/education-today/gk-current-affairs/story/ehang-184-the-people-moving-drone-completes-more-than-1-000-test-flights-1165671-2018-02-09> (June 20, 2019)
- 17 Workhorse Group Announces Intention to Spin Off SureFly Business
<https://www.globenewswire.com/news-release/2017/12/27/1274909/0/en/Workhorse-Group-Announces-Intention-to-Spin-Off-SureFly-Business.html> (June 20, 2019)
- 18 Airbus completes first test of its autonomous air taxi Vahana
<https://venturebeat.com/2018/02/02/airbus-completes-first-test-of-its-autonomous-air-taxi-vahana/> (June 20, 2019)
- 19 Airbus Modular Mobility System Pop.Up Brings Convergence To Cars & Aircraft
<https://cleantechnica.com/2019/04/18/airbus-modular-mobility-system-pop-up-brings-convergence-to-cars-aircraft/> (June 20, 2019)
- 20 Bell Reveals Its 5-Seat Nexus Air Taxi At CES Las Vegas
<https://cleantechnica.com/2019/01/16/bell-reveals-its-5-seat-nexus-air-taxi-at-ces-las-vegas/> (June 20, 2019)

- 21 The Four Forces of Flight
https://www.nasa.gov/audience/foreducators/k-4/features/F_Four_Forces_of_Flight.html (June 20, 2019)
- 22 How does a streamlined body reduce drag?
<https://www.quora.com/How-does-a-streamlined-body-reduce-drag> (June 20, 2019)
- 23 Quadcopter
<https://en.wikipedia.org/wiki/Quadcopter> (June 20, 2019)
- 24 How do drones fly? Physics, Of Course!
<https://techstory.in/8-futuristic-car-features/> (January 20, 2019)
- 25 How A Quadcopter Works With Propellers And Motors Explained
<https://www.dronezon.com/learn-about-drones-quadcopters/how-a-quadcopter-works-with-propellers-and-motors-direction-design-explained/> (January 12, 2019)
- 26 The History of Drones: a wonderful, fascinating story over 235+ years
<https://www.dronesbuy.net/history-of-drones/> (Feb 10, 2019)
- 27 Tiltrotor
<https://en.wikipedia.org/wiki/Tiltrotor> (March 02, 2019)

List of Figures

Image 1 : Modular Vehicle with two main modules (chassis and main body).....	1
Image 2 : A brief history of drones	2
Image 3 : A brief summary of the history of drones – Timeline Infographic.....	3
Image 4 : Breguet-Richet Gyroplane No.1.....	4
Image 5(a) : Oemichen No.1	5
Image 5(b) : Oemichen No.2	5
Image 6 : De Bothezat Helicopter	6
Image 7(a) : Convertawings with crew	7
Image 7(b) : Convertawings Model A	7
Image 8(a) and 8(b) : Two prototypes of Curtiss Wright VZ-7. 1958	8
Image 9 : Ehang 184	9
Image 10 : Surefly	9
Image 11 : Airbus CityAirbus	9
Image 12 : Vahana	10
Image 13 : Pop.Up.....	10
Image 14 : Nexus eVTOL	10
Image 15 : Forces acting on an aircraft in air	11
Image 16 : Streamlined body and drag resistance	12
Image 17 : Rotational directions on quadcopters	14
Image 18(a) Flight dynamics of Quadcopter	15
Image 18(a) Flight dynamics of Quadcopter	16
Image 19 : Idea 1	20
Image 20 : Ideas 2	21
Image 21 : Ideas 3	22
Image 22 : Ideas 4	23
Image 23 : Ideas 5	24
Image 24 : Ideas 6	25
Image 25 : Ideas 7	26
Image 26 : Ideas 8	27

Image 27 : Models for refined ideas	28
Image 28 : Models for refined ideas	29
Image 29 : Initial Ideations	30
Image 30 : Form Sketches	31
Image 31 : Fuselage Sketches variants	32
Image 32 : Developing Concept 1	33
Image 33 : Developing Concept 2	34
Image 34 : The base chassis has foldable arms containing the propellers.	37
Image 35 : The main components of the design	38
Image 36 : A single chassis can be used for various different form of the fuselage as per the requirement	39
Image 37 : Main chassis design. It has the landing gears and rotors along with propellers in one single unit	40
Image 38 : Main chassis design - main parts	41
Image 39 : Main chassis design - Expanded view	42
Image 40 : Battery Pack (reference image)	43
Image 41 : U15-KV100 Motor (reference image)	43
Image 42 : Interior of the Helicopter	44
Image 43 : Model - fuselage and Chassis	45
Image 44 : Model - fuselage and Chassis	46
Image 45 : Main body of the final Prototype (In progress)	47
Image 46 : Door opening mechanism in Toyota Yui (reference images)	48
Image 47 : easy access to rear seat on Jeep Wrangler (reference images)	49
Image 48 : Folding arm mechanism (reference images)	49
Image 49 : Folding propellers mechanism (reference images)	49
Image 50 : Dimensions	50
Image 51 : Rendered image of Completed model	53
Image 52 : Rendered image of Completed model	54
Image 53 : Completed model using MDF.....	55
Image 54 : Completed model using MDF.....	56
Image 55 : Final Chassis model	57