



Project 3

# Design of a Transformable E-motorcycle for 2035

by  
Niketh SJ  
176390002  
Guided by Prof. Sugandh Malhotra

Mobility & Vehicle Design 17-19  
IDC School of Design  
IIT Bombay



**'transform'** - *"to change the appearance or character of something or someone"*,

**'transformability'** is the ability to undergo said transformation.

# Motivation

- Motorcycles – symbol of speed, freedom, rebellion, personal expression
- Evolution of different types of motorcycles over the years – based on riding style
- Riders adapt to the ride
- Customizability and personalization – key components for products
- Why cant the ride adapt to the rider?
- Why cant the same ride change according to riding conditions and requirements?
- Ride modes – not just change in power settings, but translated physically – new experience

- 
- **Research**
  - **Scenario**
  - **Design Brief**
  - **Concepts**
  - **Final Design**



- **Research**

- Evolution of types, Ride ergonomics. Trend study – styling & tech.

- Scenario

- Design Brief

- Concepts

- Final Design

## 1885 - Daimler Reitwagen

- First motorcycle – first with IC engine
- Wooden frame, wooden wheels with iron ring, belt drive



## 1968 – Yamaha DT 1

- First dual-sport motorcycle
- Higher ground clearance, long travel suspension, bash plate under the engine, lightweight, etc



## 1976 – BMW R100 RS

- First sports tourer motorcycle
- Sporty riding posture, fairing, high windshield



## 1983 – Honda VF750 F

- First faired sport bike – available for the masses
- Based on the legendary CB750



## 1950s – Café racers

- Custom made by enthusiasts in UK
- Racing from café to café
- Built for speed



## 1971 – Harley FX Superglide

- First cruiser
- Developed for long rides comfortably
- Laid back seating, high handles



## 1980 – Honda GL 1100

- 'Goldwing' – full dress tourer
- Revolutionized touring
- Larger tank, laid back seating, increased storage space



## 1980 – BMW R80GS

- First adventure tourer
- Shaft driven



## 6 major segments



Standard

Urban commuter,  
Street naked, Retro  
classic, etc



Cruiser

Power cruiser,  
Bobber, etc

Relaxed

Standard

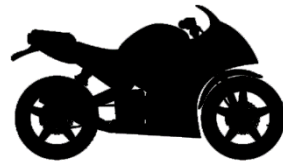

Sport

Super sport, Café  
racers, Naked  
sport, etc

Racing

Café racer



Dual sport

Scramblers, Enduro,  
Adventure, etc

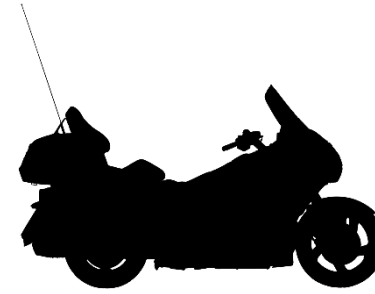

Touring

Sport tourers, Full  
dressed tourers, etc

Off-road

Adventure



Dirt

Trail, Supermoto,  
Motocross,  
Grasstracker, etc

# Ride Ergonomics

## Standard

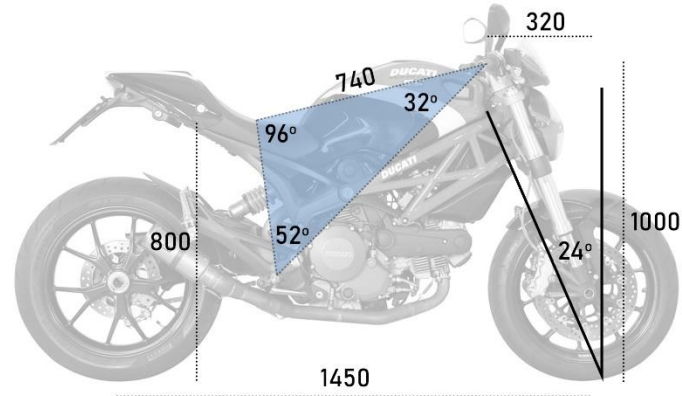

Ducati Monster 796

## Café racer

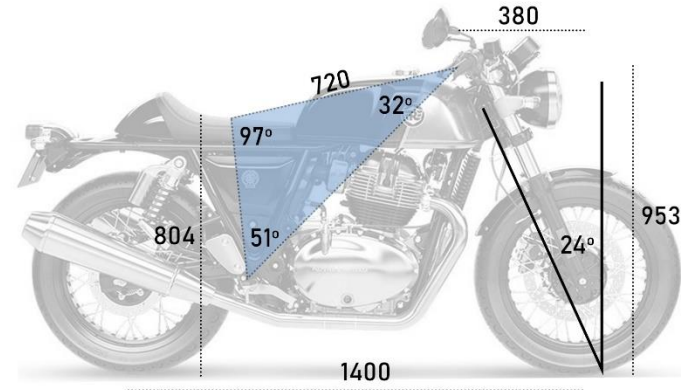

RE Continental GT 650

## Adventure

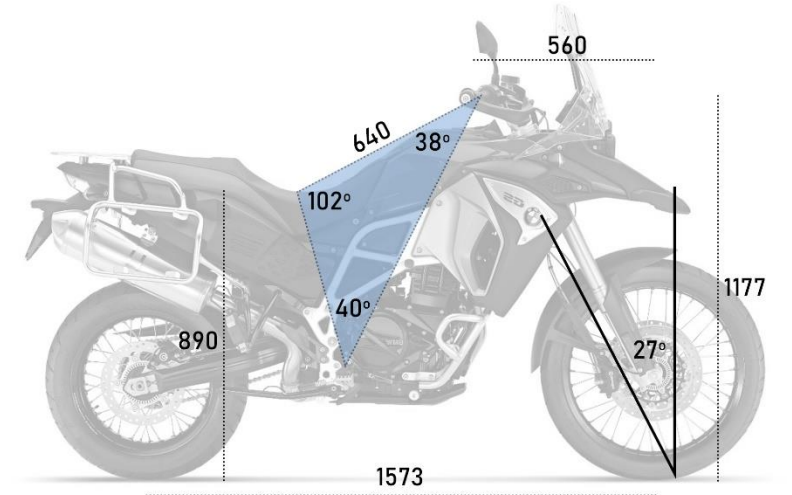

BMW F-750GS

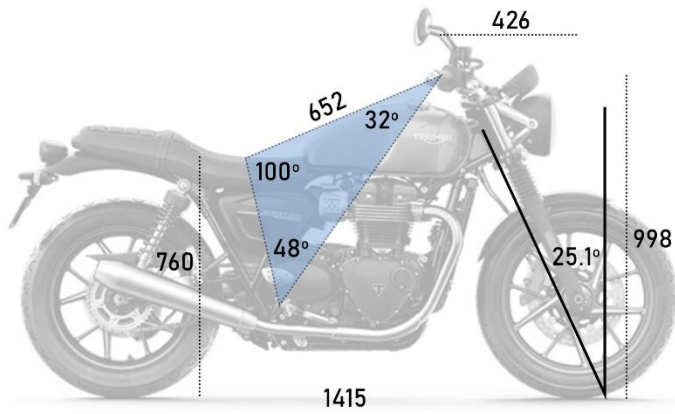

Triumph Street twin

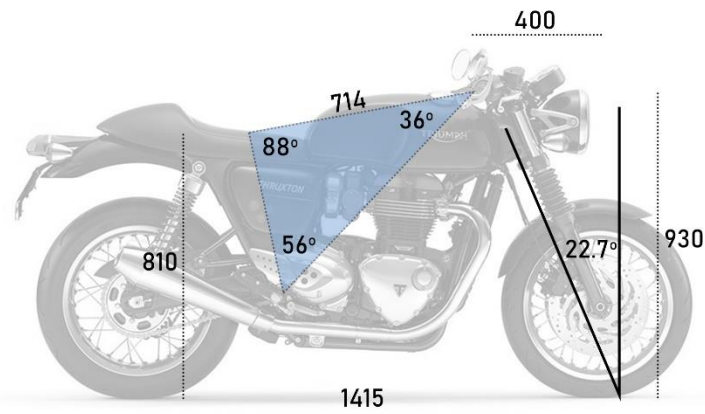

Triumph Thruxton

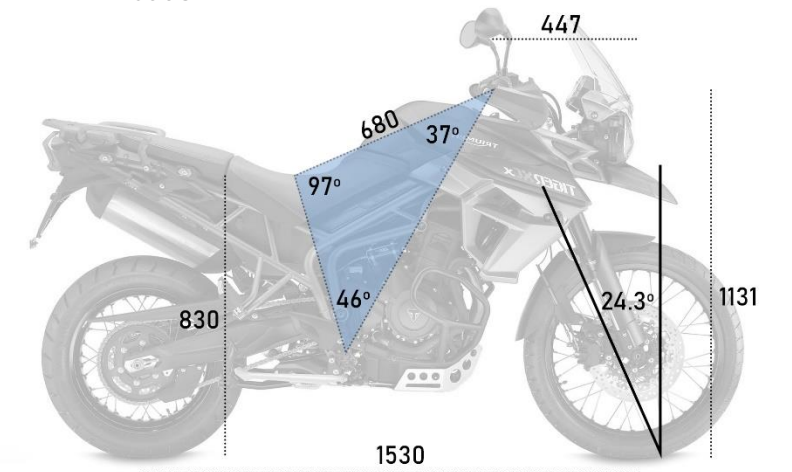

Triumph Tiger 800XCX



Zec00 (2012)



Johammer J1 (2014)



Honda NM4 Vultus (2014)



BMW Motorrad Vision Next 100 (2016)



Yamaha Motoroid (2017)

New volumes

Unconventional silhouettes

Redefining the look of a motorcycle



Renald Grand Tourer (2010)



Lotus C01 (2014)



SIV Katana (2018)

Retro-futuristic styling

Centred around a strong central volume



Yamaha PES1 (2013)



Harley Livewire (2014)



Honda SBM (2017)



Arc Vector (2018)

Conventional volumes, but with new features and novel styling

Stronger and sharper lines demarcating surfaces



Honda CB125M (2018)



BMW Motorrad 9cento (2018)



Husqvarna Vitpilen 701 Aero (2018)



Husqvarna Vitpilen 701 (2018)



Confederate P51 (2015)



AP Works Lightrider (2018)



Curtiss Zeus (2018)

Highly unconventional silhouette and styling

Raw analogous feel to the design

Unconventional packaging

A decorative background on the left side of the page consisting of overlapping, semi-transparent blue polygons of various shapes and sizes, creating a low-poly or crystalline effect.

## Technological trends

Advanced manufacturing processes

New materials

Alternative energy sources

Ride assist

Self balancing

AI integration

Advanced safety features

Ride mode selection

Alternate steering methods

Intelligent riding gear

Autonomy



# Transformability

- Ability to undergo changes to accommodate for functional or aesthetic purposes
- Alteration in geometry
- Majority of concepts use moving components to bring about changes in form and function

## Furniture

- Hidden components shift around to alter function of the product
- Existing components undergo change in orientation to alter function of the product



Clei Doc Sofa-bunk bed



Wave cabinet by Sebastian Errazuriz



BOULON BLANC

Boulon Blanc table

## Products

- Alterable surfaces to change aesthetics of the product
- Function of product can also be altered by change in geometry of the surface



Limbo smartphone



Nokia 888 concept



D'Light Kinetic Lighting

## Architecture

- Shifting walls/rooms change the façade of the structure and interior spatial experience too
- Intelligent shading – reduces dependency on artificial lighting – power savings



Sharifi-ha House by Next Office

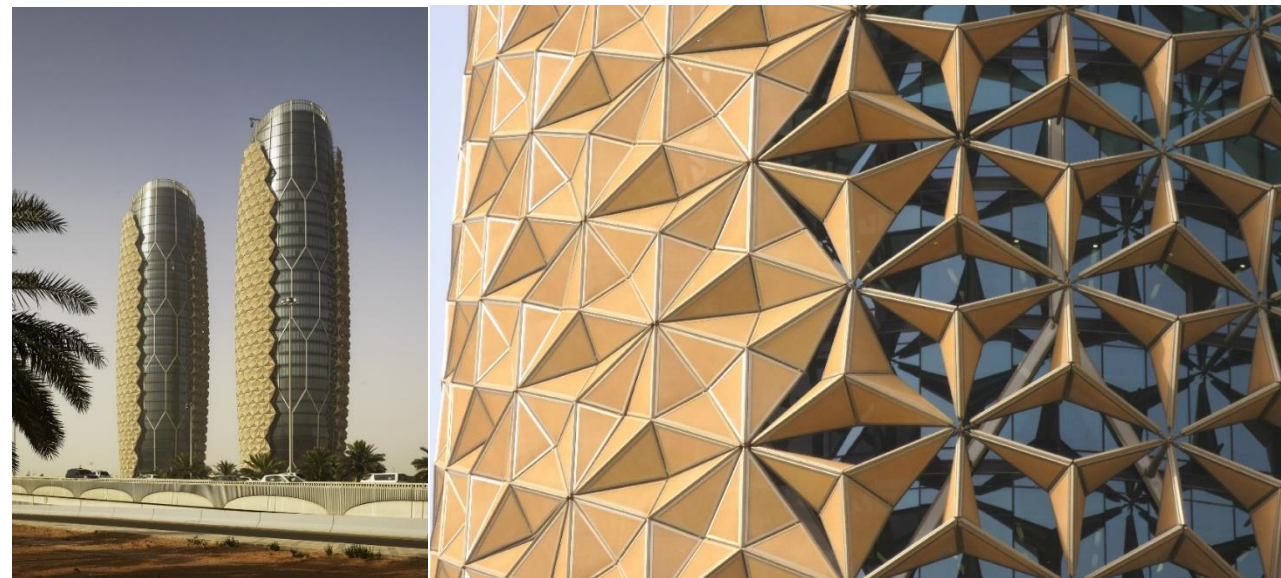

Al Bahr Towers by Aedas Architects

## Architecture

- Structures open out to change the entire look of a building
- Transformation mainly used in shading devices – time, weather dependent



# Transformability

```
graph TD; A[Transformability] --> B[Collapsible or movable mechanisms]; A --> C[Surfaces itself shift around to undergo transformation]; B --> D[Mechanical folding systems]; B --> E[Origami inspiration]; B --> F[Nanotech - self assembly, foldable robots]; C --> G[Shape memory polymers]; C --> H[4D materials];
```

**Collapsible or movable mechanisms**

**Mechanical folding systems**  
**Origami inspiration**  
**Nanotech - self assembly, foldable robots**

**Surfaces itself shift around to undergo transformation**

**Shape memory polymers**  
**4D materials**



- Research

- **Scenario**

- 2035: Context, Product, User, Transportation, Story

- Design Brief

- Concepts

- Final Design

## 2035

- Nations aiming to completely switch to electric automobiles by 2030 – 2035 E-vehicles will become very common
- Technology advances exponentially – feasibility of introducing transformable product – AI, active surfaces, advanced manufacturing processes and materials

# 2035: The context

- 8.8 billion people ([United Nations, Population of the world](#))



# 2035: The context

- 8.8 billion people ([United Nations, Population of the world](#))
- 60% of global population in urban setting ([United Nations](#))



# 2035: The context

- 8.8 billion people ([United Nations, Population of the world](#))
- 60% of global population in urban setting ([United Nations](#))
- Evolution of megacities ([World Economic Forum](#))



# 2035: The context

- 8.8 billion people ([United Nations, Population of the world](#))
- 60% of global population in urban setting ([United Nations](#))
- Evolution of megacities ([World Economical Forum](#))
- High dependence on clean energy ([Wood Mackenzie](#))



# 2035: The context

- 8.8 billion people ([United Nations, Population of the world](#))
- 60% of global population in urban setting ([United Nations](#))
- Evolution of megacities ([World Economical Forum](#))
- High dependence on clean energy ([Wood Mackenzie](#))
- Biomimicry and nature inspire majority of products ([Guile Hutchins](#))



# 2035: The context

- 8.8 billion people ([United Nations, Population of the world](#))
- 60% of global population in urban setting ([United Nations](#))
- Evolution of megacities ([World Economical Forum](#))
- High dependence on clean energy ([Wood Mackenzie](#))
- Biomimicry and nature inspire majority of products ([Guile Hutchins](#))
- Rise in use of public transport for commute – public transport becomes faster and cheaper



# 2035: The context

- 8.8 billion people ([United Nations, Population of the world](#))
- 60% of global population in urban setting ([United Nations](#))
- Evolution of megacities ([World Economical Forum](#))
- High dependence on clean energy ([Wood Mackenzie](#))
- Biomimicry and nature inspire majority of products ([Guile Hutchins](#))
- Rise in use of public transport for commute – public transport becomes faster and cheaper
- All systems interconnected

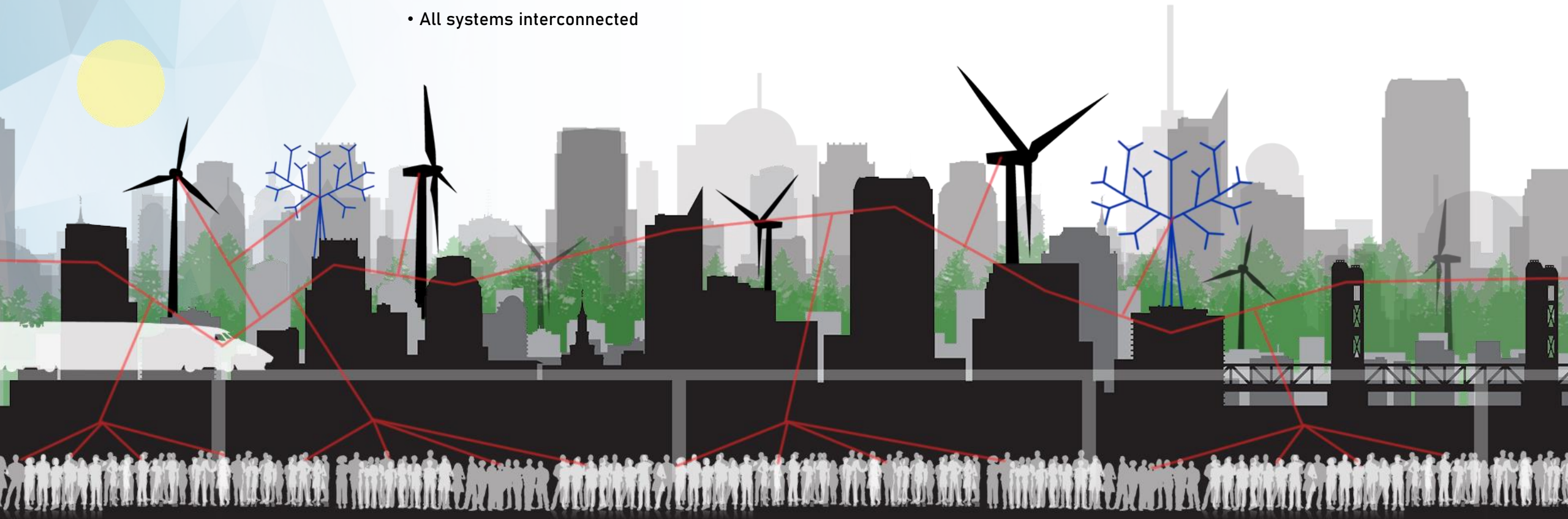

# 2035: Products

- High level of customizability and personalization in products – pre production and post production customization ([Kabasakal Inang](#), [Mckinsey](#))
- IOT enabled and always connected, smart products
- Advanced AI enabled products become available – products with ability to converse with the user
- Products become extension of user and his personality
- Open source files available for user to customize and print own products
- Advanced materials – self healing, 4D printed, intelligent
- Biometric security, smart keys, etc ensures product security

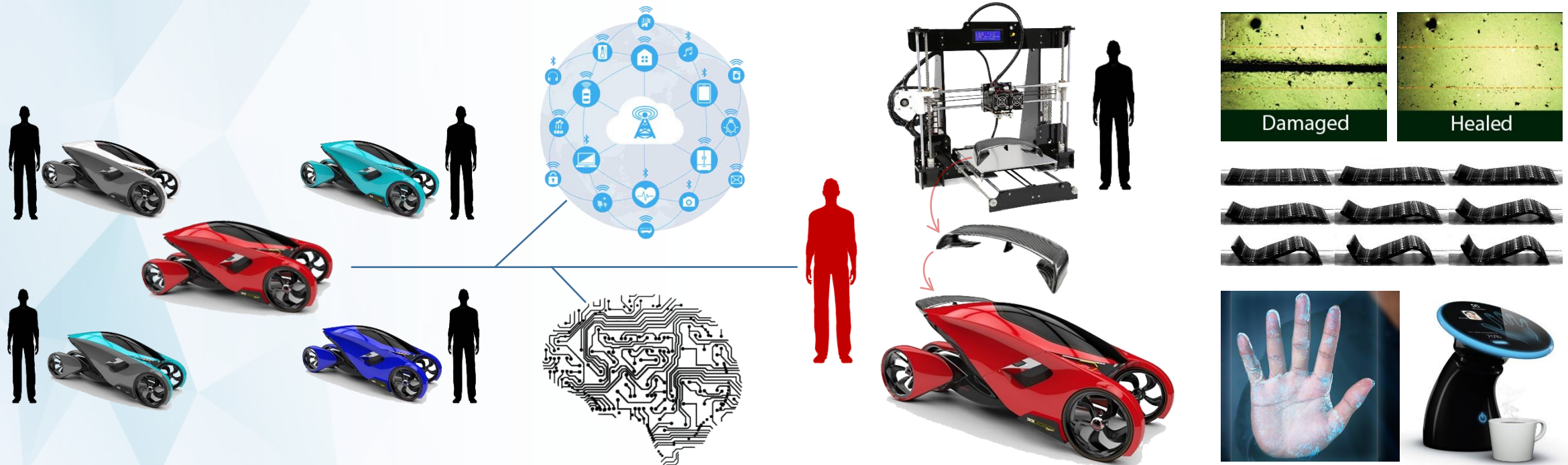

# 2035: The user

- Rise in unmarried population ([Journal of future studies](#), [CQRResearcher](#))
- Implants become common – health, diet monitoring, enhancement implants, etc ([Schulz, Benjamin](#))
- IOT enabled smart clothing becomes common
- Highly stressed generation ([WHO](#))
- Advanced prosthetics and enhancements
- Tailor-made products available – wants everything personalized
- Life eased by autonomous systems
- Engulfed in an AR-VR-MR environment ([Peter H Diamandis](#))
- High dependency on virtual personal assistants ([Tal, David](#))
- Better brain – computer connection : thought activated commands

↑ Friends with benefits  
Domestic union  
Living together  
Its complicated  
In a relationship  
Single  
Forever alone

↓ Marriage

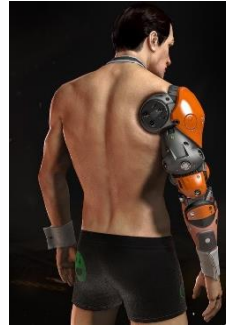

# Future Transportation Concepts

2 wheelers



3 wheelers



Pods

# Future Transportation Concepts

4 wheelers



Aerial approach



# Future Transportation Concepts

Public transport





Jacob | 25 years old

Consulting job  
Sedated by a sterilized lifestyle  
Surrounded by AR/VR

Wants to break out and explore  
Wants to make a statement  
Enthusiastic about riding  
Like to go on adventures  
Unmarried

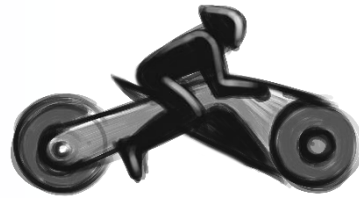
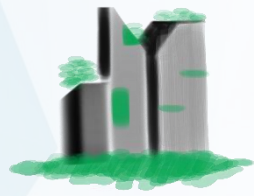

Owns hi-speed motorcycle and uses it for intercity rides, road trips – as part of profession and leisure

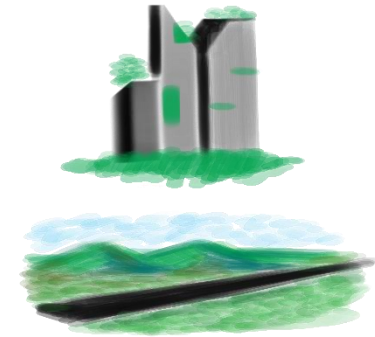

He wants to use it for urban commute  
also, but the ride ergonomics are very  
specific to hi-speed riding





Urban commute involves very regular start-stop situations. On his motorcycle, he finds this highly uncomfortable while commuting

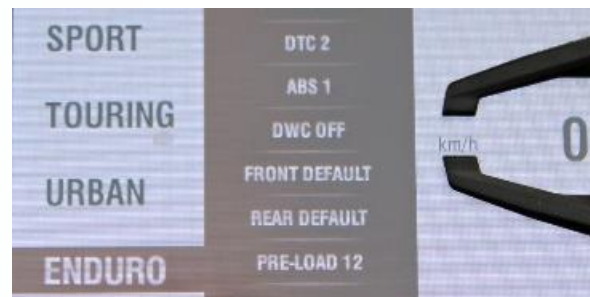

Although there are ride modes, it only alters the power output and suspension settings

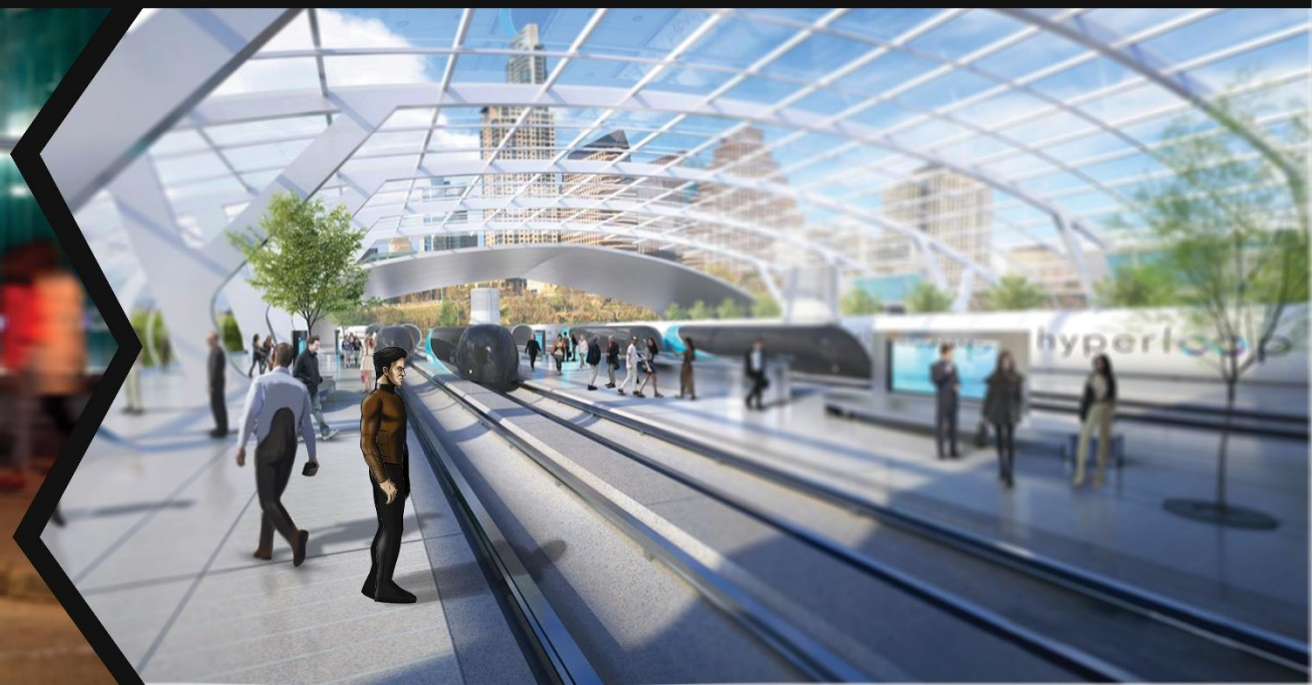
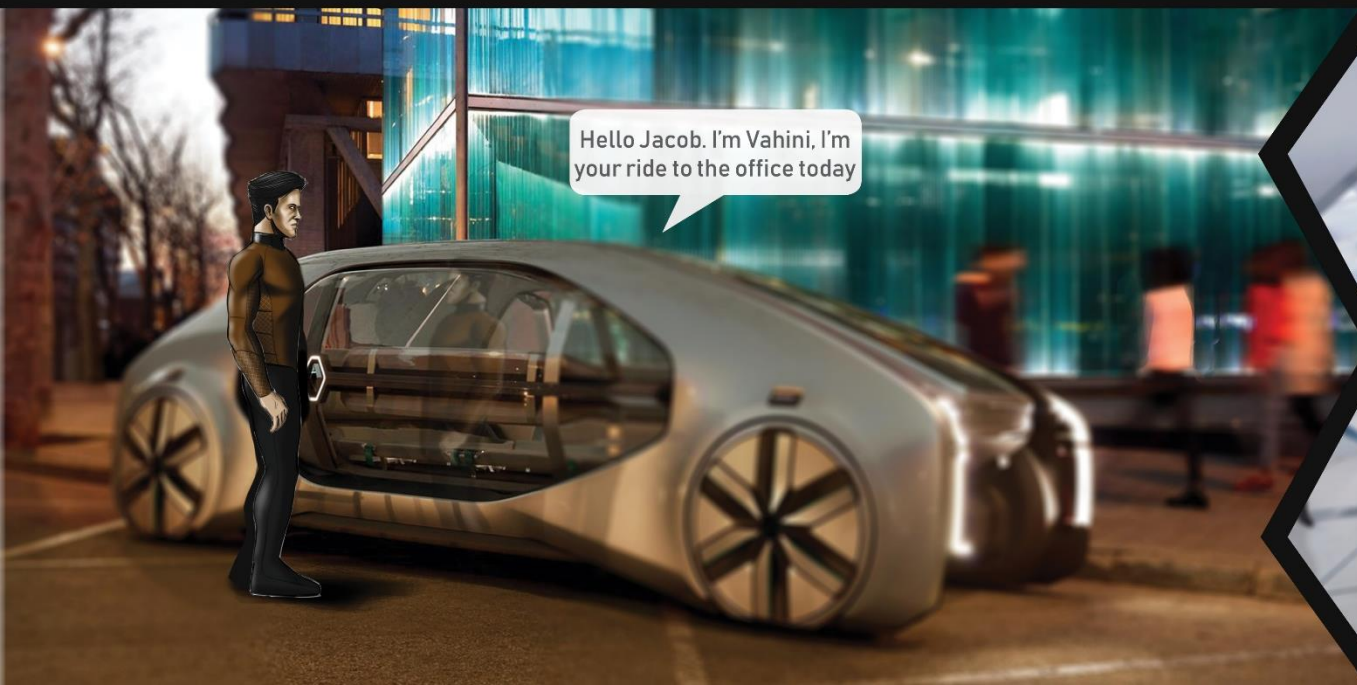

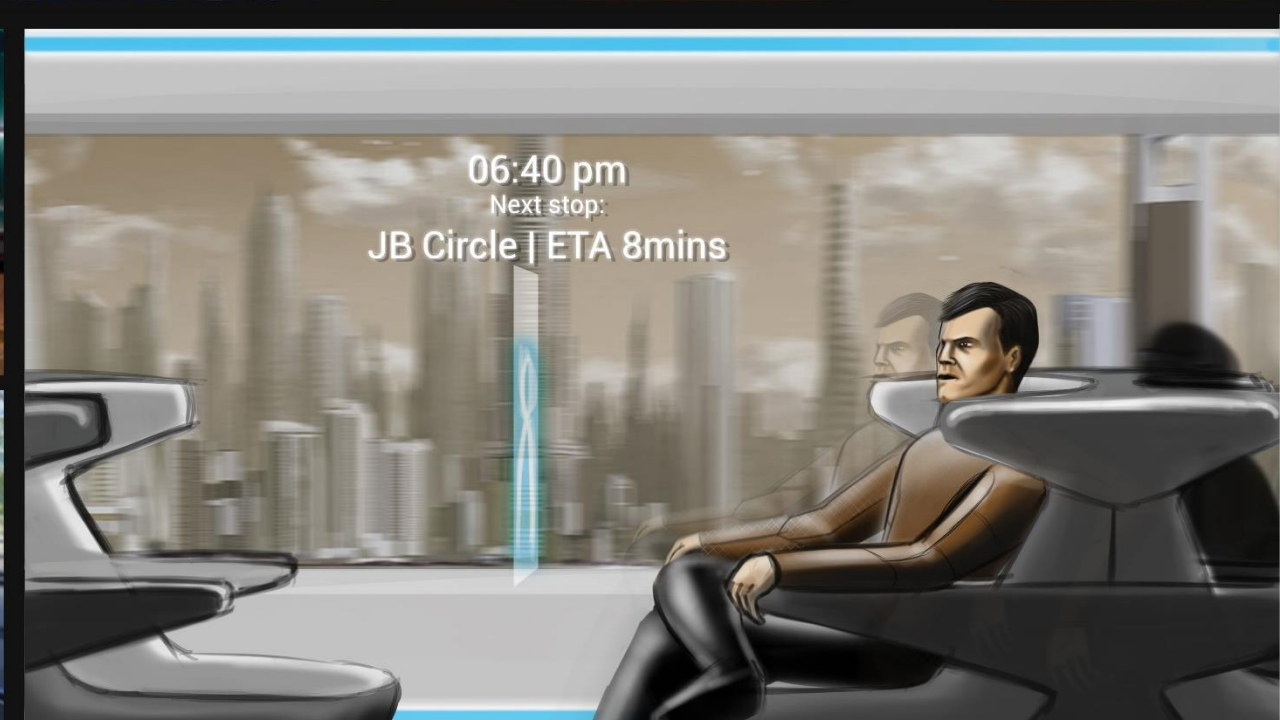
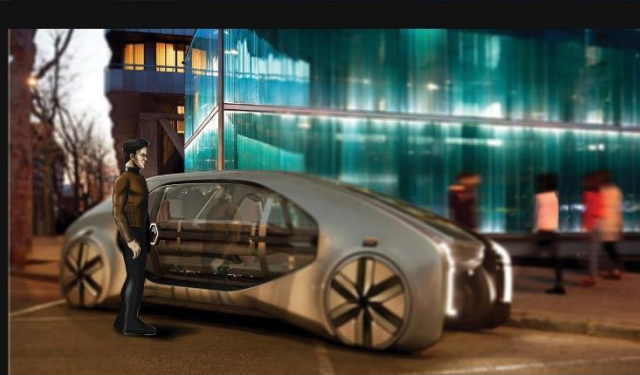

The intervention

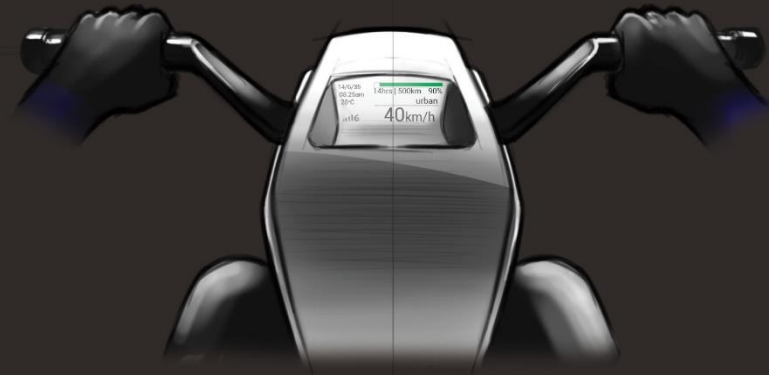
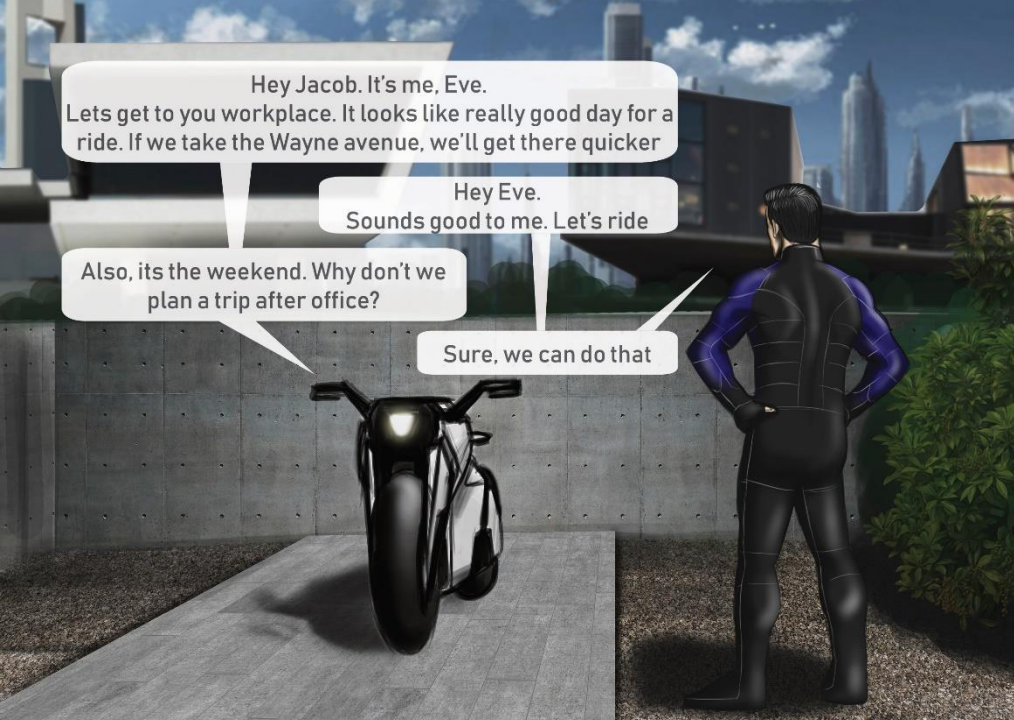

Ride starts up in response to the user.  
 For the urban mode, it has a visually softer surface - calm and relaxed experience given to the user

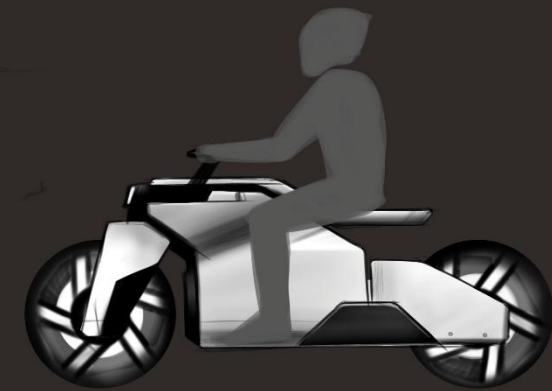

Relaxed seating posture reduces ride fatigue. Allows for more movement and shifting while on the seat



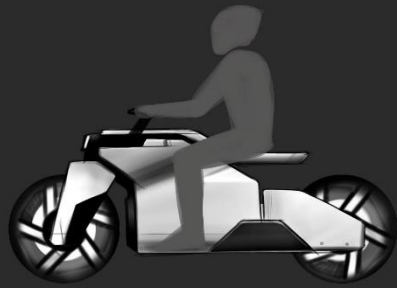

AI responds to voice command and changes the ride mode. The ergonomics change based on preset values according to specific anthropometric dimensions of the rider

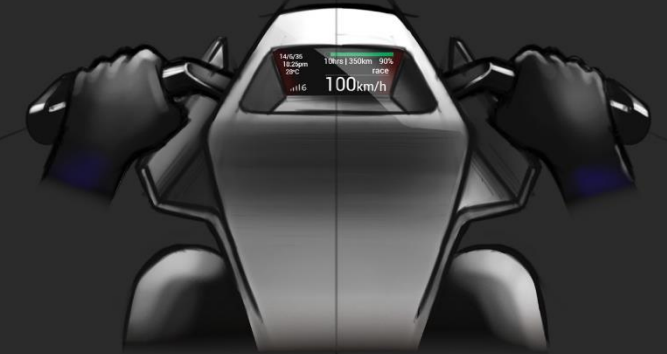

Along with the posture change, the overall ride becomes more aggressive and road hungry in the race mode. Surfaces shift around to give an aggressive and edgier feeling.

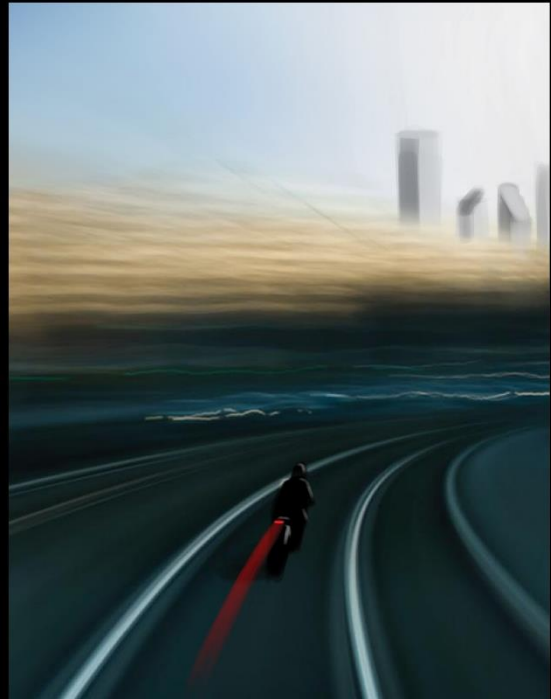
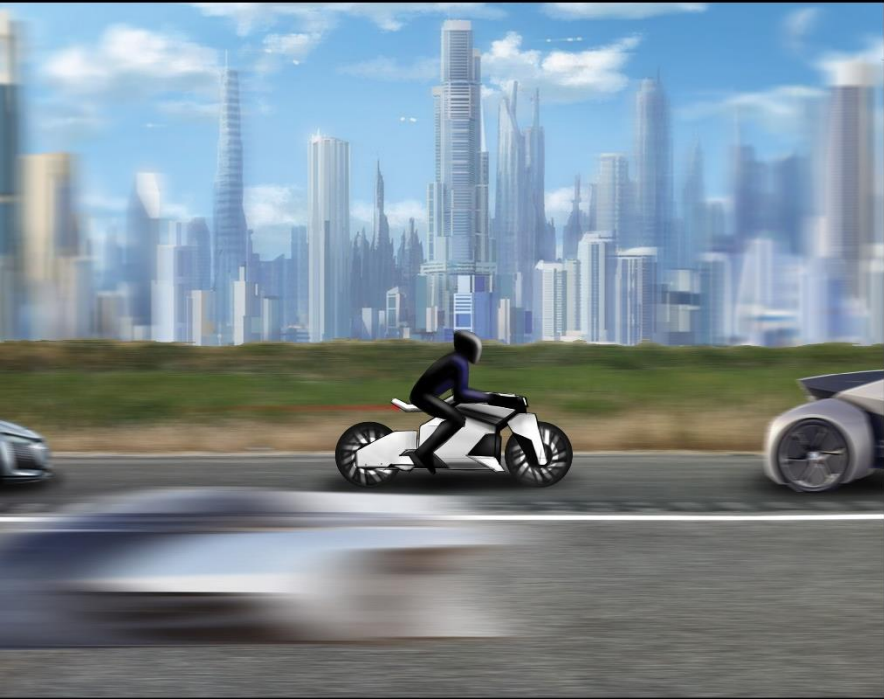

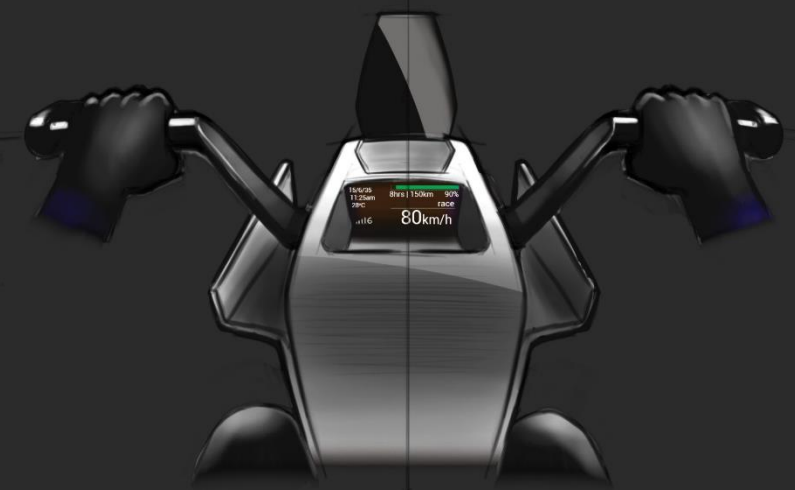
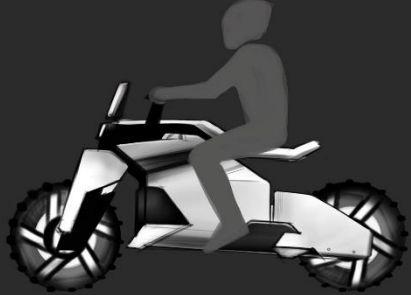
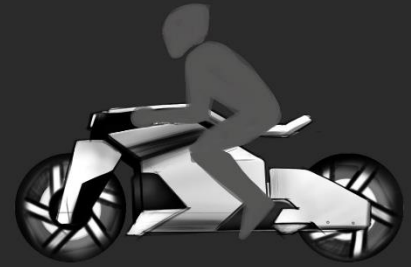
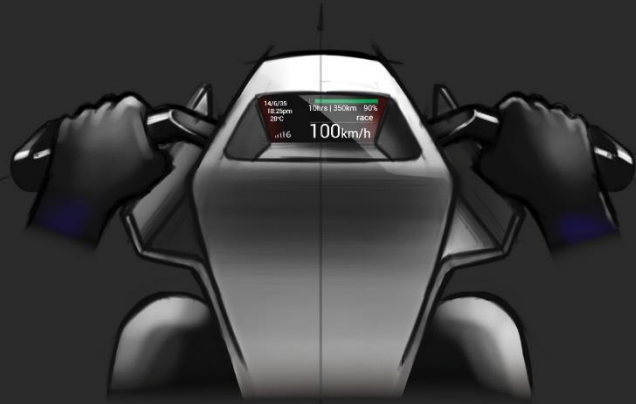

Not only does the mode change affect the ride visually, but the overall ride experience changes. The race mode is more powerful and grippier than the urban mode

In the adventure mode, the ride height changes and the ride transforms into a bulkier machine which can eat up trails and tracks all the while giving pure joy to the rider



Adapts to the rider – ergonomics and ride style

Switches seamlessly between modes – change ride ergonomics

New ride experience for each mode – visually, physically

Physical manifestation of ride modes

- 
- Research
  - Scenario
  - **Design Brief**
  - Concepts
  - Final Design

# Design Brief

- Conceptualize and design a transformable electric motorcycle for a youngster for the year 2035.
- Should be able to alter its geometry to offer multiple ride modes and experiences:
  - Variable wheelbase and ride height
  - Shifting ride posture with alteration in position and geometry of seat
  - Variable handlebar height, width and reach
  - Dynamic changes in geometry of bike to give the visual and physical experience of the transformation or mode change - shift in tank geometry, change in style and look of info-graphic screen.
- The motorcycle will have single seating and is targeted at young professionals working in creative and consultancy fields, living in a metropolitan area in 2035. They enjoy riding a motorcycle for daily commute, take long distance trips as part of work and leisure, and like to go exploring and trail riding whenever they can.
- Exterior design of the motorcycle should reflect the personality and lifestyle of the rider - Edgy and dynamic

# Ride Ergonomics

## Urban

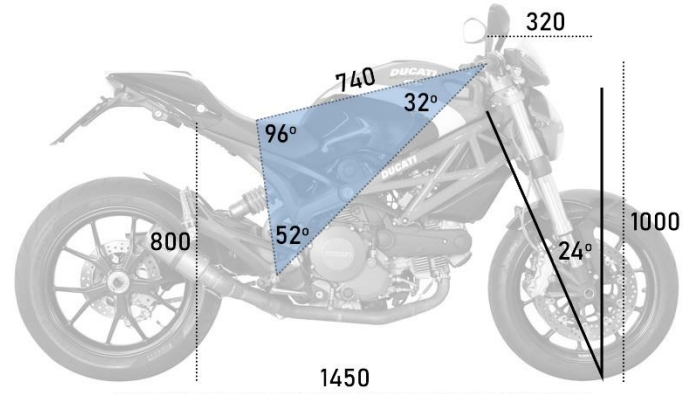

Ducati Monster 796

## Café racer

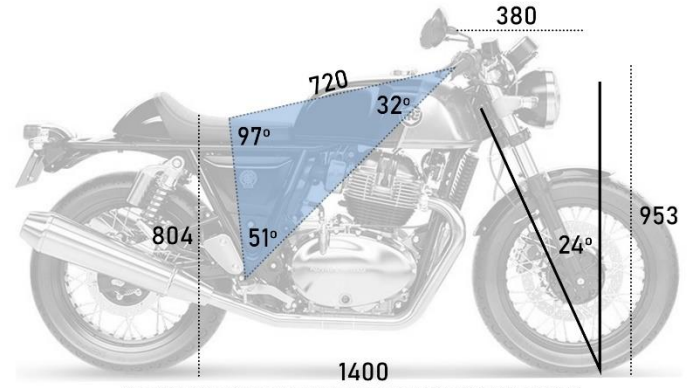

RE Continental GT 650

## Adventure

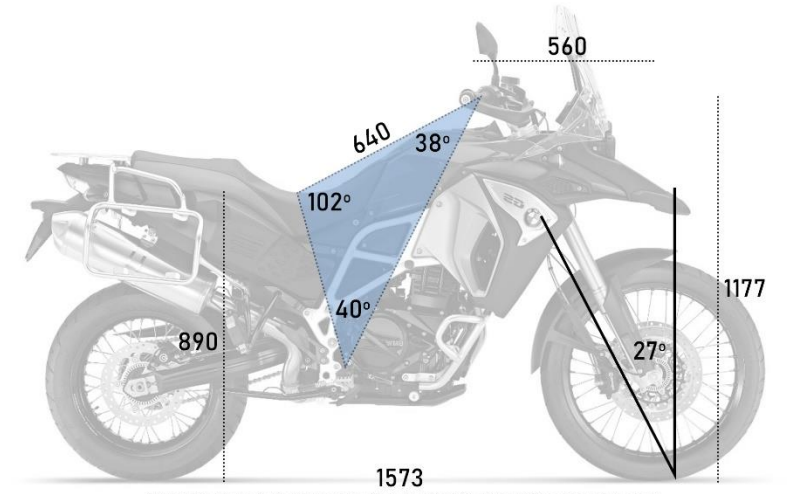

BMW F-750GS

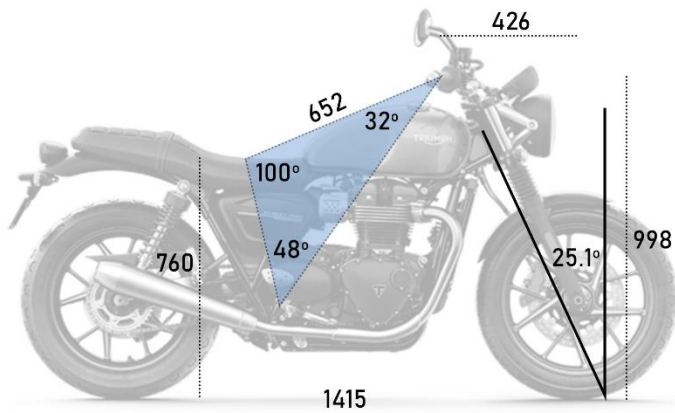

Triumph Street twin

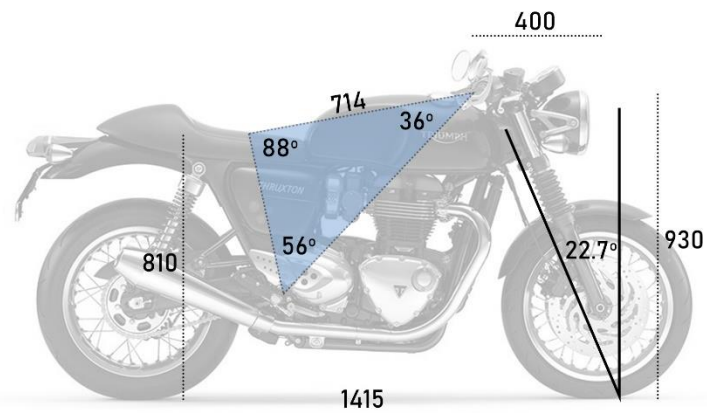

Triumph Thruxton

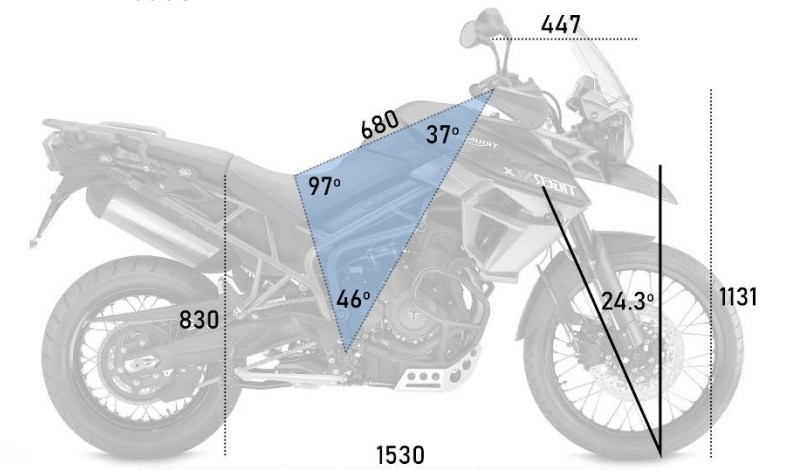

Triumph Tiger 800XCX

# Ride Ergonomics

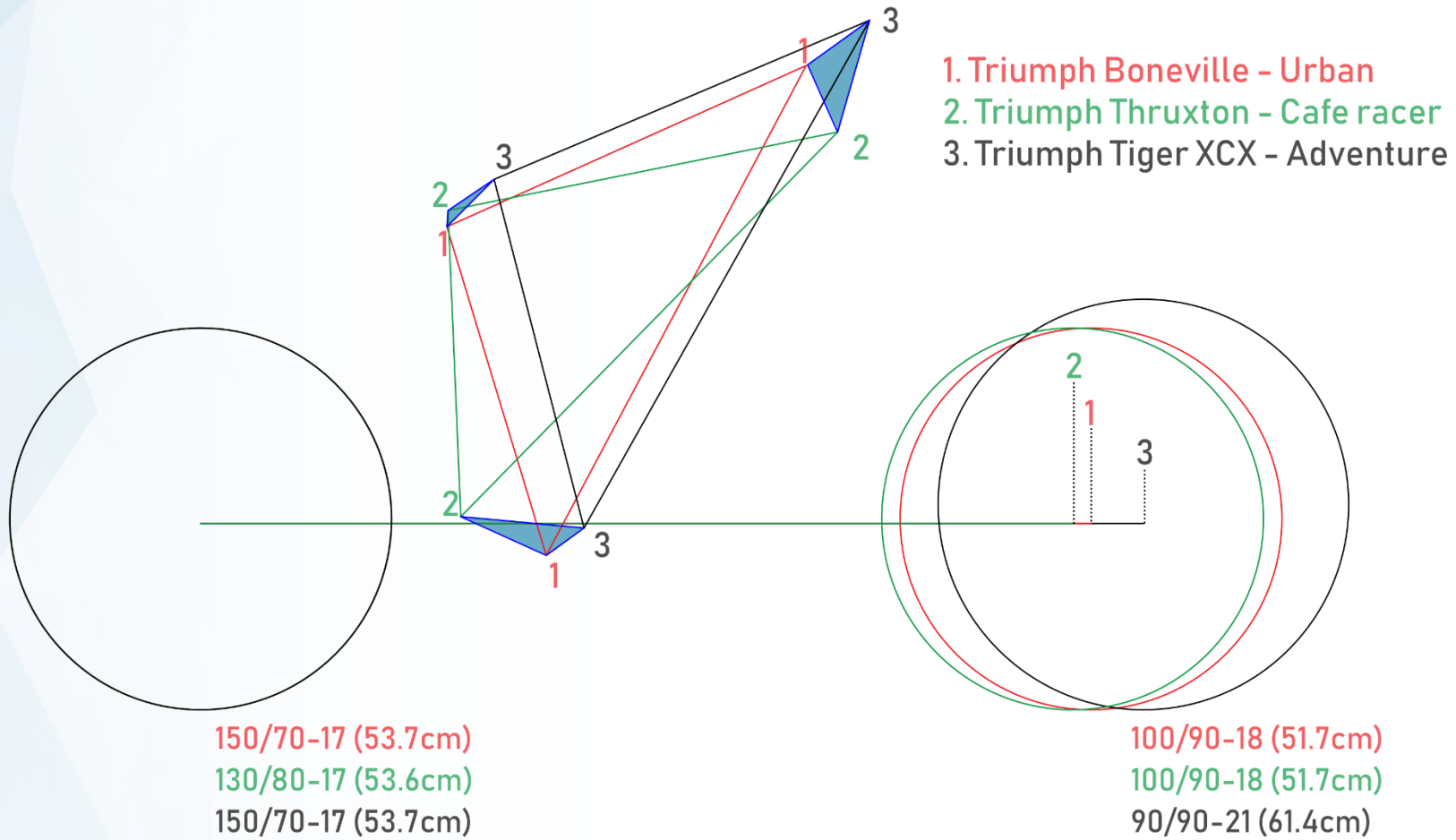



- Research

- Scenario

- Design Brief

- **Concepts**

- Mood board. Ideations.

- Final Design

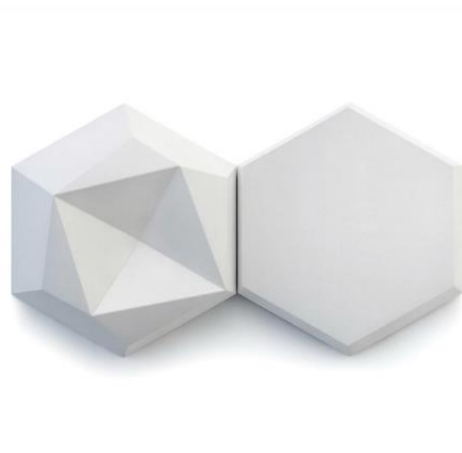
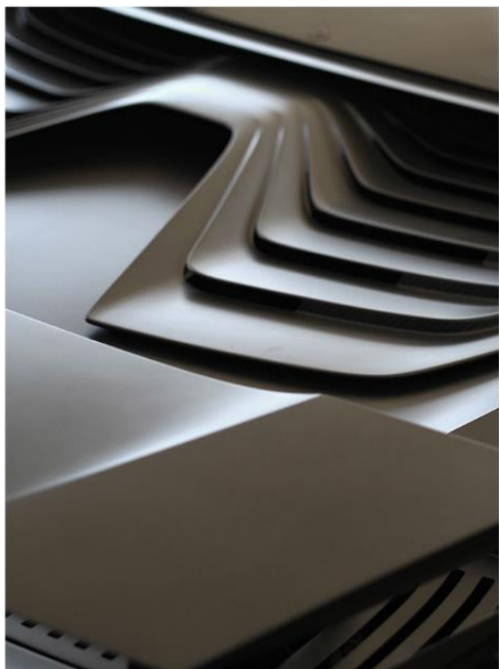
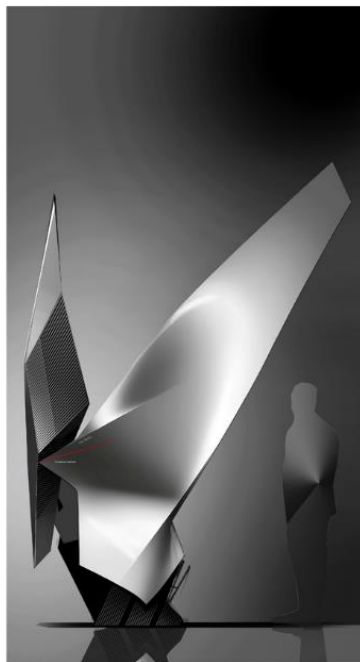
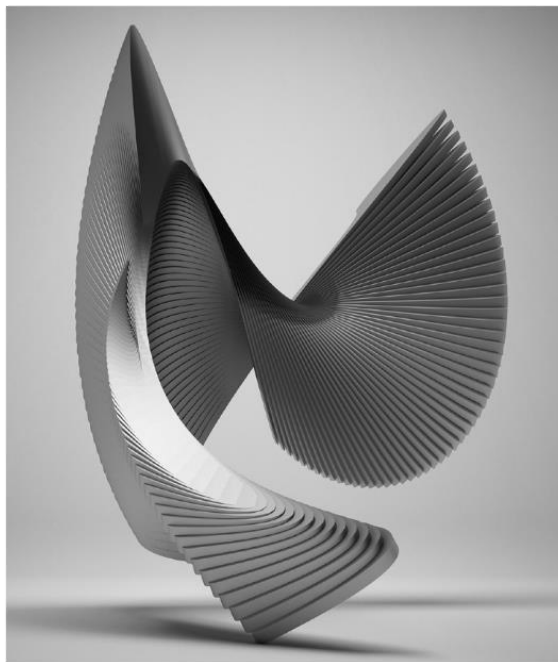
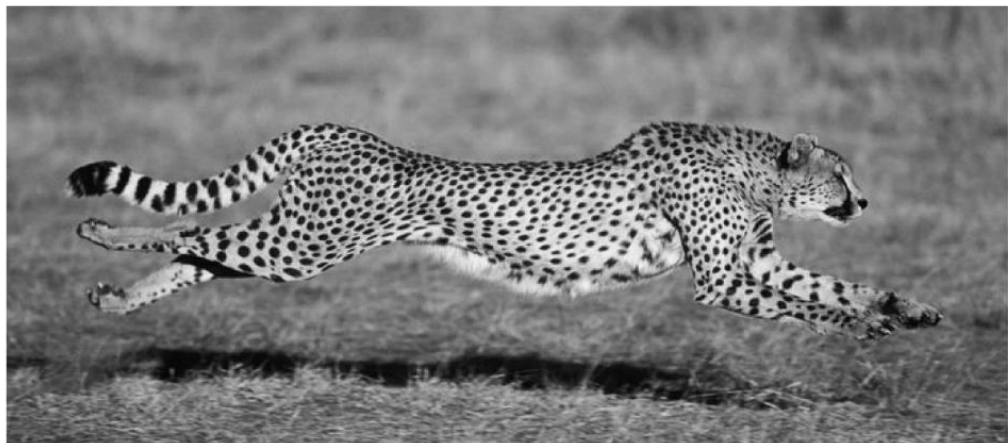

EDGY DYNAMIC



# Ideations

# Concept 1

- Inspiration from biomimicry

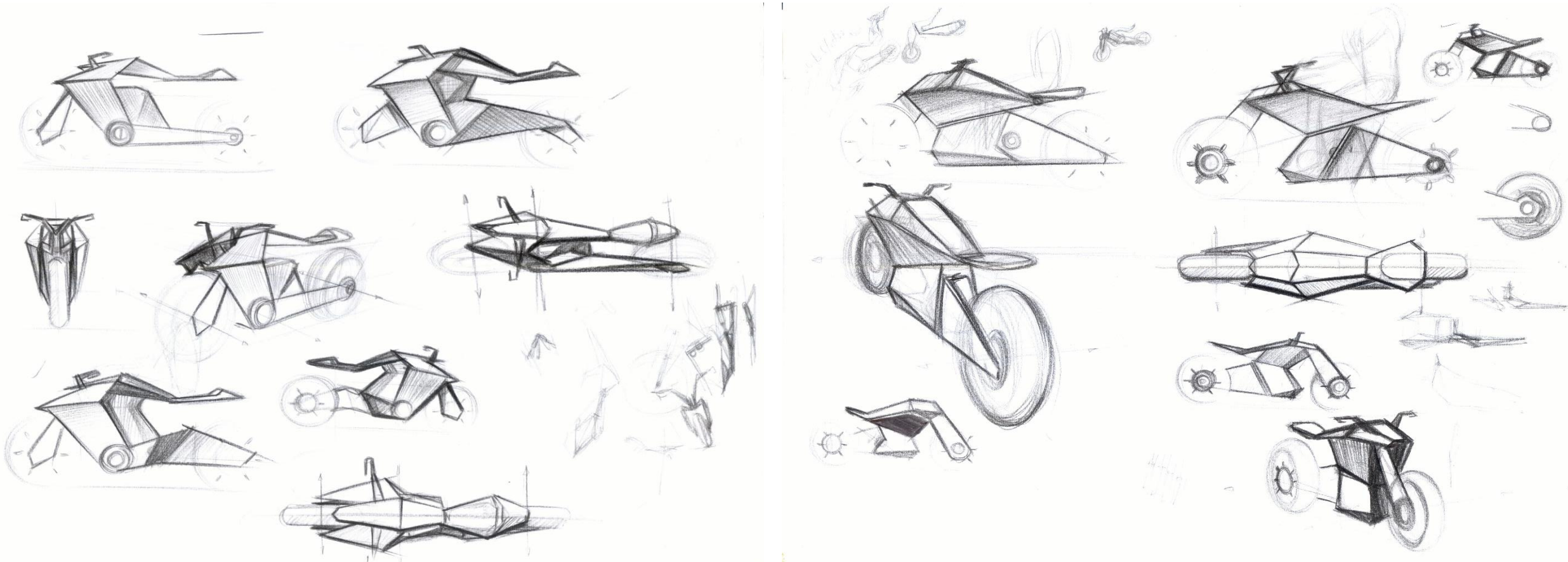
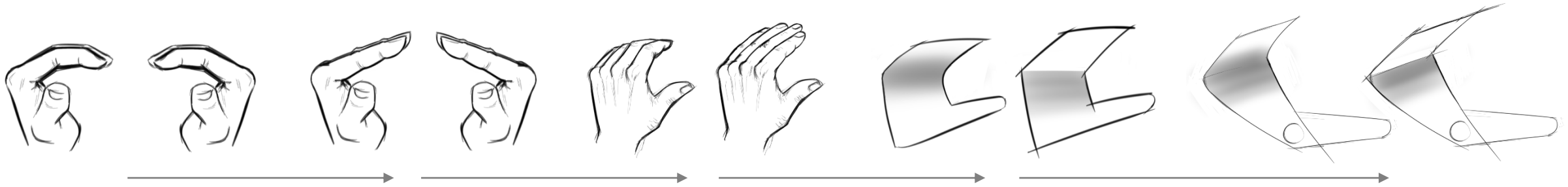

# Concept 1

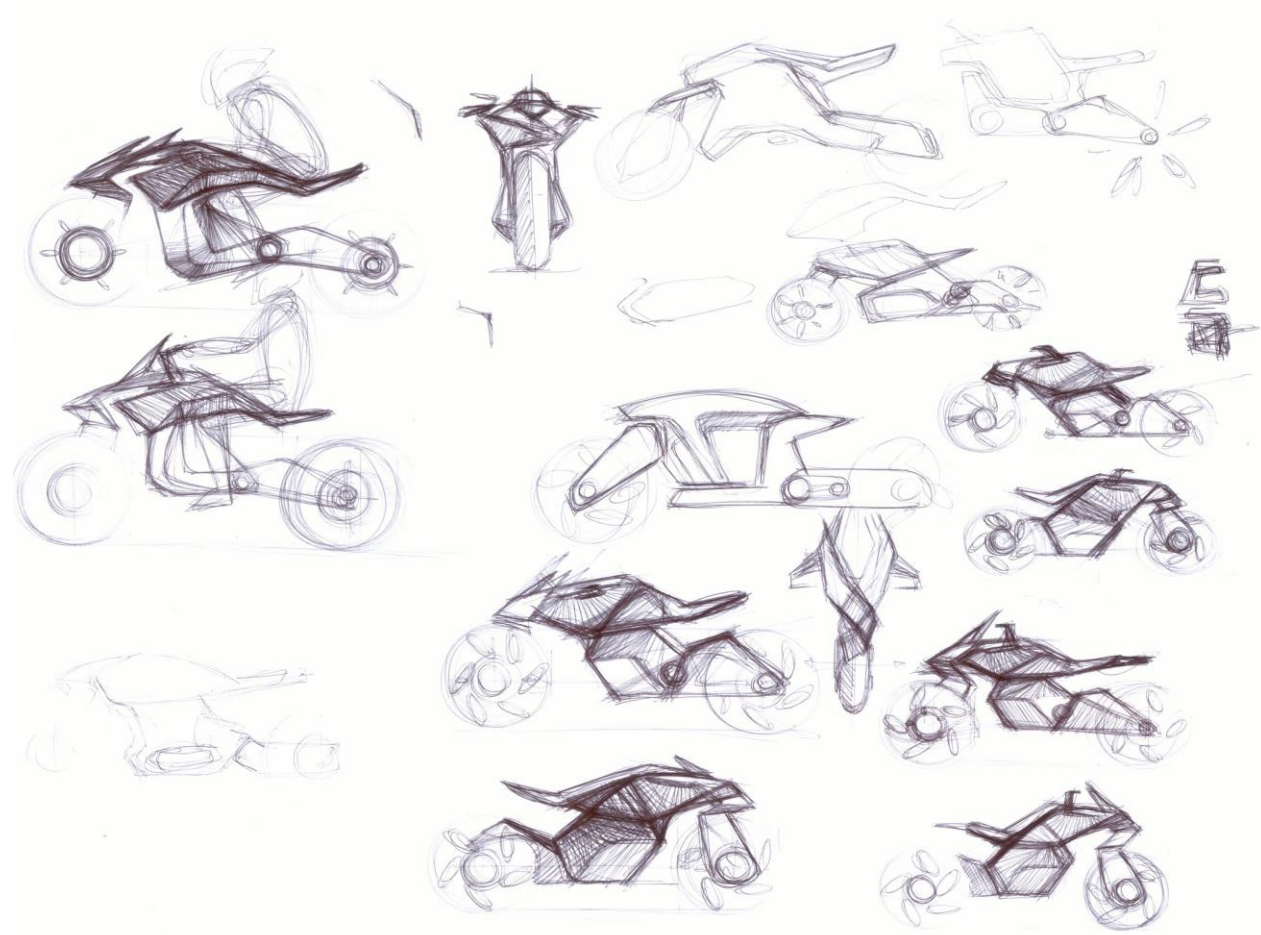
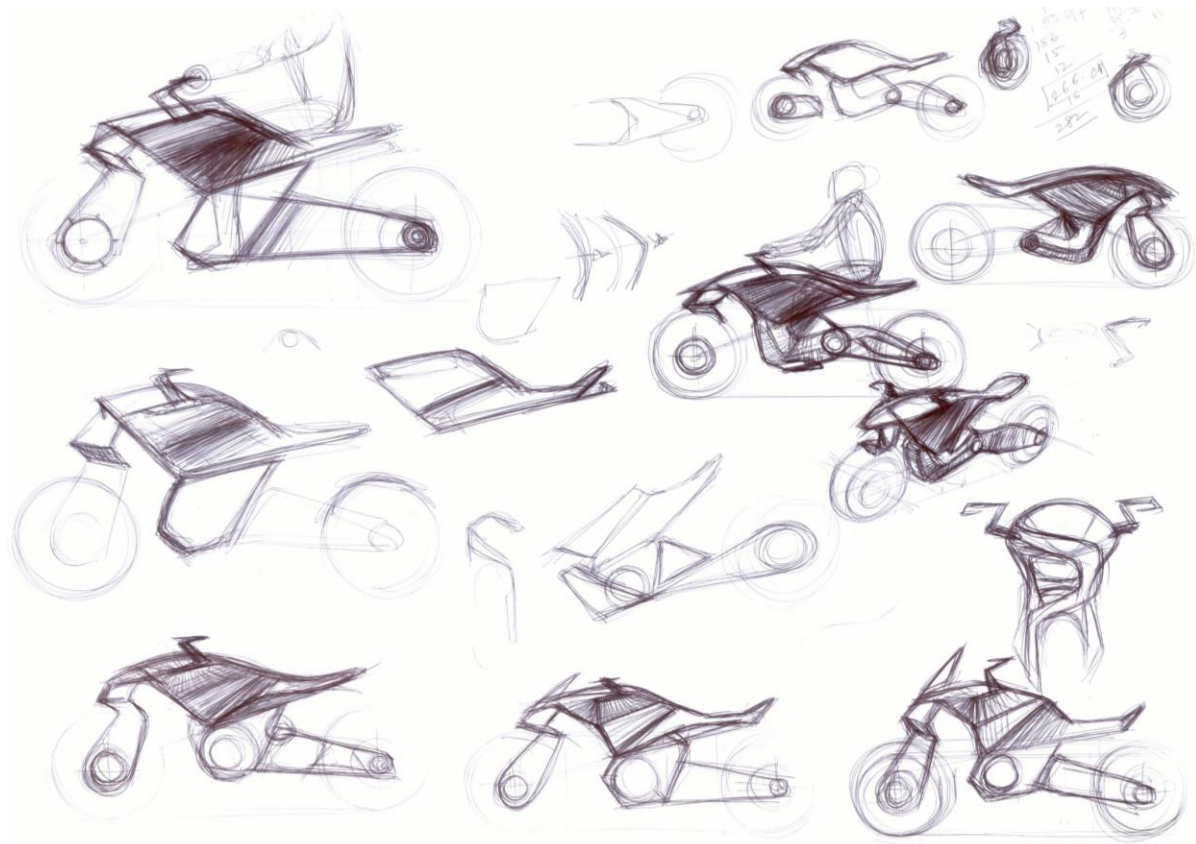

# Concept 1

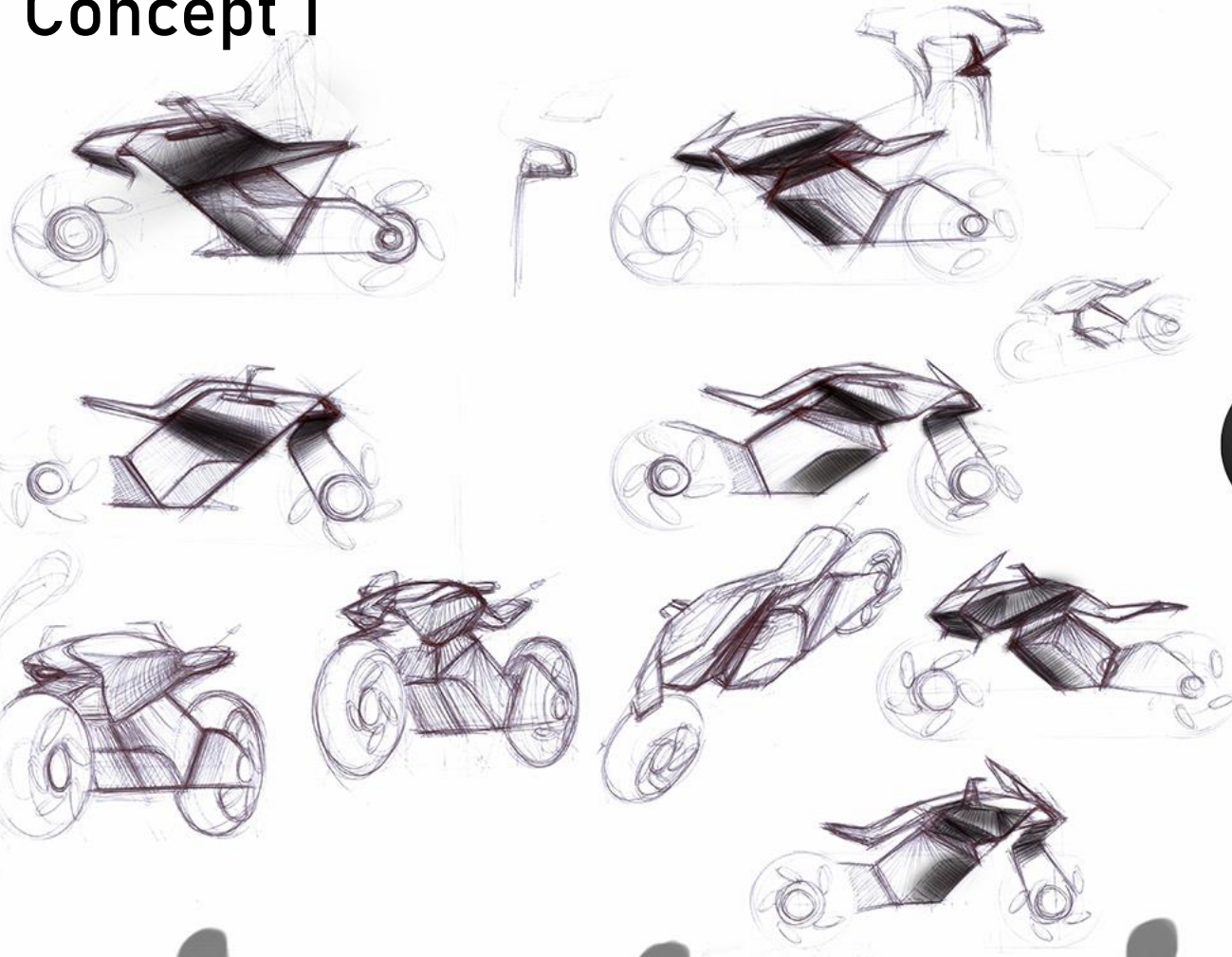

Urban

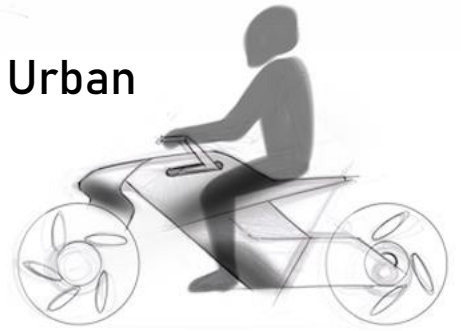

Race



Off-road



ACTIVE SKIN

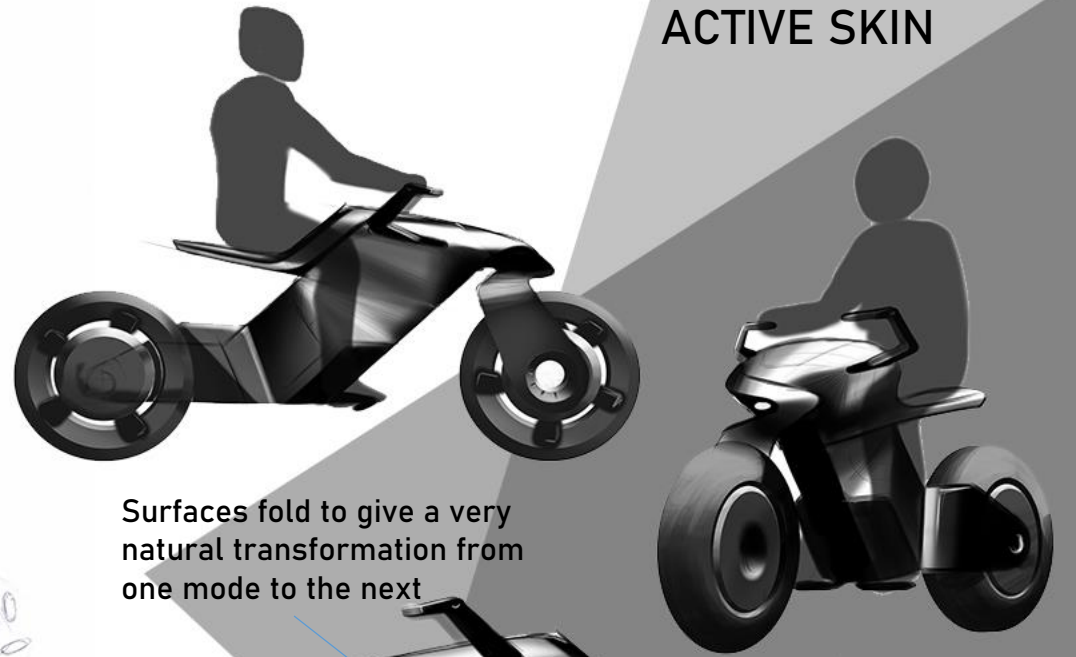

Surfaces fold to give a very natural transformation from one mode to the next

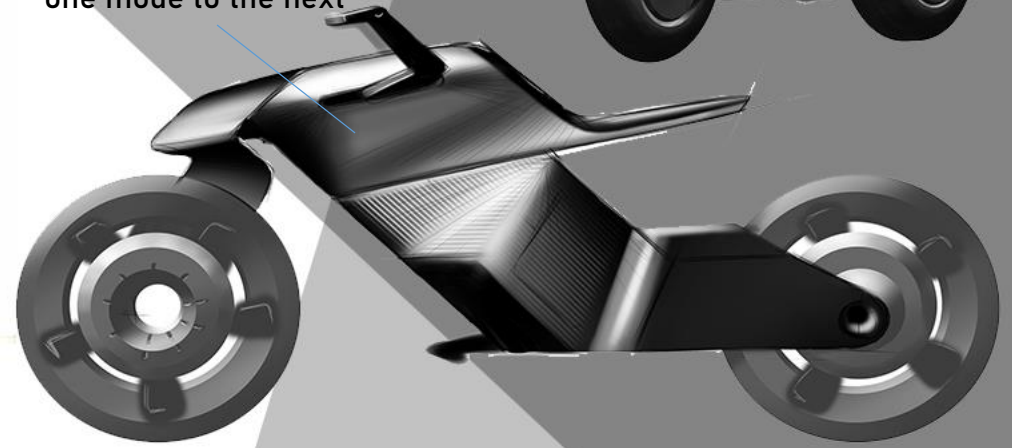

# Concept 2

- Bare bone & naked concept
- Celebrating transformability

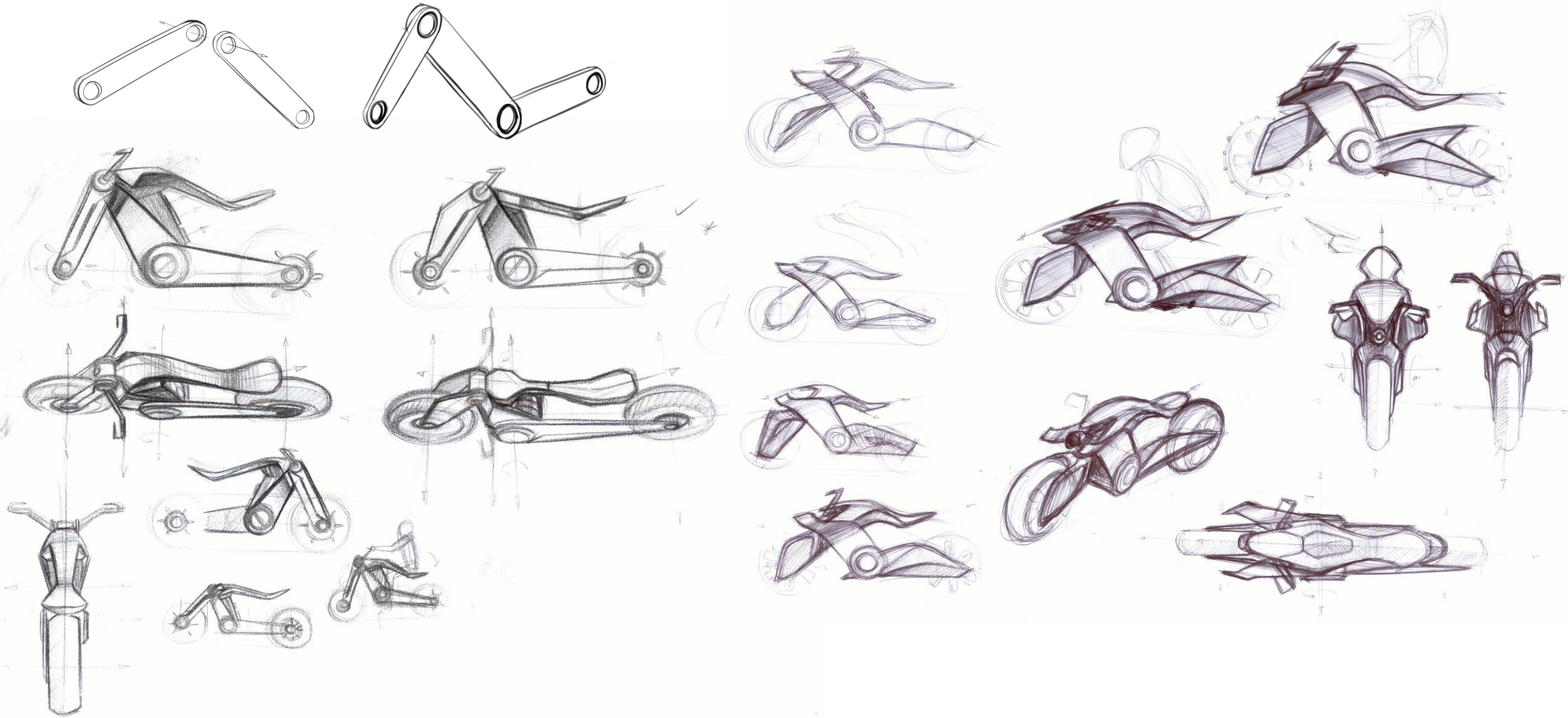

# Concept 2

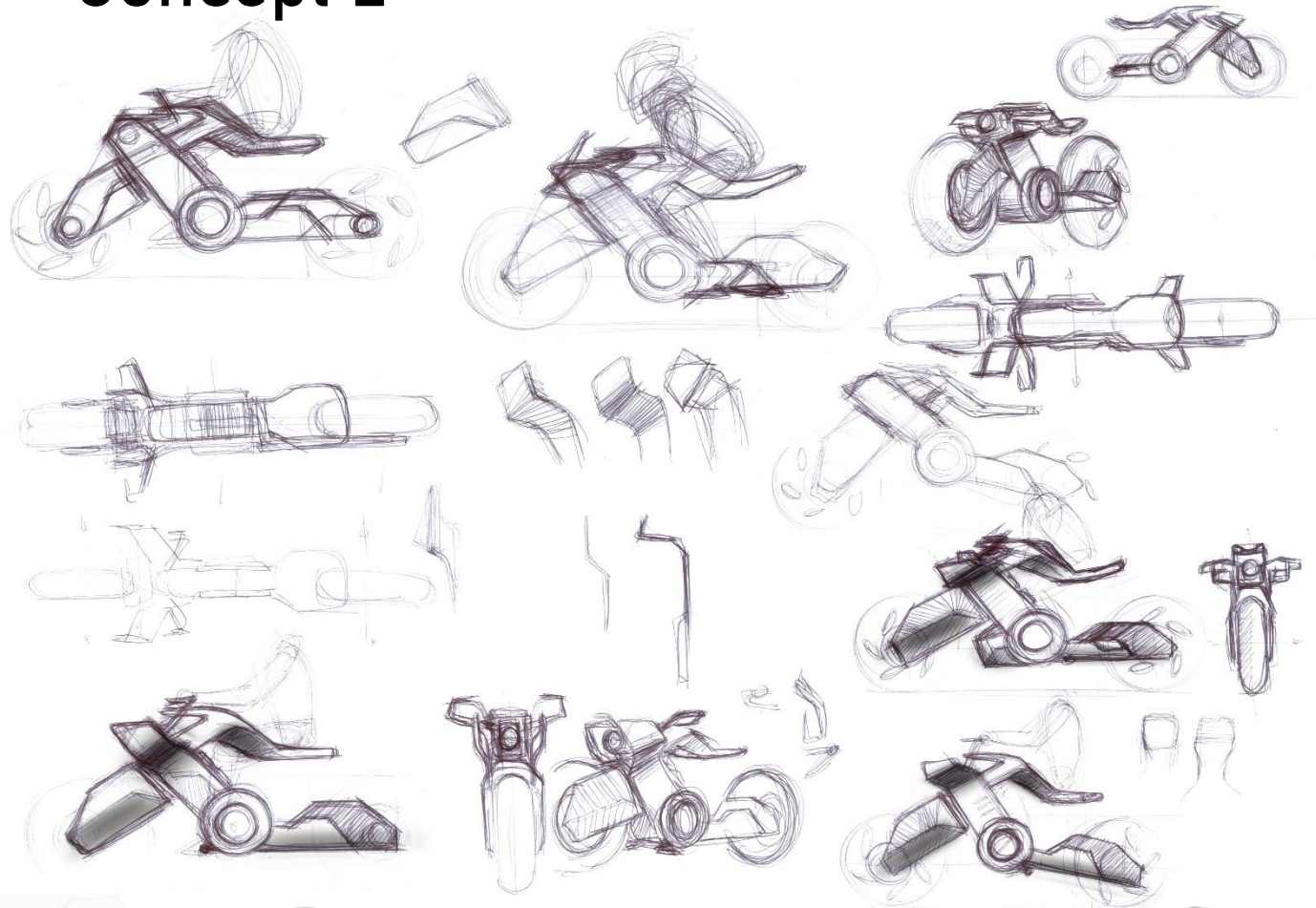

Urban



Race

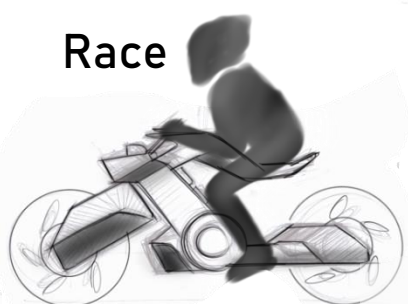

Off-road

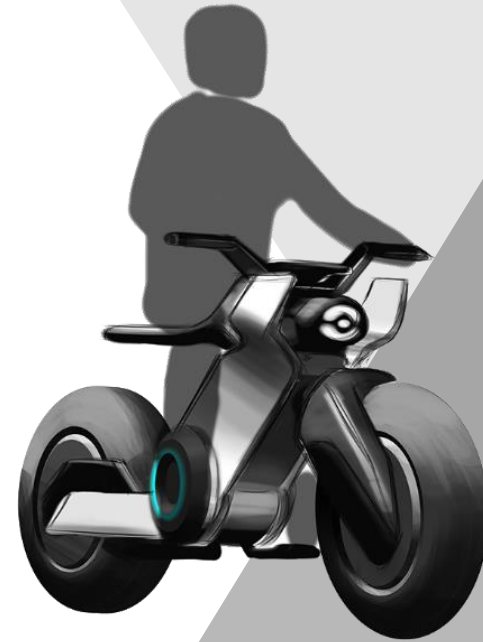

## BARE BONES

Lego like linkages help in transformation.  
Minimal surfaces

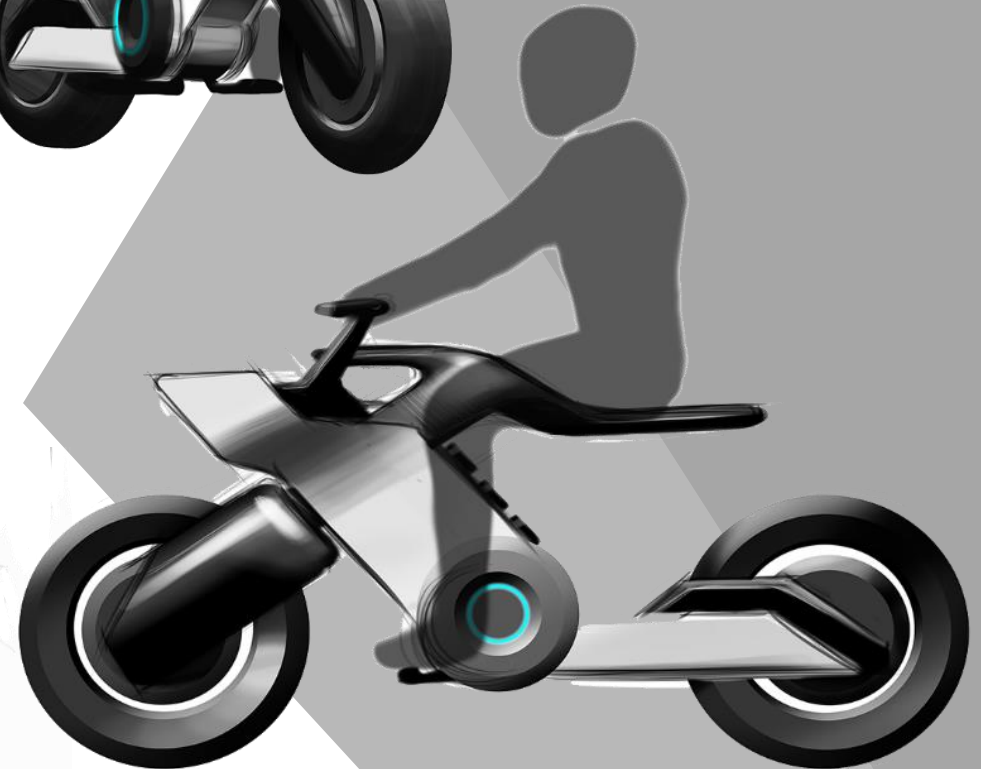

# Concept 3

- Transformation using a main central pivot
- The pivot used as an interface between the upper and lower volumes

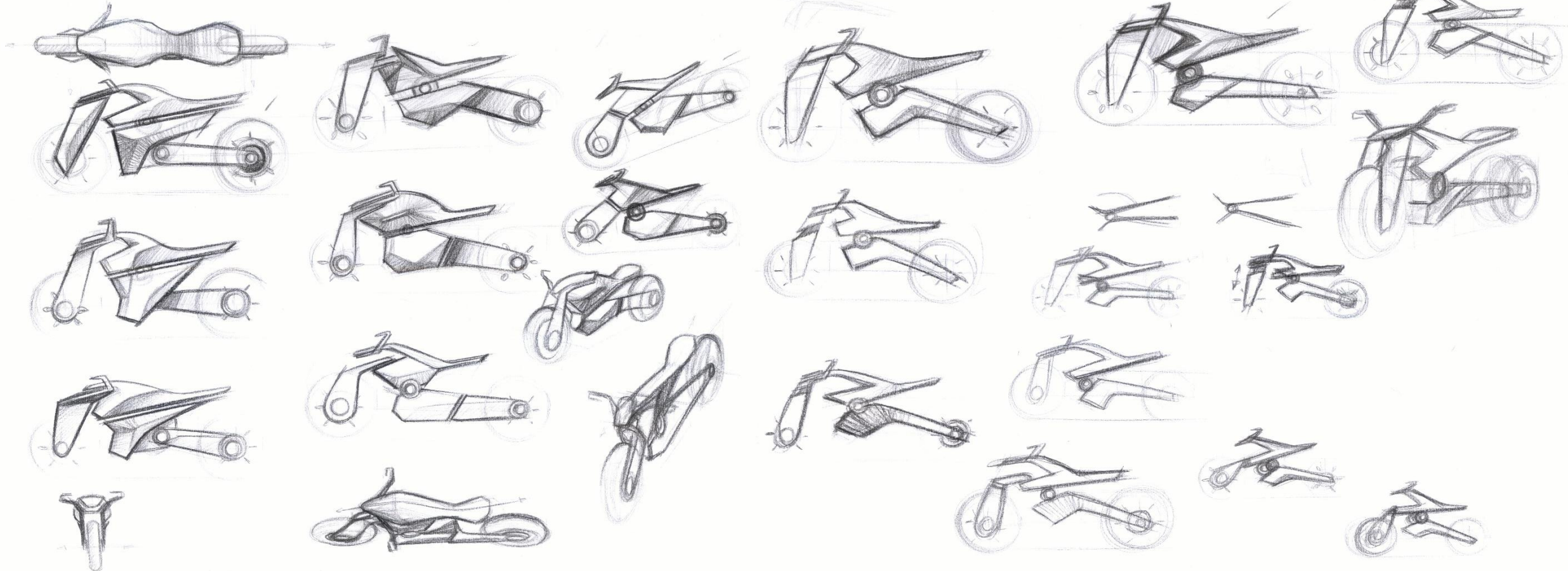
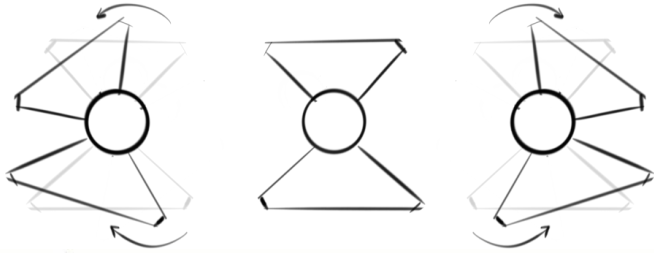

# Concept 3

Urban

Race

Off-road

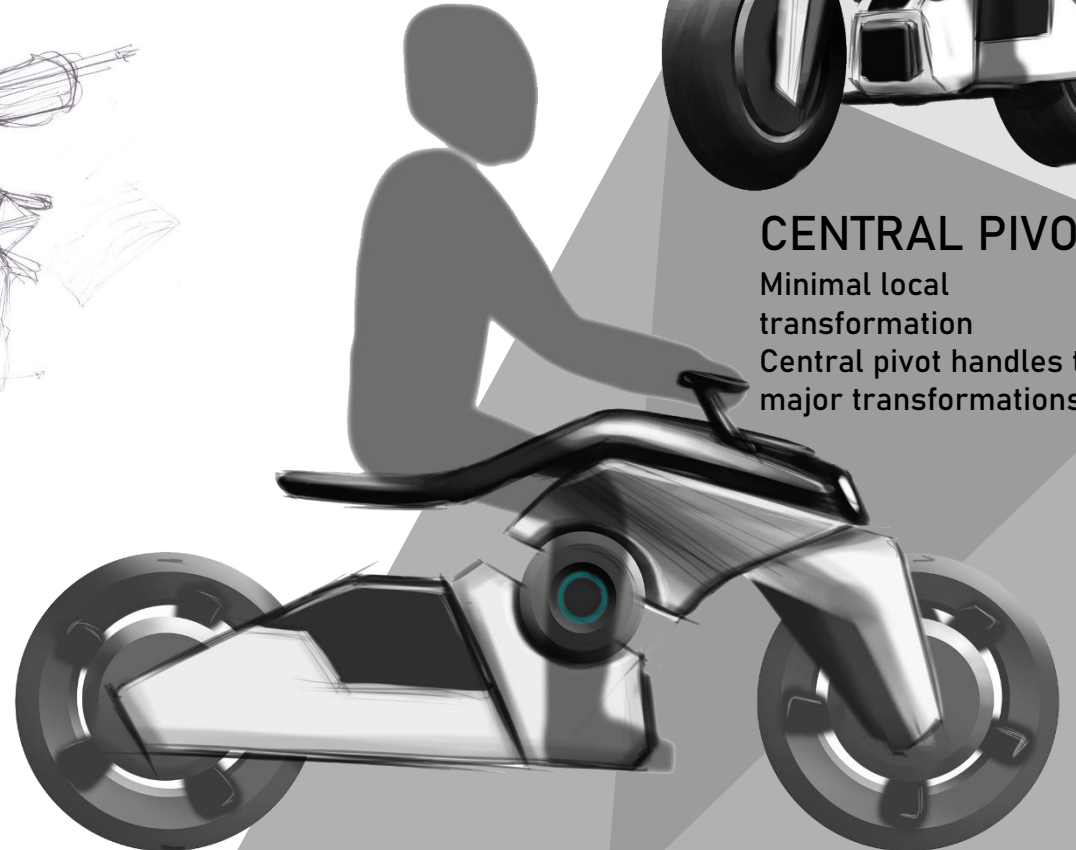
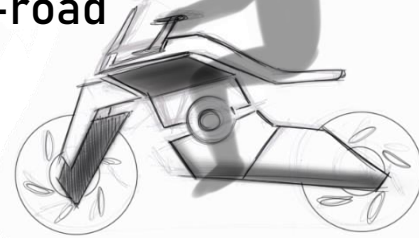
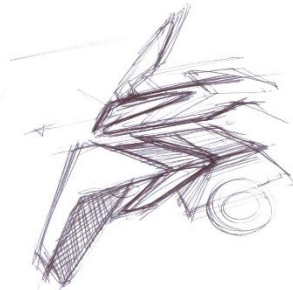
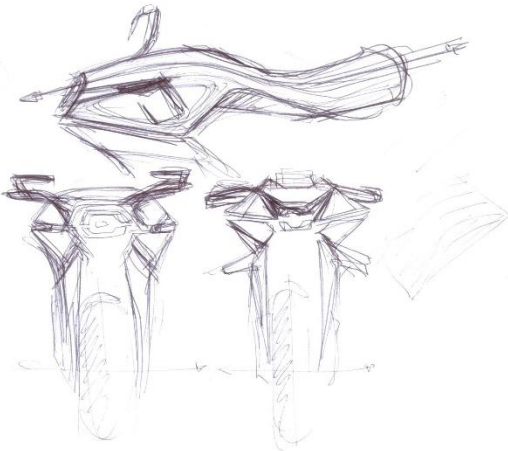
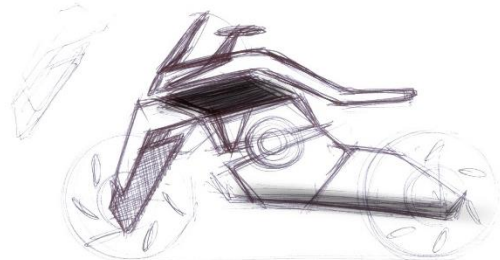
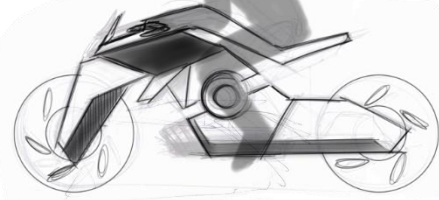
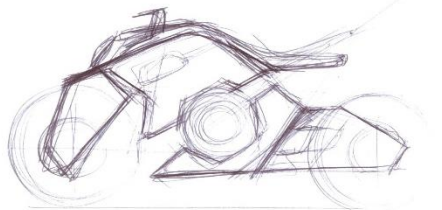
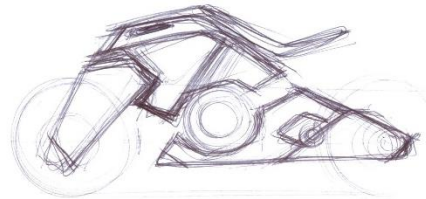
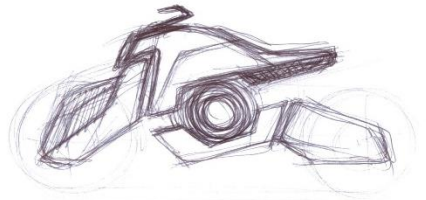
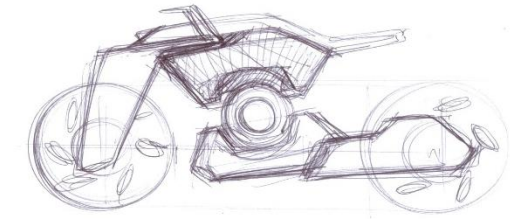

## CENTRAL PIVOT

Minimal local transformation  
Central pivot handles the major transformations

# Concept 4

- Combination of central pivot and active surfaces
- Major transformation handled by pivot, local transformations by surfaces

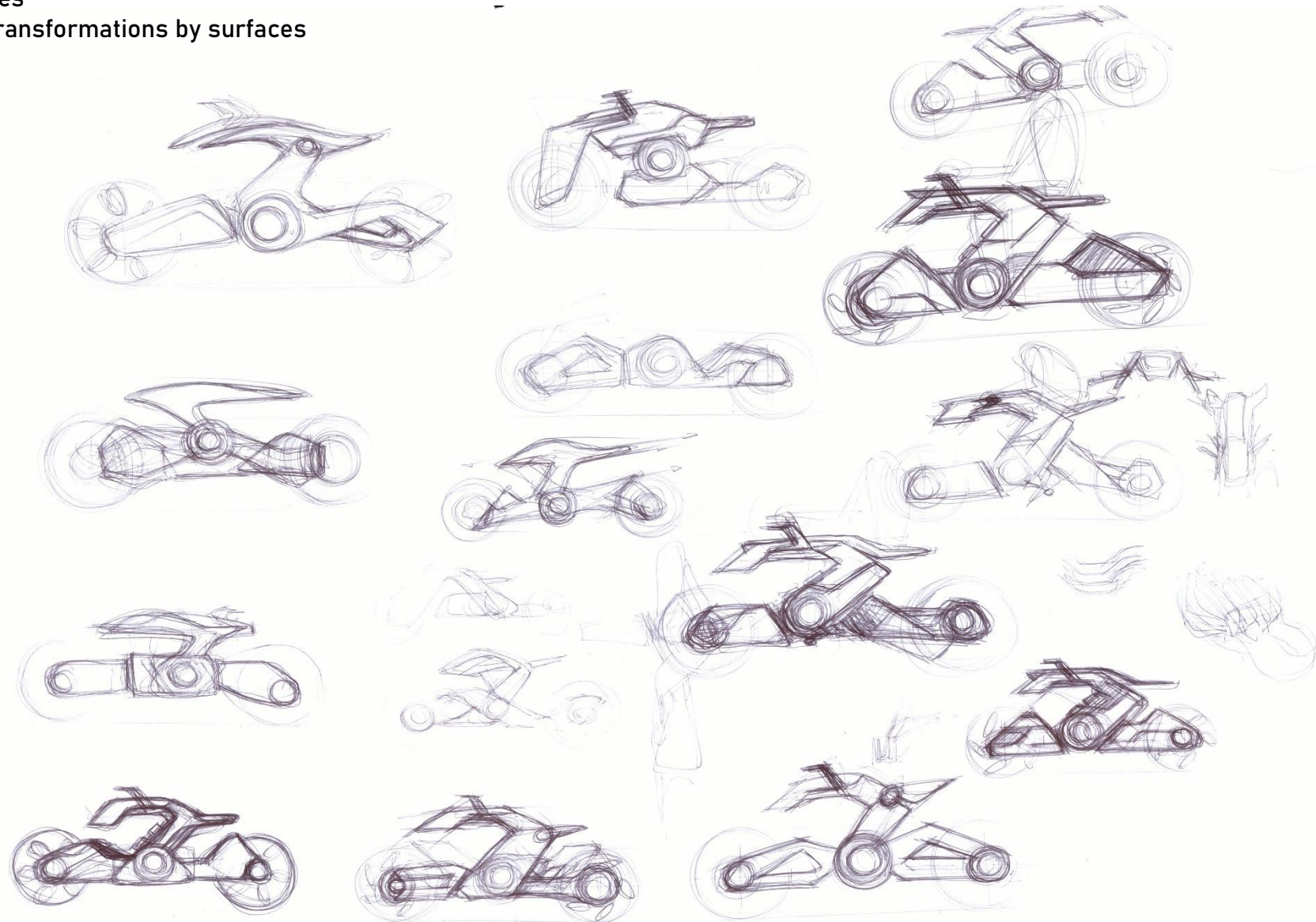
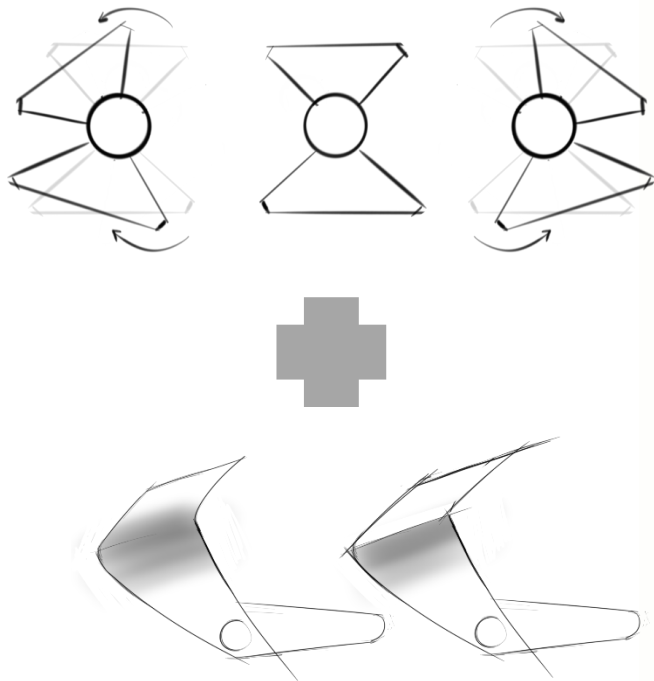

# Concept 4

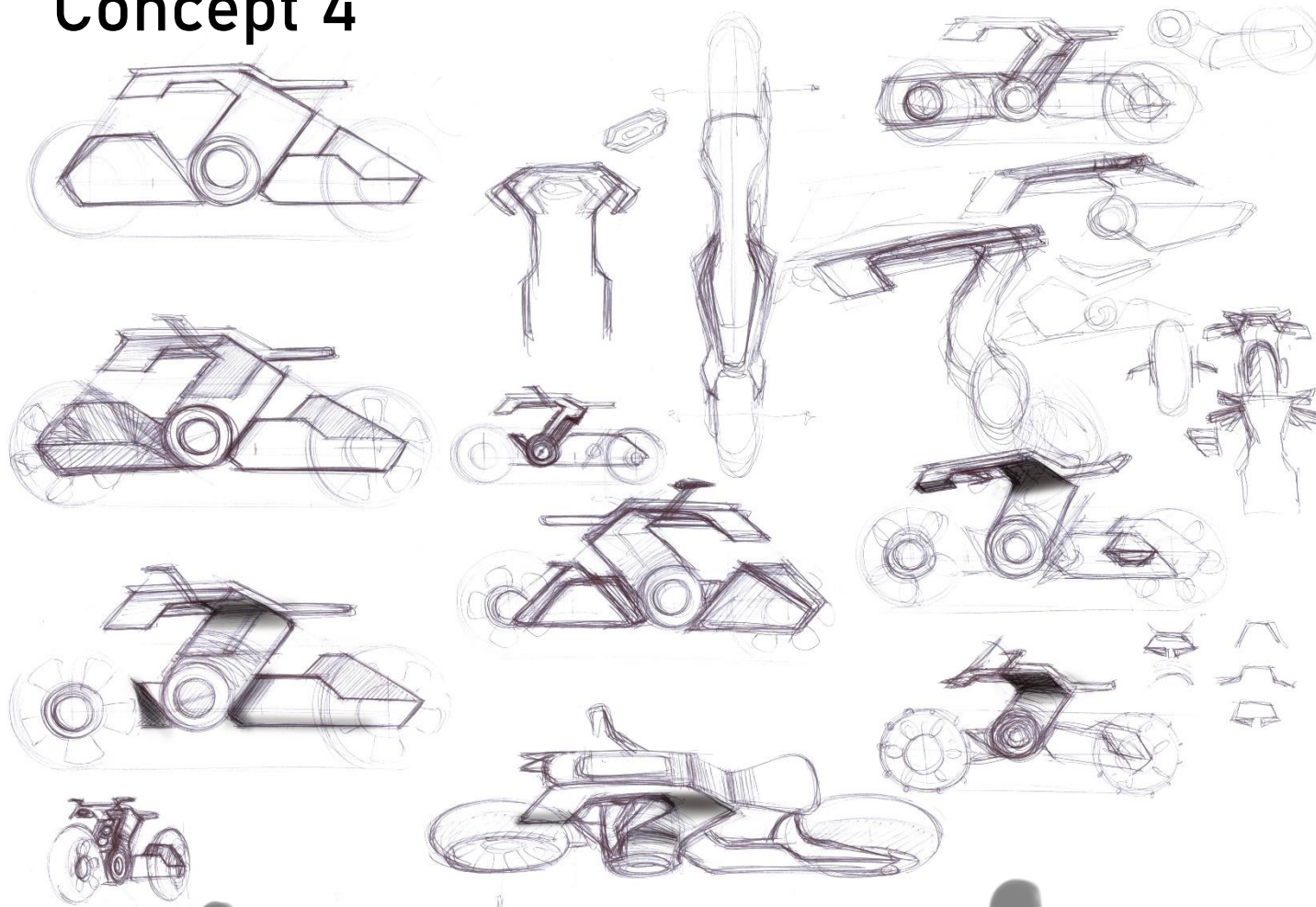

Standard



Race

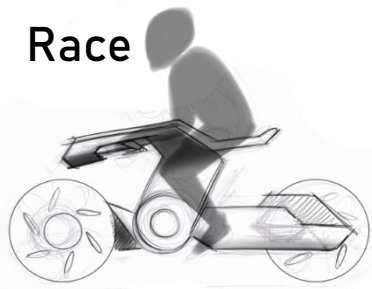

Off-road



## CENTRAL PIVOT + ACTIVE SKIN

Minimal local transformation  
Central pivot handles the major transformations

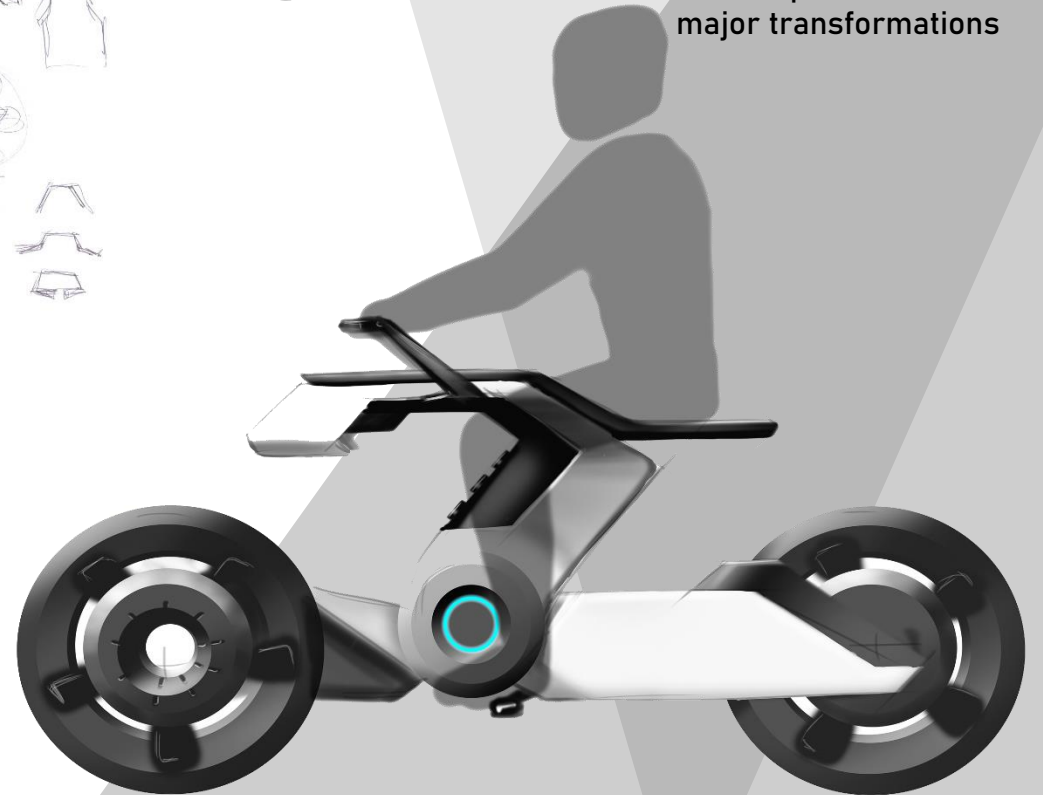

# Concept Evaluation

- An evaluation was conducted with 10 participants and a concept was selected to be developed further

Criteria	Concept 1	Concept 2	Concept 3	Concept 4
On a scale of 1-5, rate how much do you feel and anticipate that it looks like this design would transform	1.1	1.5	1.9	2.9
On a scale of 1-5, how futuristic do you think this design is	1.7	2.2	2.0	2.2
On a scale of 1-5, how much would you like to ride/enjoy riding this?	0.9	2.1	2.2	2.6
On a scale of 1-5, how satisfied are you with the transformation?	1.4	1.9	2.4	3.0

# Design development

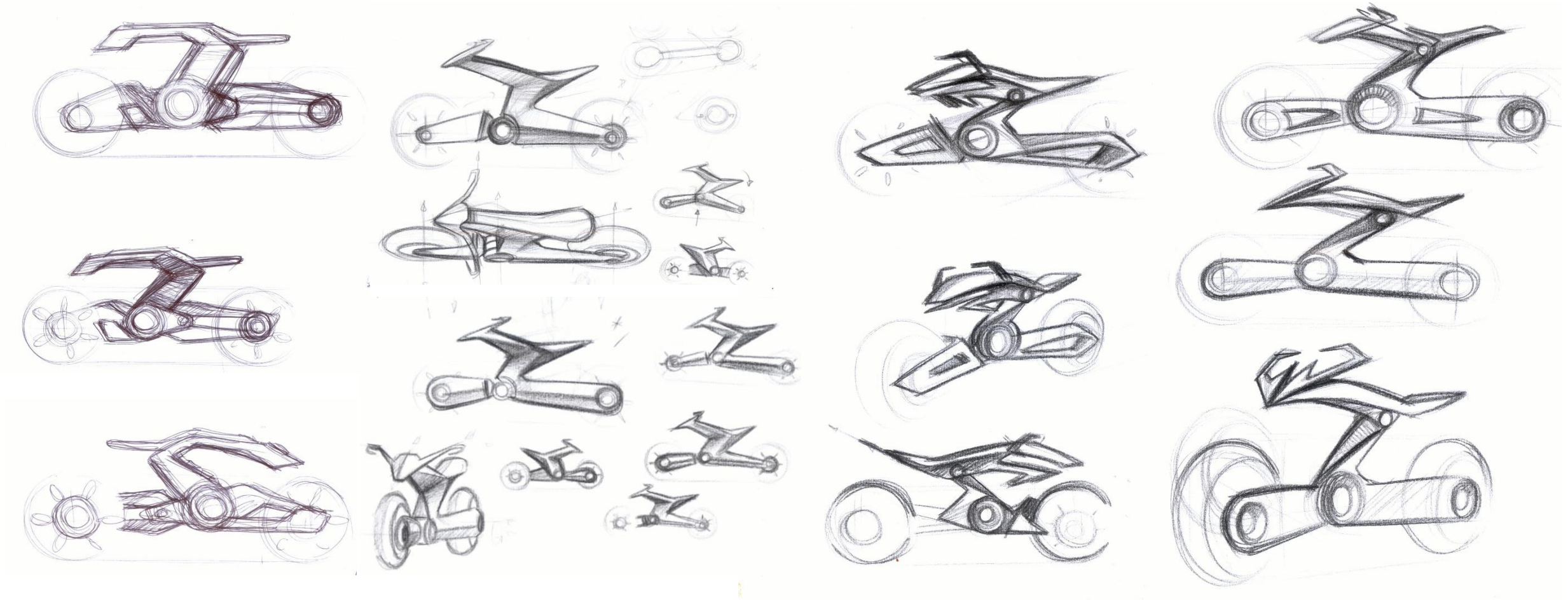

# Design development

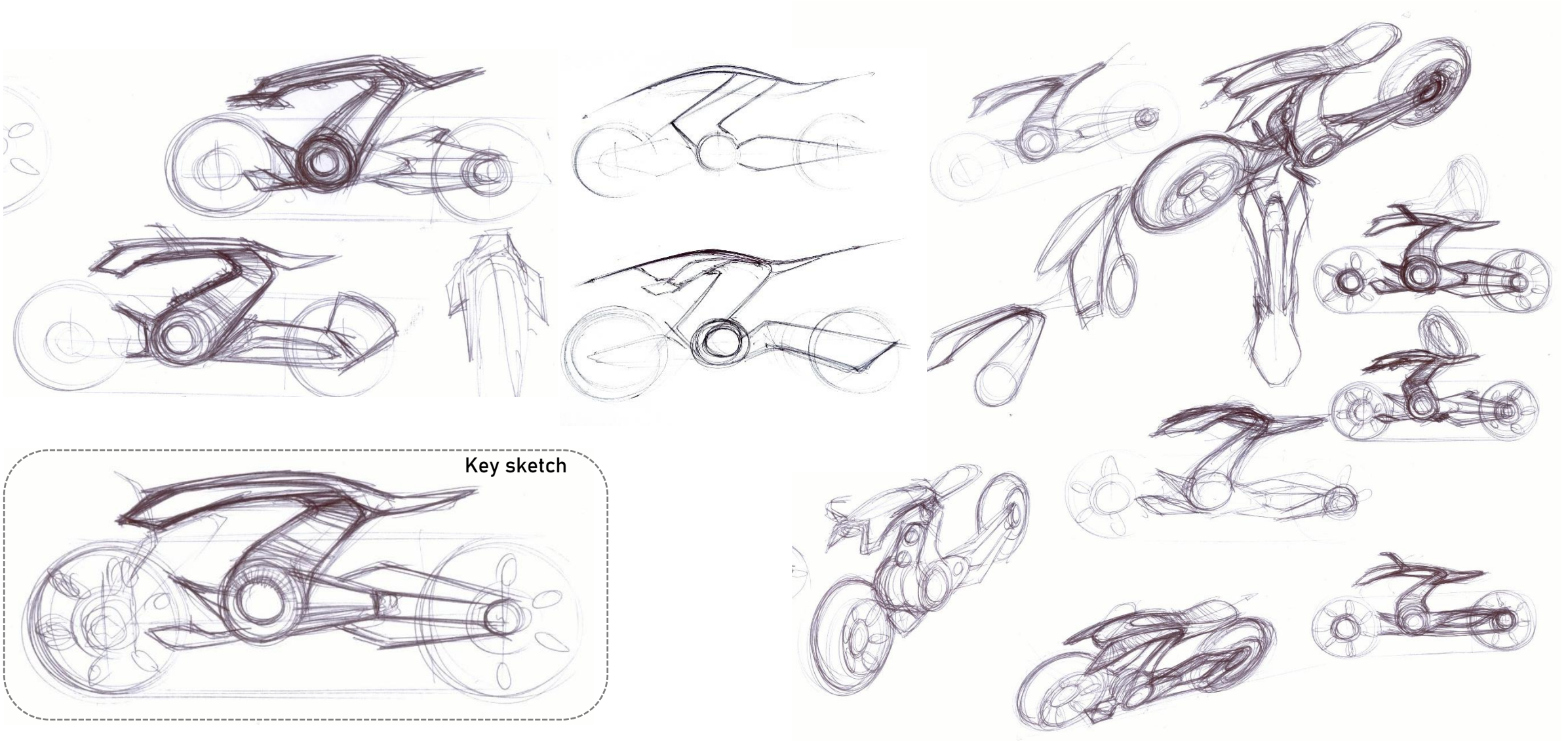

# Design development

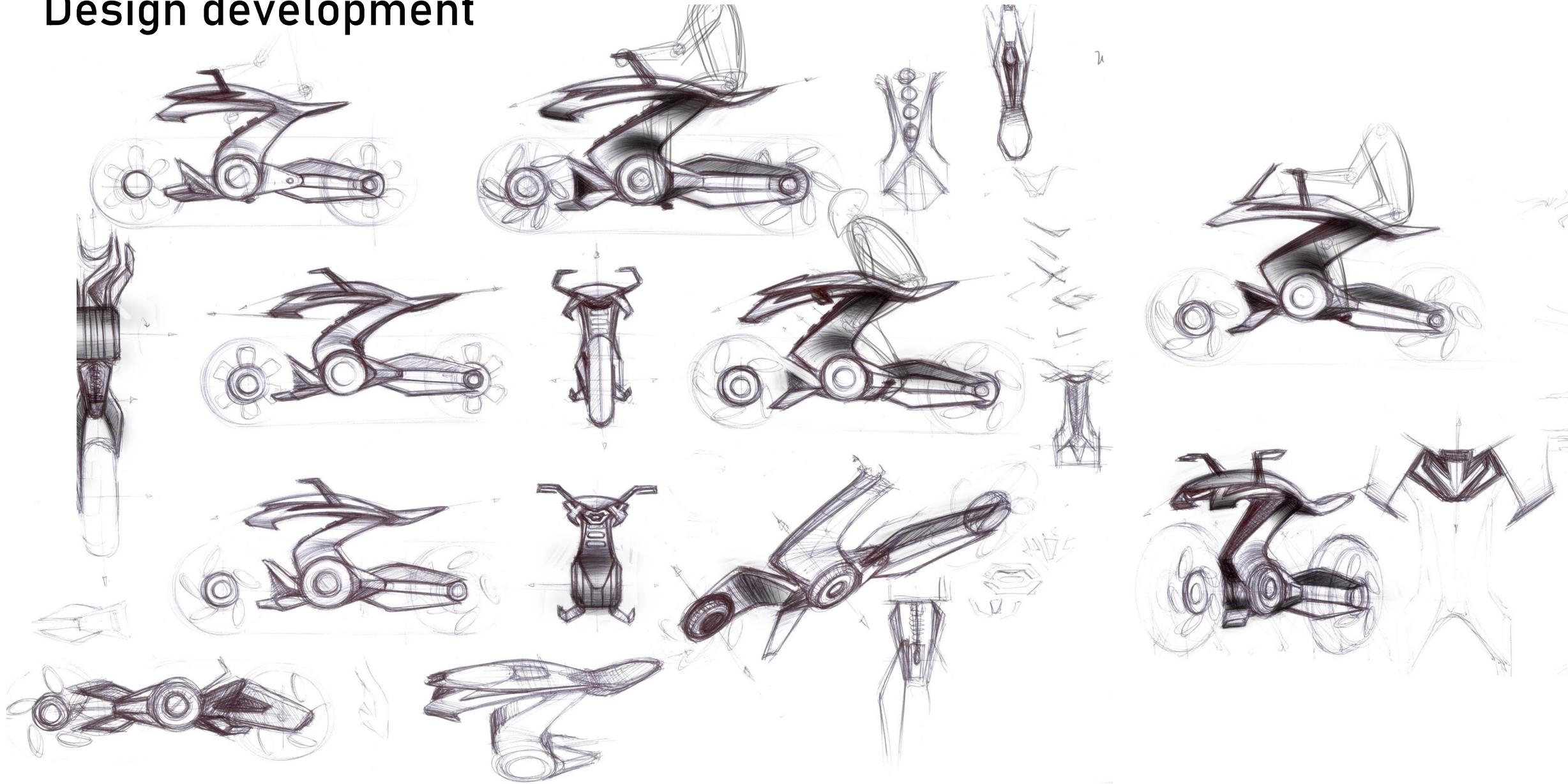

## Urban

Relaxed seating with upright body posture

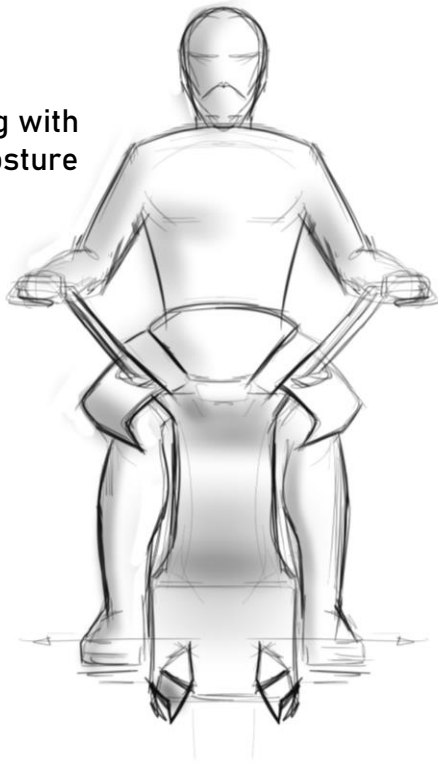

## Race

Lean forward seating - more aggressive

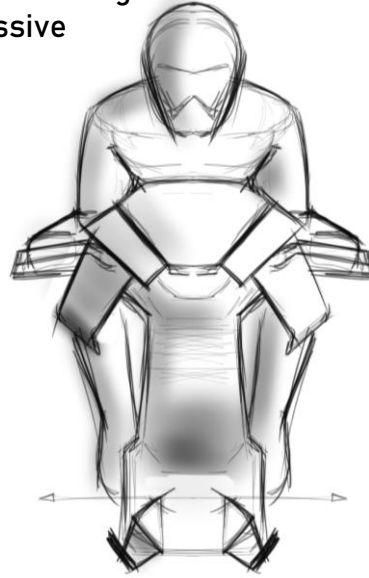

## Off-road

Upright posture with higher handle height

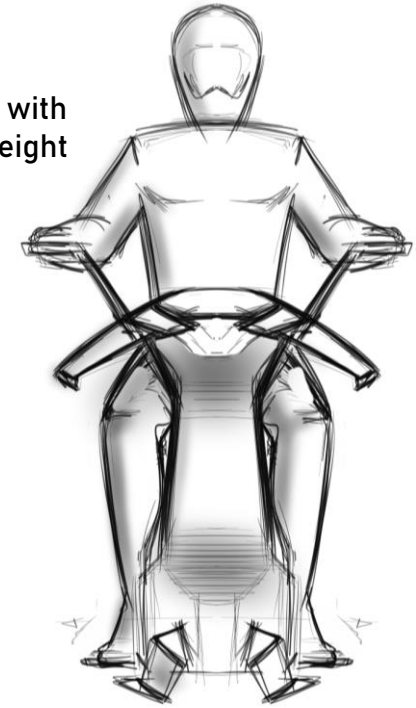

Handles at mid level to keep arms relaxed and back straight

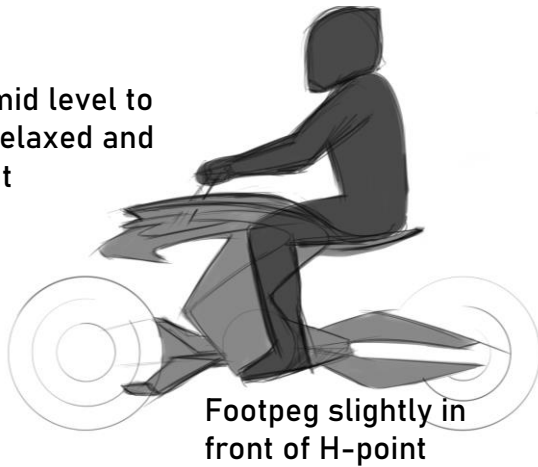

Handles lower and keeps arms tighter to body to give better control while turning

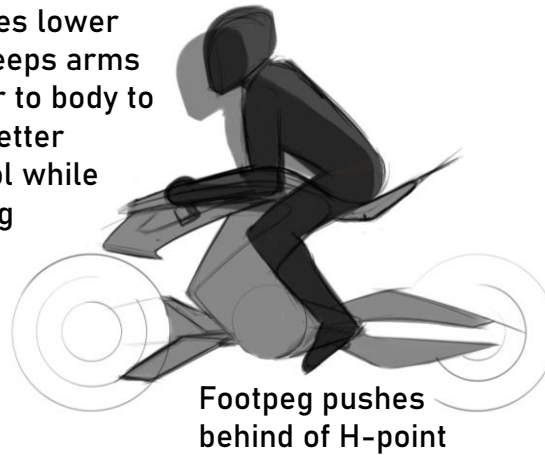

Higher handle also helps rider manage ride while he rides standing up in rough terrain

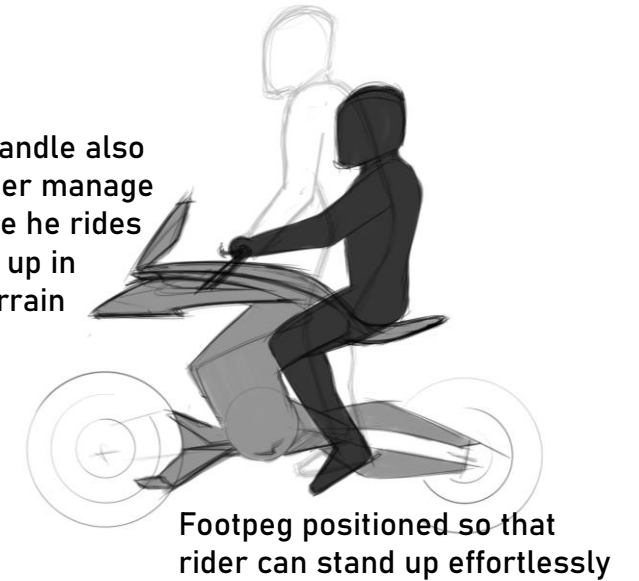

## Urban

Upper fin is folded

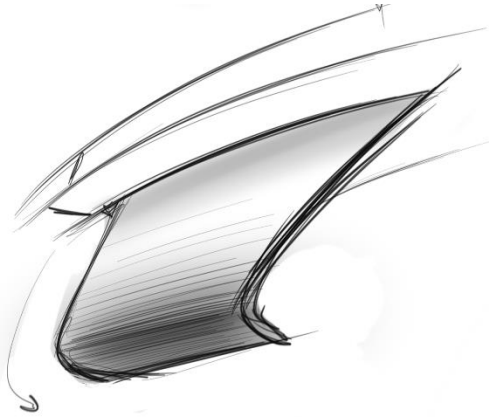
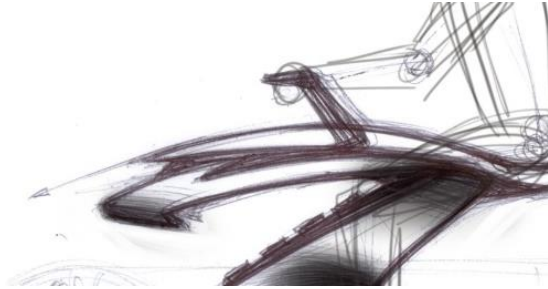

## Race

Fins deploy

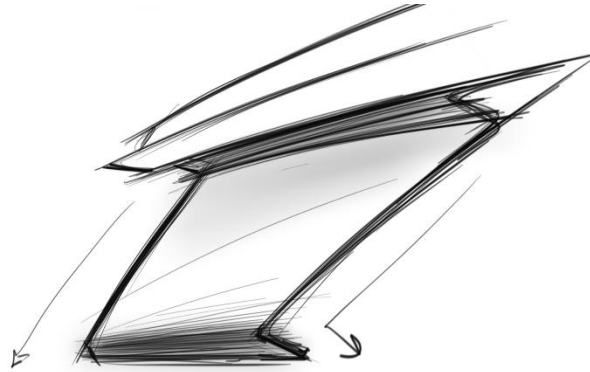

## Off-road

Fin raises up to give feeling of increased volume

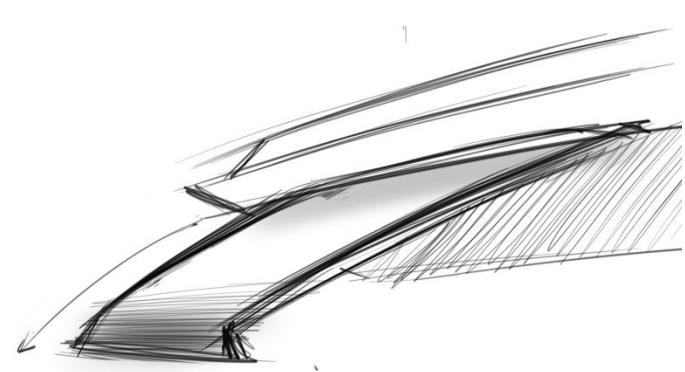
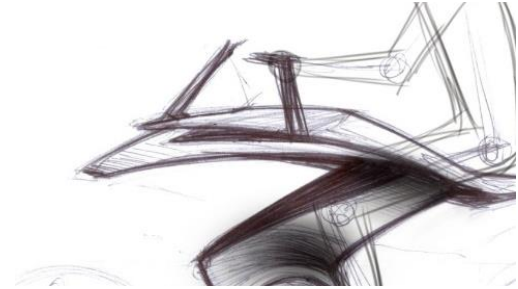

## Urban

Lower fin is folded

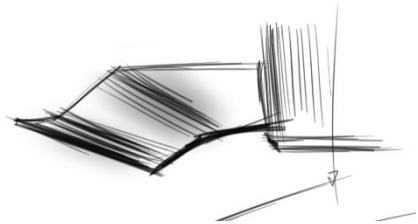
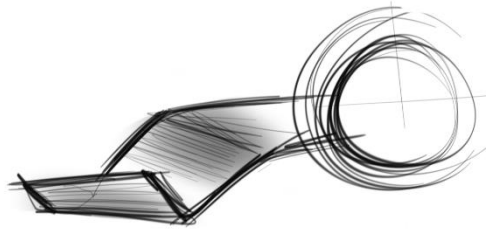
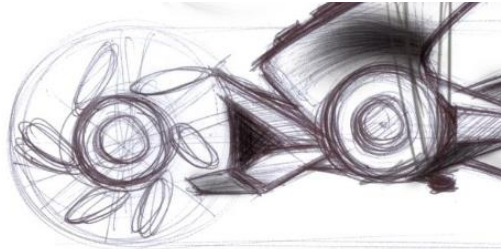

## Race

Fins deployed - aggression

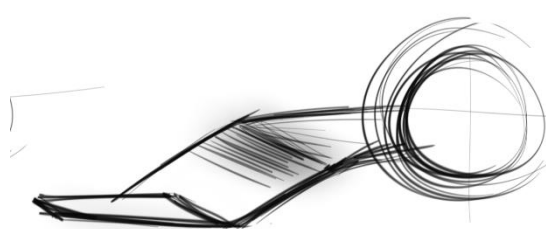
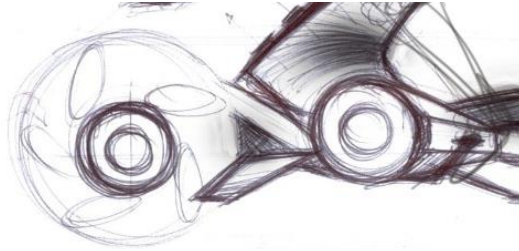

## Off-road

Fins double up as mudguard

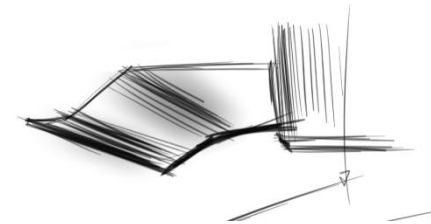
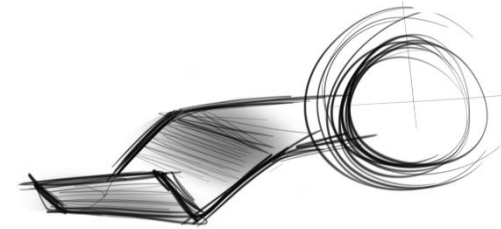
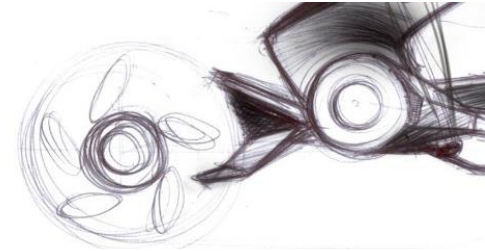

## Urban

Softer and compact tank volume

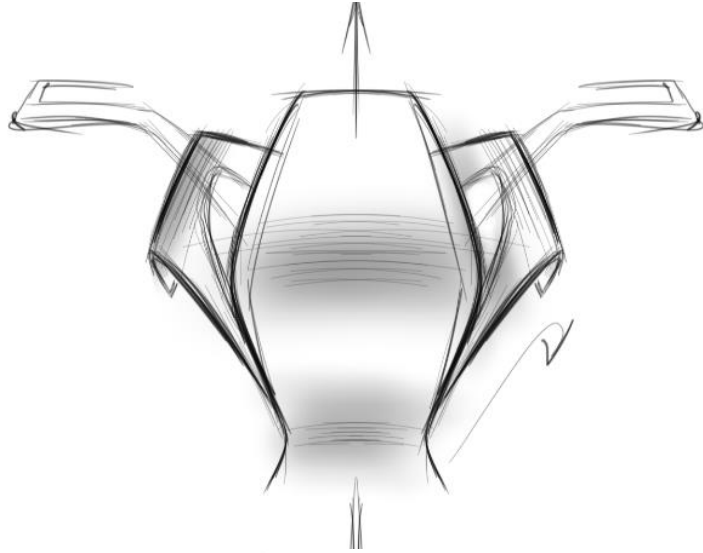

Seating in relaxed posture

## Race

Volume sharper and edgier

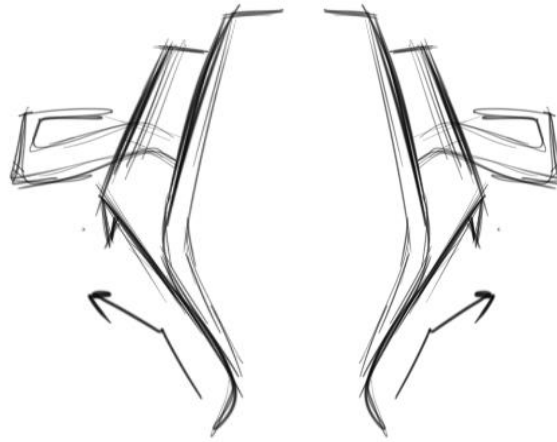

Seat folds up shifting the rider to a lean forward posture

## Off-road

Tank along with raised fins give a feeling of increased volume

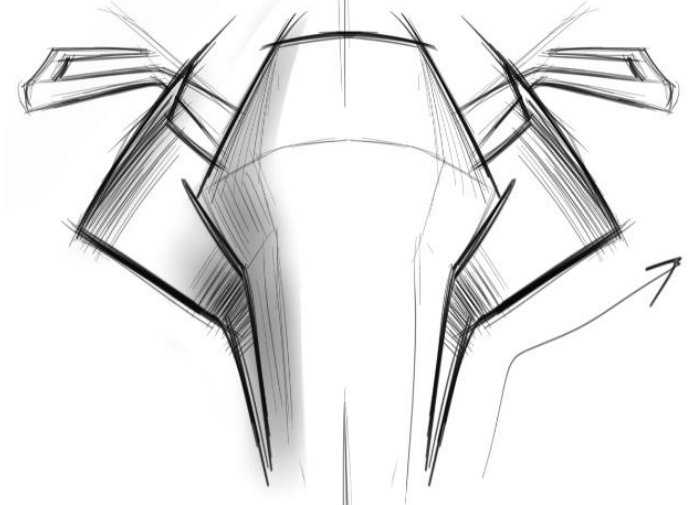

Seat lowers with tank rising up

Final concept

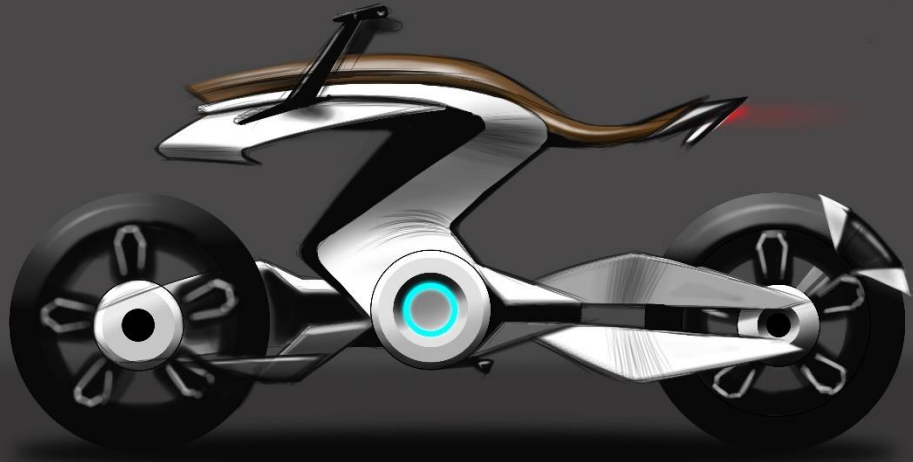

Urban

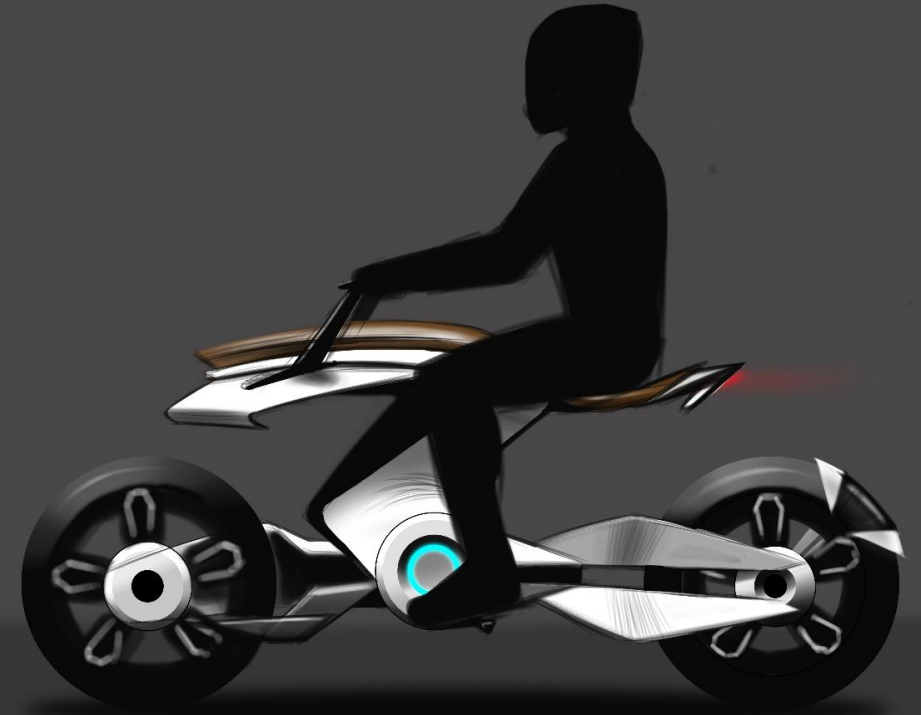
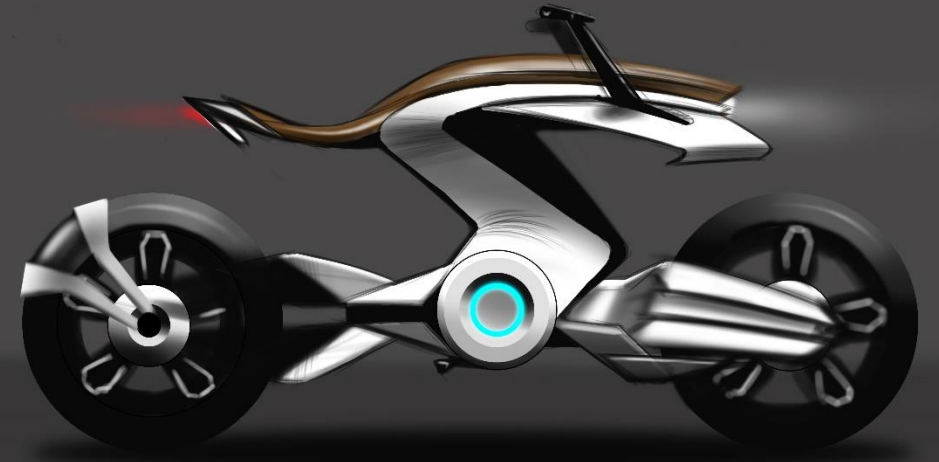

Final concept

Race

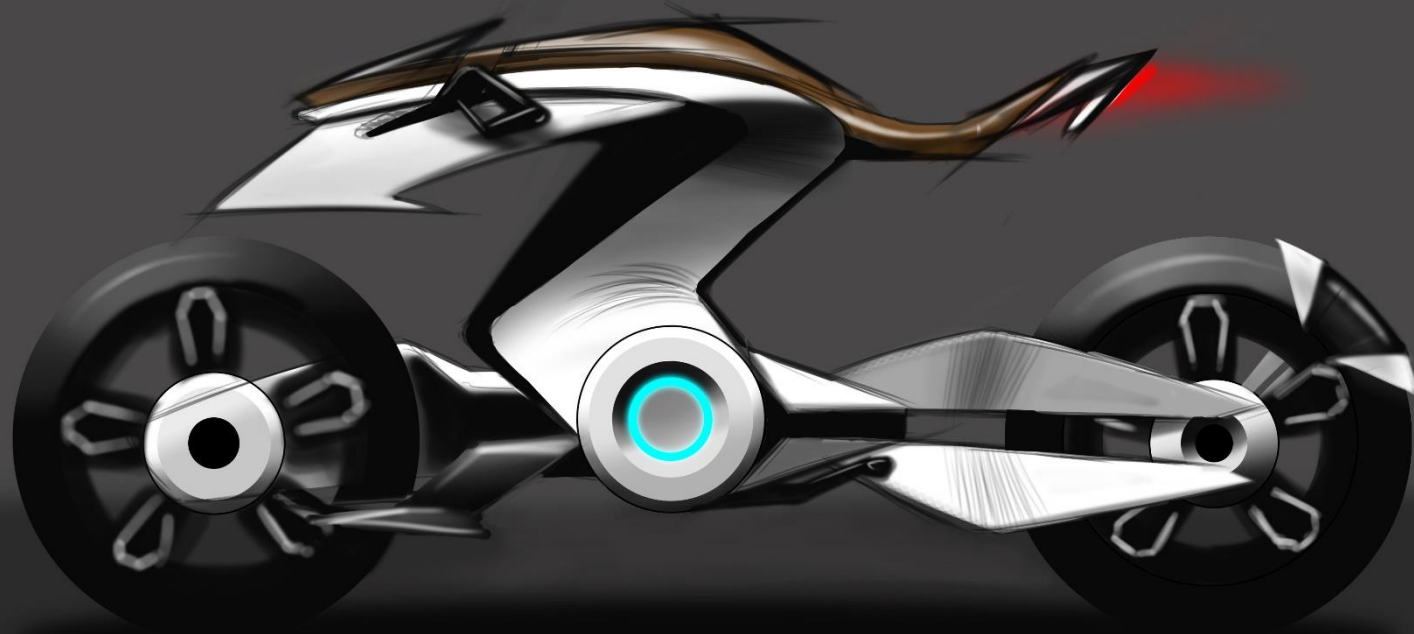

Final concept

Off-road

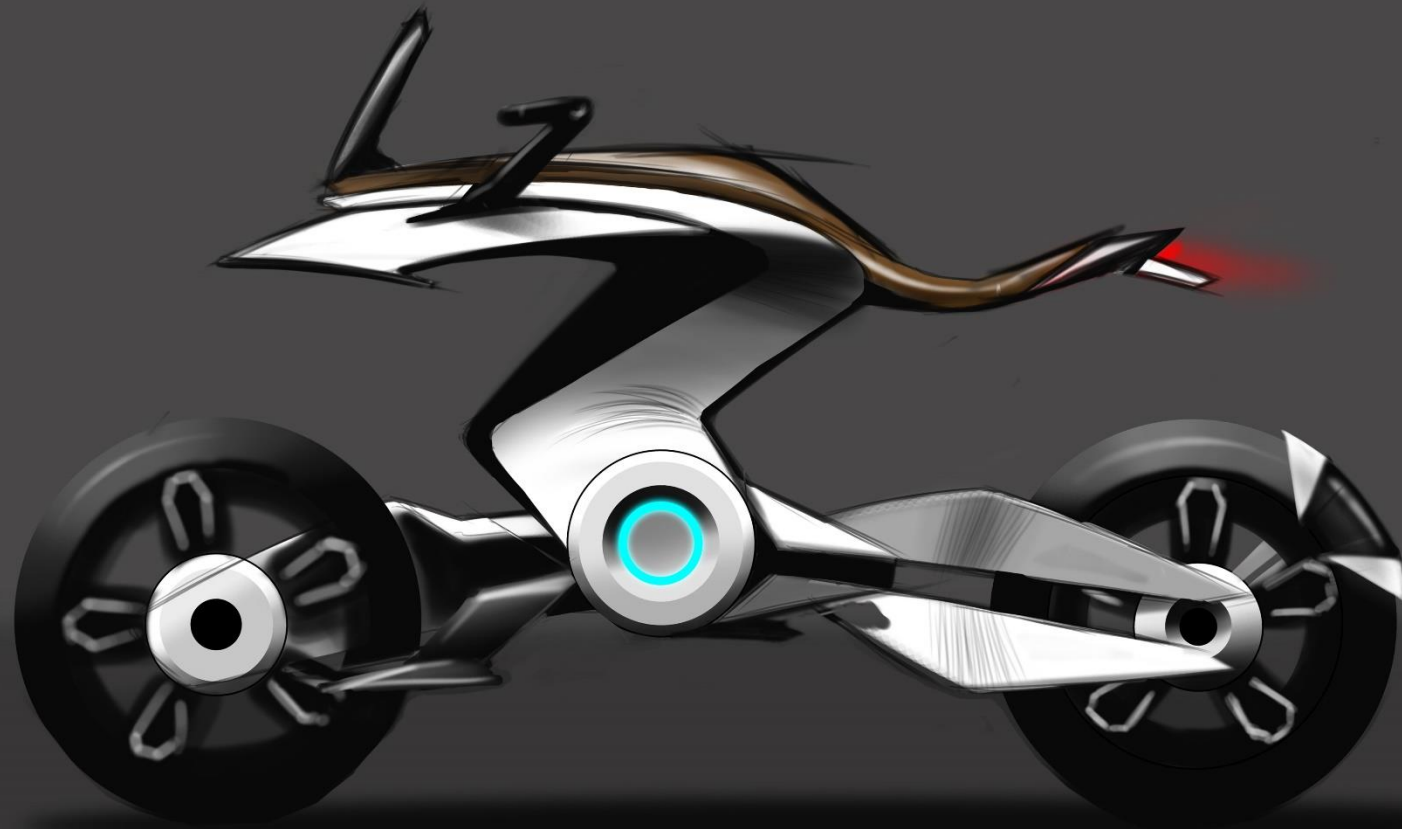

# Final concept

Customizability

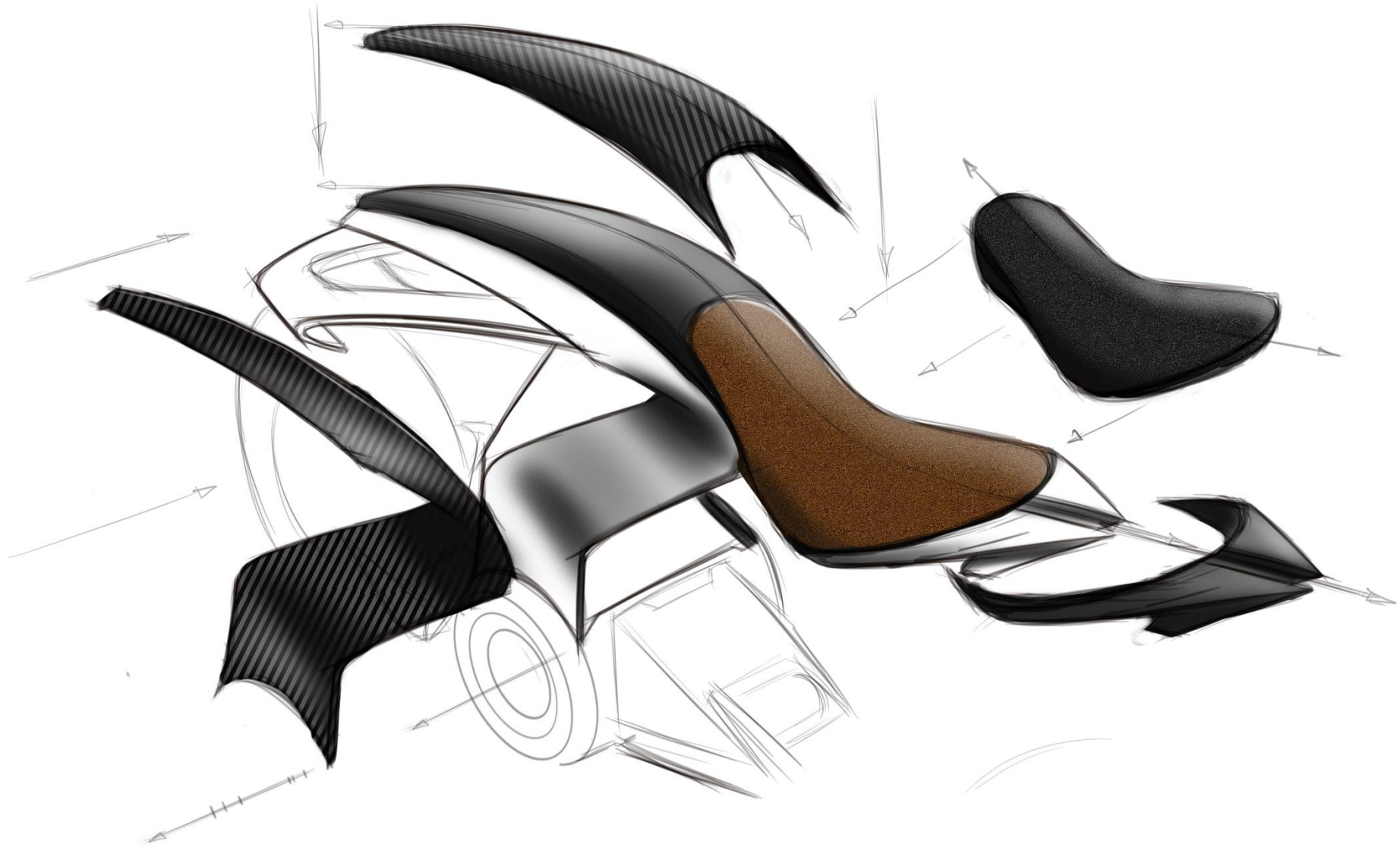

# Final concept

## Screen experience - Urban



Lighter theme with  
subtle graphics



14/6/35  
08:25am  
28°C

14hrs | 500km 90%  
urban

40km/h

116

# Final concept

## Screen experience - Race



Dark theme, sporty graphics



# Final concept

## Screen experience - Offroad

Dark theme retained,  
but colour scheme  
changes

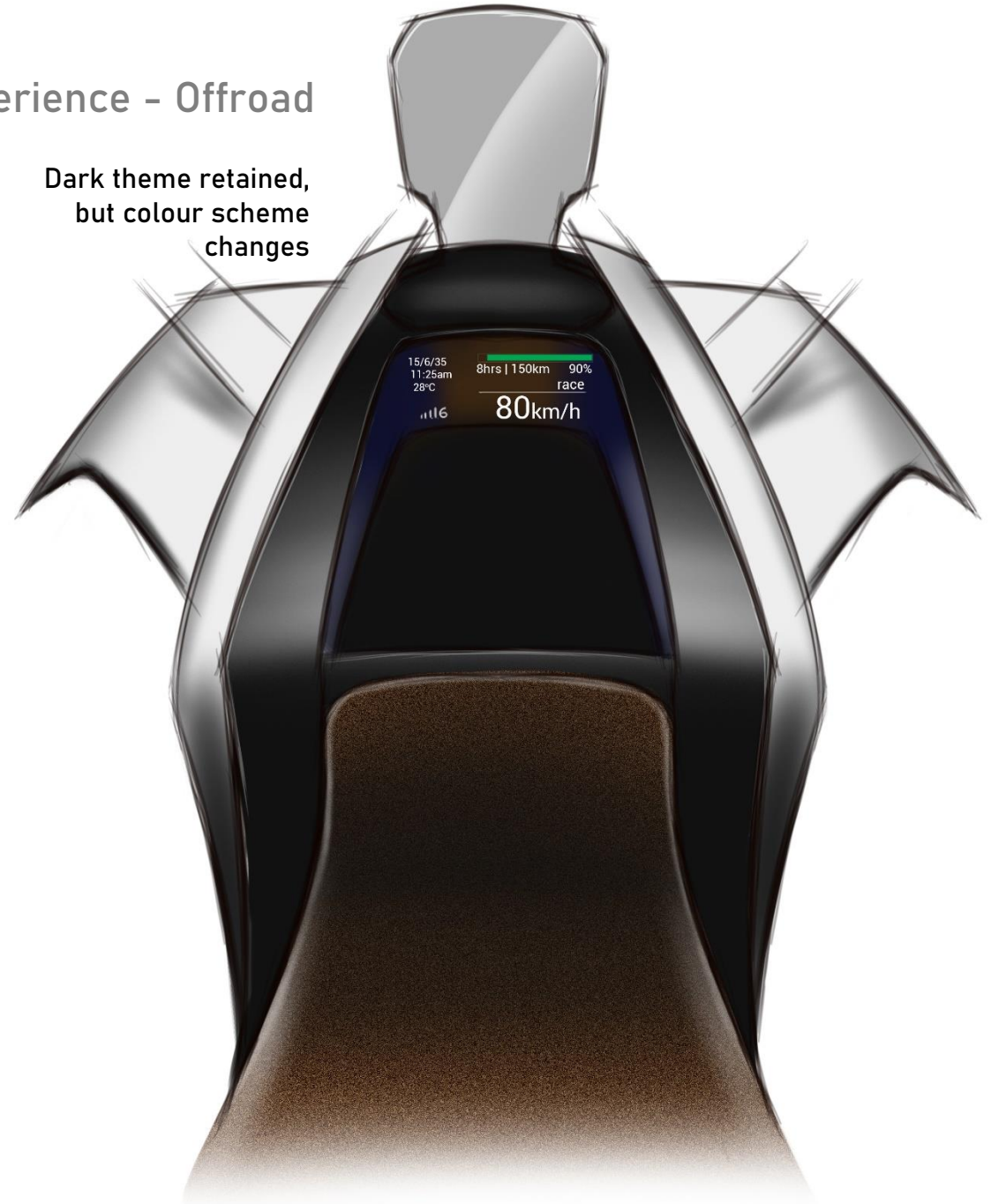

# Final concept

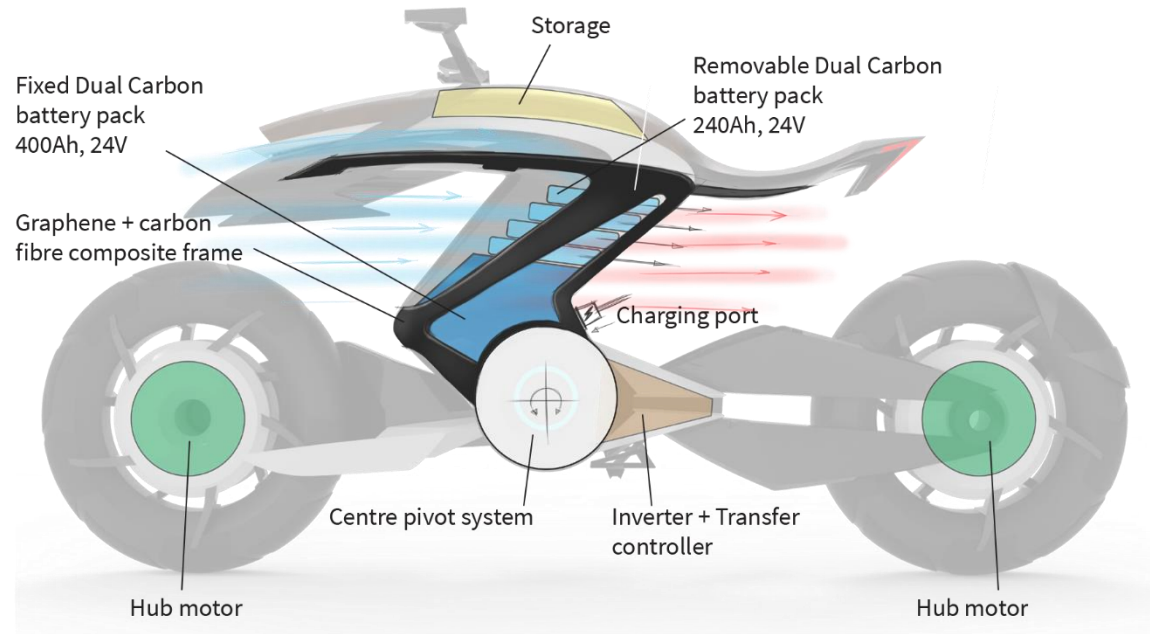

# Layout

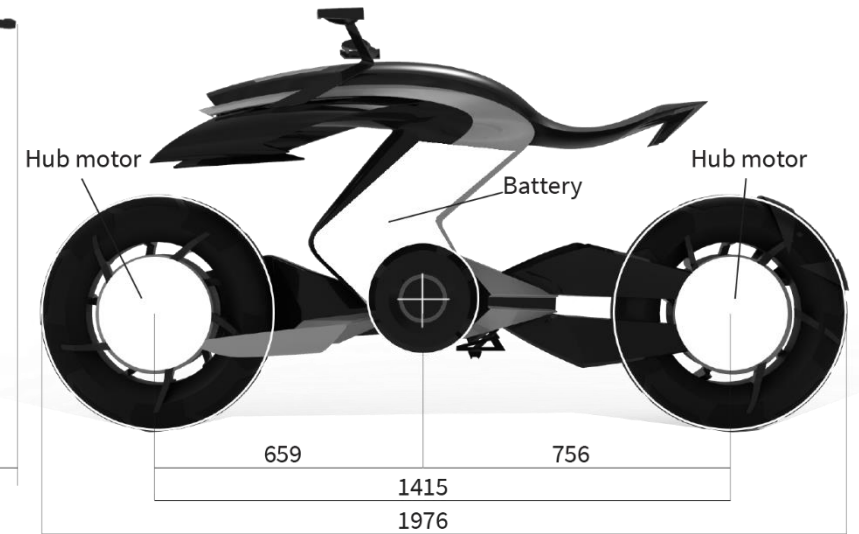
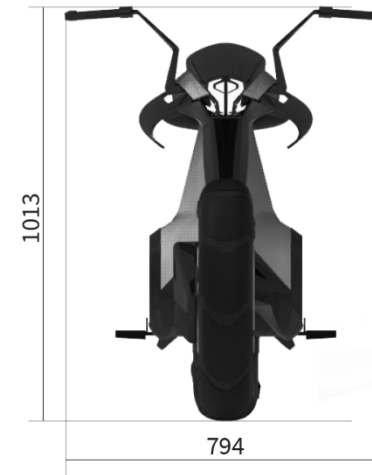

- 
- Research
  - Scenario
  - Design Brief
  - Concepts
  - **Final Design**

# Final design

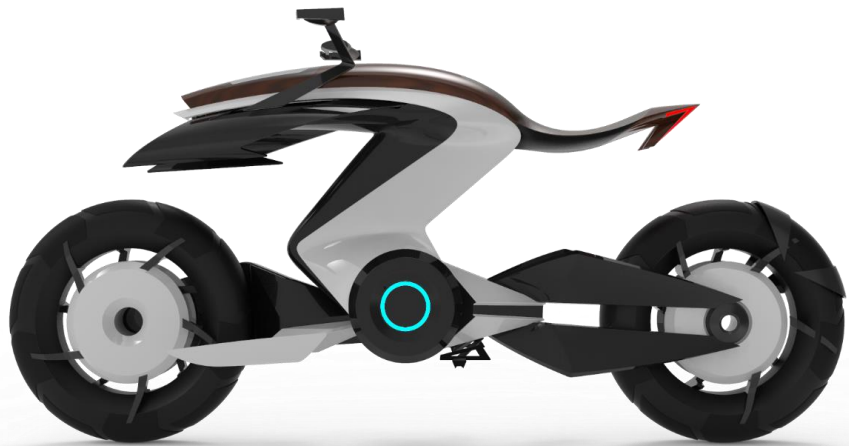

## Urban

Handle bar height for relaxed hand position

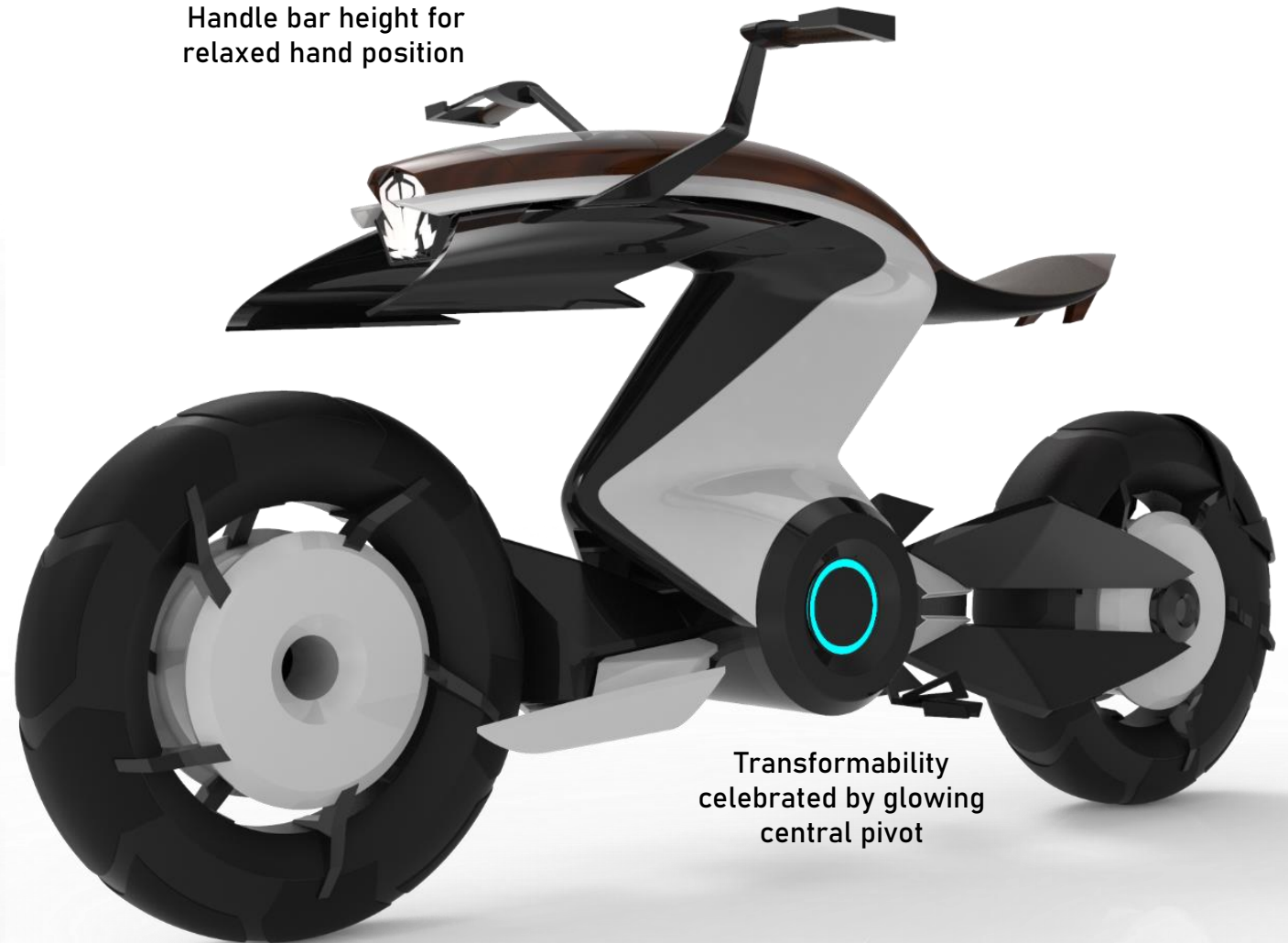

Transformability  
celebrated by glowing  
central pivot

# Final design



Swingarm extends to  
increase stability at  
hi-speeds

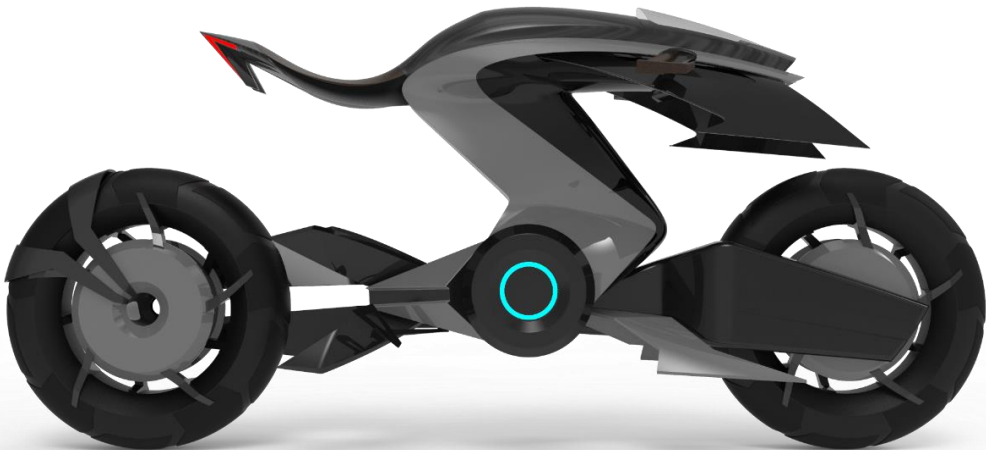

# Race

Low handles and  
aggressive posture

Fins straightened out

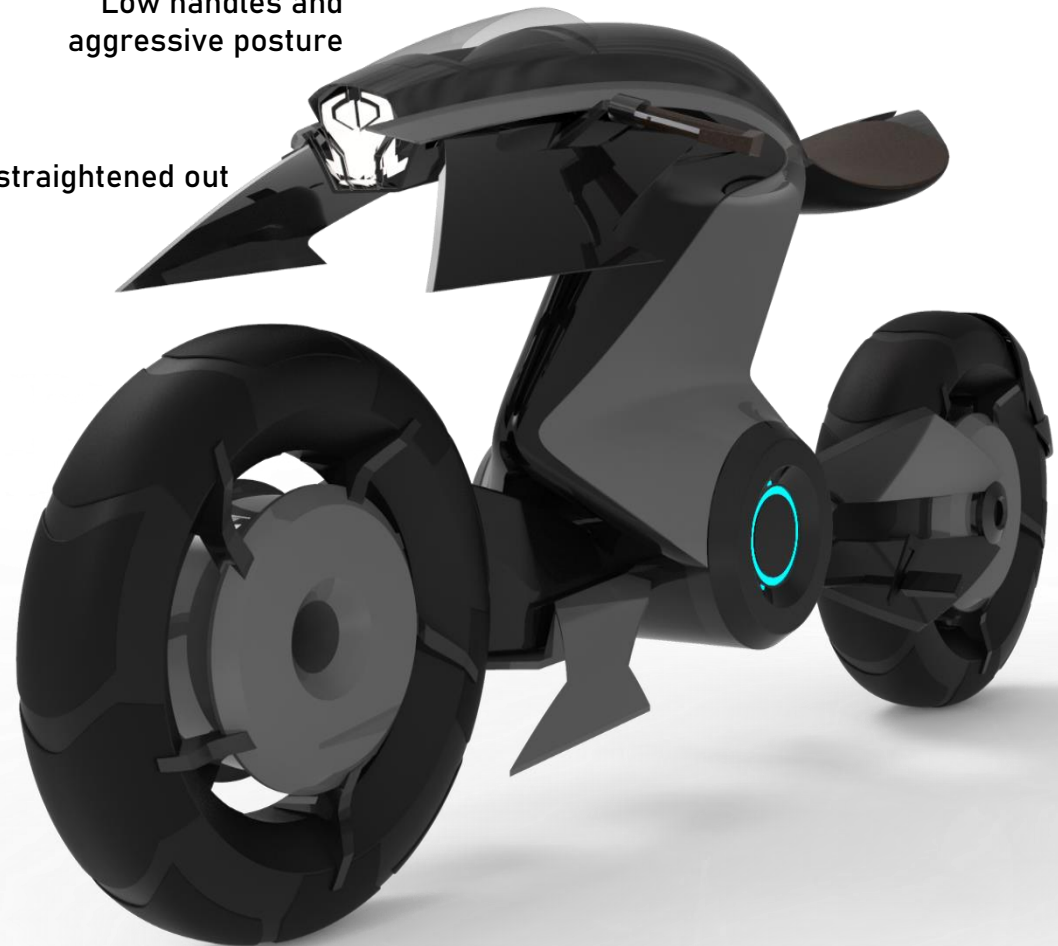

# Final design

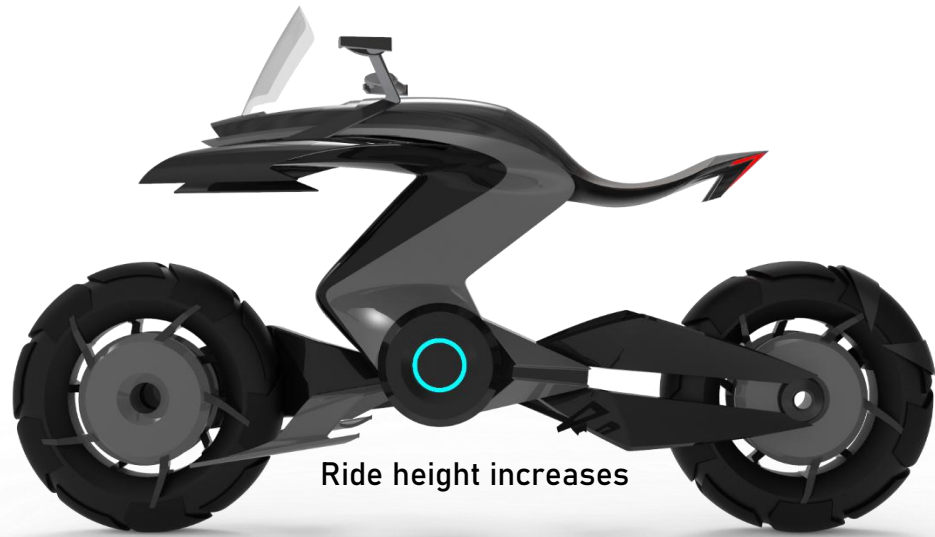

Ride height increases



# Adventure

Windscreen pops up



Tyre sections pop up  
changing tread pattern

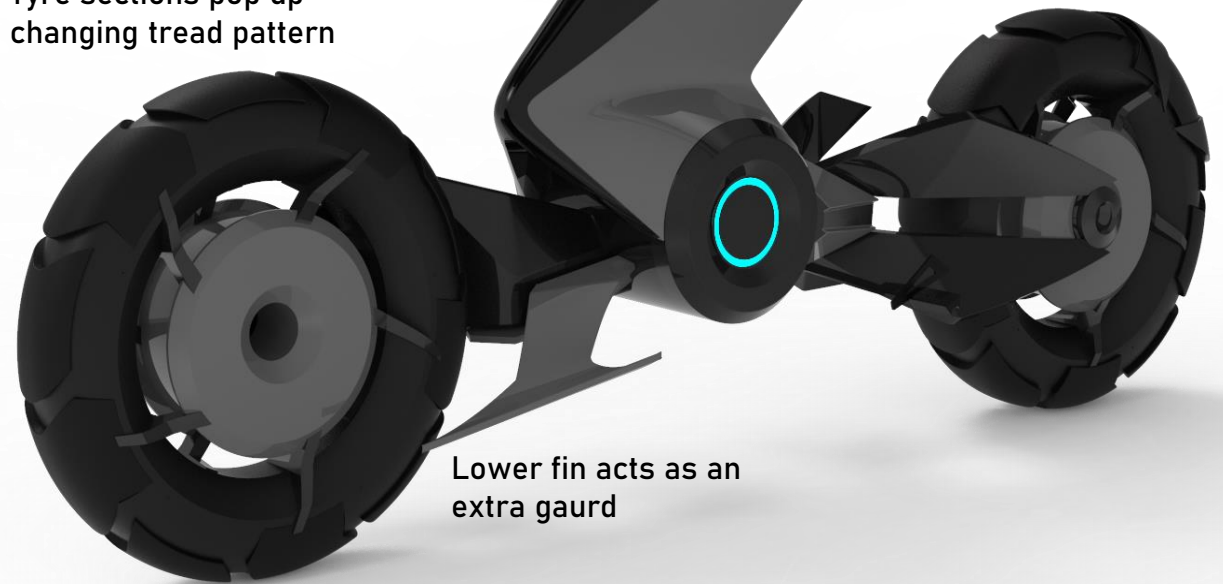

Lower fin acts as an  
extra gaurd

# Final design

Urban



## Ride ergonomics

Race



Off-road



# Final design

## Transformation

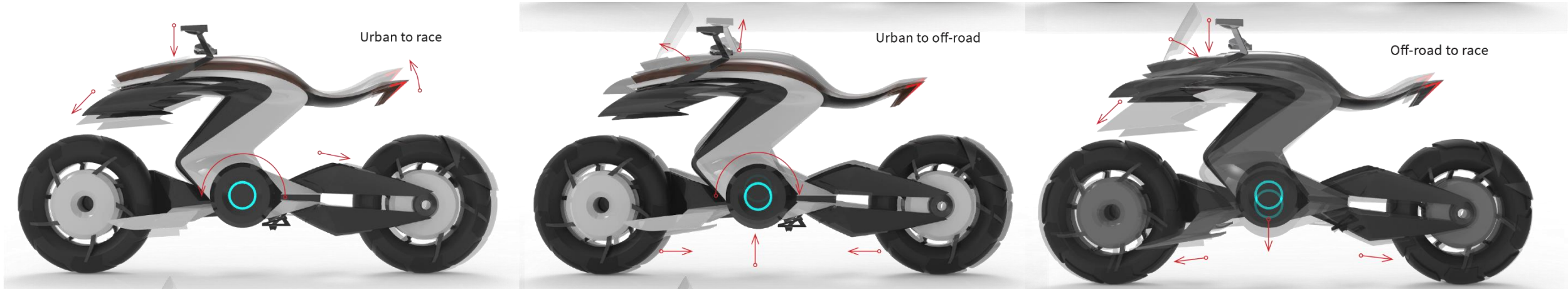

# Final design

Urban



## Transformation

Race



Off-road

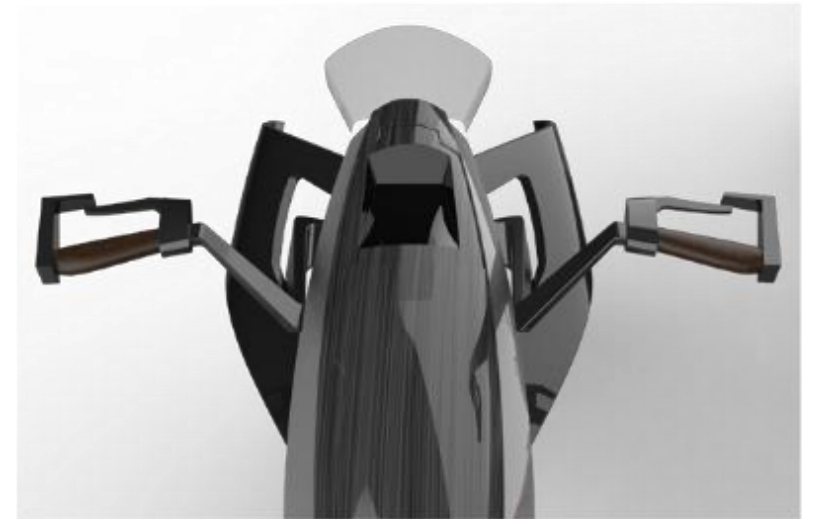

# Final design

## Transformation

Urban

Race

Off-road

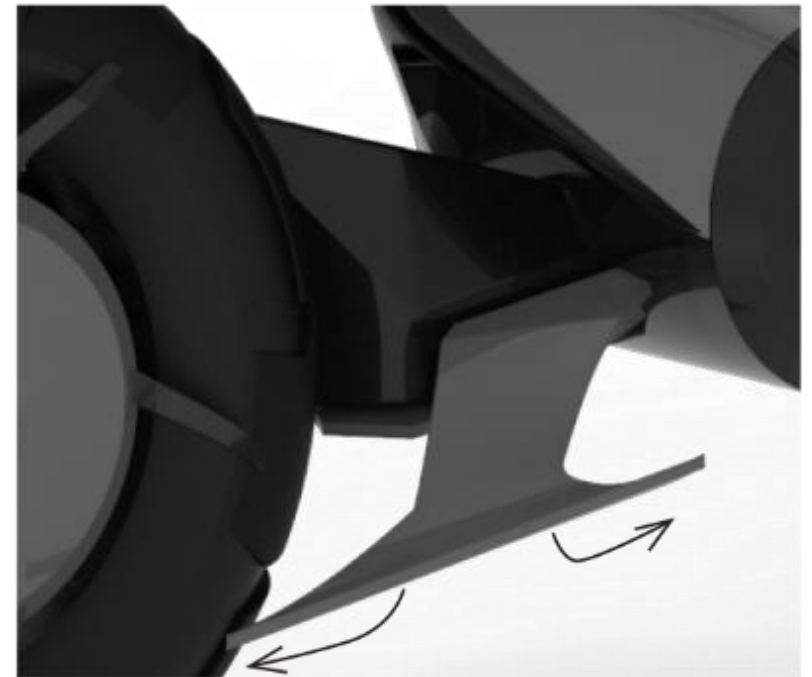
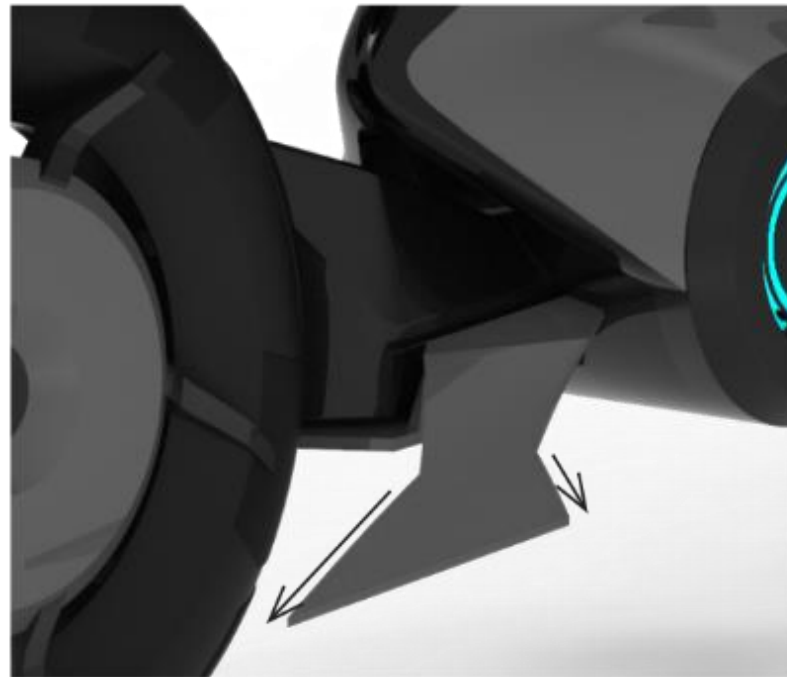
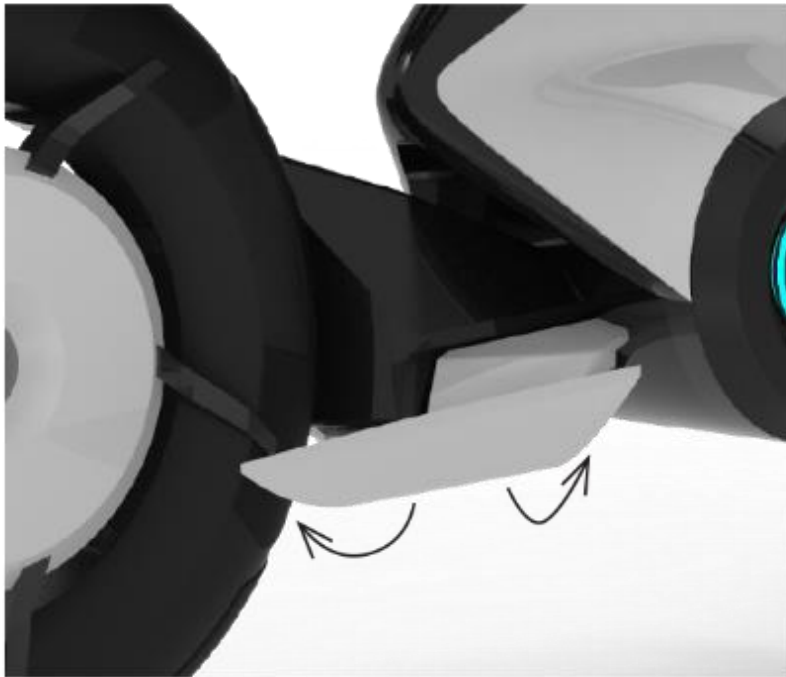

# Final design

Urban



Transformation

Race



Off-road



# Final design

Urban

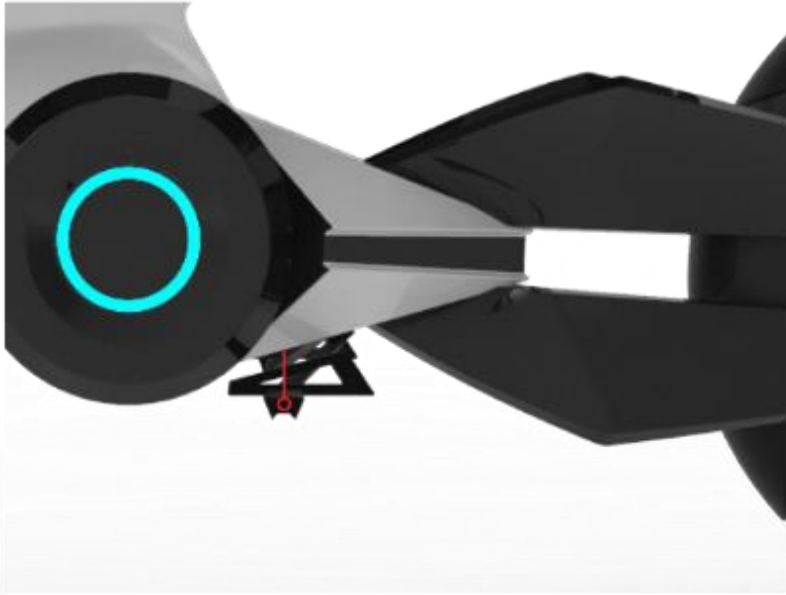

## Transformation

Race

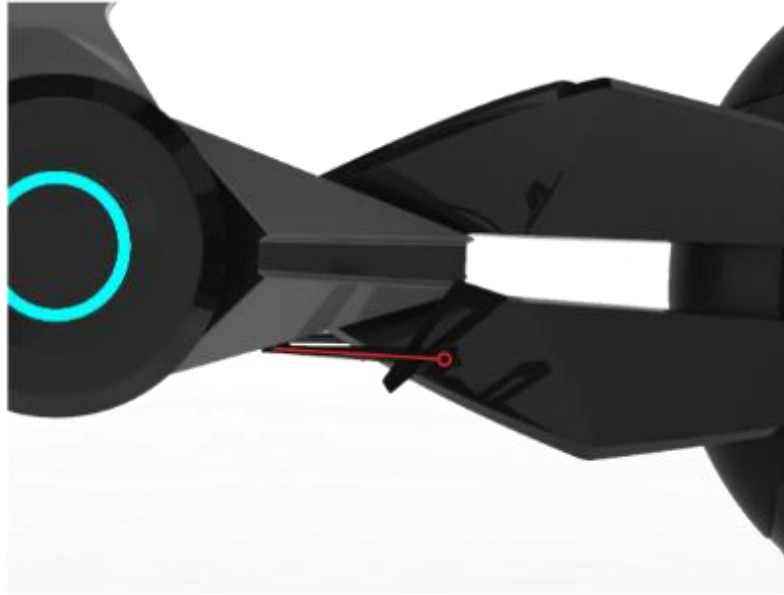

Off-road

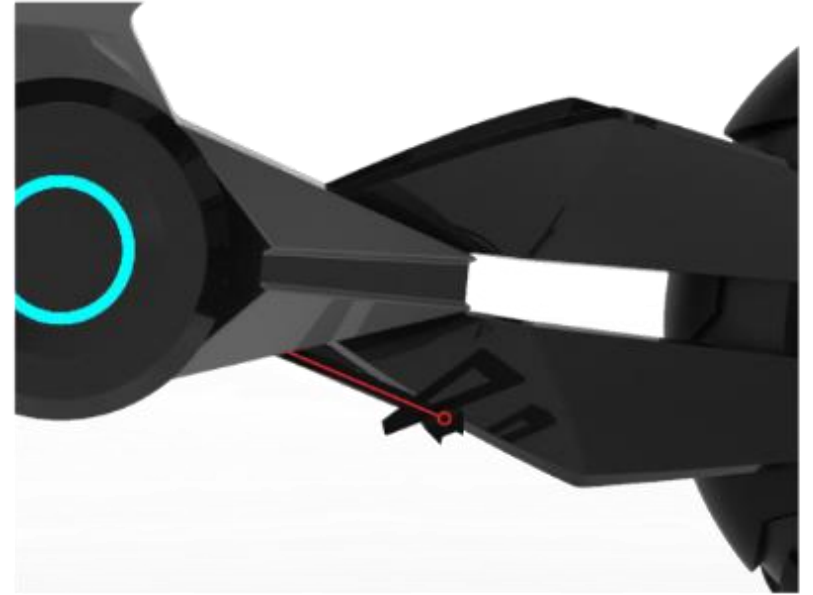

# Final design

## Details

Tyre tread for urban  
and race modes

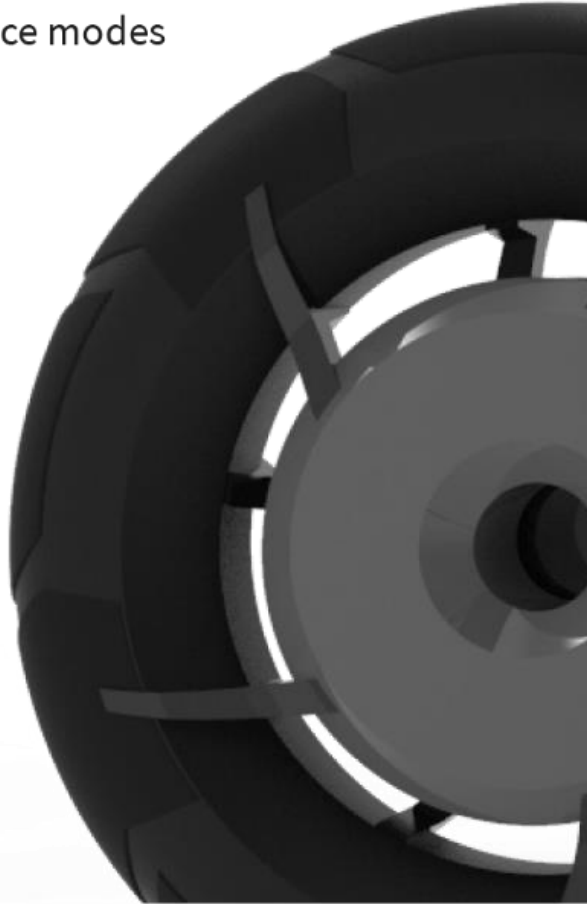

Tyre tread for  
off-road mode

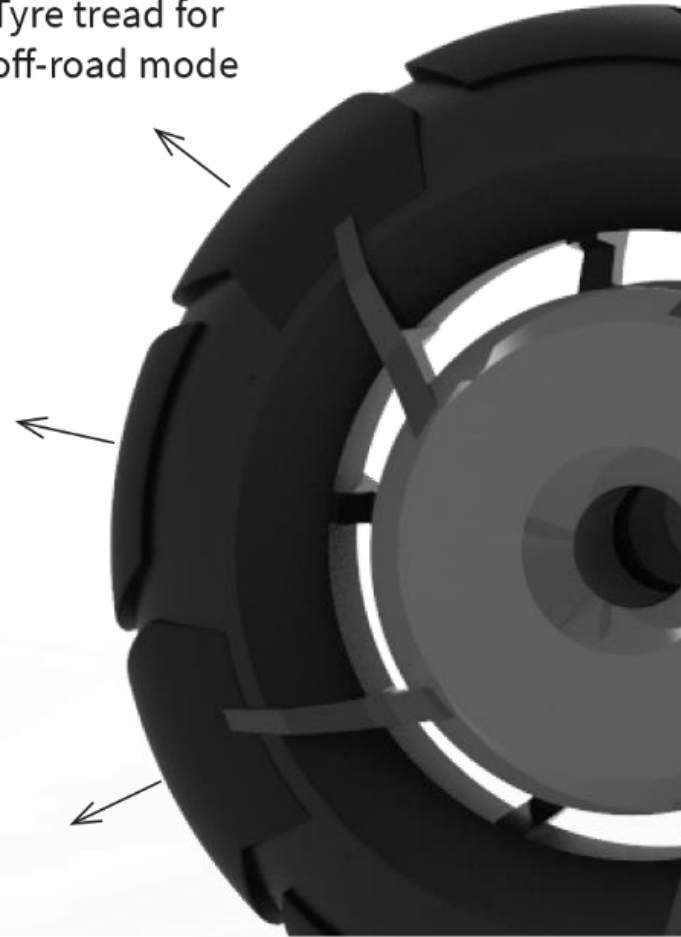

# Final design

## Details

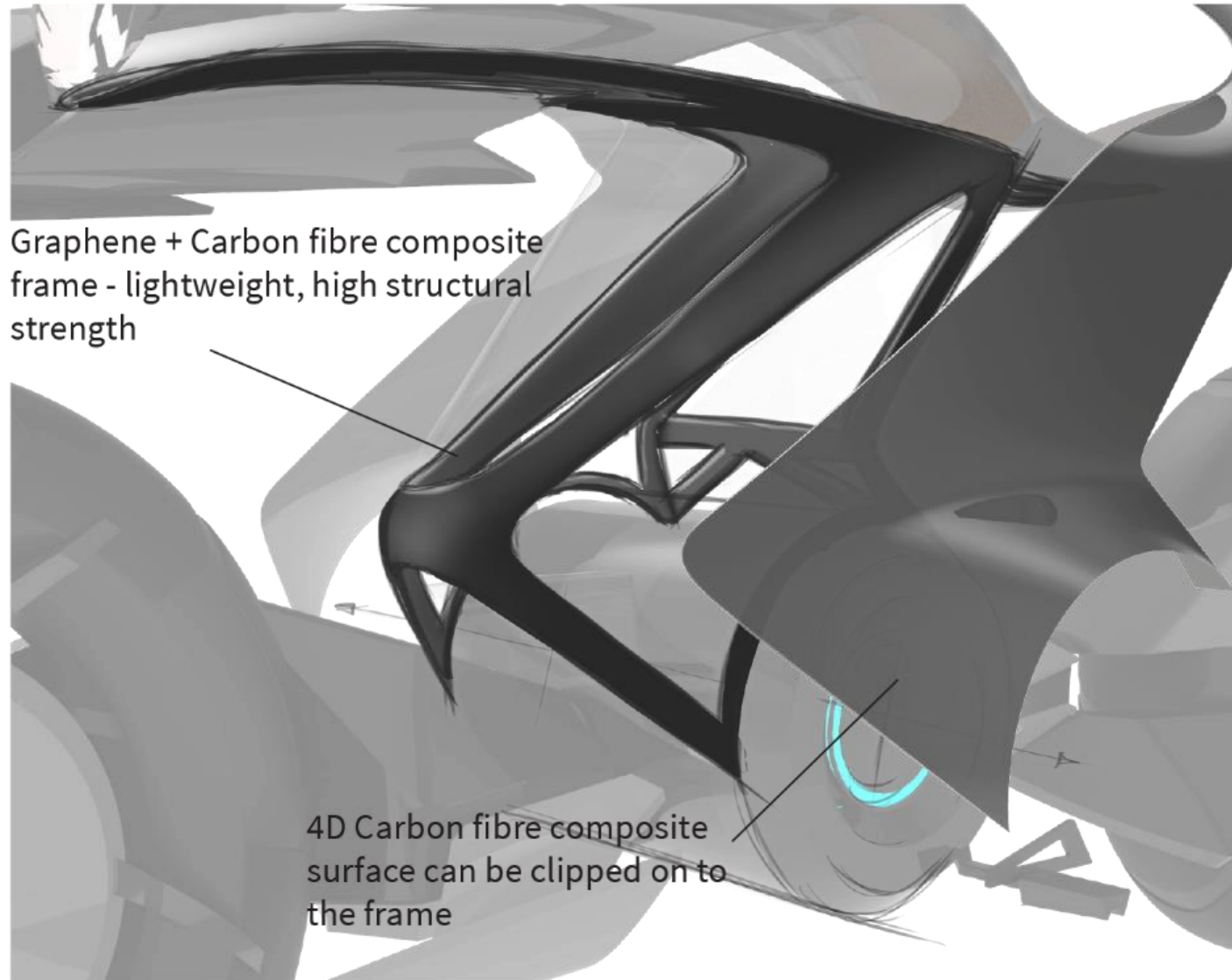

# Final design

## Details

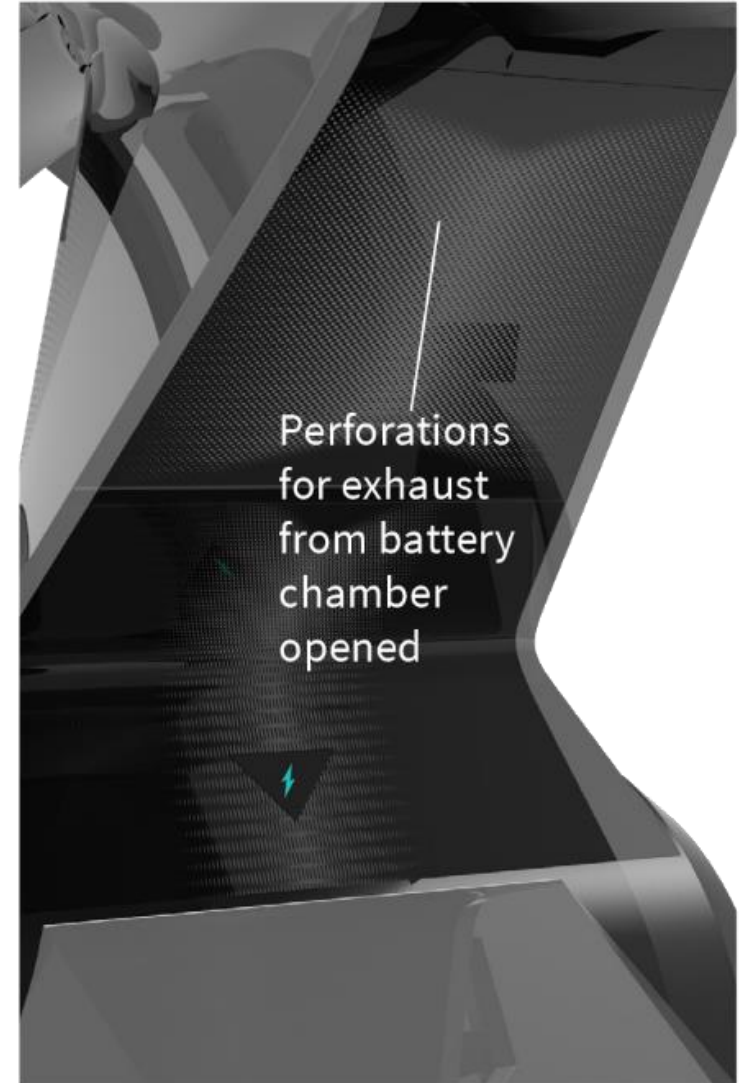
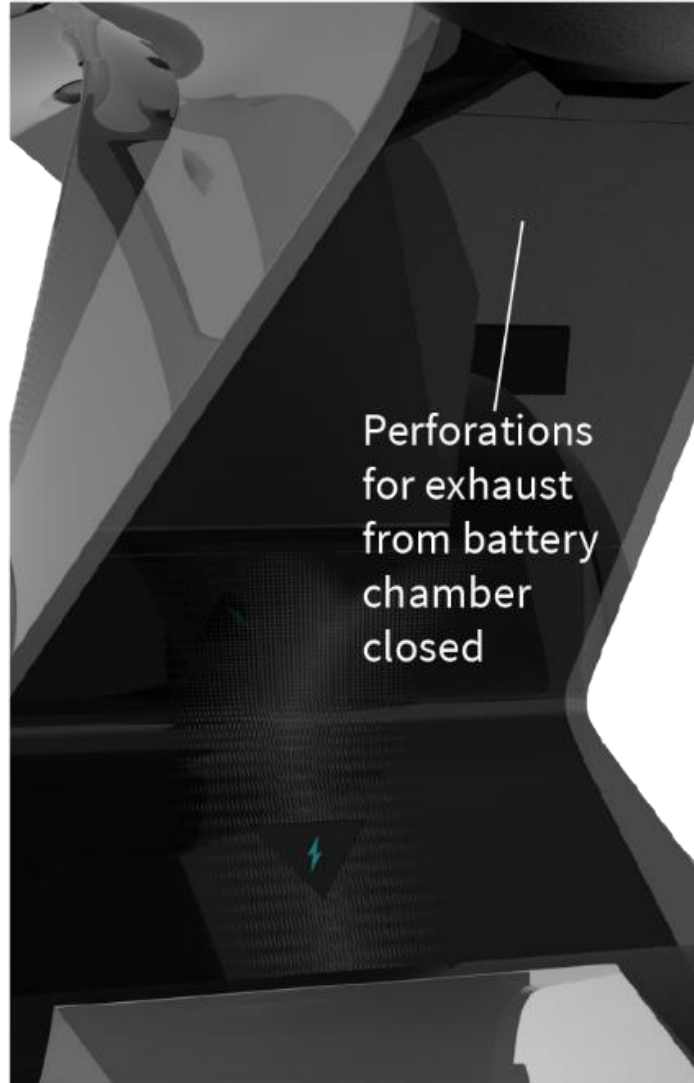

# Final design

## Details

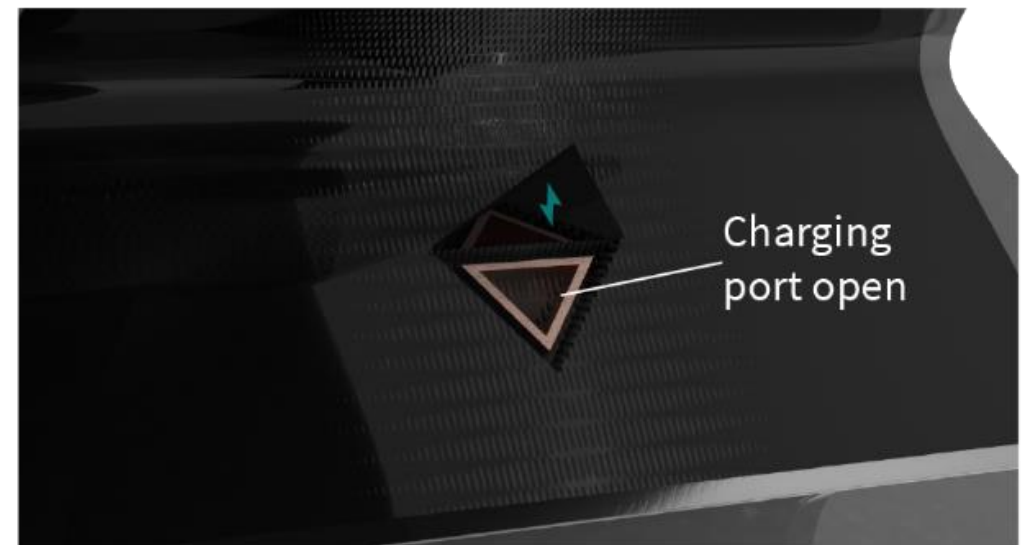

Final design



Customizability



Final design

Urban



Final design

Race



Final design

Off-road





Fin.

# References

- <http://society2030.umich.edu/>
- <https://www.nap.edu/read/24876/chapter/1#8>
- <https://www.cbinsights.com/research/future-factory-manufacturing-tech-trends/>
- <https://www.weforum.org/agenda/2016/11/is-this-how-well-make-things-in-2030/>
- <https://www.bbva.com/en/science-technology/technologies/>
- <https://www.quantumrun.com/future-timeline/2030/future-timeline-subpost-technology>
- <https://www.socialmediatoday.com/news/21-technology-tipping-points-we-will-reach-by-2030-infographic/523221/>
- <https://ferasantoonreports.com/innovations-technology-humanity-will-reach-2030/>
- <https://www.weforum.org/agenda/2016/11/8-predictions-for-the-world-in-2030/>
- <https://futuristspeaker.com/business-trends/driverless-highways-creating-cars-that-talk-to-the-roads/>
- <http://www.et3.com/>
- <https://en.wikipedia.org/wiki/2030>
- <https://futuristspeaker.com/business-trends/33-dramatic-predictions-for-2030/>
- <http://www.vtppi.org/avip.pdf>
- <https://www.futuretimeline.net/21stcentury/2030.htm>
- <https://www.weforum.org/agenda/2017/10/tech-life-predictions-for-2030/>
- <https://www.designer-daily.com/30-awesome-futuristic-product-concepts-26509>
- <https://www.thecut.com/2016/10/12-futuristic-products-that-might-change-your-life.html>
- <https://www.popsci.com/science/article/2011-03/gallery-six-ways-biomimicry-reshaping-future#page-2>
- <https://www.citylab.com/life/2016/09/a-skyscraper-made-of-bones-how-biomimicry-could-shape-the-cities-of-the-future/497969/>
- <https://www.biobasedworldnews.com/what-is-biomimicry-borrowing-natures-blueprints-for-a-sustainable-future>
- <http://publications.lib.chalmers.se/records/fulltext/255400/255400.pdf>
- [https://www.washingtonpost.com/graphics/2018/business/global-income-calculator/?noredirect=on&utm\\_term=.47e35bfe8830](https://www.washingtonpost.com/graphics/2018/business/global-income-calculator/?noredirect=on&utm_term=.47e35bfe8830)
- <https://www.brookings.edu/blog/future-development/2018/09/27/a-global-tipping-point-half-the-world-is-now-middle-class-or-wealthier/>
- [https://www.washingtonpost.com/news/innovations/wp/2017/05/03/in-the-future-virtual-assistants-will-not-only-take-orders-theyll-have-ideas-of-their-own/?utm\\_term=.aeb7e812bbbe](https://www.washingtonpost.com/news/innovations/wp/2017/05/03/in-the-future-virtual-assistants-will-not-only-take-orders-theyll-have-ideas-of-their-own/?utm_term=.aeb7e812bbbe)
- <https://medium.com/@thirtysevenclick/future-people-d7457bc93f3>
- <https://www.thehindubusinessline.com/economy/indias-ev-goals-are-being-realised-on-two-wheels-not-four/article25995048.ece>
- <http://www.autocarpro.in/news-national/indias-wheeler-industry-targets-sustainability-merges-focus-vision-27849>
- <https://www.goldsteinresearch.com/pressrelease/with-80-revenue-share-asia-pacific-region-dominates-global-two-wheelers-market>
- <https://auto.economictimes.indiatimes.com/news/two-wheelers/motorcycles/why-premium-motorcycle-makers-are-lining-up-in-india-/66903243>
- <https://www.oecd.org/futures/49093502.pdf>
- <https://library.cqpress.com/cqresearcher/document.php?id=cqresrre2017120100>
- <https://www.businessinsider.in/Heres-who-comes-after-Generation-Z-and-theyre-going-to-change-the-world-forever/articleshow/50060434.cms>
- <http://blog.elas.uk.com/blog/mental-health-problems-increase-2030>
- [https://www.researchgate.net/publication/319909070\\_From\\_mass\\_customization\\_to\\_product\\_personalization\\_in\\_automotive\\_industry\\_potentials\\_of\\_industry\\_40](https://www.researchgate.net/publication/319909070_From_mass_customization_to_product_personalization_in_automotive_industry_potentials_of_industry_40)
- [https://www.academia.edu/34551998/MASS\\_CUSTOMIZATION\\_IN\\_THE\\_AUTOMOTIVE\\_INDUSTRY\\_BETWEEN\\_REALITY\\_AND\\_SUPPLY\\_CHAIN\\_CHALLENGES\\_A\\_CASE\\_STUDY\\_ON\\_MINI?](https://www.academia.edu/34551998/MASS_CUSTOMIZATION_IN_THE_AUTOMOTIVE_INDUSTRY_BETWEEN_REALITY_AND_SUPPLY_CHAIN_CHALLENGES_A_CASE_STUDY_ON_MINI?)
- <https://www.cadcrowd.com/blog/biomimicry-product-design-inspired-by-nature/>
- <http://www.csrwire.com/blog/posts/1379-what-is-the-future-for-biomimicry>
- <https://www.apartmenttherapy.com/the-home-of-tomorrow-is-this-the-future-of-furniture-design-246553>
- <https://www.weforum.org/agenda/2018/10/mapping-the-world-s-new-megacities-in-2030/>
- <https://www.weforum.org/agenda/2018/10/these-are-the-megacities-of-the-future/>
- <https://www.smartcitiesdive.com/ex/sustainablecitiescollective/vertical-city-concept-how-live-sustainable-life/1163942/>
- <https://www.planetizen.com/blogs/101788-vertical-cities-can-mega-skyscrapers-solve-urban-population-overload>
- <https://www.siemens.com/innovation/en/home/pictures-of-the-future/energy-and-efficiency/future-of-energy-smart-grids.html>
- <https://medium.com/@irapua.ribeiro/what-is-a-smart-grid-and-why-is-it-the-future-8941359d2dc8>
- <https://balkangreenenergynews.com/by-2035-smart-grids-to-be-financed-with-eur-10-billion/>
- <https://www.woodmac.com/news/feature/global-energy-transition/>
- <https://www.archdaily.com/900933/dubai-plans-for-one-quarter-of-buildings-to-be-3d-printed-by-2025>
- <https://www.azom.com/article.aspx?ArticleID=12387>
- <https://all3dp.com/1/4d-printing/>
- <https://selfassemblylab.mit.edu/4d-printing>
- <https://www.theverge.com/ces/2017/1/4/14172006/hyundai-mobility-concept-smart-home-driverless-car>
- <https://www.treehugger.com/urban-design/honda-iemobi-mobile-autonomous-living-room-and-future-self-driving-cars.html>
- <https://www.clei.co.uk/clei/doc.htm>
- <https://clemararoundthecorner.com/2016/10/23/table-transformable-design-boulon-blanc/>
- <http://www.tuvie.com/limbo-flexible-smartphone-concept-by-jeabyun-yeon/>
- <https://www.theverge.com/2017/3/7/14841324/airbus-concept-car-drone-train-geneva-motor-show>
- <https://www.mckinsey.com/industries/automotive-and-assembly/our-insights/disruptive-trends-that-will-transform-the-auto-industry>
- <https://eu-smartcities.eu/sites/default/files/2018-03/pwc-five-trends-transforming-the-automotive-industry.compressed.pdf>
- <http://www.un.org/en/development/desa/news/population/2015-report.html>
- <https://www.livepopulation.com/population-projections/world-2035.html>
- <https://techcrunch.com/2017/04/19/facebook-brain-interface/>
- <https://interestingengineering.com/generation-alpha-the-children-of-the-millennial>