

Reinterpreting poles as digital assets to enhance Value of road infrastructure

Submitted in partial fulfilment of the requirements

Of the degree of Master of Design

by

P Sri Hari

Roll No. 176130008

Supervisor:

Prof. P Kumaresan



Industrial Design Centre

INDIAN INSTITUTE OF TECHNOLOGY BOMBAY

(2019)

Approval Sheet

This dissertation entitled “*Reinterpreting poles as digital assets to enhance Value of road infrastructure*” by **P Sri Hari** is approved for partial fulfilment for the postgraduate degree in Industrial Design.

Prof. Kumaresan
[Project guide]



Internal Examiner:



External Examiner:

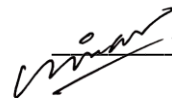

NIRAN SHAH

Chairperson:

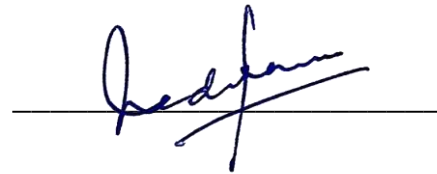

Declaration

I declare that this written submission represents my ideas in my own words and where other thoughts or words have been included, I have adequately cited and referenced the original sources. I also declare that I have adhered to all the principles of academic honesty and integrity and have not misrepresented or fabricated or falsified any idea/ data/ fact/ source in my submission. I understand that any violation of above will cause for disciplinary action by the Institute and can also evoke penal action from the sources which have thus not been properly cited or from whom proper permission has not been taken when needed.

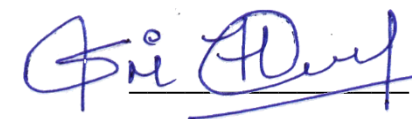

P Sri Hari

176130008

Acknowledgement

Firstly, I would like to express my thanks and gratitude to my project guide Prof. P Kumaresan, without whom this project would not have been possible. I would also like to thank POC lab for helping me out with my project by providing necessary equipment.

Lastly, I would also like to thank studio staff for helping me out with prototypes and my family and friends for being my support during project time.

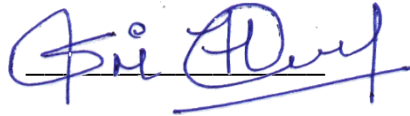

P Sri Hari

Abstract

Urban areas are expected to contribute 75% of India's GDP AND house 40% of India's population by 2030. Smart cities development is a step in that direction. A smart city employs Internet of things (IoT) sensors to perceive data and use the collected data to manage assets and resources efficiently. Poles are vital infrastructure and span across most parts of the cities, but serves limited applications like Lighting or Signage. Poles of the future serve as ambidextrous city nodes capable of real time monitoring of the entire city. These poles accommodate equipment for real-time data gathering on roads to make infrastructure more responsive according to the specific needs and achieve sustainability goals by deploying equipment that can naturally replenish the energy to meet the demand for equipment operation. Thus the value addition by redesigning the existing pole infrastructure helps to realise the vision for future smart cities. The humble street pole of the past may soon become the most valuable asset in the cities infrastructure.

KEYWORDS: Vertical axis wind turbine, Kinetic tiles, Ducting chamber, Renewable energy, Hot spot, Surveillance, Public addressing system, Flange plate, International protection marking.

Contents

| | | | |
|-------------------------------------|-----------|----------------------------------|-----------|
| 1. Introduction | 1 | | |
| 1.1 Background | | | |
| 1.2 Purpose | | | |
| 1.3 Delimitations | | | |
| 2. Literature survey | 6 | | |
| 2.1 Types of information roads | | | |
| 2.2 Components of the smart pole | | | |
| 2.3 Parallel products in the market | | | |
| 2.4 Usage scenario | | | |
| 2.5 Mode of operation | | | |
| 3. Design framework | 22 | | |
| 3.1 Design statement | | | |
| 3.2 Design brief | | | |
| | | 3.3 Mood board | |
| | | 3.4 Mind map | |
| | | 3.5 Product autopsy | |
| | | 3.6 Volumetric data | |
| | | 3.7 Sketches | |
| | | 3.8 Concept generation | |
| | | 3.9 Final design | |
| | | 3.10 Branding and customization | |
| | | 3.11 Prototypes | |
| | | 3.12 Materials and manufacturing | |
| | | 3.13 Pole placement | |
| | | | |
| | | 4 References | 58 |

List of Figures

Figure 1.1 Road network in India

Figure 1.2 Applications of smart poles

Figure 2.1 Micro cell

Figure 2.2 VAWT

Figure 2.3 Photovoltaic system

Figure 2.4 Components of LED

Figure 2.5 Dot matrix display

Figure 2.6 LED display

Figure 2.7 Dark fighter camera, ANPR camera, Dome camera, PTZ camera

Figure 2.8 A Public announcement system on a ship

Figure 2.9 Touchscreen interface

Figure 2.10 Various kinds of sensors

Figure 2.11 Ducting/ Access chamber

Figure 2.12 Features in Obama smart pole

Figure 2.13 Features in Philips and American tower smart pole

Figure 2.14 Features in Energasia smart pole

List of Tables

Table 1.1 Indian road network as administered by various government authorities

Table 2.1 Micro cell specifications

Table 2.2 VAWT specifications

Table 3.1 Volumetric data of components

Chapter 1

Introduction

1.1 Background

In India, cities accommodate about 31% of the population and contribute 63% of GDP (according to Census 2011). By 2030, urban areas are expected to contribute 75% of GDP and house 40% of the population. It requires comprehensive development of social, physical, economic, and institutional infrastructure. These factors contribute in attracting investment and people thereby improving the quality of life and, set into motion the cycle of growth and development. The Smart Cities Mission is a new initiative by the Government of India to enhance the quality of life of people and stimulate economic growth by harnessing technology as a means to create smart solutions for future challenges citizens are expected to face. Induction of Smart Cities program is a step in that direction. A smart city employs different types of sensors to collect data and use these data to manage resources and assets efficiently. Poles are vital infrastructure and span across most parts of the cities, but serves limited applications like Lighting or Signage. These poles can accommodate equipment for real-time data gathering on roads to make infrastructure more responsive according to the specific needs and achieve sustainability goals by deploying equipment that can naturally replenish the energy to meet the demand for equipment operation. Thus the value addition by redesigning the existing pole infrastructure helps to realize the vision for future smart cities.

1.2 Purpose

India has a road network spanning over 5,903,293 kilometers (as of 31 January 2019). The quantitative density of India's road network is 1.70 km of roads per square kilometer of land. Adjusted to its current population, India has 4.63 km of roads per 1000 people. Indian roads are a mix of modern highways and narrow, unpaved roads. Road transport has gained its importance over the years and is critical to the country's development. India's road network handles over 85 percent of total passenger traffic and 65 percent of its freight. Roads have a wider potential apart from driving economy when coupled with equipment like smart poles. With a widespread distribution across the roads, poles have a potential to gather real time data through devices like sensors and cameras. Thus, smart pole infrastructure can be projected as technological foundations for data gathering across the country. The smart pole infrastructure can be used as a platform to host a variety of applications like environmental monitoring, public safety and security, public Wi-Fi, digital signages, electric vehicle charging, public addressing system, street lighting, municipal asset monitoring and energy harvesting.

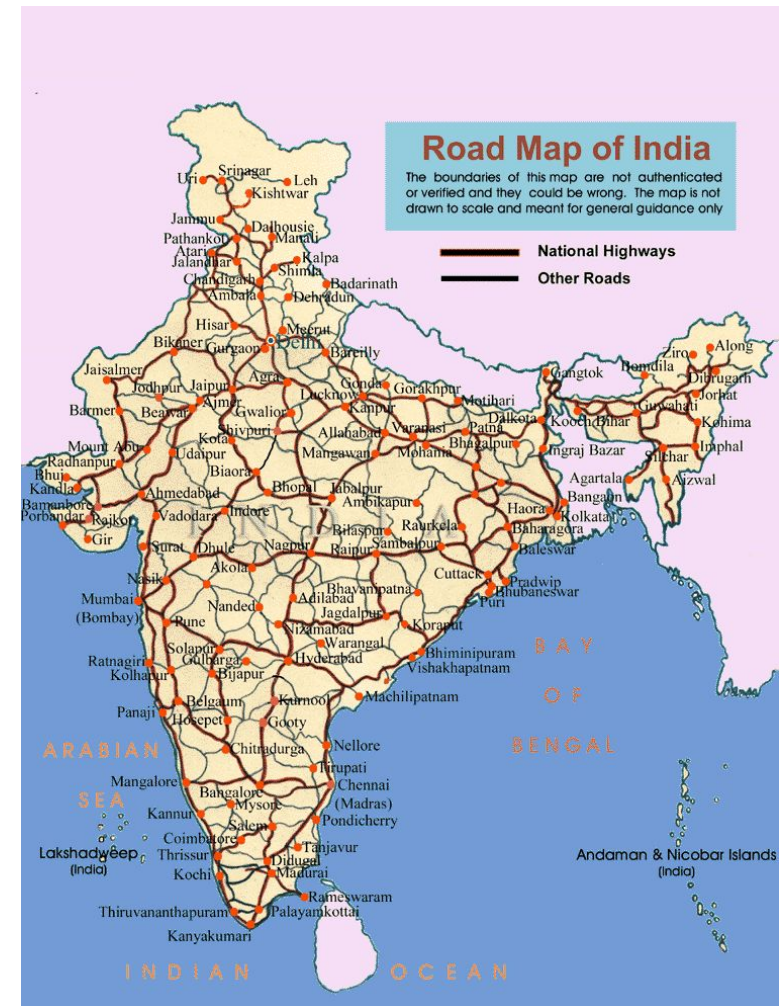

Figure 1.1 Road network in India



Figure 1.2 Applications of smart poles

Table 1.1 Indian road network as administered by various government authorities (as on 31 march 2016)

| Road classification | Authority responsible | Length(Kms) | Share of network length |
|----------------------------|---|--------------------|--------------------------------|
| National Highways | Ministry of Road Transport and Highways | 101,011 | 1.80 % |
| State highways | Public Works Department of State/Union Territory | 176,166 | 3.14 % |
| Other PWD roads | Public Works Department of State/Union Territory | 561,940 | 10.03 % |
| Rural roads | Panchayats, JRY and PMGSY | 3,935,337 | 70.23 % |
| Urban roads | Local governments and municipalities | 509,730 | 10.10 % |
| Project roads | Various State/Union territory government departments, | 319,109 | 5.70 % |
| Total | | 5,603,293 | 100 % |

1.3 Delimitations

The project is limited to form generation for smart pole to integrate various technological components like mini cell tower, vertical axis wind turbine, solar panels, video cameras, smart lights, public addressing system, sensors, and digital signages. It doesn't involve the development of the above mentioned technologies. The technologies are integrated in their existing forms without any alterations. The designing process involves exploration of various form factors to integrate these technologies together and improve the usability of existing pole. The product is intended for city roads and can be further extended to highways and rural roads by altering few components. The smart pole is modular in nature and can be customized based on context like highways, city roads or rural roads. Additional hardware is to be integrated with the smart pole in context with the application.

Chapter 2

Literature Survey

Street poles are essential elements of urban environment, commonly used for street lighting and signages. It creates a sense of safety by improving visibility for motorists and citizens at dark. Most of the world's roads are still lit by technology decades older. In recent years most cities adopted to LED's to achieve sustainability goals. Switching to LED is not enough to meet the challenges of next generation cities. The future of cities is data driven and street poles play a prominent role to achieve the goals of future cities by incorporating data collection devices like sensors and cameras. The pole infrastructure can be used as a platform to serve many applications like public surveillance, environmental monitoring, traffic management, energy generation, smart parking and wireless connectivity. The street poles of the future serve as ambidextrous city nodes capable of monitoring the entire city in real time. The humble street poles of the past may soon become the most valuable assets of cities infrastructure.

2.1 Types of information on road

2.1.1 Surveillance

- Monitoring municipal assets
- Selective vehicles detection
- Motion detection

2.1.2 Traffic data

- Traffic congestion data
- Traffic patterns
- Parking data
- Journey time measurement
- Speed detection
- Traffic defaulters
- Selective vehicle detection

2.1.3 Disaster monitoring

- Flood detection
- Rainfall monitoring
- Cyclone detection

2.1.4 Environmental data

- Temperature
- Moisture
- Rain gauging
- Dry/ wet sampling
- Wind speed/ direction
- Atmospheric pressure
- Solar radiation

2.2 Components of the smart pole

2.2.1 Microcells/ Mini cell tower:

Microcells provide connectivity to internet enabled devices like smartphones, tablets and laptops in a small form factor. Microcells are cheap, smaller and easy to maintain. Usually employed at congested urban centers to expand the network coverage. Macro cells are soon replaced by microcells due to zoning and radiation regulations.

Table 2.1 Micro cell specifications

| | |
|-------------------|----------------|
| Transmit power | 30 dBm |
| Coverage distance | 500 meters |
| Access mode | Open to public |
| Installation | By operator |
| Connectivity | X2 interface |



Figure 2.1 Micro cell

2.2.2 Vertical axis wind turbine:

The vertical axis wind turbine (VAWT) has rotor shaft set transverse to the wind and components located at the mounting base. VAWT axis is vertical to the ground and perpendicular to the wind streamlines. VAWT function better than HAWT in turbulent winds. VAWTs offer advantages like better scalability to large sizes, lower turbine center of gravity, and reduced machine complexity.

Table 2.2 VAWT specifications

| | |
|---------------------|------------------|
| Blade material | Aluminum alloy |
| Started wind speed | 1.5 m/s |
| Survival wind speed | 45 m/s |
| Rated Wind speed | 12 m/s |
| Rated voltage | 24V |
| Rated power | 300W |
| Wind wheel diameter | 0.45 meters |
| Blades quantity | 12 pcs |
| Generator | Maglev generator |

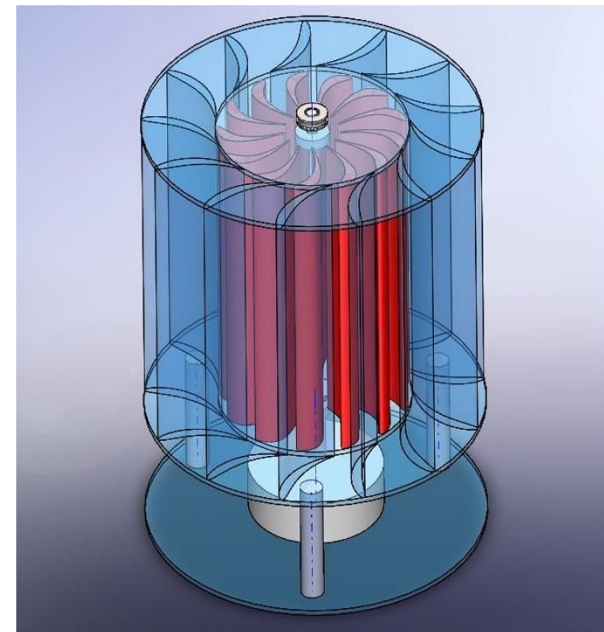

Figure 2.2 VAWT

2.2.3 Solar panels:

Solar panels/ Photovoltaic panels absorb light from the sun as a source of energy to generate electricity. Photovoltaic modules work on the principle of photovoltaic effect i.e. to generate electricity using photons from the Sun. The modules use wafer based crystalline silicon cells. Most modules are rigid, but flexible modules are also available. The cells must be connected electrically in parallel to provide a desired current or in series to achieve a desired output voltage. Photovoltaic modules produce electricity from a range of light frequencies, but doesn't cover the entire solar frequency range. Hence, much of the incident sunlight cannot be transformed into energy by solar modules. A photovoltaic system includes an inverter, array of photovoltaic modules, interconnection wiring to connect modules, a battery pack for storage and solar tracking mechanism (optional). The most efficient solar modules that are mass produced have power density of up to 175 W/m².

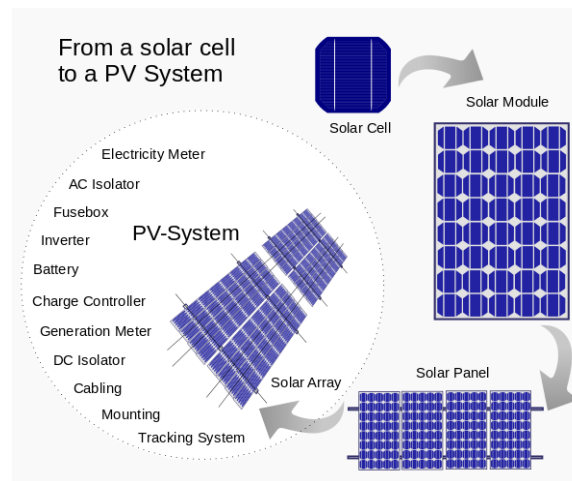

Figure 2.3 Photovoltaic system

2.2.4 LED Lighting:

An LED produces light using one or more light-emitting diodes (LEDs). LEDs have a lifespan many times longer than incandescent lamps, and are more efficient than fluorescent lamps. LED chips can emit approximately up to 300 lumens per watt. LED driver circuit is required for LED lamps when operated from mains power lines. Many LEDs use only about 10% of the energy used by an incandescent lamp. Unlike fluorescent lamps, LEDs have no warm-up delay i.e. they come to full brightness immediately when switched on. The life expectancy does not reduce with frequent switching on and off as in the case of fluorescent lighting. LEDs run on direct current (DC) and contain a circuitry for converting the AC into DC. LEDs are different from other light sources by being more directional, i.e., emitting a narrower beam of light. LED lamps include heat dissipation elements such as cooling fins and heat sinks to prevent reduced light output and premature failure due to higher temperature.

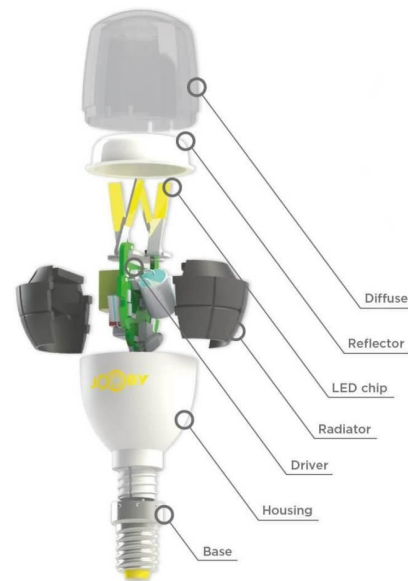

Figure 2.4 Components of LED

2.2.5 Variable message sign:

A variable message sign is an electronic display used on roadways to give travelers information like traffic congestion, speed limits, parking guidance, alternative routes, and traffic conditions. Earlier variable message signs included trilons (rotating prisms) to change the message being displayed. These were later replaced by dot matrix displays using fiber optic technology. LED displays have replaced the dot matrix displays and have the ability to display graphics and colored text.

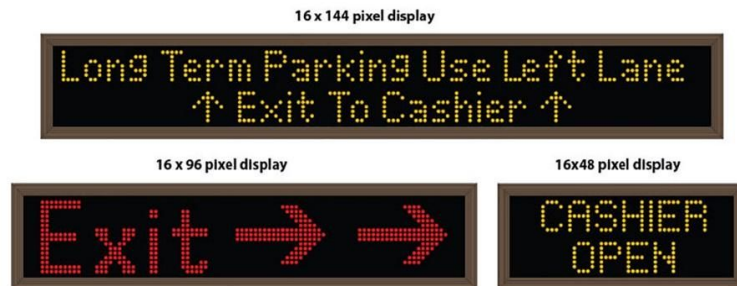

Figure 2.5 Dot matrix display



Figure 2.6 LED display

2.2.6 Surveillance cameras:

Surveillance plays an important role in maintaining law and order in the society and cameras are vital components of this system. Variety of CCTV cameras are available in the market which suit different situations.

Dark Fighter Technology Camera: Capability to pick up colored images in very low-light conditions and can be used in the day and night with optimal performance capabilities. It doesn't require an external light source making them perfect for night time security surveillance.

ANPR Cameras: ANPR (Automatic Number Plate Recognition) cameras capable of reading and storing data of registration plates. The applications include hotel overstay management, tolling and car parking.

Dome Camera: Most commonly used cameras for surveillance. The shape of the camera creates a difficulty for onlookers to predict the camera facing, creating an air of uncertainty.

PTZ camera: Pan/tilt/zoom cameras allow the camera to be moved up and down (tilting), left or right (panning), and allow the lens to be zoomed in/out. Usually deployed in situations where a surveillance specialist is operating the security system.



Figure 2.7 Dark fighter camera, ANPR camera, Dome camera, PTZ camera

2.2.7 Public addressing systems (PAS):

PAS comprises of amplifiers, loudspeakers, microphones, and other equipment like mixers. The volume (loudness) of a human voice is amplified and then played through loudspeakers. PA systems are used in public venue that requires sufficient audibility of announcer at a distance over a large area.

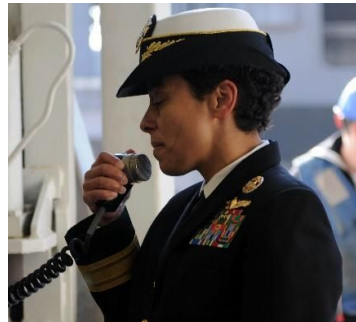

Figure 2.8 A Public announcement system on a ship

2.2.8 Touchscreen Interface

A touchscreen interface is an input device layered on an electronic visual display. A user can control the information processing through simple touch gestures by one or more fingers.

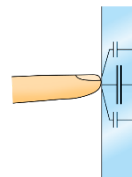

Figure 2.9 Touchscreen interface

2.2.9 Sensors:

A sensor is a device or module to detect changes or events in the environment and forward the information to other electronic components for further processing. Sensitivity of a sensor indicates the sensor's response to the input quantity being measured. Technological progress in MEMS technology allows sensors to be manufactured on a microscopic scale.



| | | | | | |
|---|--|---|---|--|--|
|  JoyStick XY |  Flame |  RGB LED |  Heartbeat |  Light Cup |  Hall magnetic |
|  Relay |  Linear Hall |  SMD RGB |  7Color flash |  Tilt switch |  TEMP 18B20 |
|  Big sound |  Touch |  Two-color |  Laser emit |  Ball switch |  Analog temp |
|  Small sound |  Digital temp |  Two-color |  Button |  photoresistor |  TR emission |
|  Tracking |  Buzzer |  Reed switch |  Shock |  temp and humidlty |  IR receiver |
|  Avoid |  Passive buzzer |  Mini Reed |  Rotary encoders |  Analog Hall |  Tap module  Light blocking |

Figure 2.10 Various kinds of sensors

2.2.10 Modular storage:

Modular racks made of ABS are used to host a range of customized sensors based on client preference. Each compartment is independent with a lockable door. The compartments can be scaled along the length of the pole to meet future requirements.

2.2.11 Mounting pole

An extruded aluminum section is used to host the range of components for the smart poles. Holes are laser cut to drive the cables for electronic components. The section has 5mm thickness and is weather proof coated with Acrylic poly siloxane.

2.2.12 Ducting chamber

The ducting/ Access Chamber has stackable sections to form a chamber of any depth. It has twin wall design with horizontal and vertical support ribs. The vertical ribs provide vertical compressive strength against the loads by vehicles passing over and the horizontal rib offers resistance against side wall loads from ground heave.

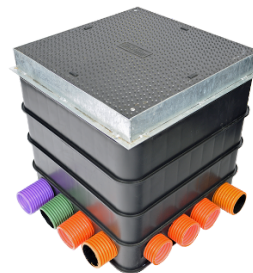

Figure 2.11 Ducting/ Access chamber

2.3 Parallel products in the market

2.3.1 Obama energies pole

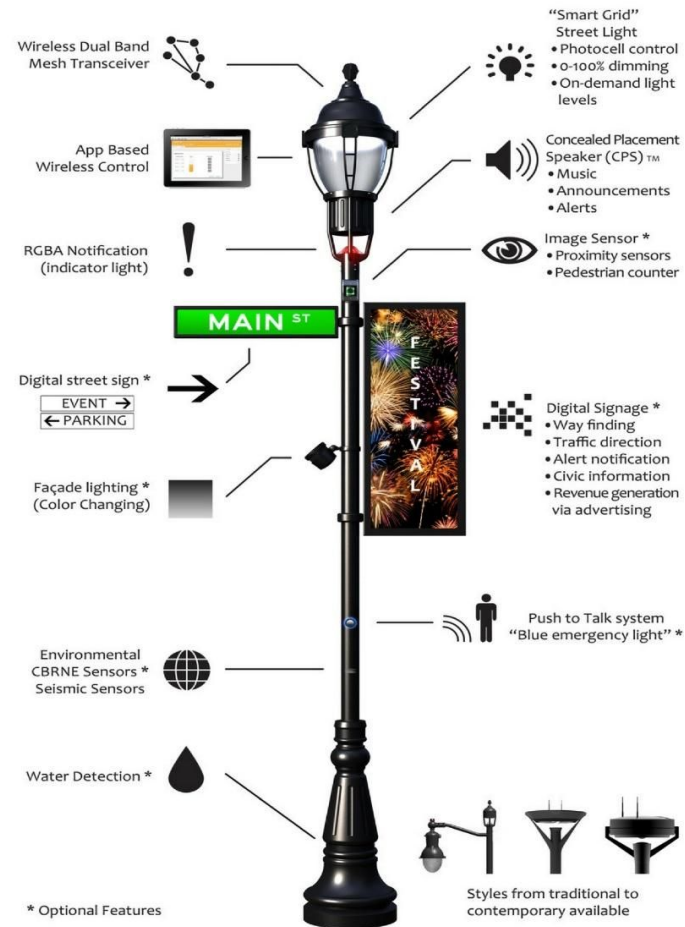

Figure 2.12 Features in Obama smart pole

2.3.2 Philips and American tower smart pole

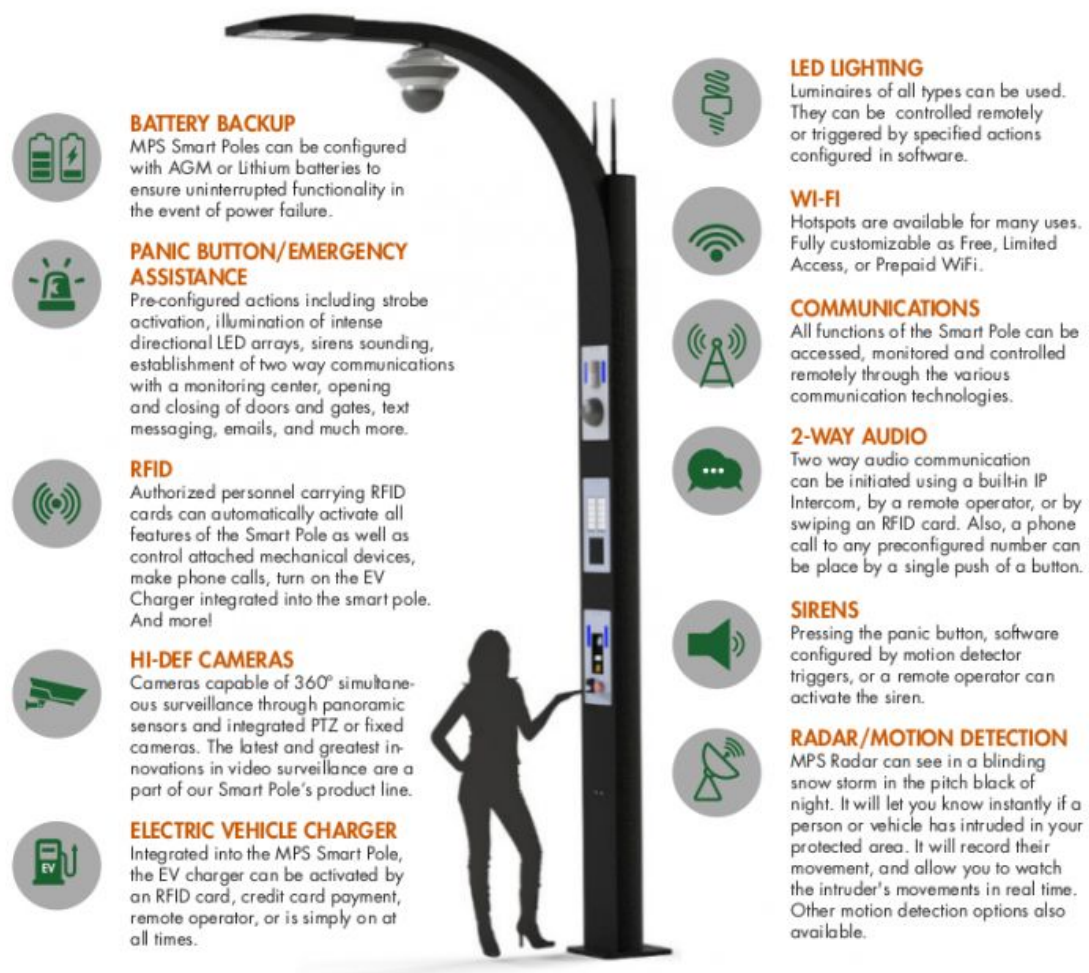

Figure 2.13 Features in Philips and American tower smart pole

2.3.3 Energasia smart pole

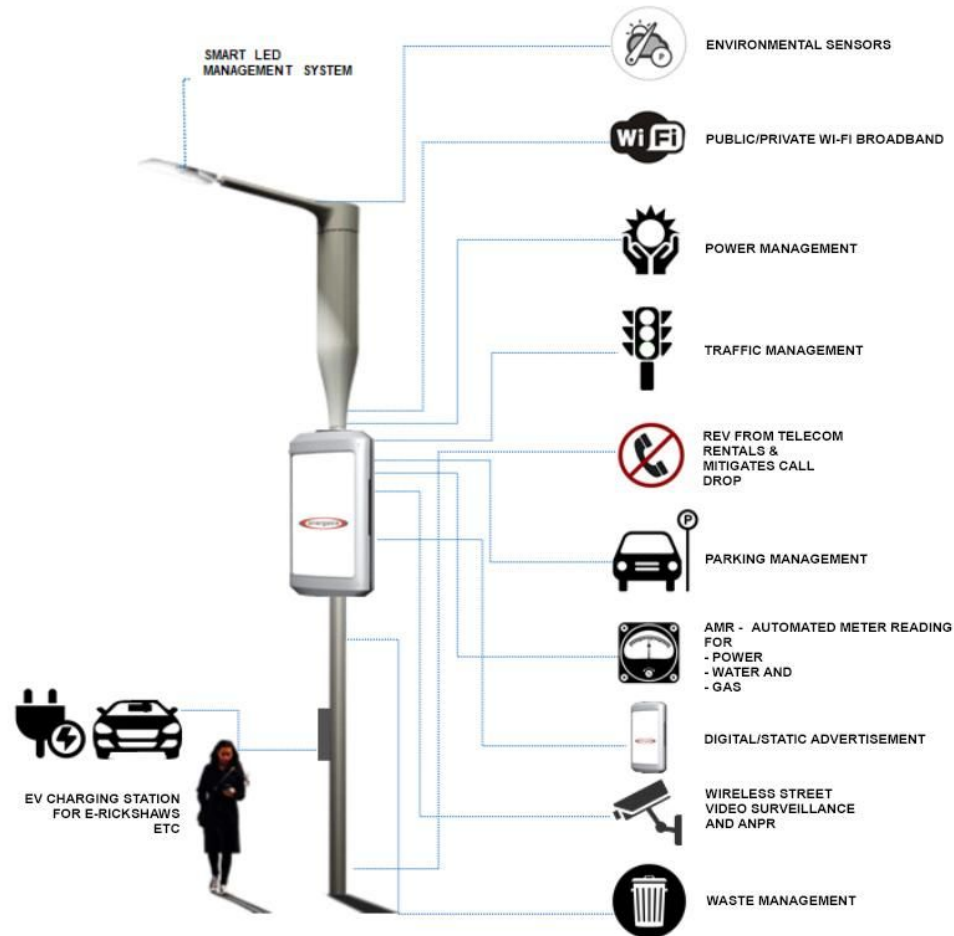

Figure 2.14 Features in Energasia smart pole

2.4 Usage scenario

The smart pole can be used in any of the following scenarios with necessary equipment installed:

City roads:

In cities, smart poles can be used as nodes to monitor the entire city in real time. Poles with variable message displays can be used to generate revenue for the municipality. The wireless connectivity in dense urban areas can be enhanced using micro cell towers. Parking data can be collected for parking management.

Highways:

On highways, smart poles can be used to collect information like selective vehicle detection, journey time measurements, traffic patterns and generate clean energy to host chargers for electric vehicles.

Border roads:

On border roads the smart poles can be used for surveillance to detect enemy movement. Electronic warfare equipment can be hosted to impede enemy assaults.

Rural roads:

On rural roads environmental data like air purity, humidity, solar radiation, etc., can be gathered. Telecommunication connectivity can be improved in remote areas.

Walkways:

On walkways poles can be used for intelligent lighting, festive lights, advertisement display and play music. Kinetic tiles can be used to generate electricity.

2.5 Mode of operation

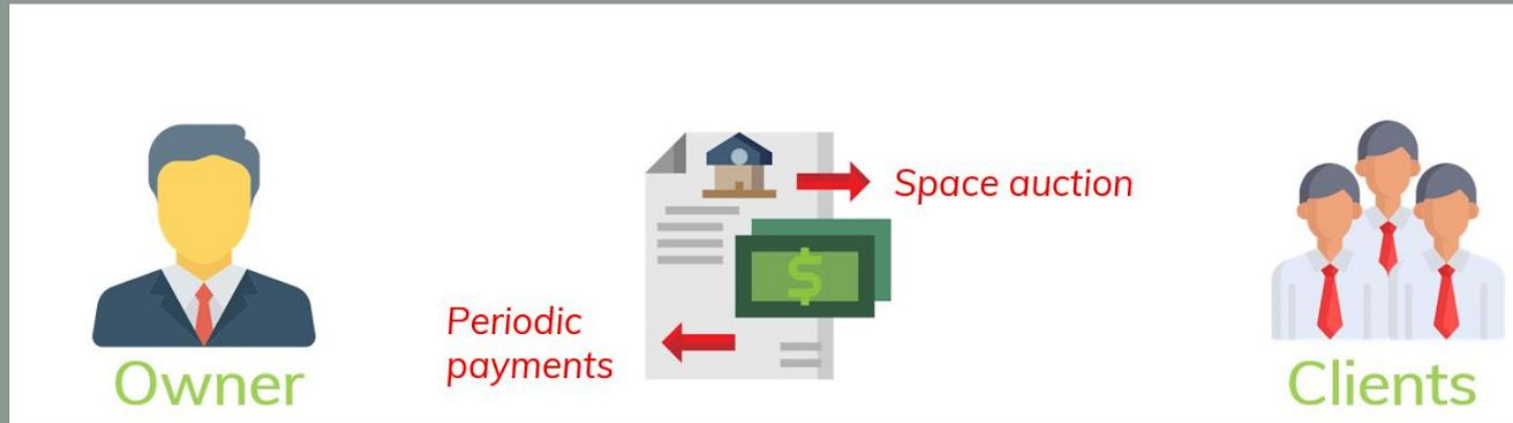

- Ministry of road transport and highways
- Public works department
- Municipal corporations

- Telecommunication operators
- Advertisement agencies
- Law enforcement organizations
- Environment organizations
- Research labs

Chapter 3

Design Framework

3.1 Design statement

To design a smart pole to host range of electronic components for real time data gathering and clean energy generation.

3.2 Design brief

Project overview

Designing a pole to accommodate equipment for real time data gathering on roads to make infrastructure more responsive according to the specific needs of future cities. If possible making the pole self-sufficient to carry its operations by replenishing energy from the environment.

Design requirements

- a. Modularity
- b. Optimizing components
- c. Increased usability
- d. Aesthetics
- e. Scalable
- f. Water Proofing
- g. Security

3.3 Mood Board

Smart and Futuristic

The mood board is depicted by derivatives of sleek form defined by their edge profiles. Characterized by incorporating streaks of light with textured and brushed metals to create a futuristic look.



3.4 Mind map

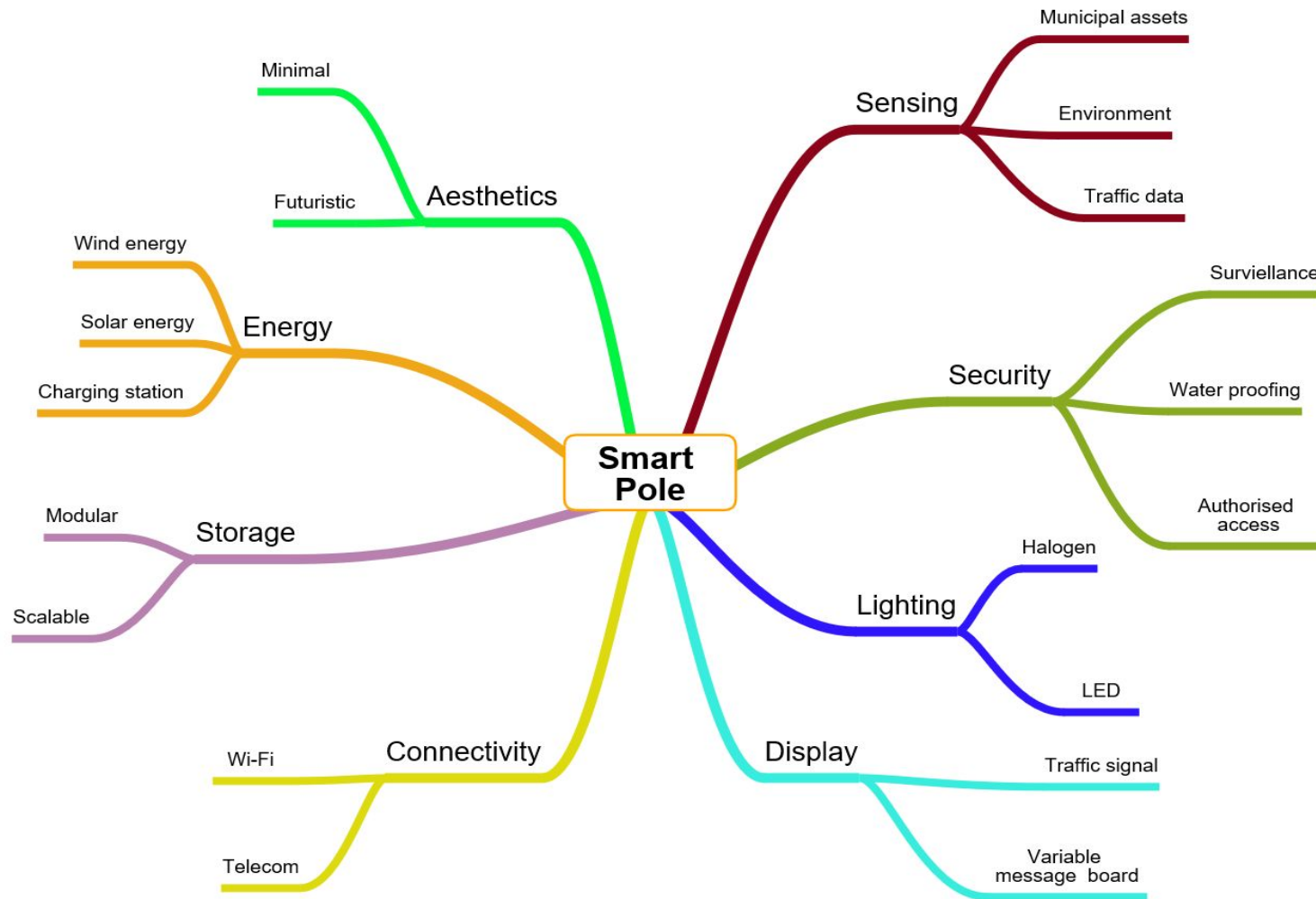

3.5 Product Autopsy



Mini cell tower



PTZ camera



Pole with flange plate



Ducting hose



Variable message display



VAWT

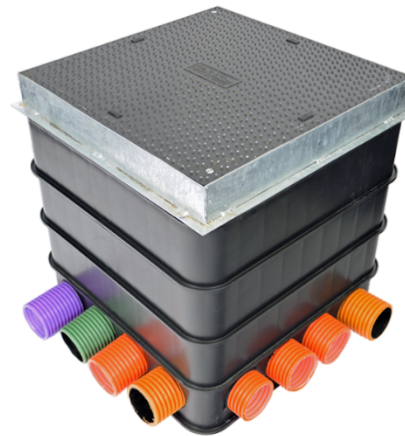

Access chamber



LED light head

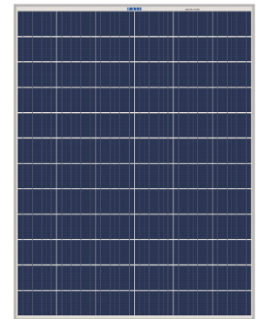

Solar panel

3.6 Volumetric data

Table 3.1 Volumetric data of components

| Sl.no | Name of the part | Dimensions L X B X H (cms) |
|-------|--------------------------|----------------------------|
| 1. | Surveillance camera | 15x15x20 cms |
| 2. | Signal head | 45X45X5 cms |
| 3. | Omni directional antenna | 30x30x15 cms |
| 4. | VAWT (wind turbine) | 40x40x60 cms |
| 5. | Storage box | 50x30x15 cms |
| 6. | Interface screen | 75x50x15 cms |
| 7. | Speakers | 20x20x20 cms |

3.7 Sketches

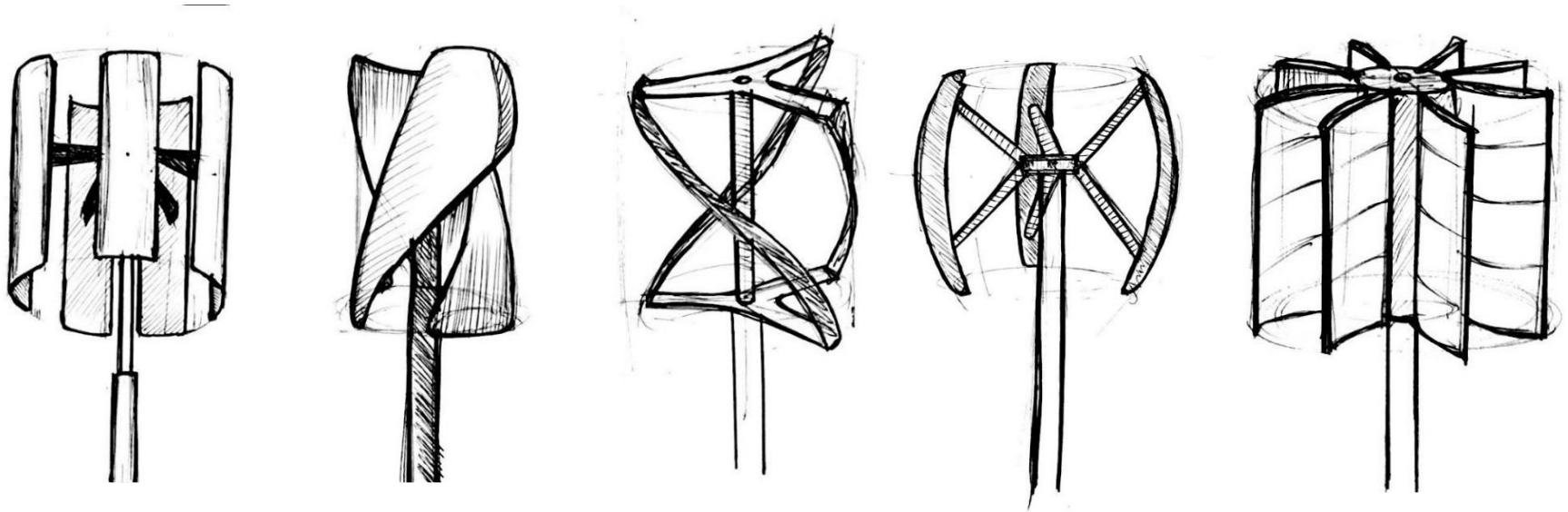

Vertical axis wind turbines

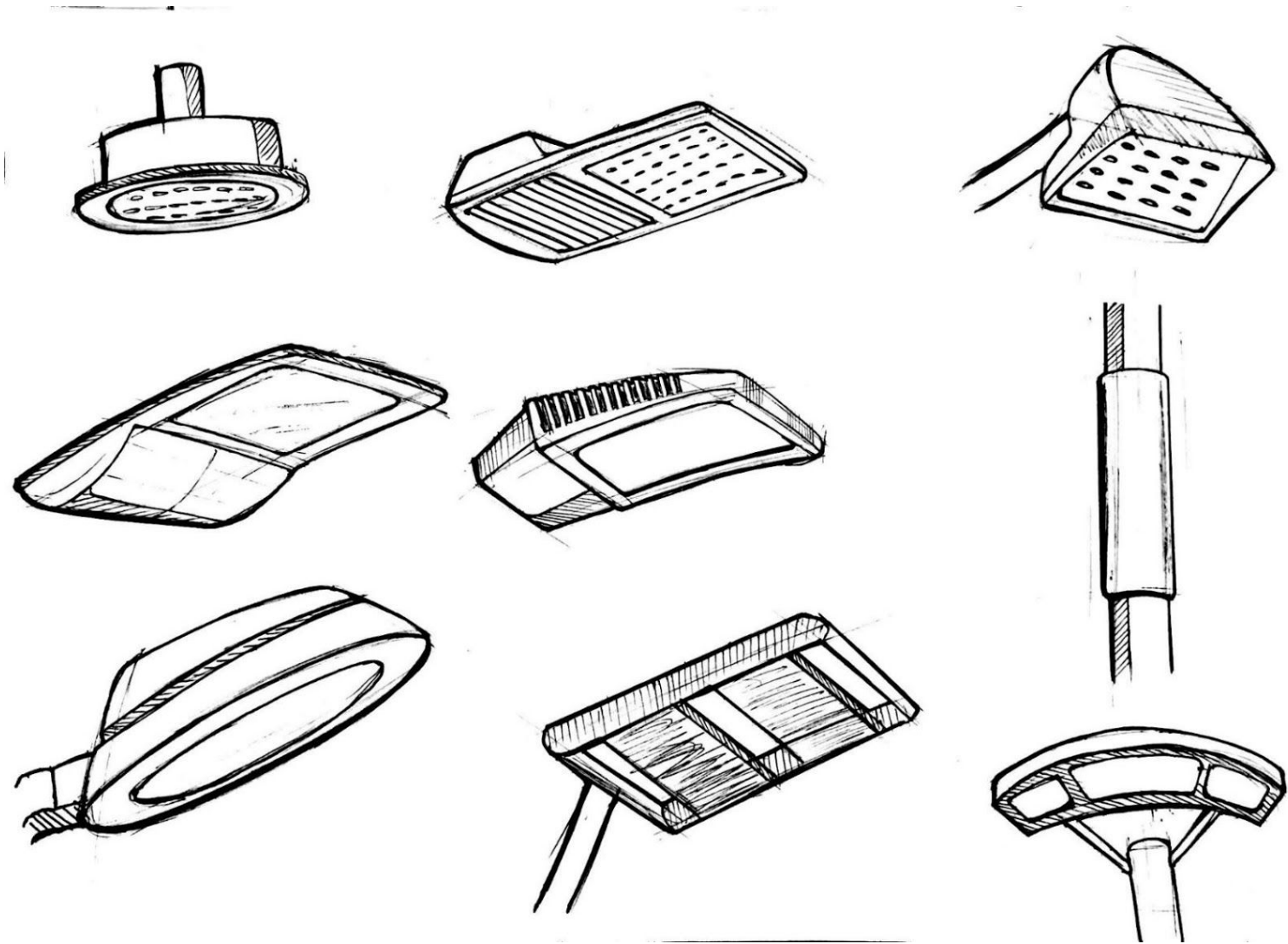

Light Heads

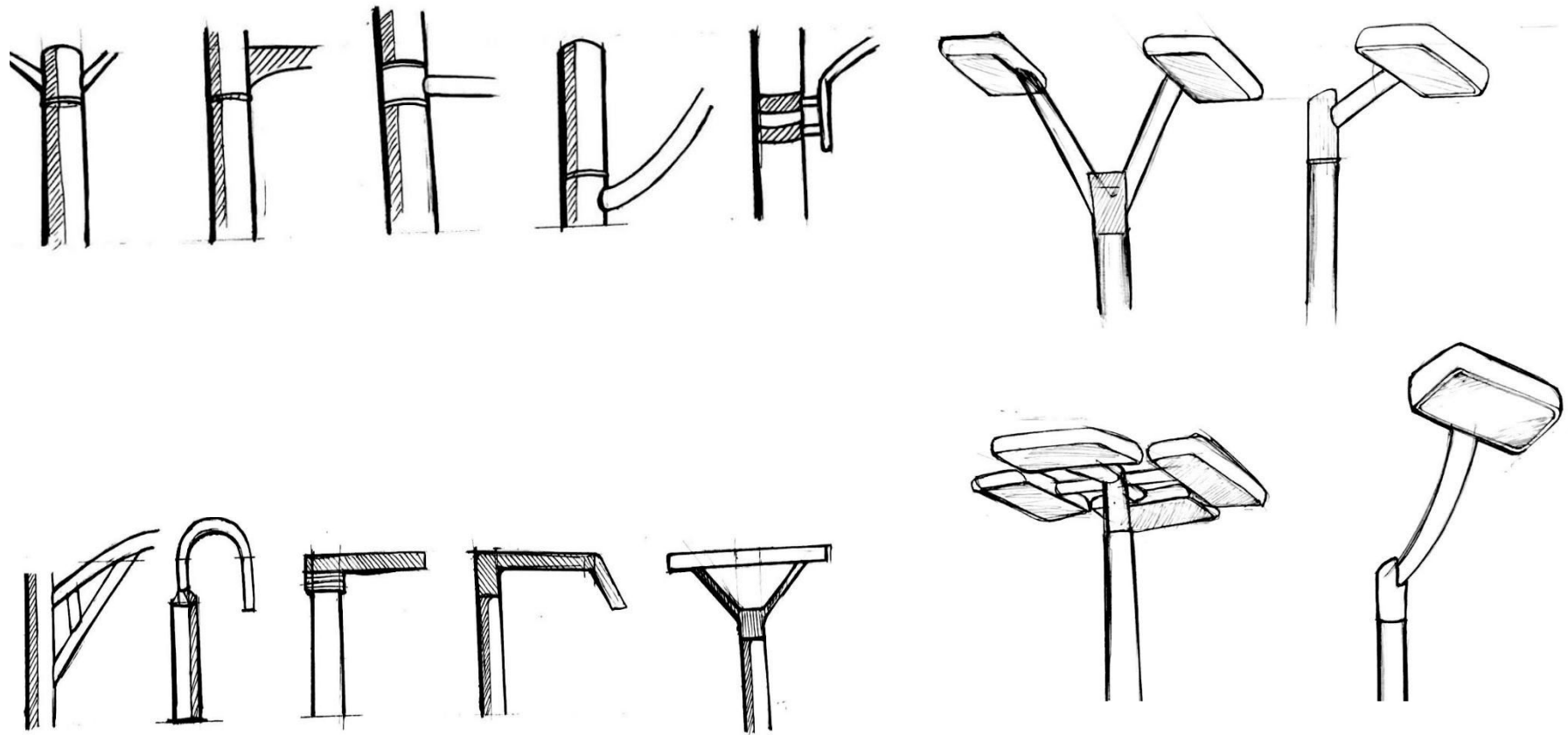

Light heads joinery

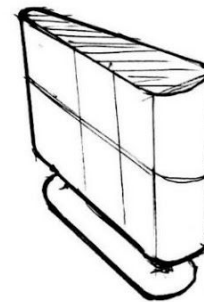
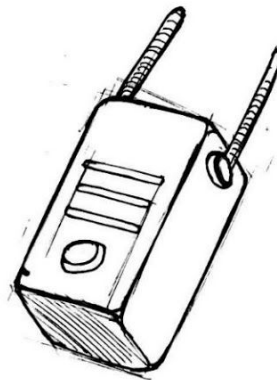
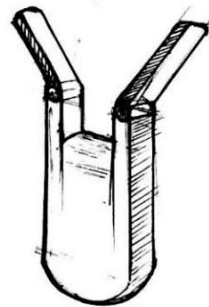
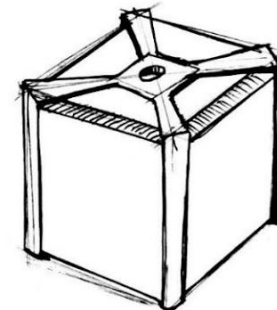
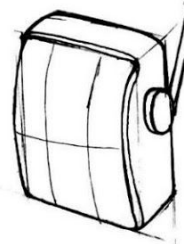
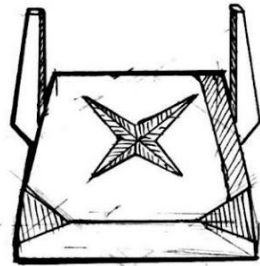
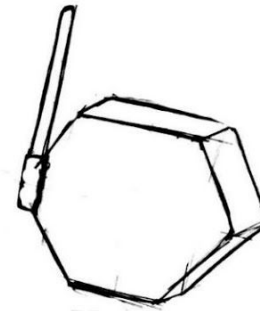
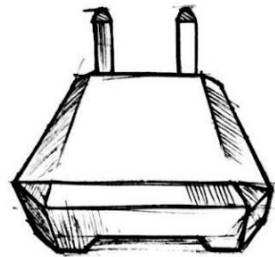

Mini cell towers

Light head variations

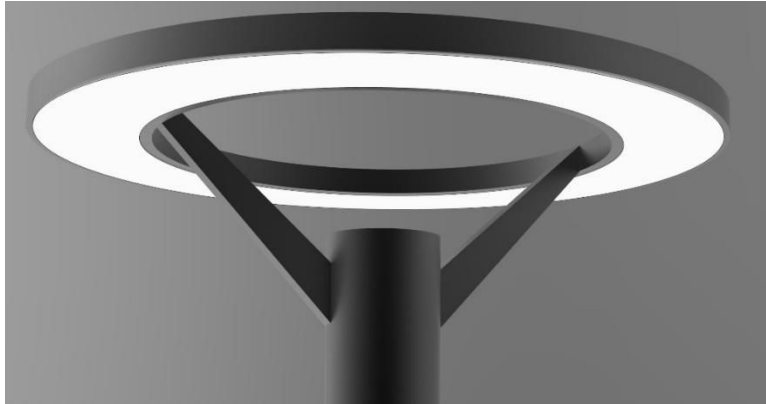

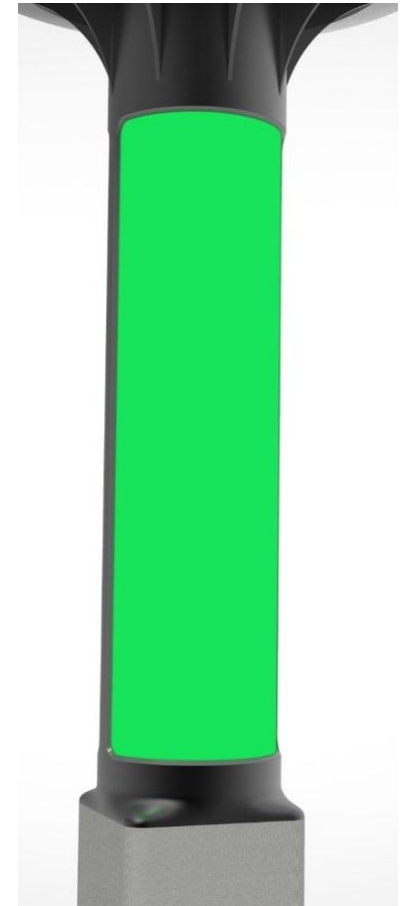

Signal head variations

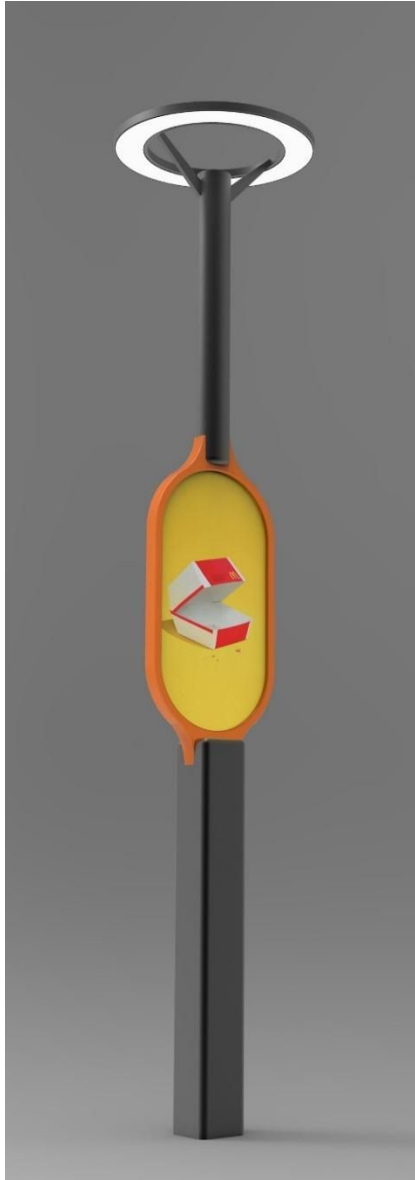

3.8 Concept generation

Concept 1

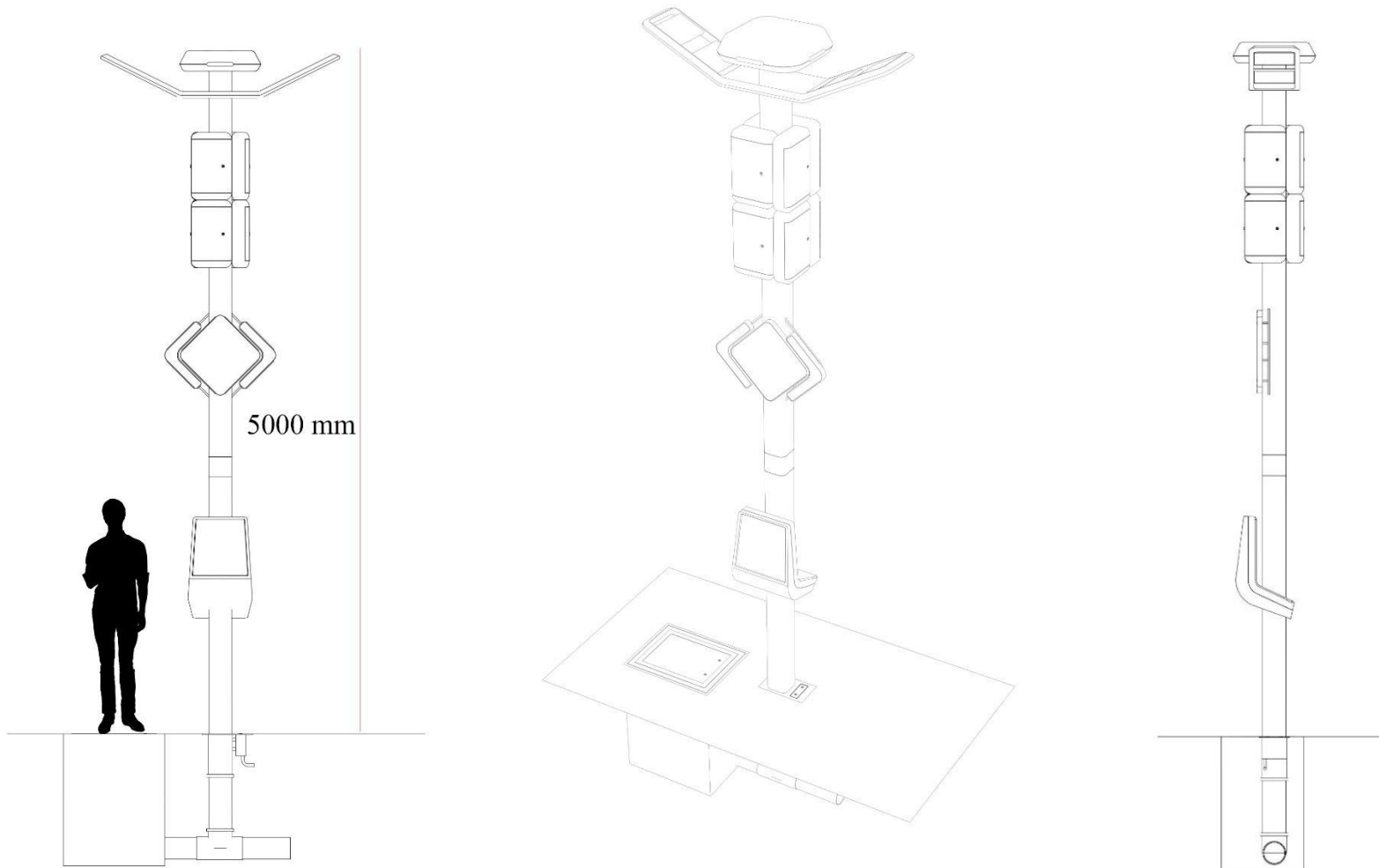

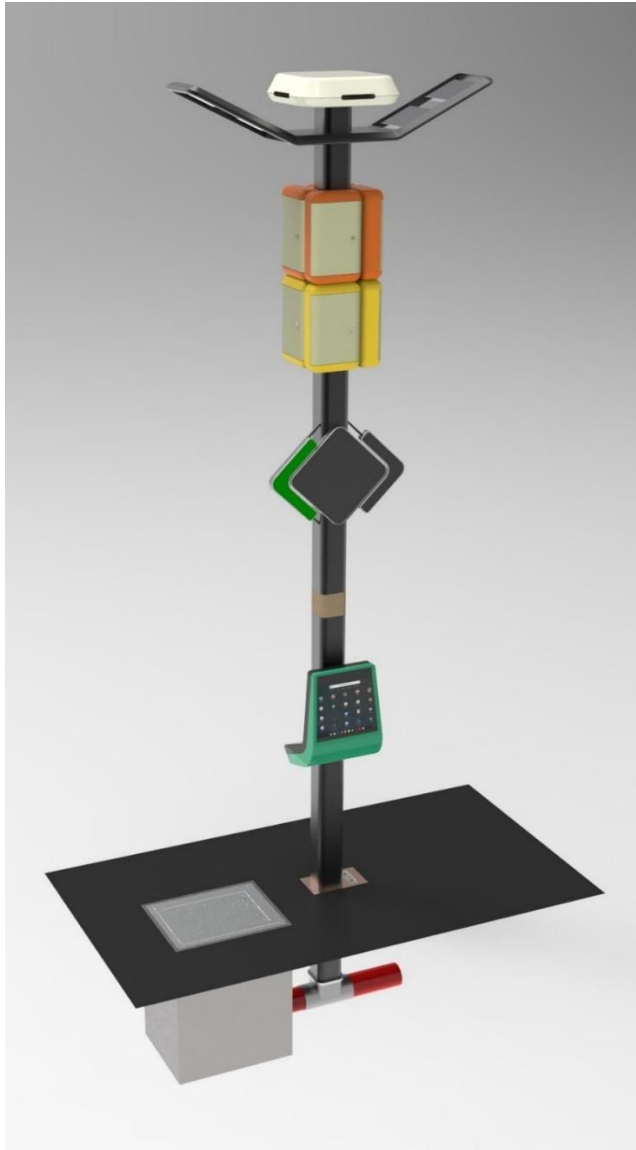

Mini cell tower



Public addressing speaker



Storage compartments



LED light head



Interface screen



Signal head

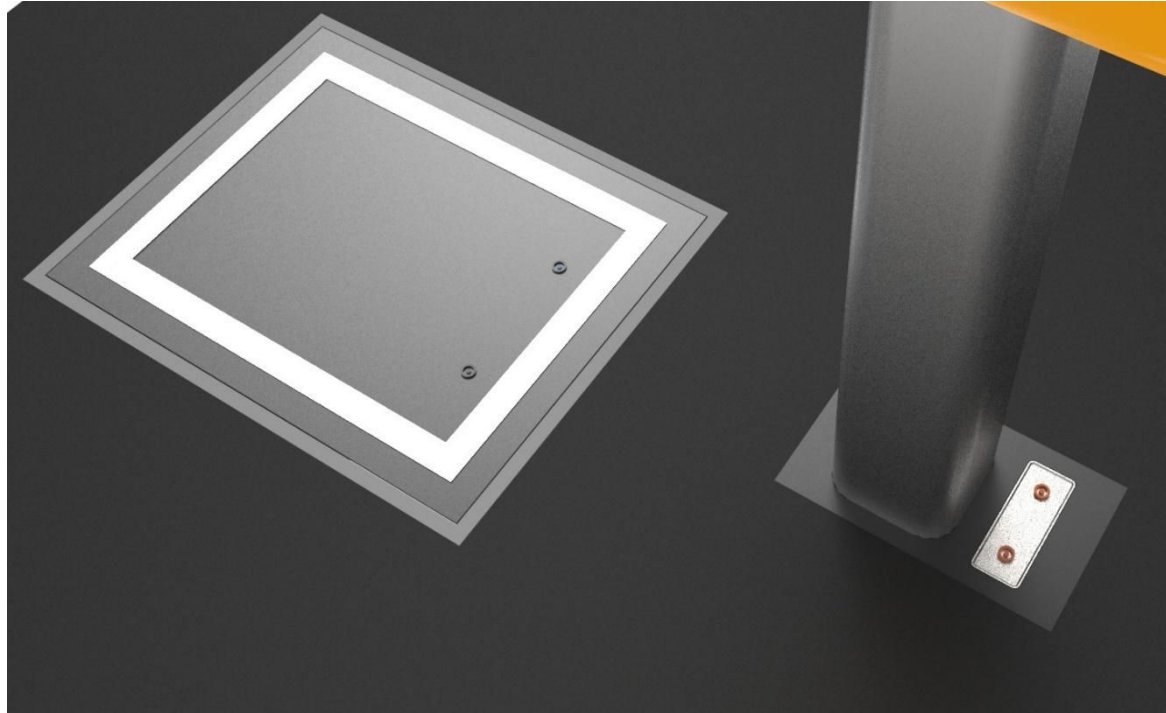

Ducting chamber

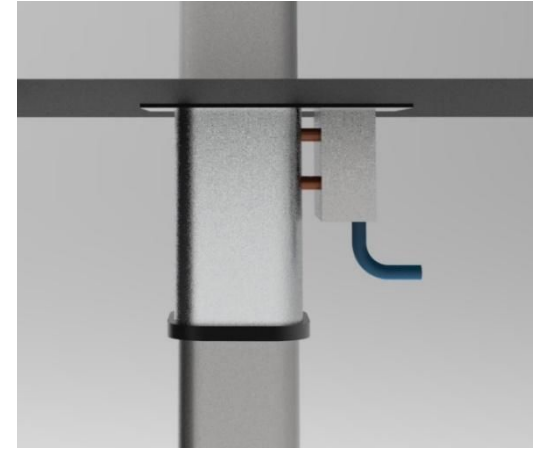

Retention socket

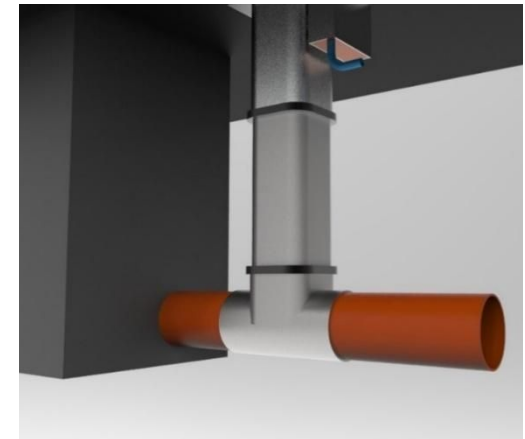

Ducting hose

Concept 2

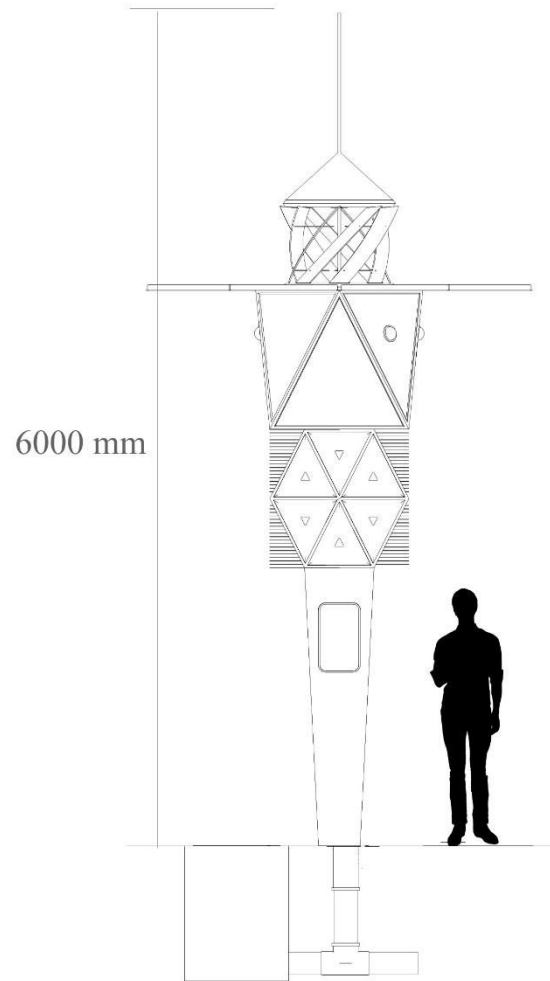



Solar Panels

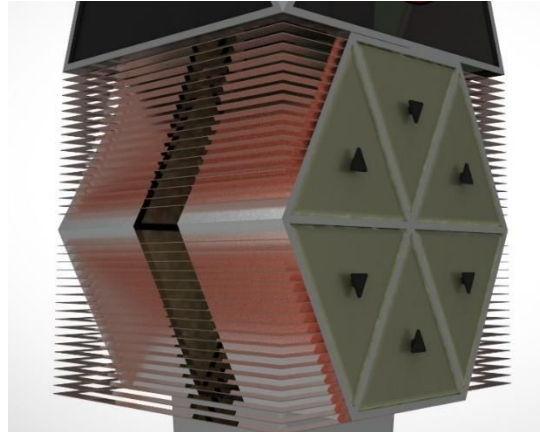

Modular storage



Interface screen



LED light panels



Display panels

Concept 3

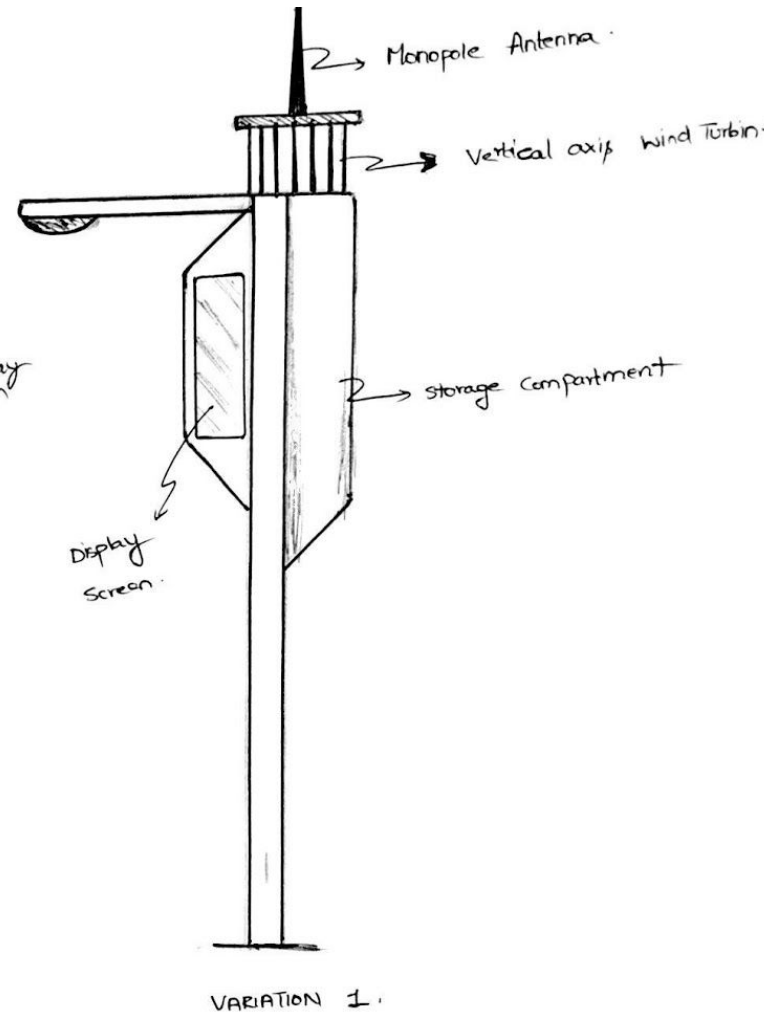
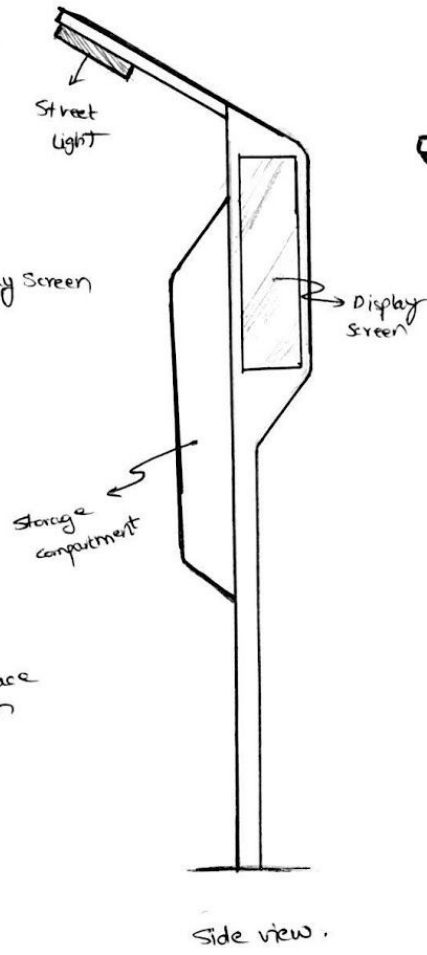
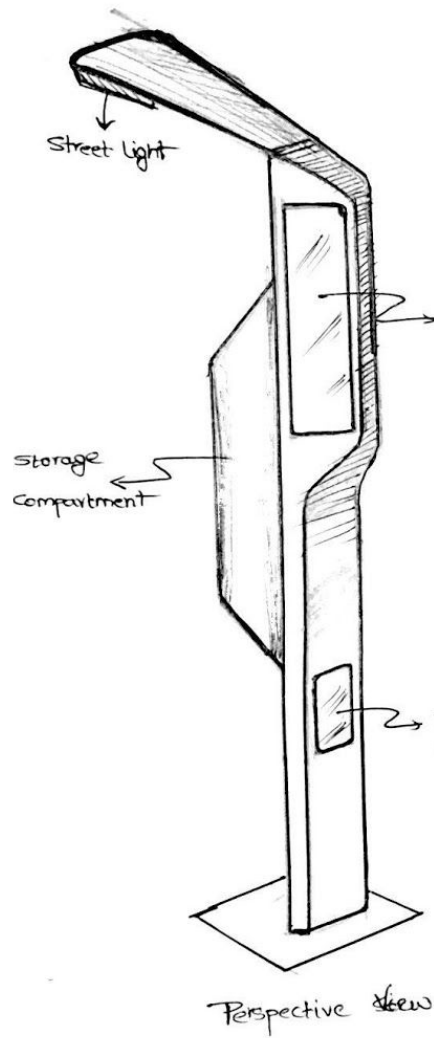

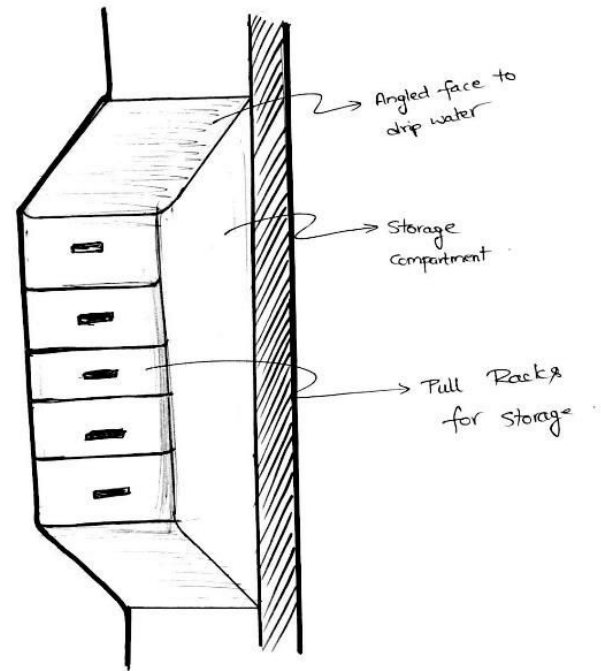
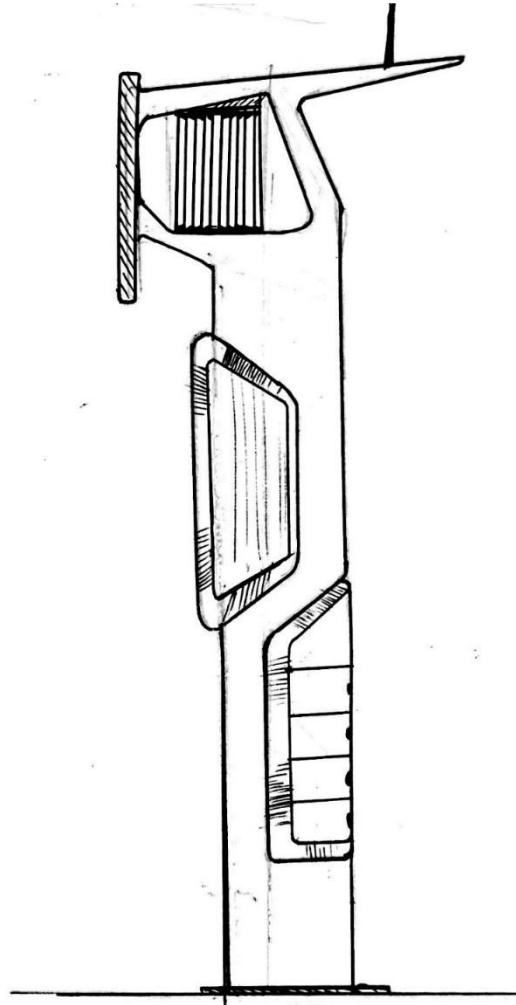
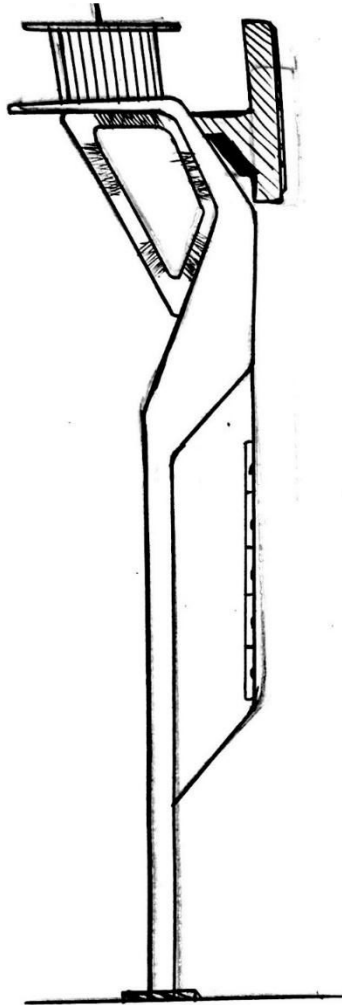

3.9 Final design



....An intelligent pole

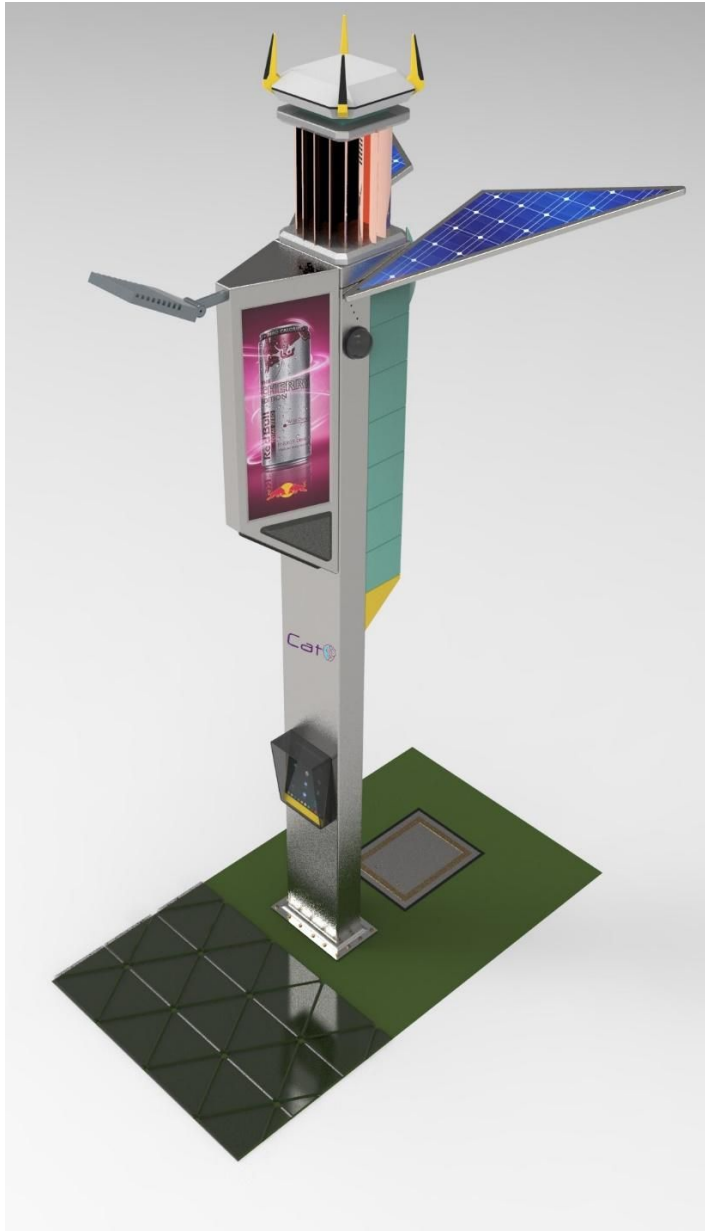

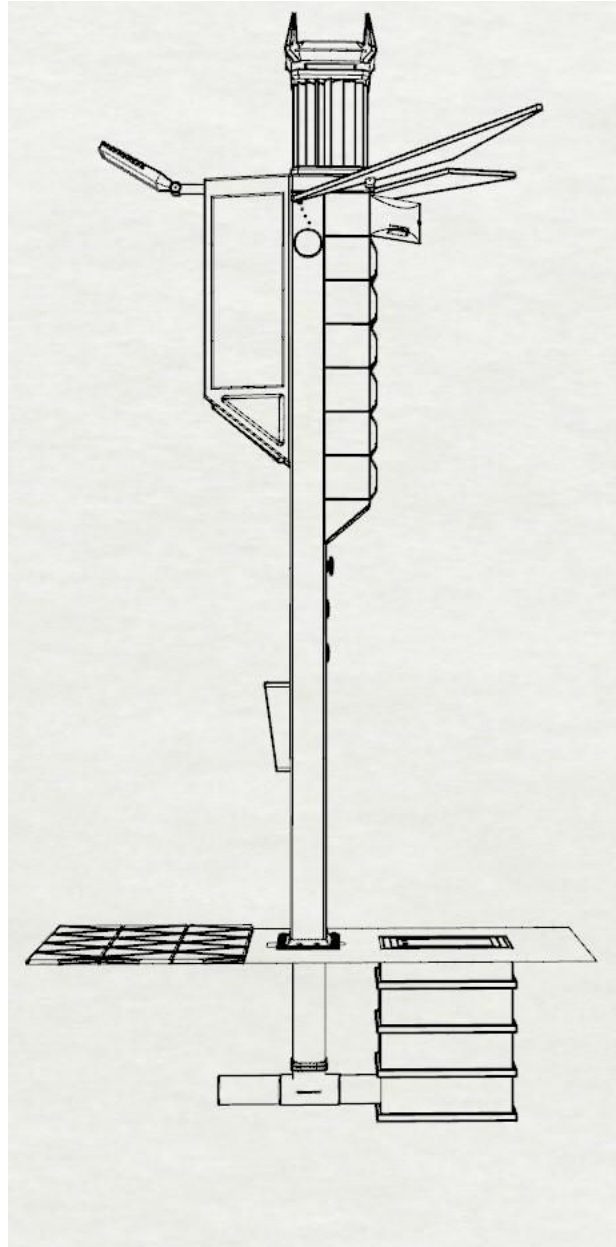
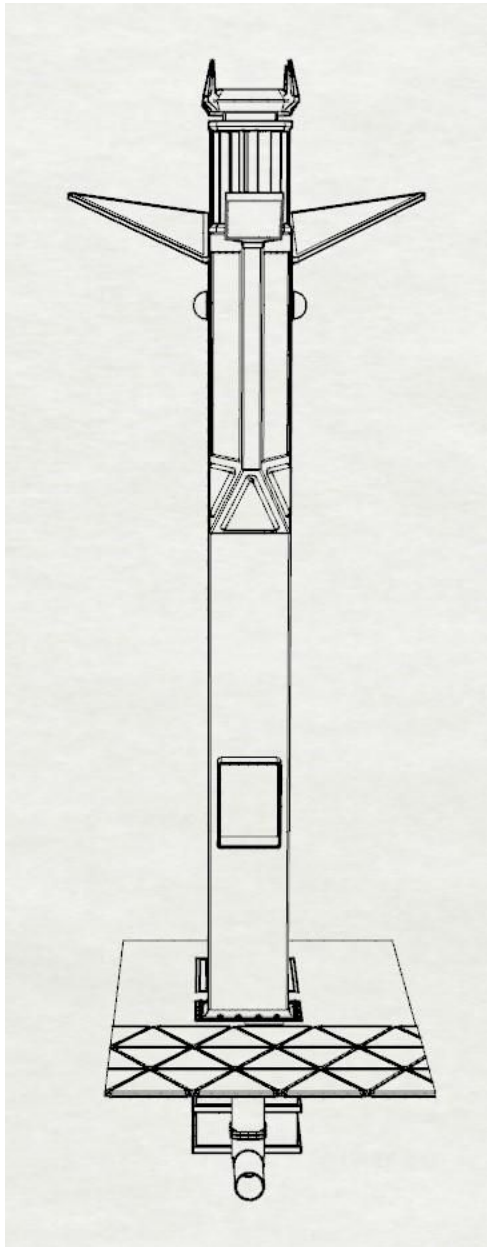

550 cms

Components of smart pole

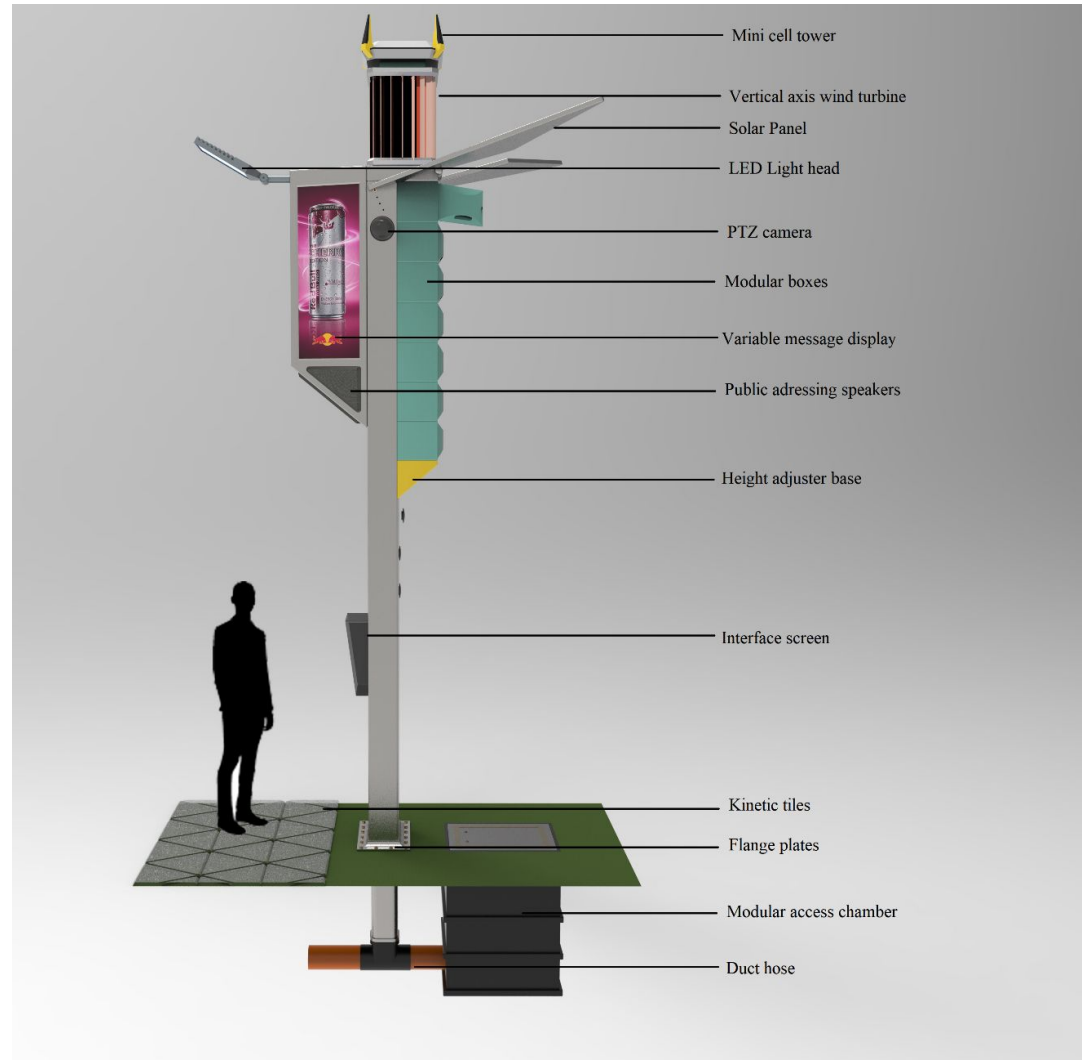

Detailed views of components



**Modular compartment
with single screw
fastening**

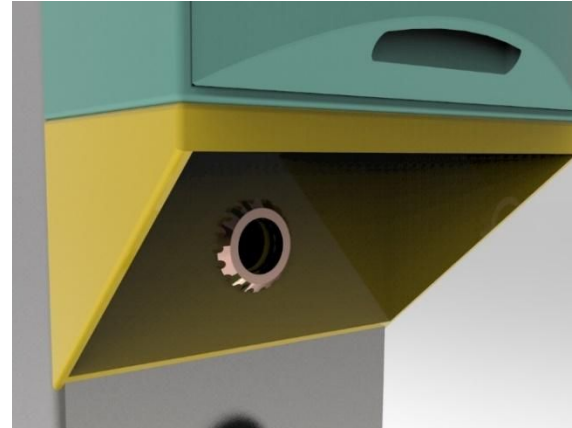

Adjustable holding base



**Lockable compartment
door with washer**



Covering for screw holes



LED light head

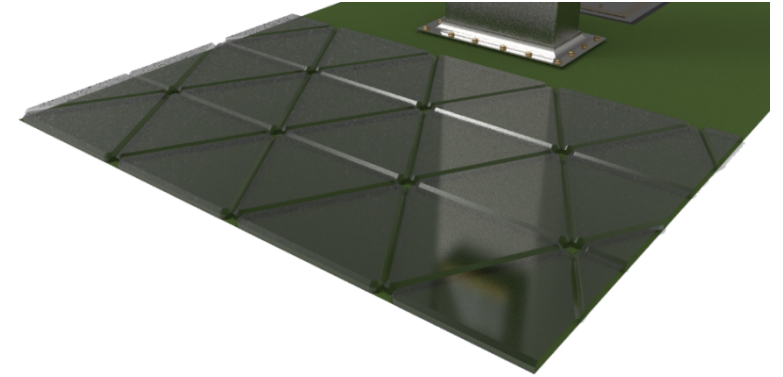
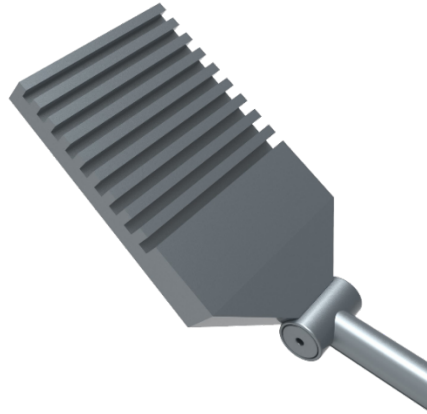

Kinetic tiles



Interface screen



Ducting chamber



Ducting hose



Ducting chamber cover

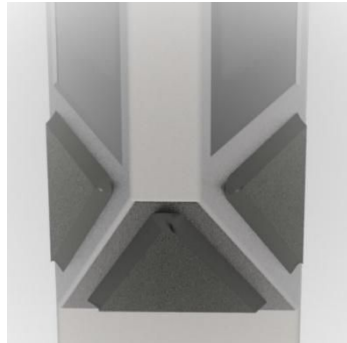

Public addressing speakers

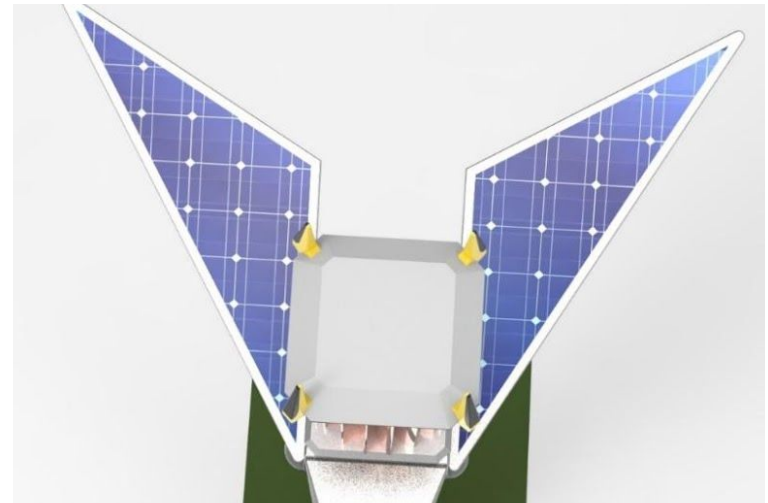

Solar panels



Flange plate



Dome camera

Dimensional drawings

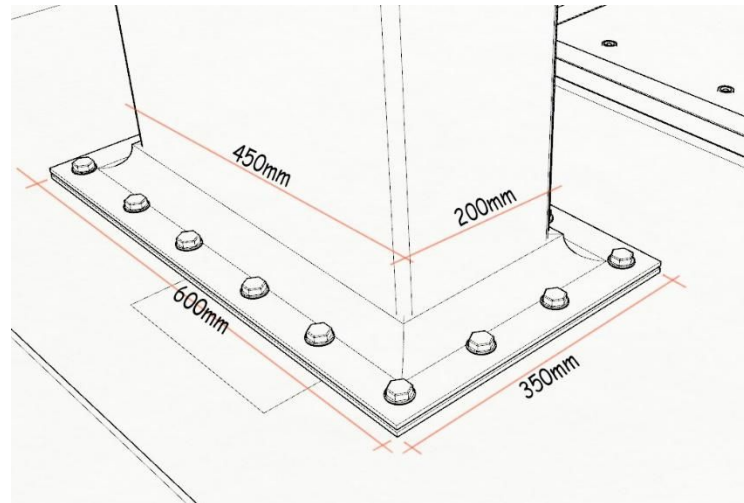
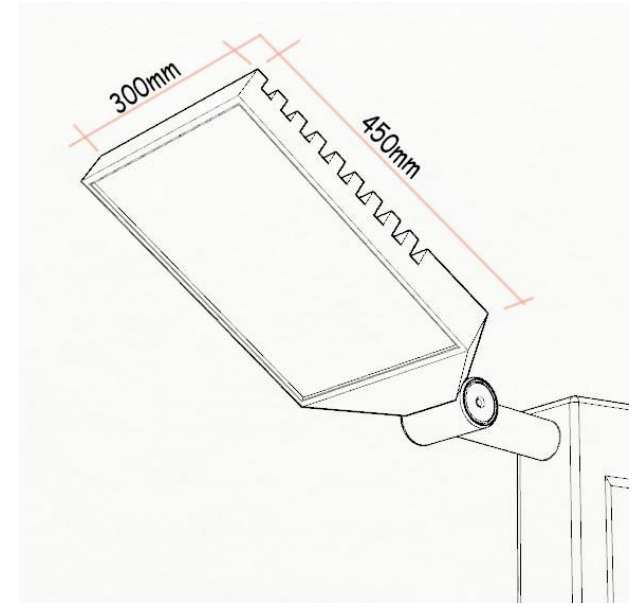
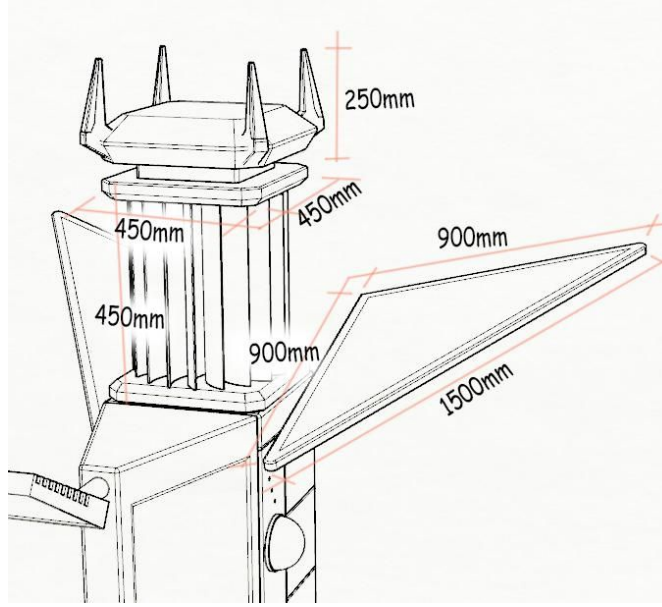
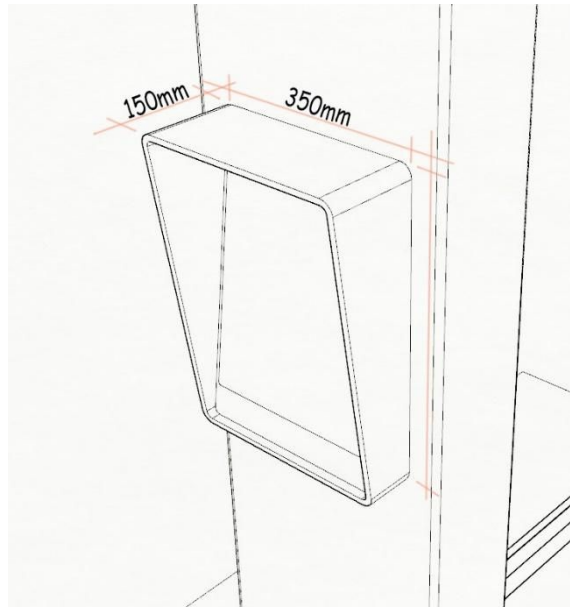

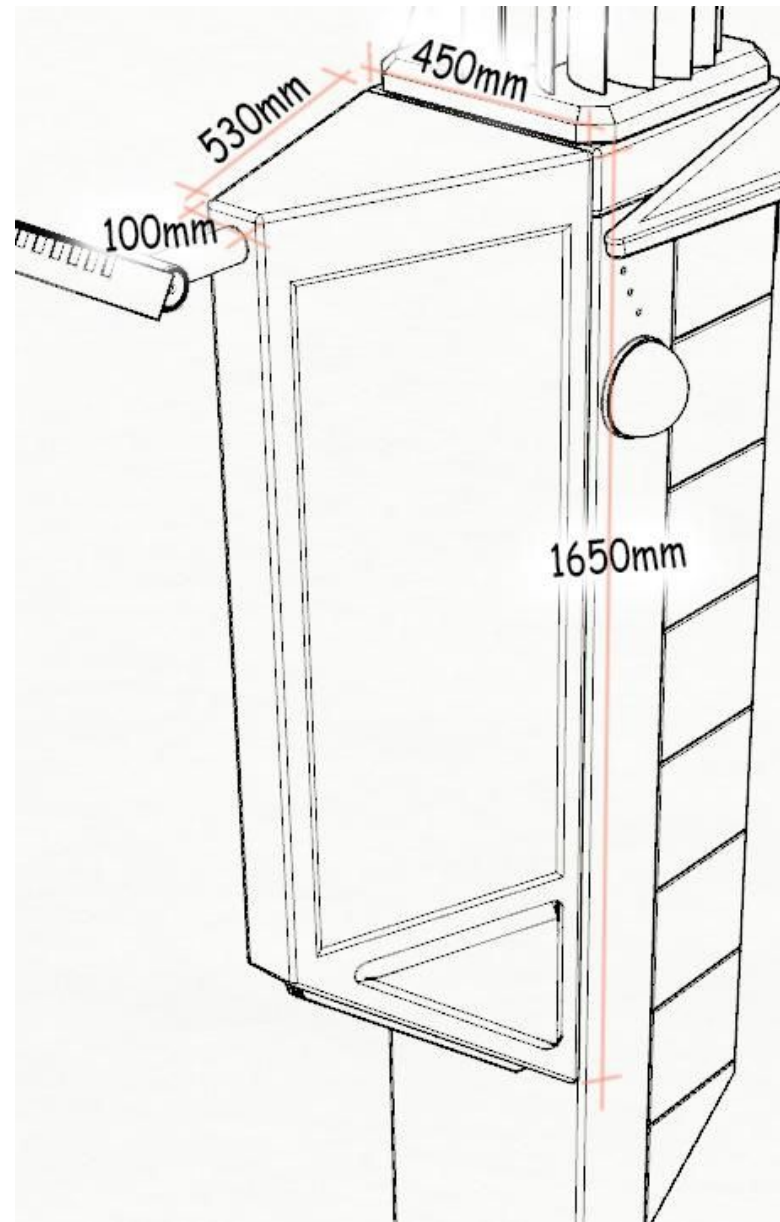
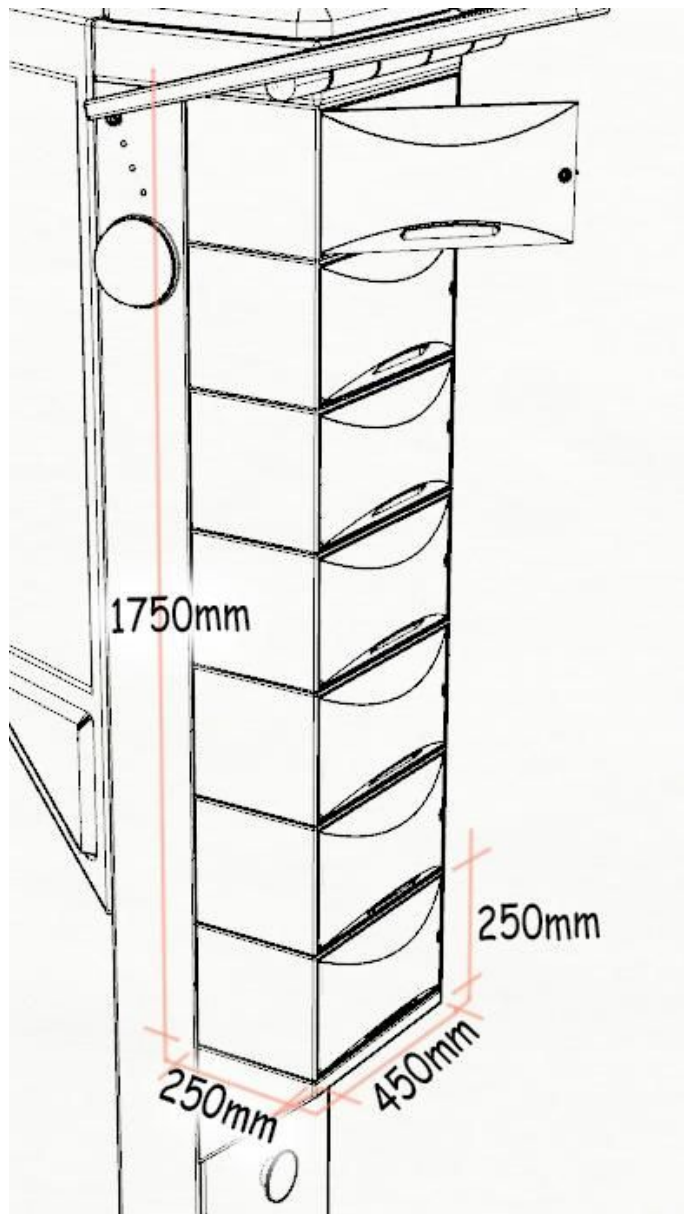



Placement of poles on roads

3.10 Branding and customization

Name: Cato is a Latin name meaning *Intelligent*. It's a four letter catchy word and is unique.

Logo:



Customization options:

1. The modular boxes on the pole are made of ABS, giving the customer a wide range of colors to choose from.

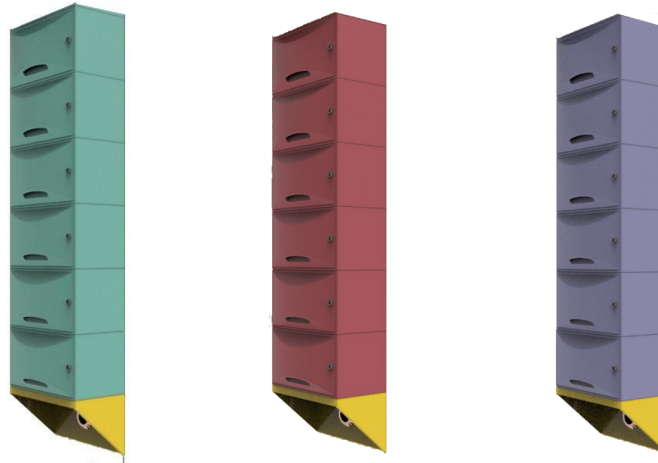

2. Pole can be vinyl wrapped based on client preference



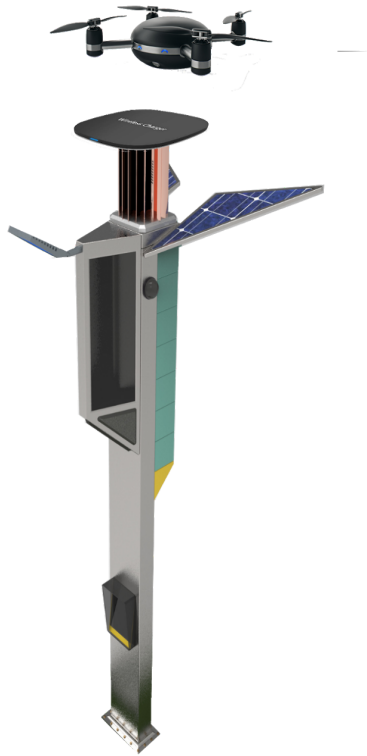

Drone charger



Electric Vehicle charger

3.11 Prototypes

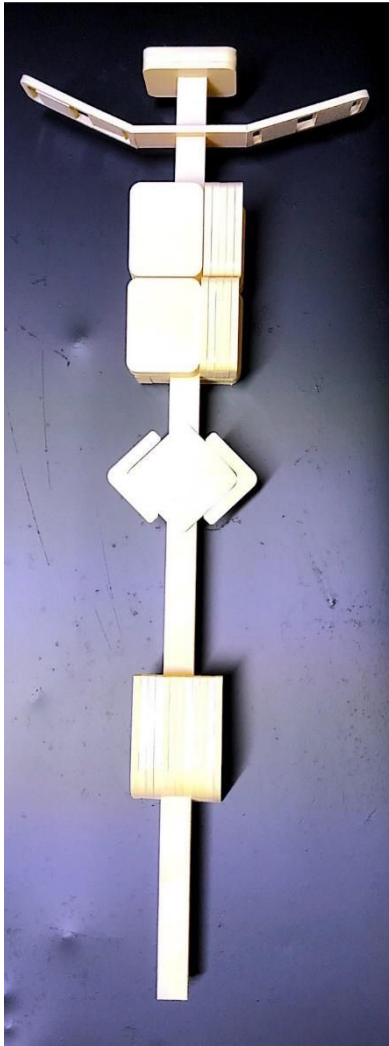

**Form model
for
Concept 1**



**Form model
for
Concept 2**

Form model for Final Concept



3.12 Materials and manufacturing

| Sl.no | Name of the part | Material | Manufacturing process | Remarks |
|-------|------------------|-----------------------|--------------------------------|---|
| 1. | Pole | Steel | Extrusion | Light weight and Durability (6 meter pole weighs 20 kg) |
| 2. | Pole finishing | Acrylic poly siloxane | Spraying | Inert and nonflammable |
| 3. | Ducting chamber | Polypropylene | Injection molded | High stiffness |
| 4. | Spiral duct hose | Poly vinyl chloride | Extrusion, winding and joining | Good tensile strength |
| 5. | Brackets | Galvanized steel | Stamping | Strength |

3.13 Pole placement

1. Poles are setup 500 meters apart to ensure enough “Handoff”, better connectivity in dense urban environment.
2. It's better to have more number of macro cell sites with lesser transmitted power so as to reduce radiations.
3. Pole planting depth 60 cms; Pole width 45 cms; Pole depth 20 cms; Pole wall thickness 0.8 cms

References

1. <https://www.india.gov.in/spotlight/smart-cities-mission-step-towards-smart-india>
2. https://en.wikipedia.org/wiki/Indian_road_network
3. <http://bsl.lacity.org/smartcity.html/>
4. <https://www.caughtoncamera.net/news/different-types-of-cctv/>
5. <http://continentalpole.com/products/smart-city-poles>
6. https://en.wikipedia.org/wiki/Public_address_system
7. <http://continentalpole.com/products/smart-city-poles>
8. <https://en.wikipedia.org/wiki/Sensor>
9. <http://www.alselectro.com/37-in-1-sensor-kit.html>
10. <https://www.nal.ltd.uk/product/stakkabox-access-chambers/>
11. https://www.siemens.co.uk/traffic/pool/handbooks/road_signals
12. <https://new.siemens.com/global/en/products/mobility/road-solutions.html>
13. <http://mohua.gov.in/>
14. https://en.wikipedia.org/wiki/Vertical_axis_wind_turbine
15. https://en.wikipedia.org/wiki/Solar_panel
16. <https://new.siemens.com/global/en/products/mobility/road-solutions/trafficmanagement/on-the-road/signalheads.html>

17. <http://www.lighting.philips.com/main/inspiration/smart-cities/smart-cities-initiative/smart-pole>
18. <http://www.obamaenergy.com/>
19. <http://energasia.in/>
20. <http://www.lighting.philips.com/main/inspiration/smart-cities/smart-cities-initiative/smart-pole>
21. <https://iotuk.org.uk/wp-content/uploads/2017/04/The-Future-of-Street-Lighting.pdf>

Figure 1.1 <http://arrahsetia.blogspot.com/2015/10/arrah-maps-history.html>

Figure 1.2 <http://continentalpole.com/products/smart-city-poles>

Figure 2.1 <https://www.att.com/att/microcell/>

Figure 2.2 https://en.wikipedia.org/wiki/Vertical_axis_wind_turbine#/media/File:BR_T01.jpg

Figure 2.3 https://en.wikipedia.org/wiki/Photovoltaic_system#/media/File:From_a_solar_cell_to_a_PV_system.svg

Figure 2.4 <http://www.androidcooltricks.com/led-lamp/>

Figure 2.5 https://www.signal-tech.com/products/parking/vms_series_smart_sign_rebel_display

Figure 2.6 <http://htldisplay.com/news/Industry%20News/114.html>

Figure 2.7 <http://www.sprocctv.com/>

Figure 2.8

[https://en.wikipedia.org/wiki/Public_address_system#/media/File:US_Navy_091222-N-2564M-106_Rear_Adm._Michelle_Howard_commends_the_crew_of_USS_Wasp_\(LHD_1\)_during_ship%27s_return_to_Norfolk.jpg](https://en.wikipedia.org/wiki/Public_address_system#/media/File:US_Navy_091222-N-2564M-106_Rear_Adm._Michelle_Howard_commends_the_crew_of_USS_Wasp_(LHD_1)_during_ship%27s_return_to_Norfolk.jpg)

Figure 2.9 <https://en.wikipedia.org/wiki/Touchscreen>

Figure 2.10 <http://www.alselectro.com/37-in-1-sensor-kit.html>

Figure 2.11 <https://www.nal.ltd.uk/product/stakkabox-access-chambers/>

Figure 2.12 <http://www.obamaenergy.com/smart-pole/>

Figure 2.13 <http://christendtimeministries.com/philips-lighting-american-tower-develop-4g-5g-extending-smart-pole>

Figure 2.14 <http://energasia.in/smart-poles/>

Table 1.1 https://en.wikipedia.org/wiki/Indian_road_network