



COOKING APPLICATION USING STEAM FROM SOLAR STEAM GENERATOR (RICE COOKING VESSEL)

M.Des Industrial Design Project III

SAIJITH M S
176130007

Guided by : Prof. B K Chakravarthy



Main renewable sources of energy

Solar energy is a clean and abundant source of energy. This energy is utilized for many applications and cooking is one of them.

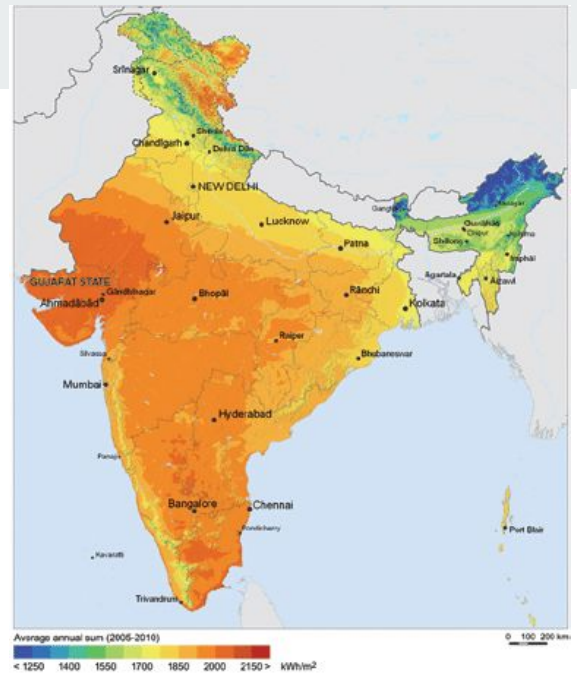

With about **300 clear, sunny days in a year**, India's theoretically calculated solar energy incidence on its land area alone, is about **5,000 trillion kilowatt-hours (kWh) per year**. The solar energy available in a year exceeds the possible energy output of all fossil fuel energy reserves in India.



Simple and Affordable Steam Generator developed by Heat Pump Lab (Mechanical IITB)

Heat Pump lab at IIT Bombay has developed a steam generator which uses **evacuated glass tubes deployed with multi-wall polycarbonate top cover and multi layer rigid foam back insulation**

Storage medium **temperature of 200 to 300°C are achieved** with this design. Preliminary experimental data reveals that such collectors can be used to generate steam at 1 to 10 bar using the low cost seasonally tracked low profile collectors.

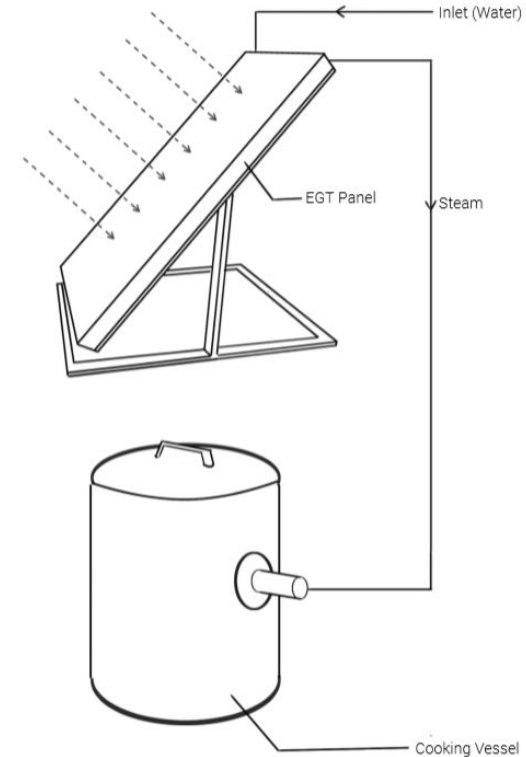



The inner glass tubes are filled with heat storage medium to store the collected heat

A copper tube coil with aluminium foil fin is deployed in the storage medium to enable extraction of heat as and when needed.

Heat loss from the bottom side is reduced using a multilayer rigid foam insulation under the EGT and reflectors.

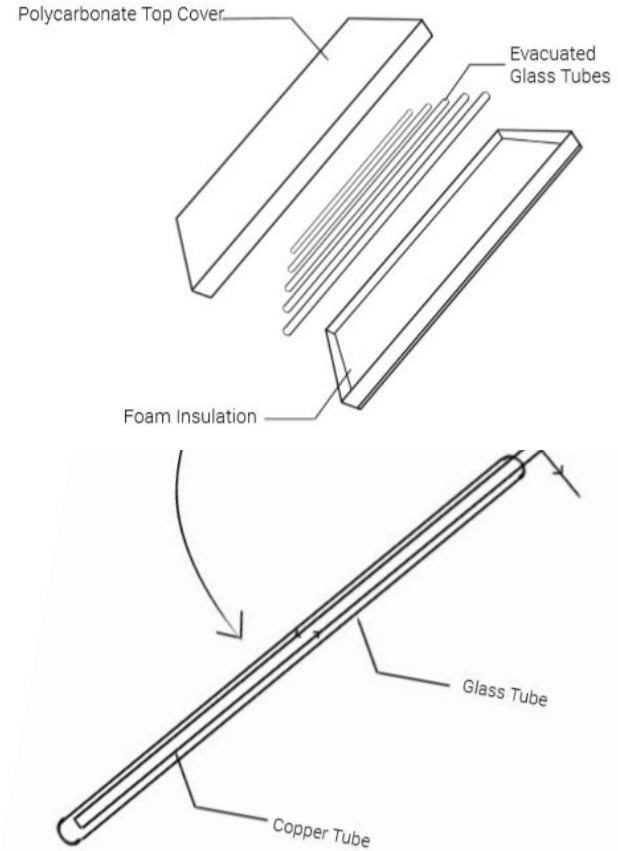



Area of exploration.

Implementation of this technology in places where food is cooked in huge quantities (hotels, hostels, hospitals etc) so that a lot of other sources (fossil fuel, LPG) of energy can be saved.

Data Collection

Data collection has been done to understand about the technology involved and to gain an overall idea about the existing trend and products that is prevailing in the market.



Advantages Of Steam Cooking System.

- Steam Cooking **retains the texture & shape** of the cooked food
- The Food **won't get over cooked.**
- In conventional cooking system 4 Burners used for Cooking 4 Items, whereas in Innovative Steam Cooking System **1 Burner cooked 4 Item at a time** Saving of Time & Fuel
- This cooking system require **less time for cooking**



Advantages Of Steam Cooking System.

- **Cost effective** as compare to any another cooking system.
- **Energy cost saving approximate from 40% to 60%** as compared with traditional cooking system.
E.g. If your annual energy cost is Rs. 3,00,000/- then after use of our cooking system your organization will save Rs. 1,20,000/- to 1,80,000/- every year.
- **Meal preparation time saving is approximate from 35% to 50%** as compared with traditional cooking system.
- Kitchen remains much cleaner because of **less smoke produced**.



Steam Boiler

- Electric steam boiler
- LPG steam boiler
- Fire wood steam boiler
- Solar Steam boiler



LPG steam boiler



Electric steam boiler



Fire wood steam boiler

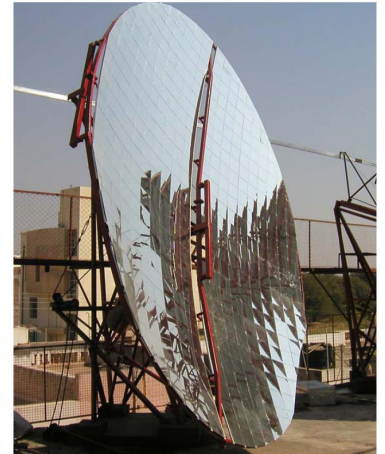

Solar steam boiler



Steam Vessels

There are various kinds of steam vessels available in the market, which are used in chemical industry, cooking industry etc.





Steam Jacketed Cooker

Approx. Rs 65,000 / Unit
Material : Stainless Steel
Material Grade : SS 304, SS 316 L
Capacity : 150 Litre and above



Non Jacketed Steam Cooking System

Approx. Rs 2.5 Lakh / Unit
Material : Stainless Steel
Material Grade : SS 304
Capacity : 150 Litre and above



Jacketed Steam Cooking System

Approx. Rs 1,00,000 / Unit
Material : Stainless Steel
Material Grade : SS 304, SS 316 L
Capacity : 150 Litre and above



Sealed Kettles

Approx. Rs 1,20,000 / Unit
Material : Stainless Steel
Material Grade : SS 304
Capacity : 100 Litre to 1500L



Steam Kettle With Stirrer

Approx. Rs 1,00,000 / Unit
Material : Stainless Steel
Material Grade : SS 316
Capacity : 100 Litre to 800L



Steam idli cooking device

Approx. Rs 10,000 / Unit
Material : Stainless Steel
Material Grade : SS 304
Capacity : 60,120,180 upto 360 idlies per cycle



Tilting Steam Boiling Pans

Material : Stainless Steel
Material Grade : SS 316
Capacity : 150 litre and above
Type : Vertical



Steam jacketed vessel

Material :Stainless Steel
Material Grade : SS 316
Capacity : 150 liters & above.

Shirdi, Maharashtra, India

- The system **generates steam** for 20,000 pilgrims twice a day.
- The system comprises of **73 solar dishes**, each with an aperture area of 16 m²
- The system is also **connected to a conventional boiler**, which runs on **Liquefied Petroleum Gas (LPG)**, in case the weather turns out to be too cloudy.
- The installation is expected to **save around 100,000 kg of LPG per year**, which is equivalent to INR 2 million.



Tirumala Tirupati Devasthanam

- Tirumala Tirupati Devasthanam has the **world's largest solar steam cooking system** using the Scheffler Community Kitchen design.
- The system is comprised of **106 rooftop-mounted parabolic concentrators** that generate steam for cooking up to **30,000 meals daily**.
- It saves Tirupati **1.2 lakh litres of diesel every year**.
- The chefs say that it takes less than **20 minutes to cook an entire meal**.



Major manufacturers of steam cooking vessels



Suryansh Enterprise

<http://suryanshenterprise.com/>

Swaraj Industries

<https://www.swarajindustries.com/steam-cooking-system.html>

Scheffler Community Kitchen

http://solarcooking.wikia.com/wiki/Scheffler_Community_Kitchen

Cleveland

<https://www.clevelandrange.com/Products/Steam-Jacketed-Kettles/Floor-Models>

Berto's

<https://www.bertos.com/en/plus/tilting-boiling-pans/19-152.html>

User Study

Study has been conducted to understand about the cooking pattern in a community cooking spaces, to know more about the steam cooking, their pros and cons right from the users perspective.

Hostel 6

LPG steam boiler, rice cooking vessel, jacketed vessel, idli cooking device.

Cooking rice, Boiling water, sambar, dal etc idli were the main dishes prepared using boiler.



Hostel 12

LPG steam boiler, two rice cooking vessel, two idli cooking device

Cooking rice, Boiling water, idli are mainly cooked using the device.



Cooking Process



Steam boiler



Water inlet to vessel



Non-jacketed vessel



Rice transferring into the vessel

1. Water tap to the boiler is opened and ensured there is enough water pressure. Then the boiler is started.

2. Water is filled in the vessel to the required level.

3. Steam is passed into the vessel to get the water boiled. Lid is kept closed to attain the boiling point faster.

4. Washed rice is transferred into the vessel once the water gets completely boiled.



Stirring the food

5. Rice has been stirred and checked in between to make sure it is completely cooked.



Food getting cooked

6. Once completely cooked lid is removed and the steam inlet valve is closed.



Draining of waste water.

7. The drain valve at the bottom of the vessel is opened and excess water is drained out.



Transferring of food

8. The vessel is then tilted to transfer the cooked food from the cooking vessel.

Jacketed vessel

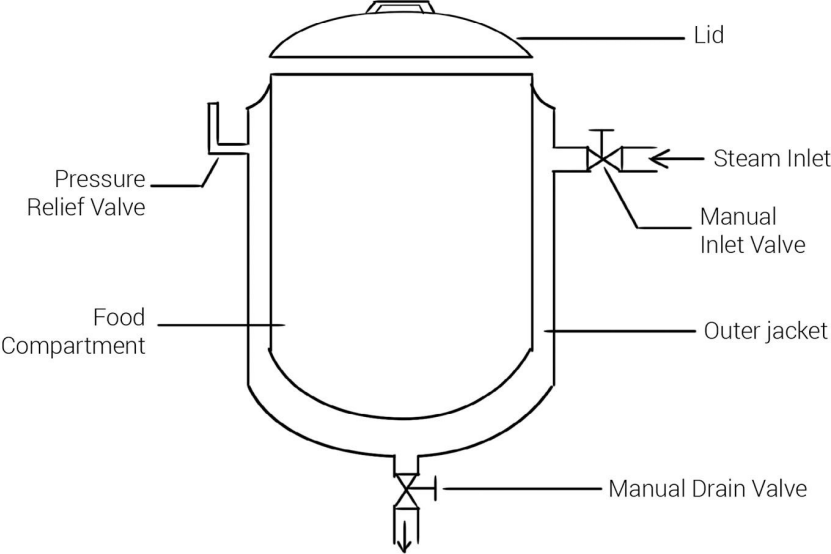
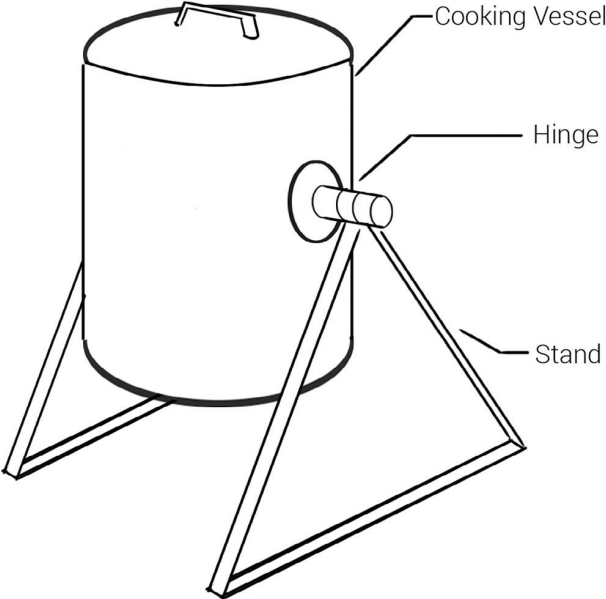

Heats most of the surface area which results in faster cooking.

Non Jacketed vessel

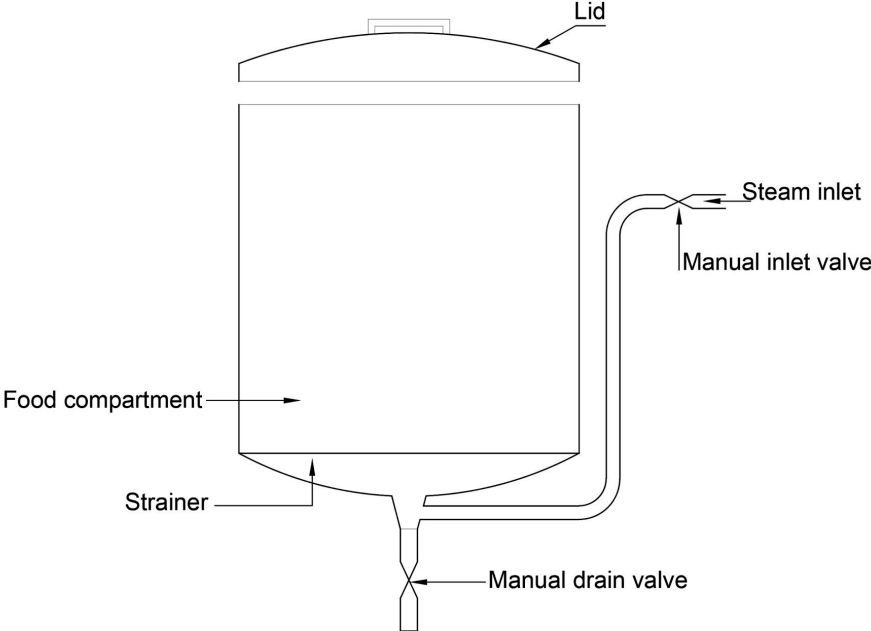
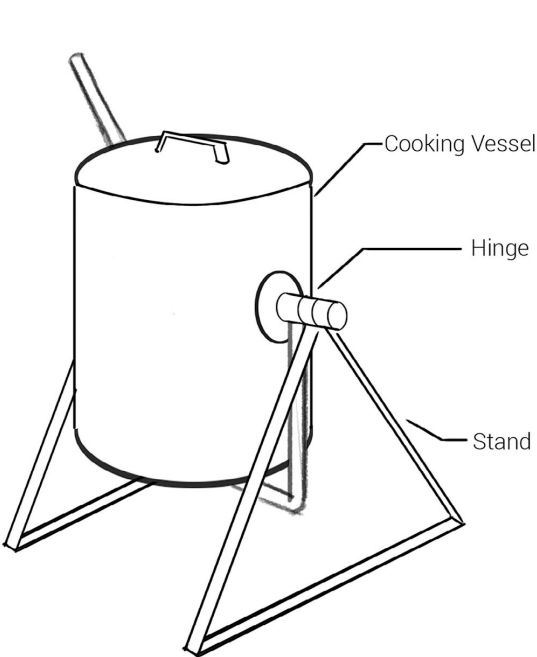

Idli cooking device

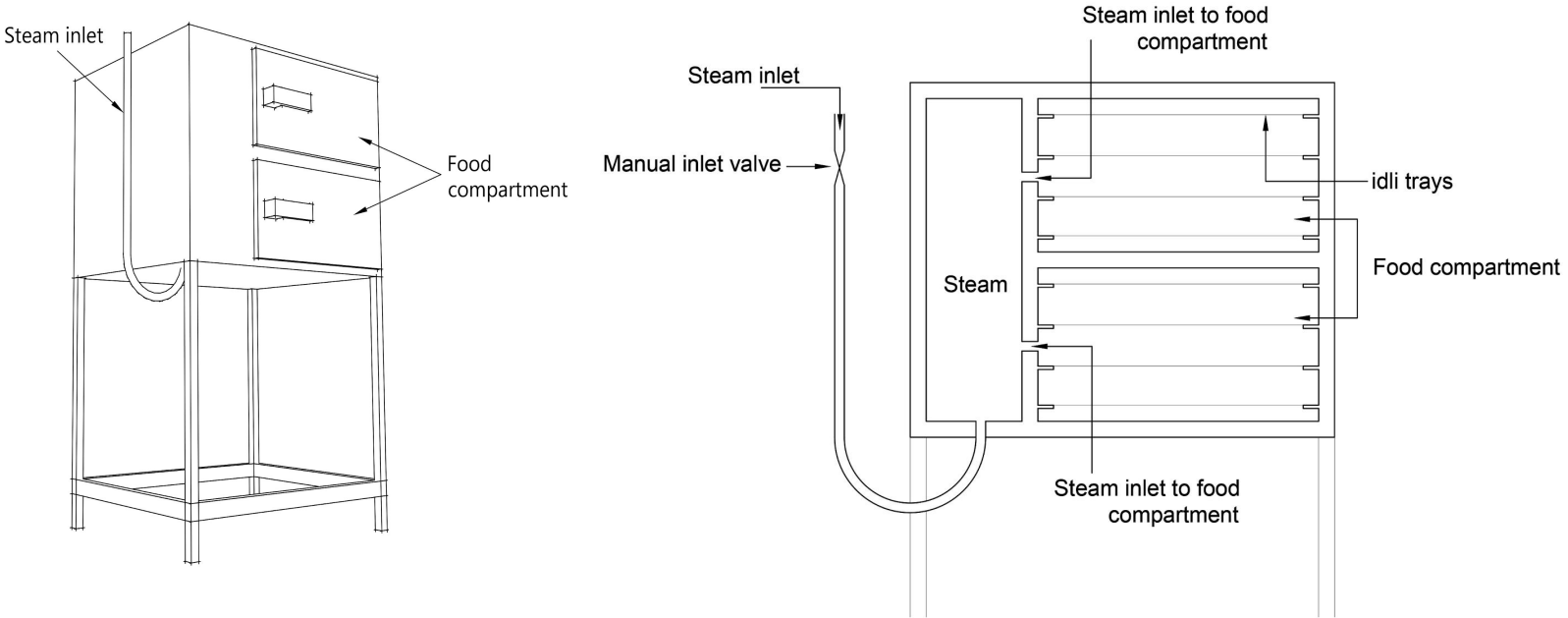

Observations



Fig38. Water connection to the vessel.

No proper water connection



Fig39. Using stirrer for cooking.

Difficulty in stirring because the vessel is always free from the hinge.



Fig40. Drain valve

The main drain valve and its tap are tightly designed.

Observations



Fig41. Lid of the vessel.

Difficulty in keeping the lid of the vessel.



Fig42. Steam valve of the vessel.

Tap of the steam is not at an approachable distance.



Fig43. Jacketed vessel

Cleaning of the vessel becomes difficult.

Observations



Fig44. Draining the waste water.

No proper drain for the waste water after cooking.



Fig45. Stirrer kept on top of the vessel.

No proper place to keep the stirrer.



Fig46. Transferring food

The handle design makes it difficult for the user in tilting the vessel.

Design Brief

To design a cooking device heated by steam which can perform rice cooking for 500 to 600 people in a community cooking environment (hostels, hospitals, canteens etc.).

Design Problem

The problem here is to come up with a user-centric design for a cooking system which is heated using steam from solar steam generator. The main intention is to make the whole cooking experience easy for the user. There are similar products in the market which are just intended to serve the purpose; but the idea here is to identify and solve the existing problems and come up with a new design.

Design Considerations

- Operation of the cooking system should **not be complicated**.
- **Food grade materials** should be chosen for main components in the system.
- Should **not have much maintenance** issues once it is installed.
- **Cleaning should be easy** since it is going to be in a mass cooking environment.
- **Functionality** is the major concern.
- **Modularity** will be an add on to the design.
- Care should be given for a **proper water inlet** for the device.
- **Locking system** for the vessel should be addressed.
- **Approachability to the drain valve** should be taken care of.
- **Drain water management** is a major concern, since the cooking environment should be always maintained clean.
- Packing, transportation and assembly should be considered in the design.

Ideation

Initially ideas were generated taking individual aspects that were found from the observations. Furthermore ideations were done combining one or more ideas that was initially done.

Different ways by which stirring can be done

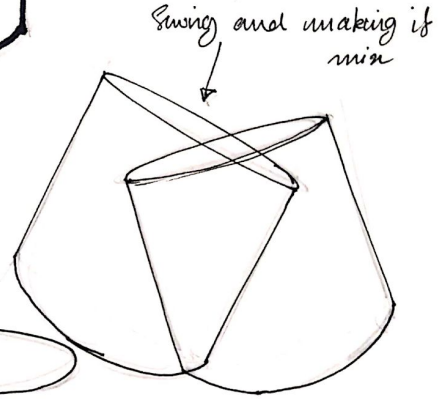
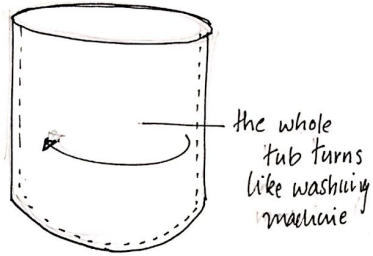
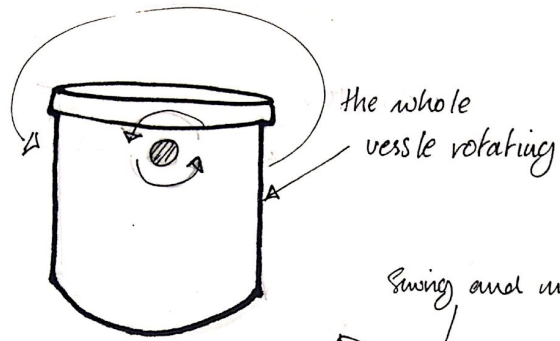
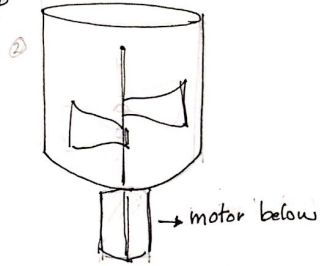
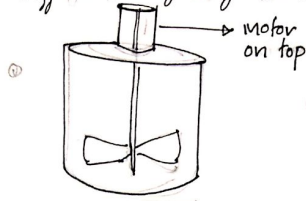

Manually rotating stirrer attached to the lid.

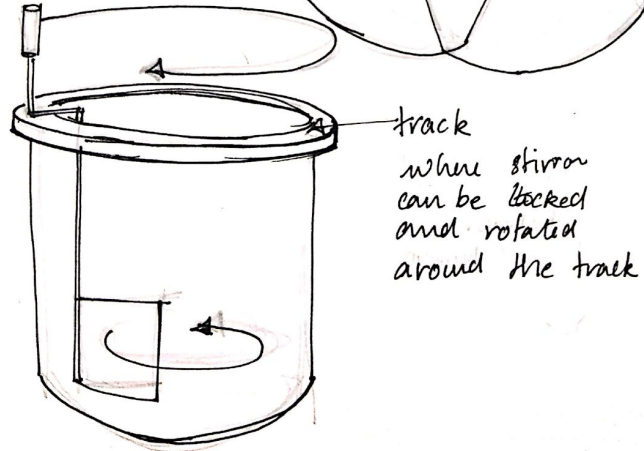
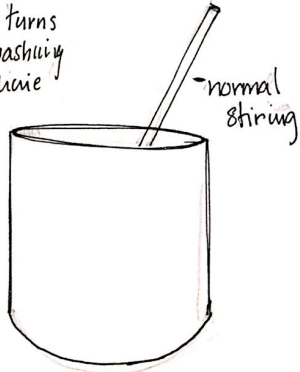
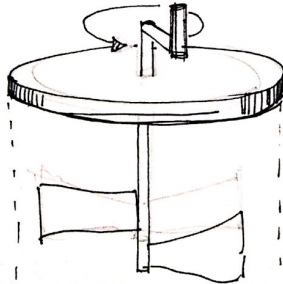

- Different ways by which food can be transferred

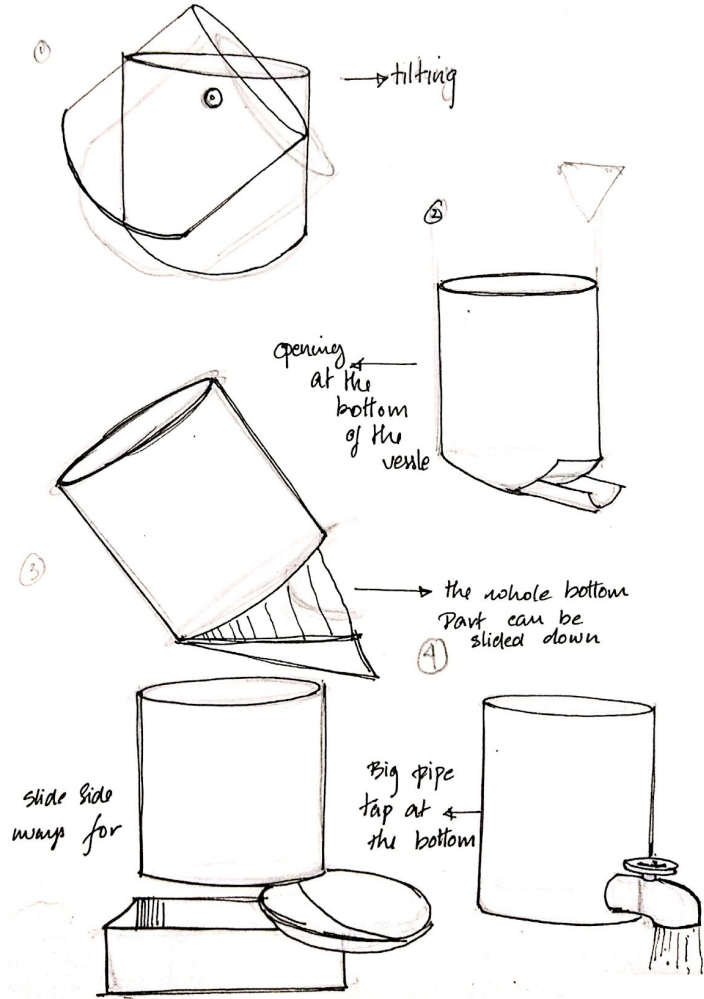

Different approach by which lid can be attached

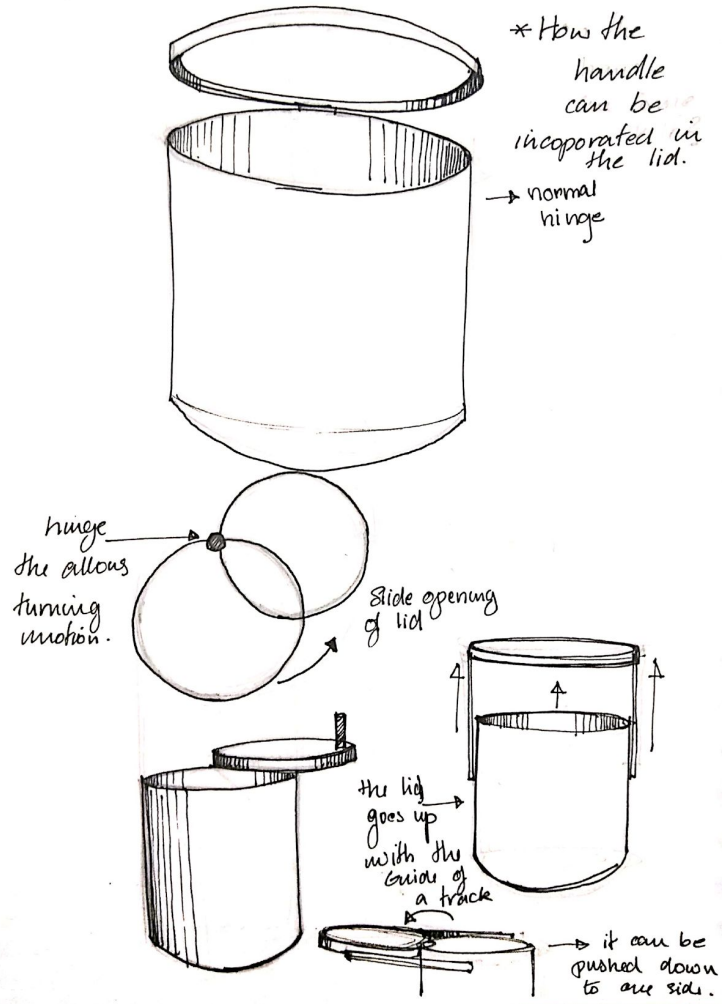

water inlet option

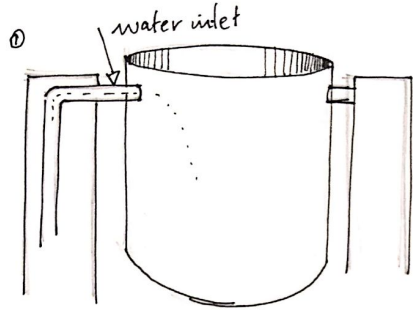

water inlet can pass through the main support for the vessel

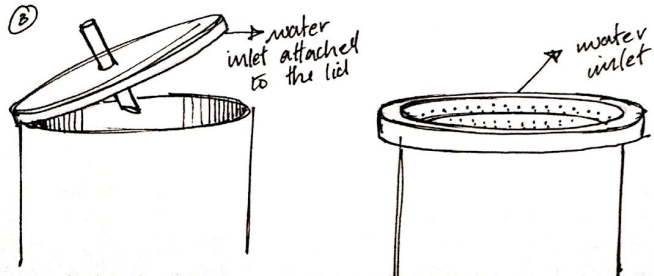
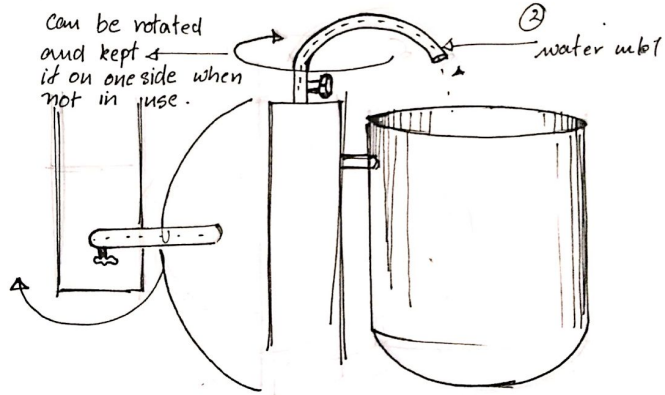

Draining of Steam water.

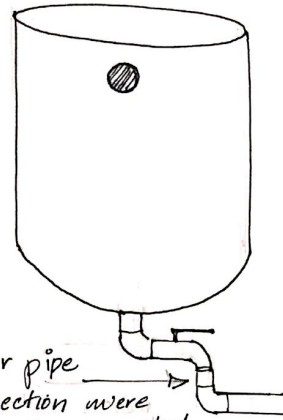

the opening of the valve should be kept at approachable distance.

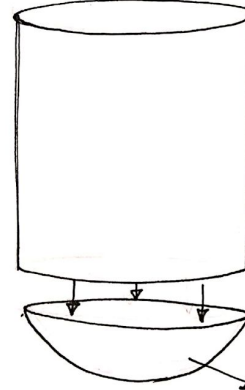
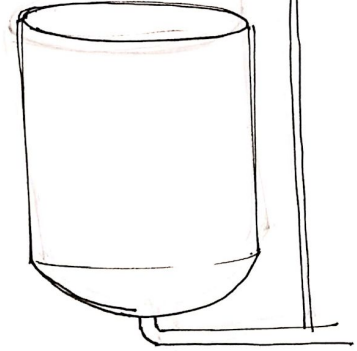

Removable steam water collector

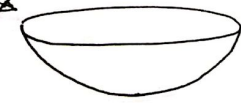

cleaning possible

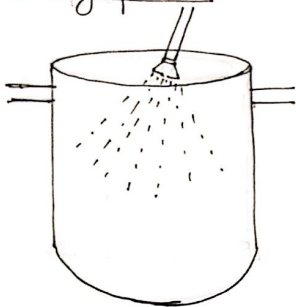

Something that can act as both inlet for water at the mean time can be used for cleaning.

openable vessel

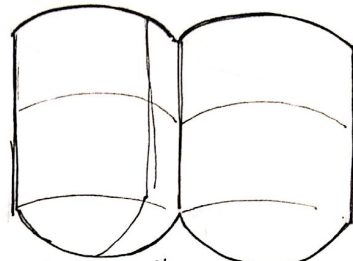
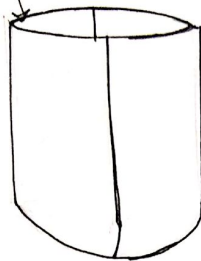

Making it easy to wash/clean

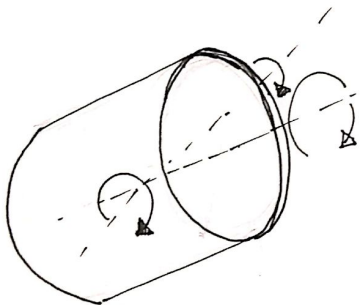

→ what if this vessel can be tilted and rotated.

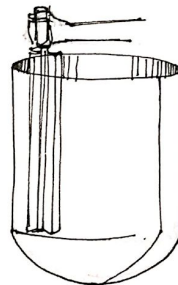
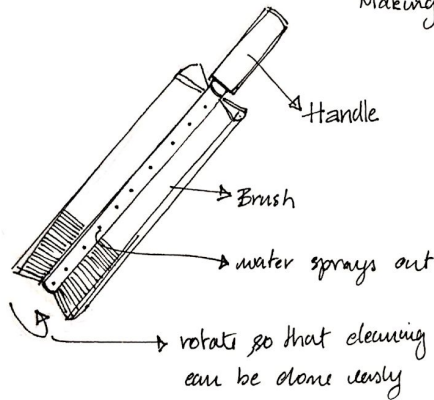

Automatic cleaning
Some action to the stirrer.

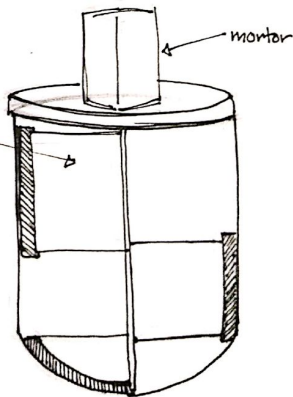

New head can be placed when cleaning is required.

Placement of Spoon

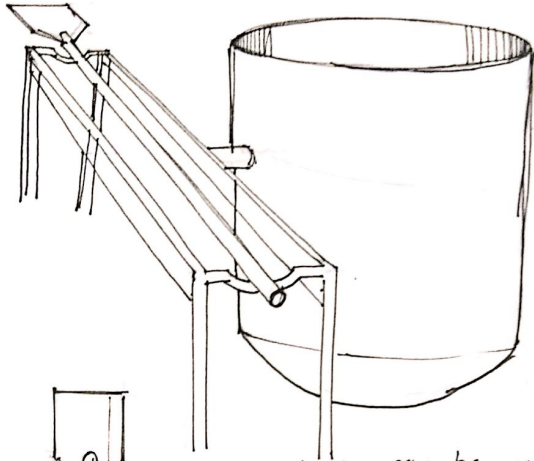

Spoon holder can be incorporated in the main structure that supports the vessel

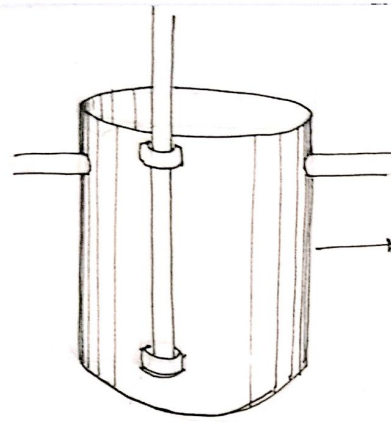
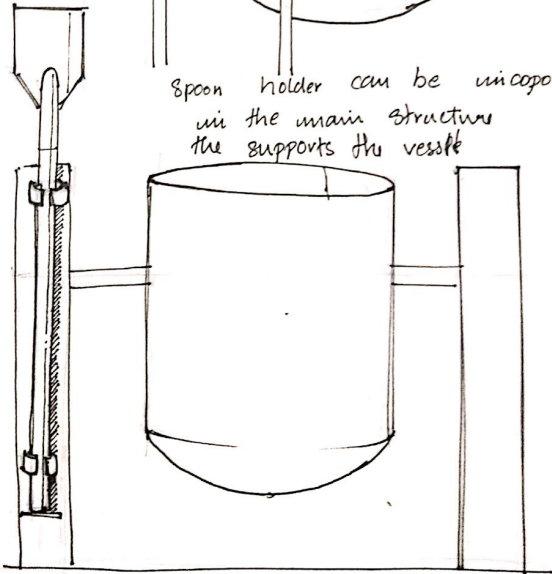

Spoon holder on the vessel

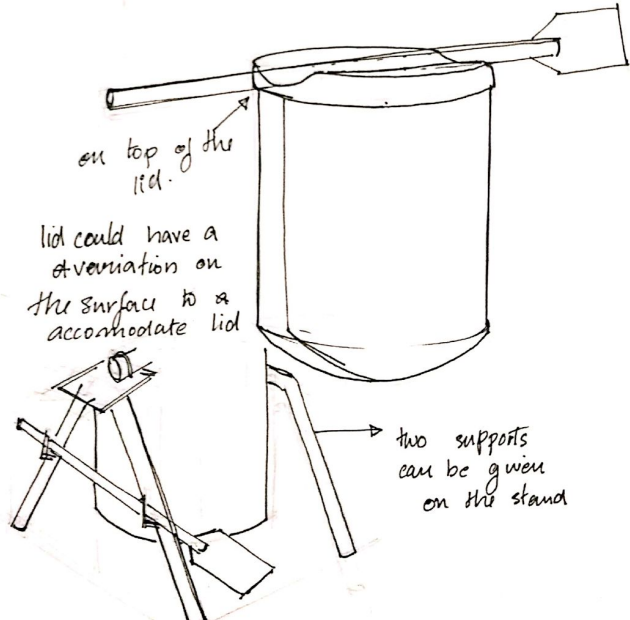

on top of the lid.

lid could have a deviation on the surface to accommodate lid

two supports can be given on the stand

Shape exploration

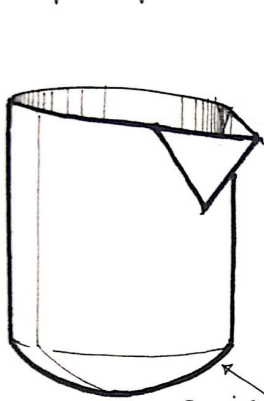

pouring can be made easy

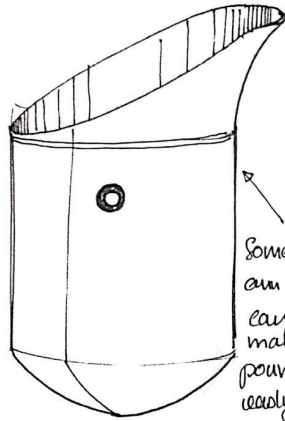

Some add on that can make pouring easy

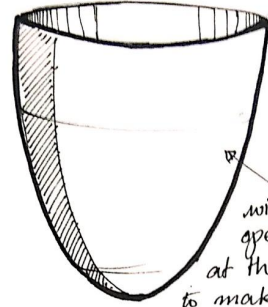
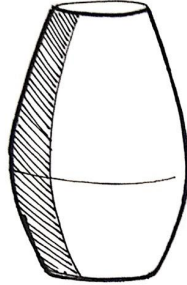

wider opening at the top to make transferring of food easy.

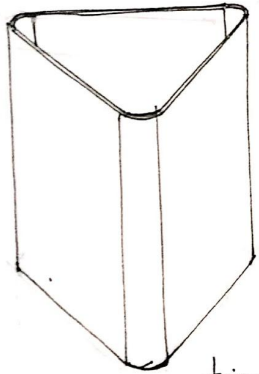

triangle shape with rounded corners pouring and cleaning will be easy

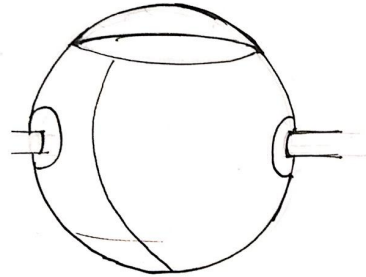
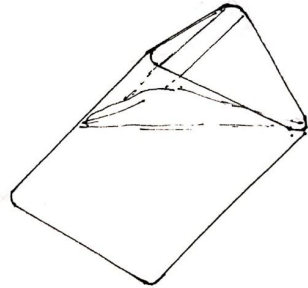

Cluster 1

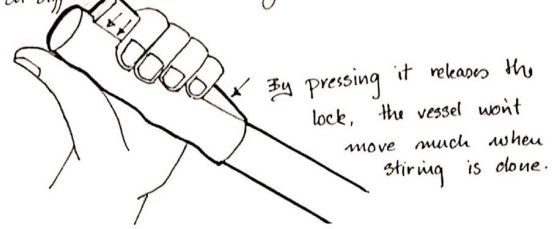
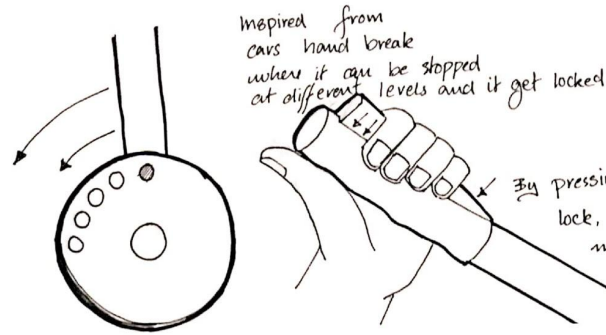
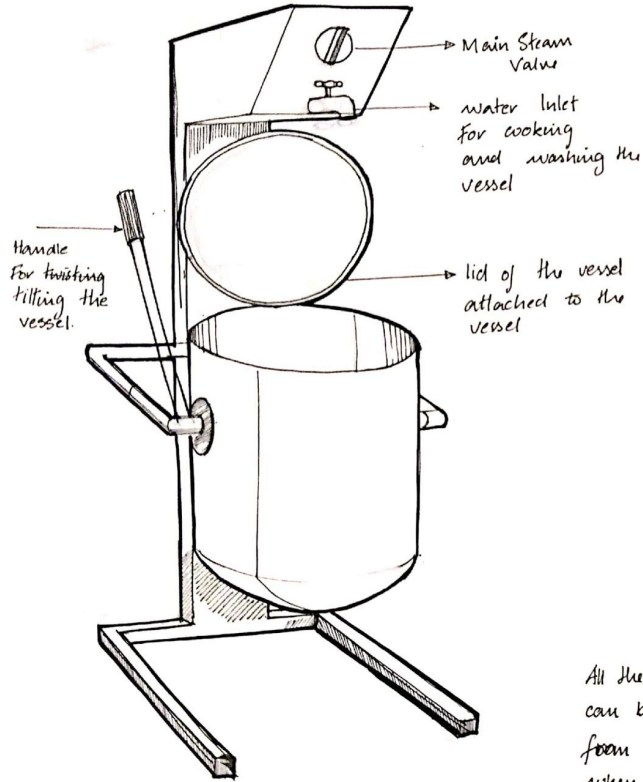

All the controls can be accessed from a single point where the user doesn't have to move much

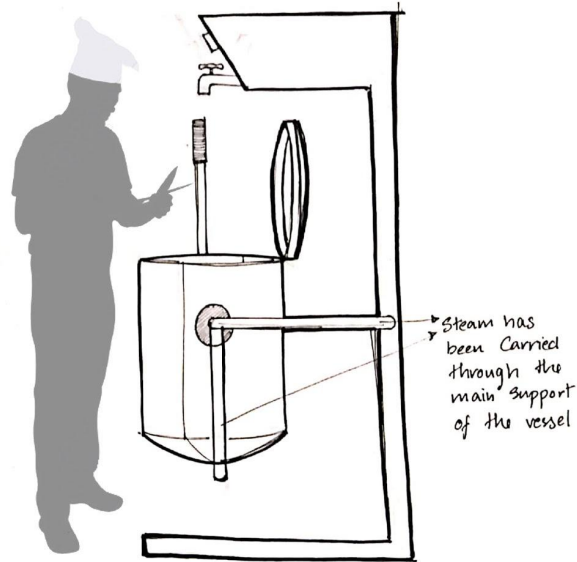

Cluster 2

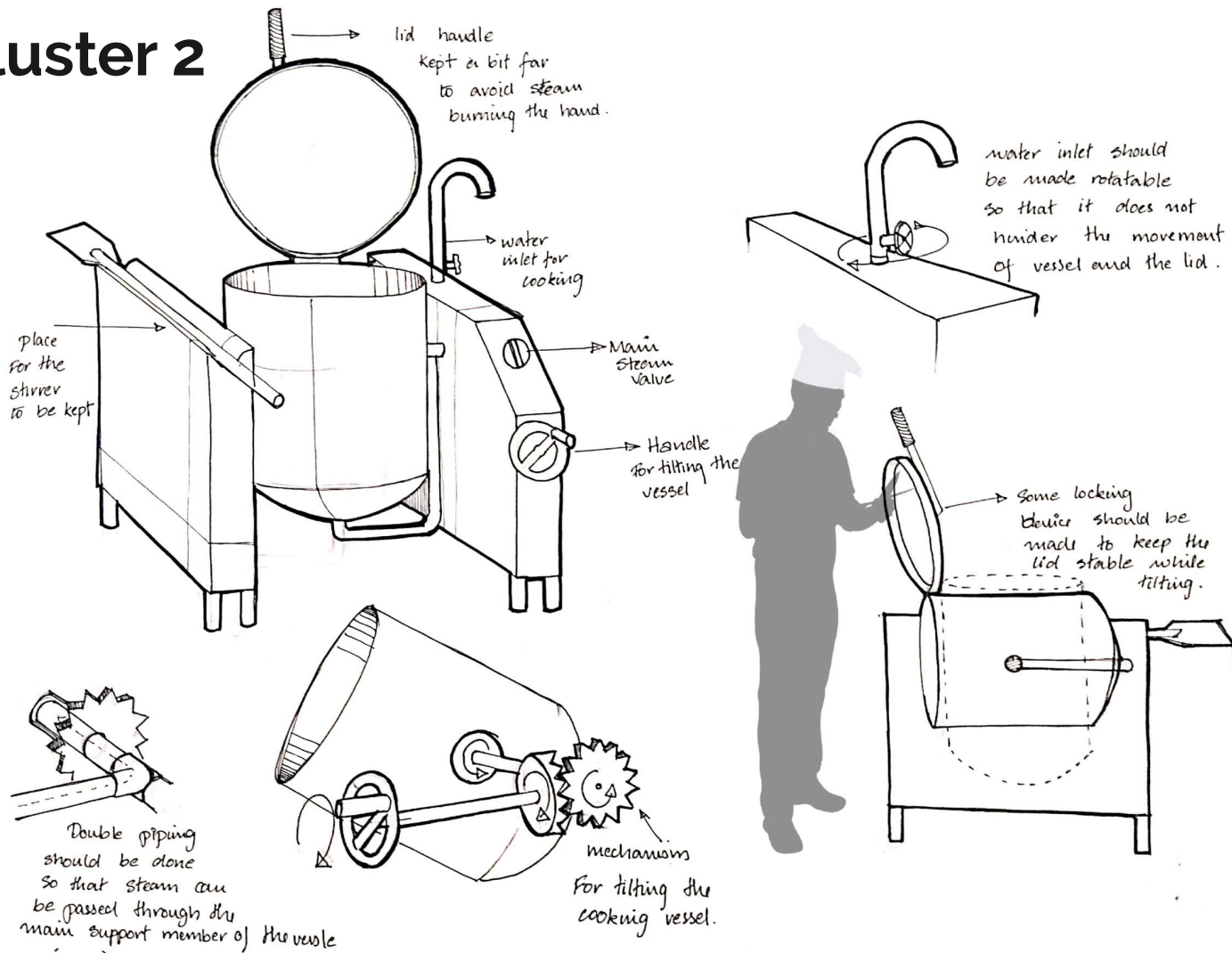

Cluster 3

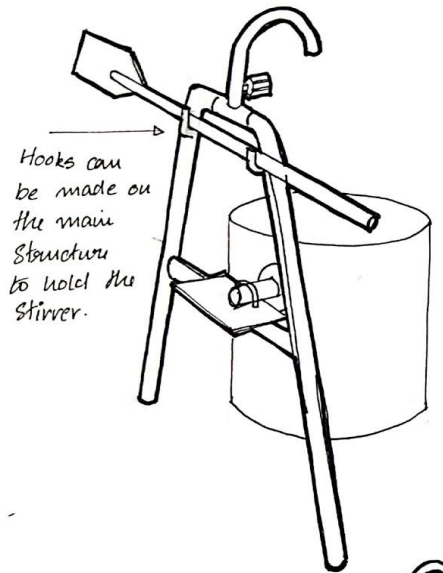
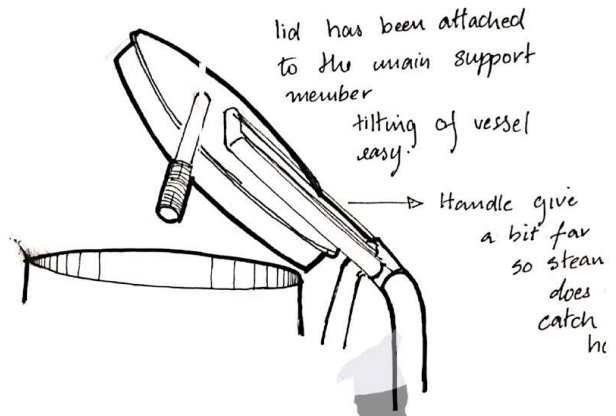
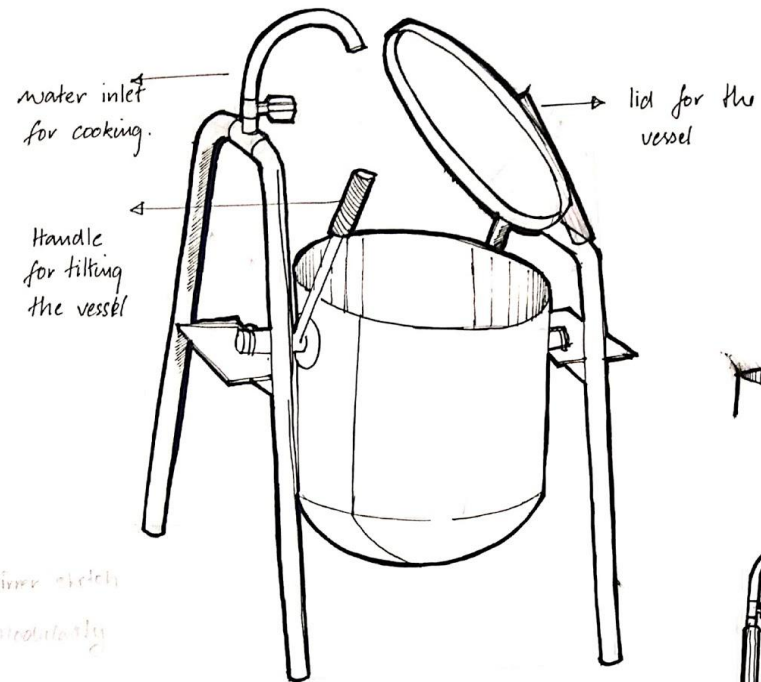

time with modularity

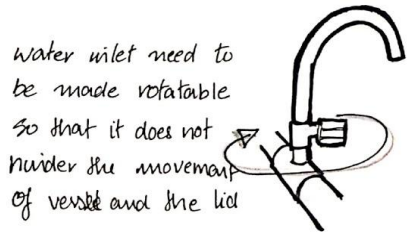

modularity need to be taken into consideration.

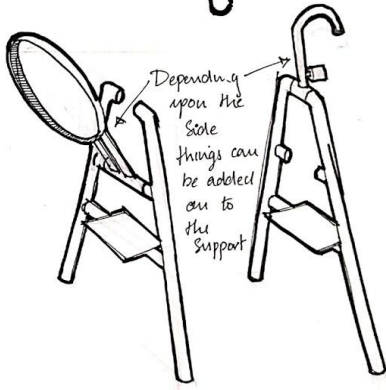
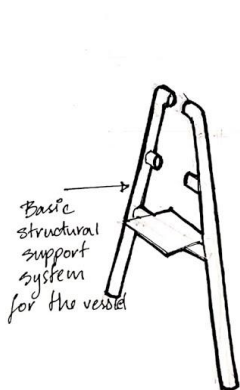
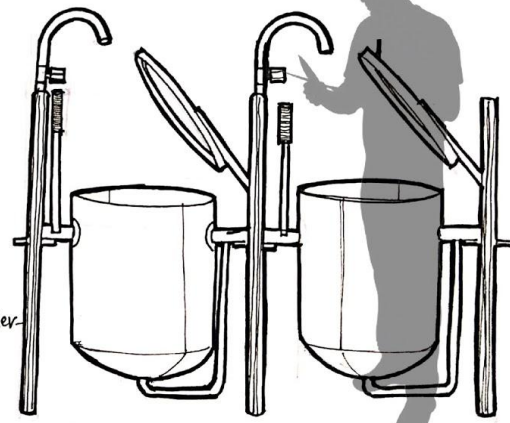

Cluster 4

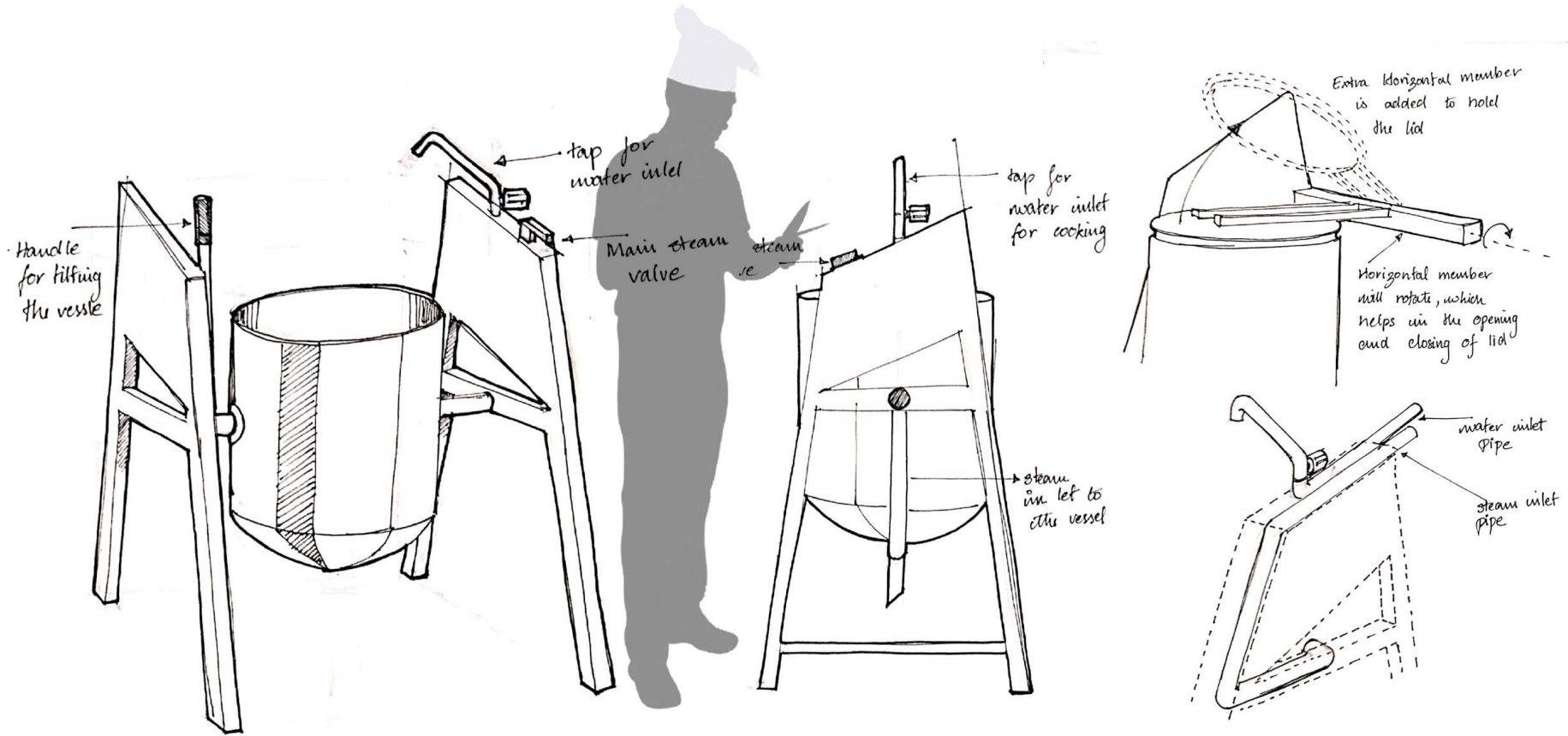

Cluster 5

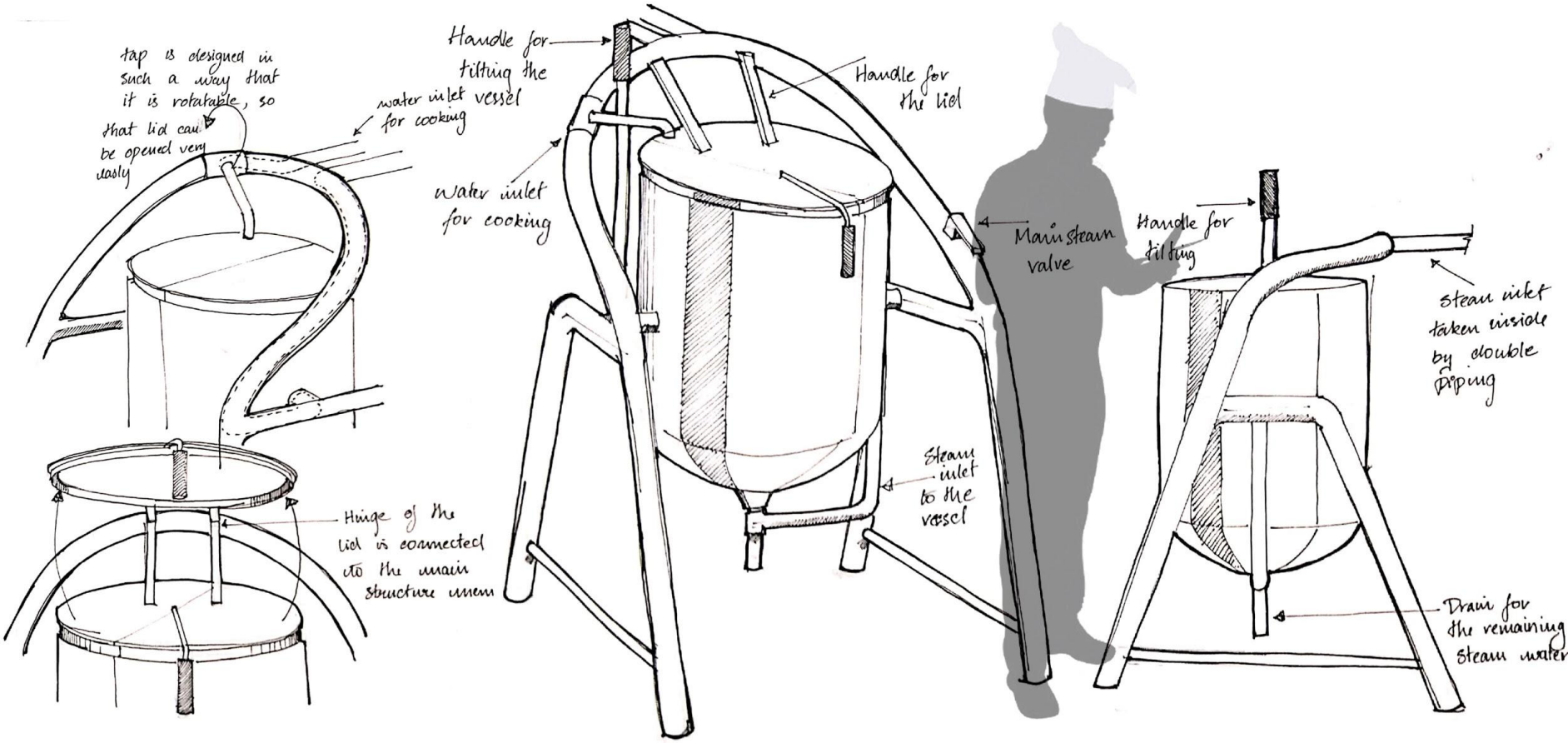

Final amalgamation of ideation - Concept

From the initial ideations and the inference made from those, the final concept has been arrived. The idea was to keep all the main controls and valves in a single side rather than scattering them all over which makes it easy to handle the device and to keep the design as simple as possible.

Concept

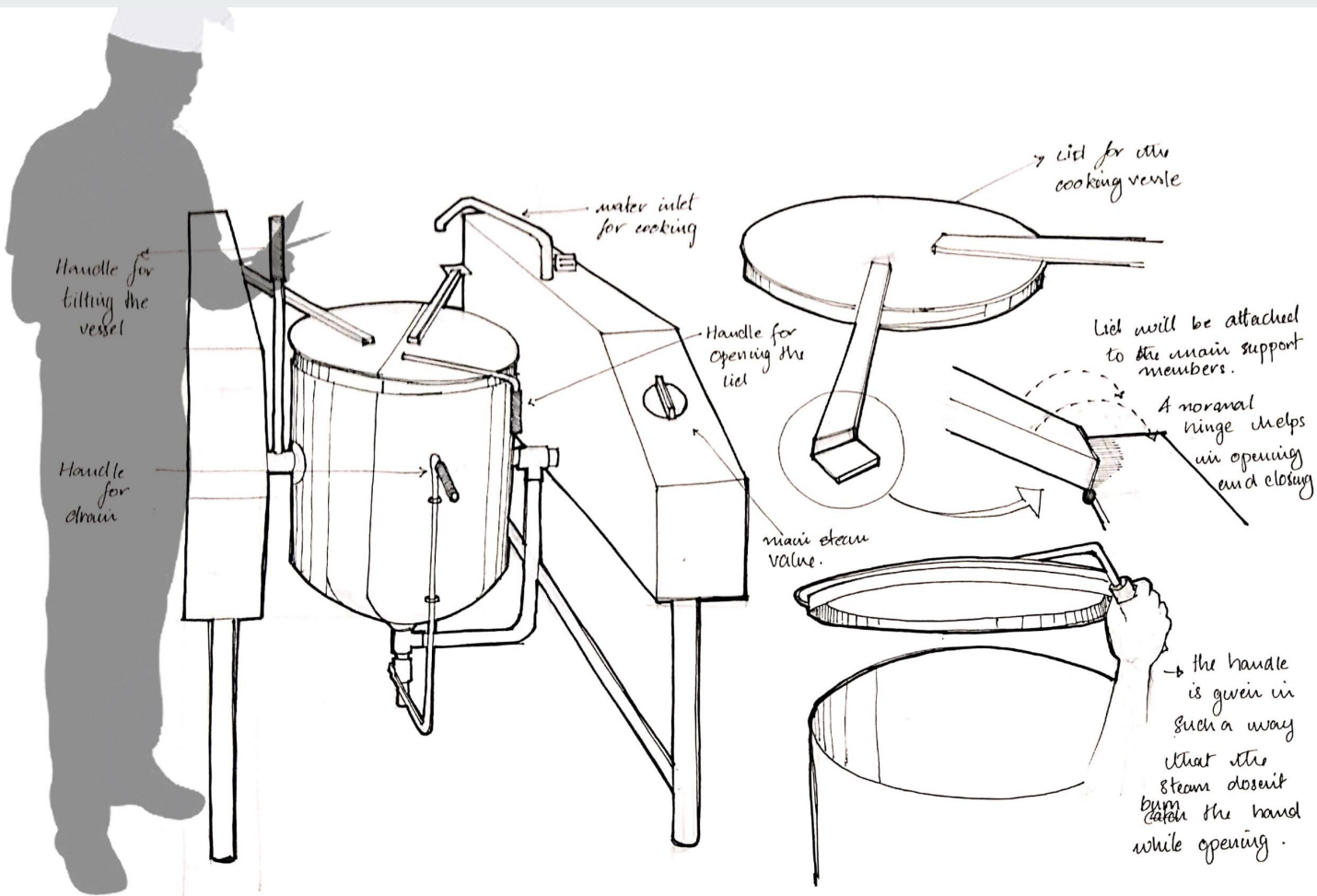

Concept

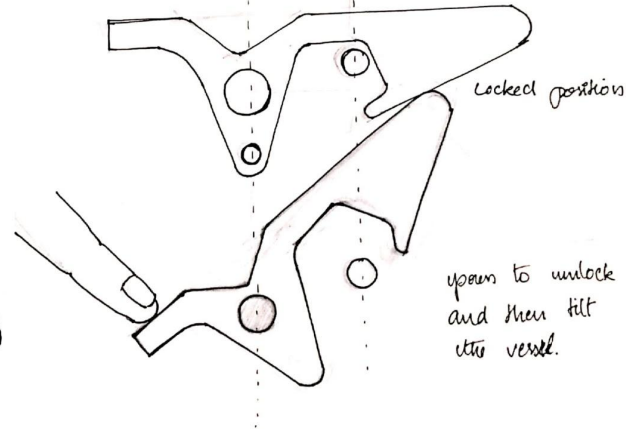
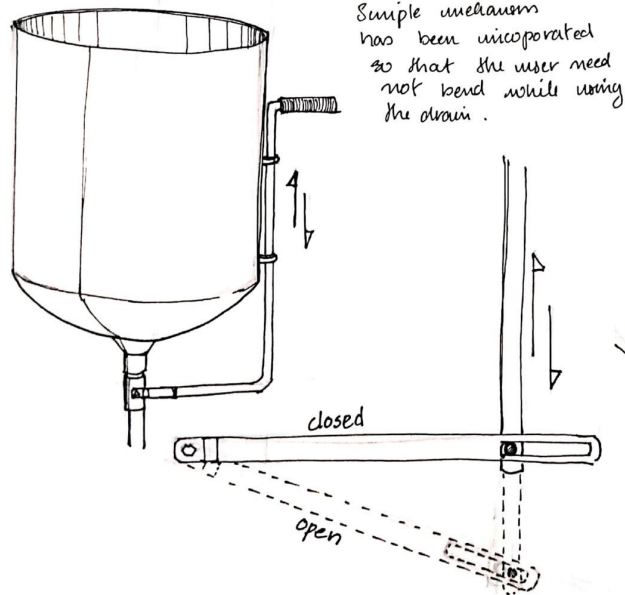
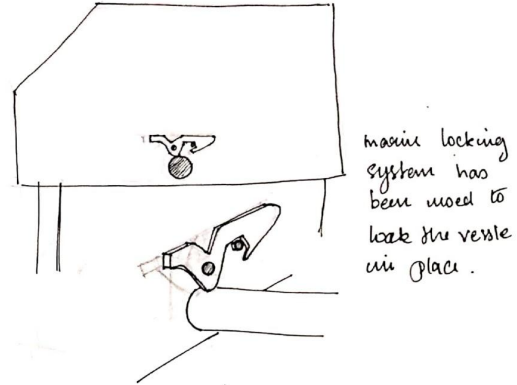
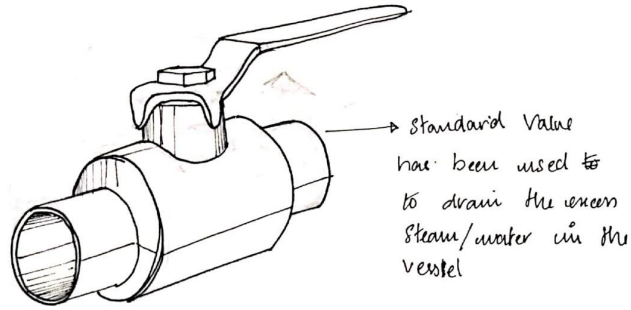

Concept

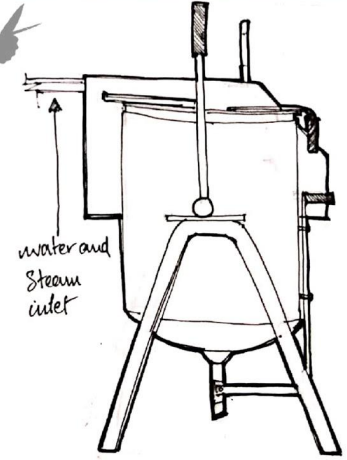
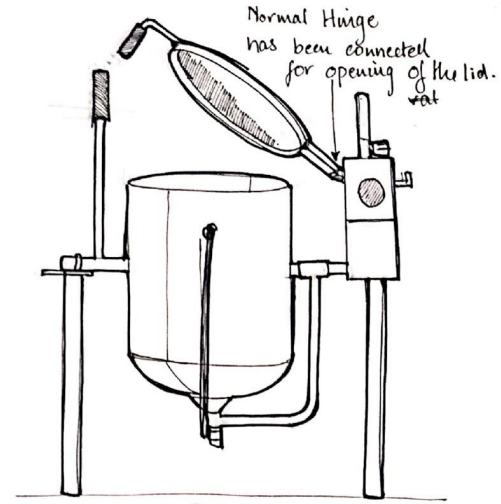
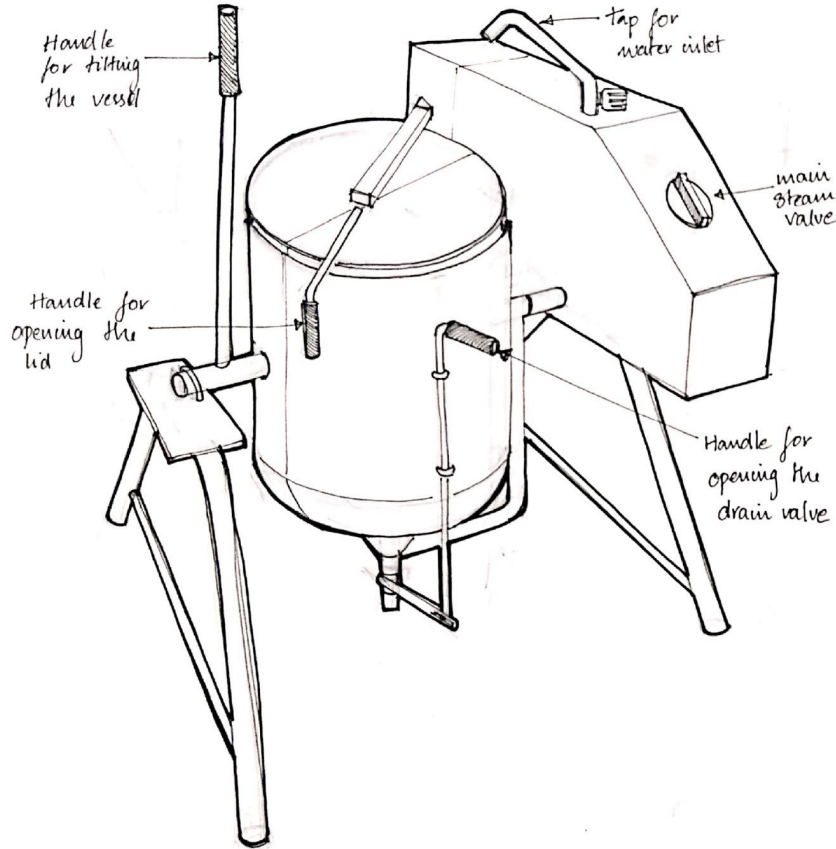

Concept

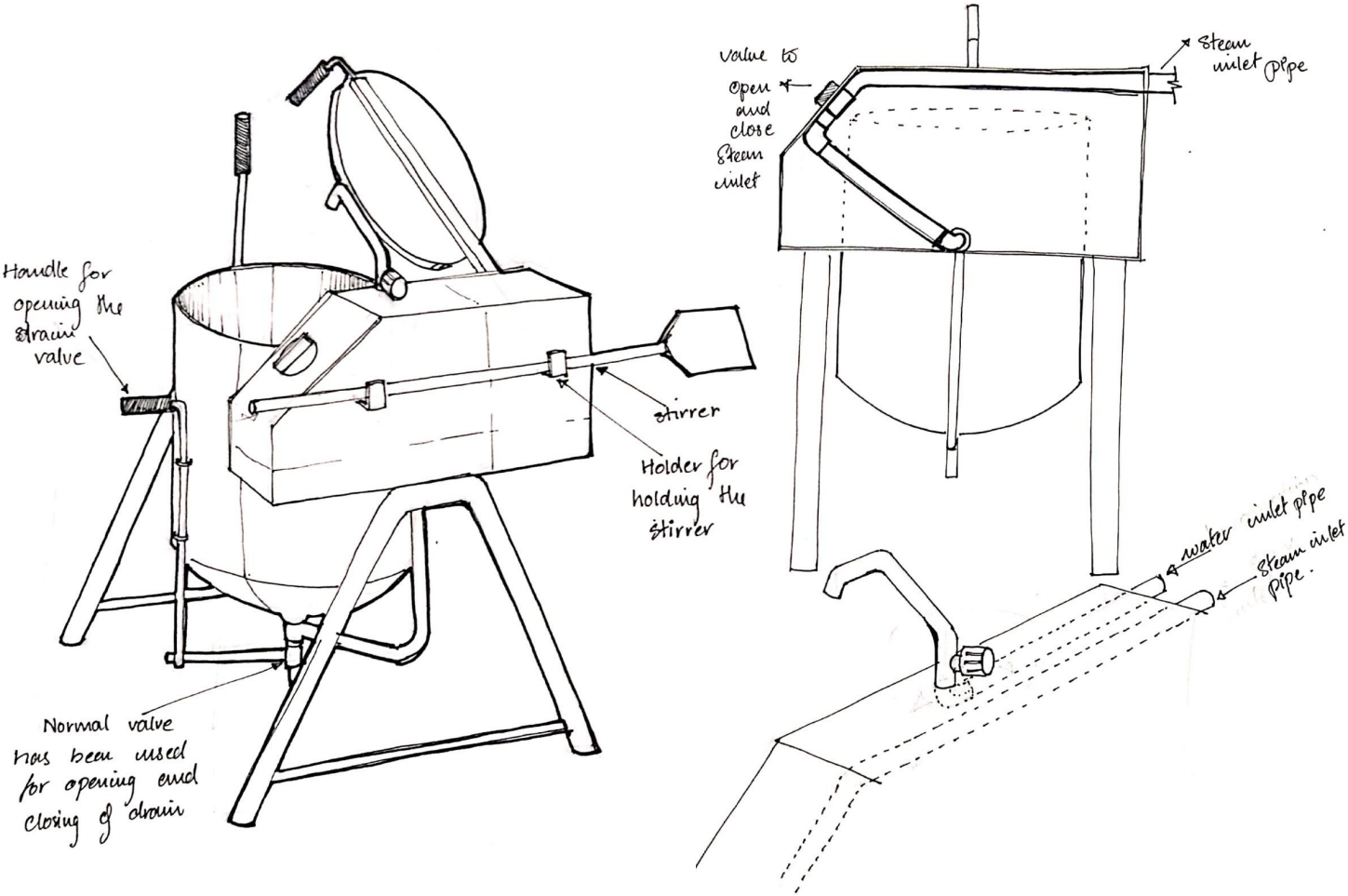

Concept

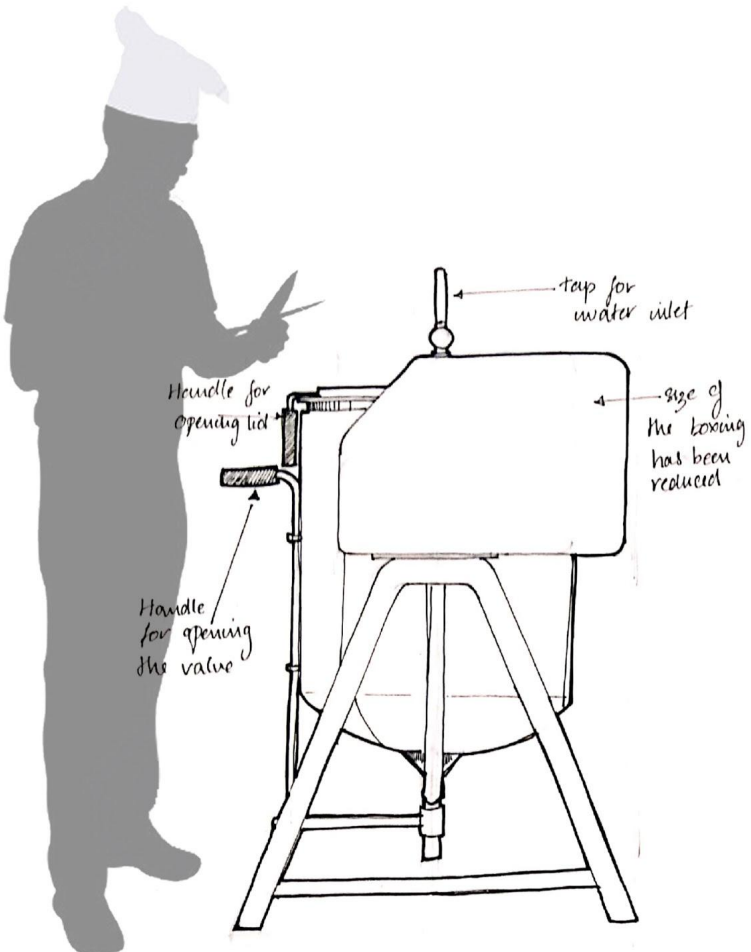
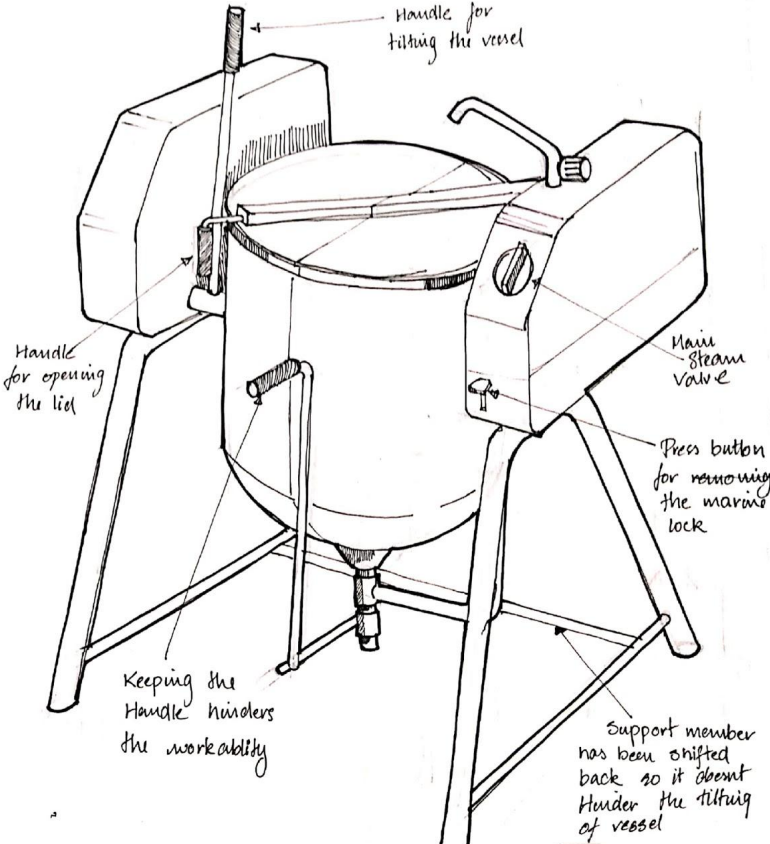

Concept

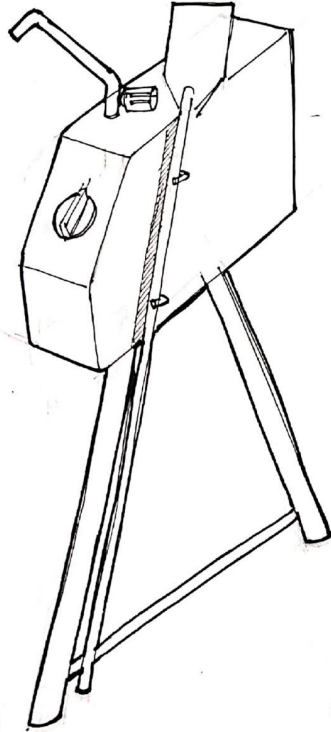
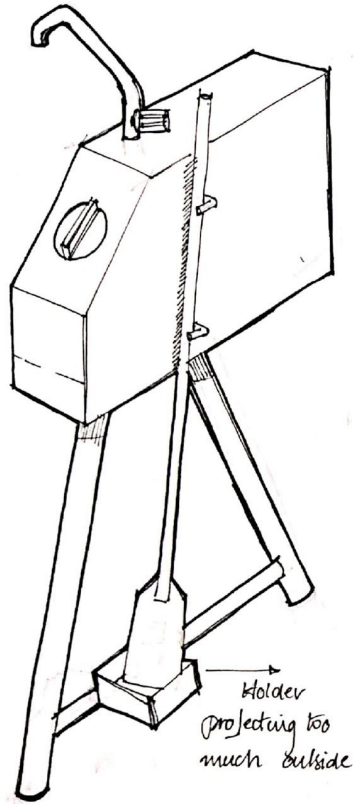

changing the form of the boxing

Giving the handle at the inner end of the box

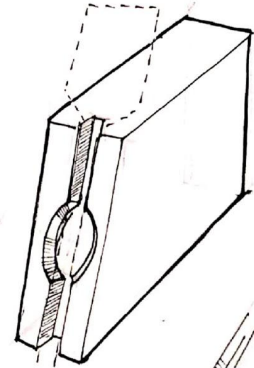

For easy grabbing of stirrer

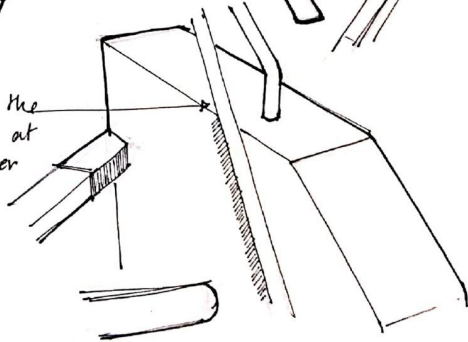

Concept

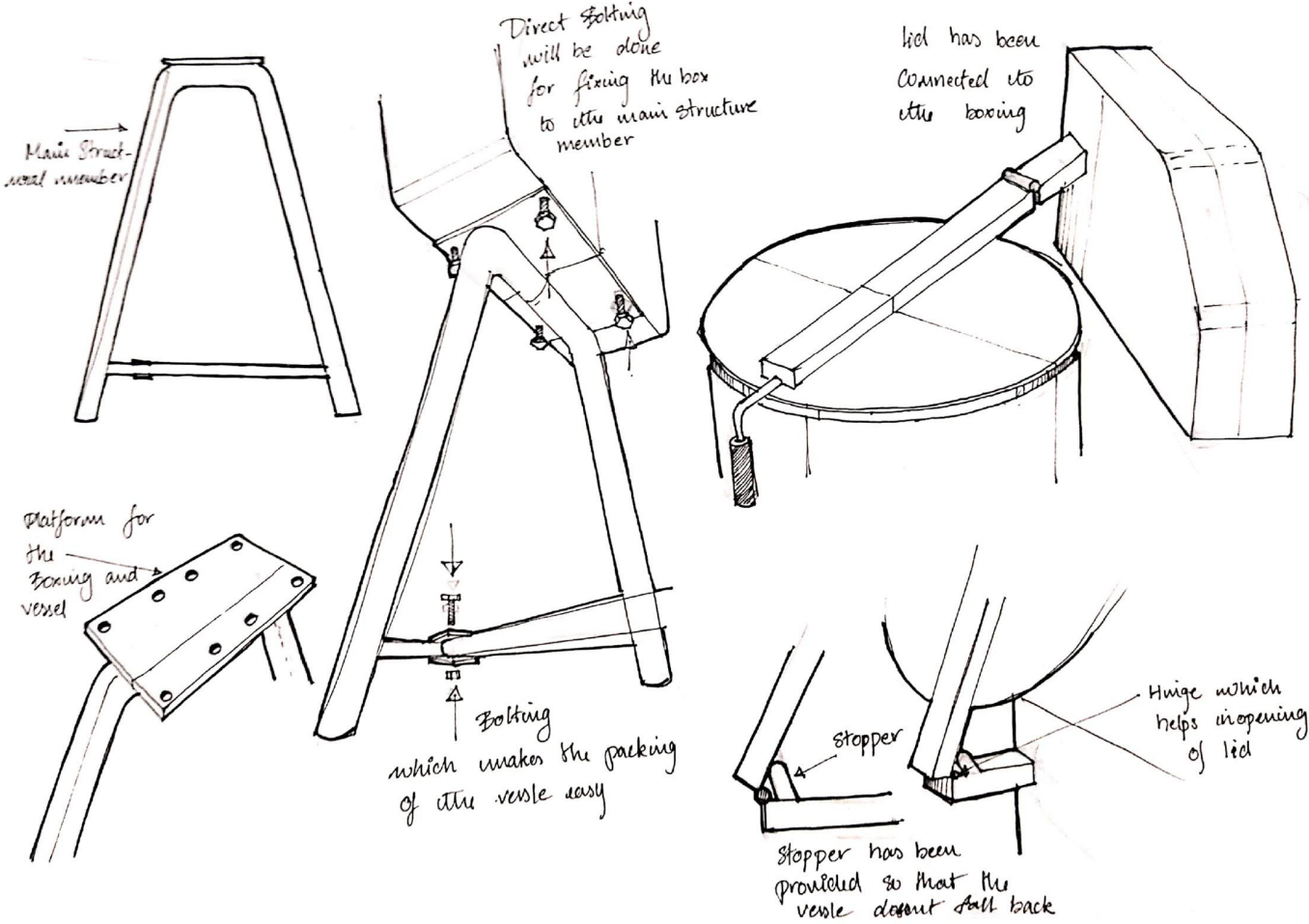

Concept

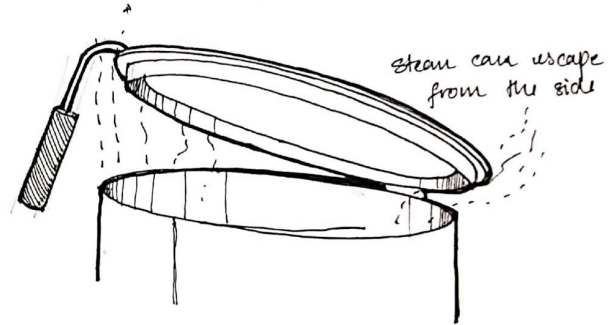
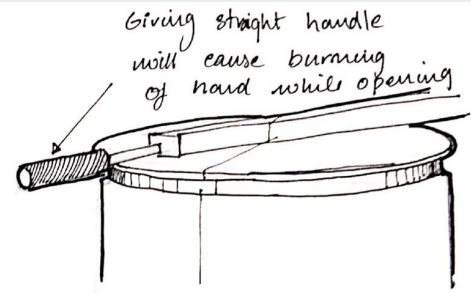
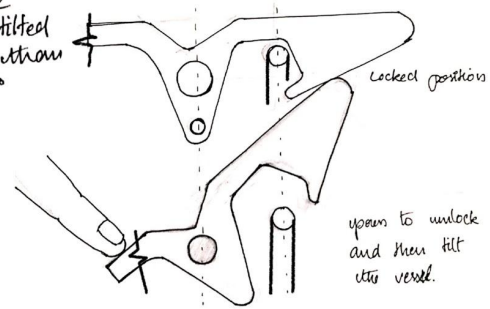
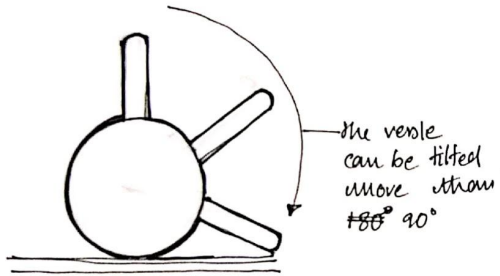
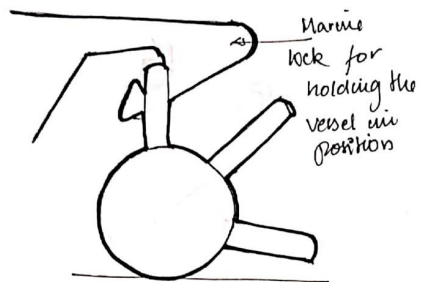
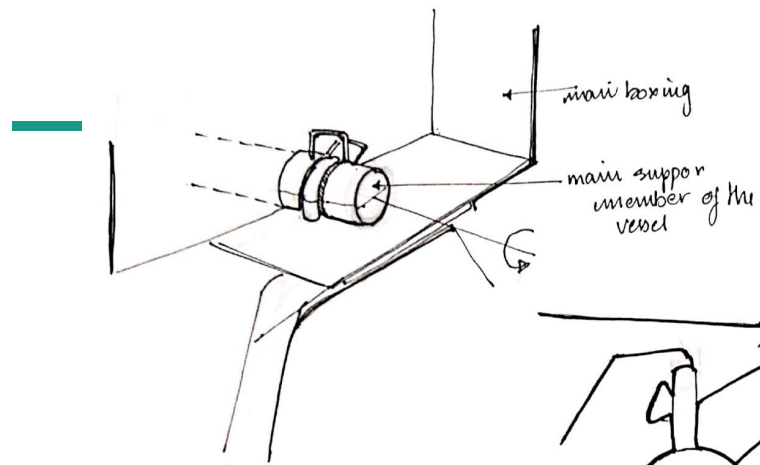





Ergonomics in the design.

The combined height of 50th percentile 1619mm has been taken as the height to check the ergonomics of the vessel considering the average height of men is 1649mm and women is 1526mm of Indians. When analysed with ergonomic data it has been found that reachability of the lid handle is an issue.

Parameters		Percentiles		
		50 th	75 th	90 th
Stature (Height)	Male	1648	1691	1781
	Female	1517	1567	1632
	Combined	1619	1673	1771
Span	Male	1684	1739	1829
	Female	1549	1599	1679
	Combined	1659	1724	1809
Acromion to styliion length (hand length)	Male	555	583	645
	Female	516	557	606
	Combined	548	579	635
Hand length	Male	180	187	198
	Female	166	170	181
	Combined	176	184	197

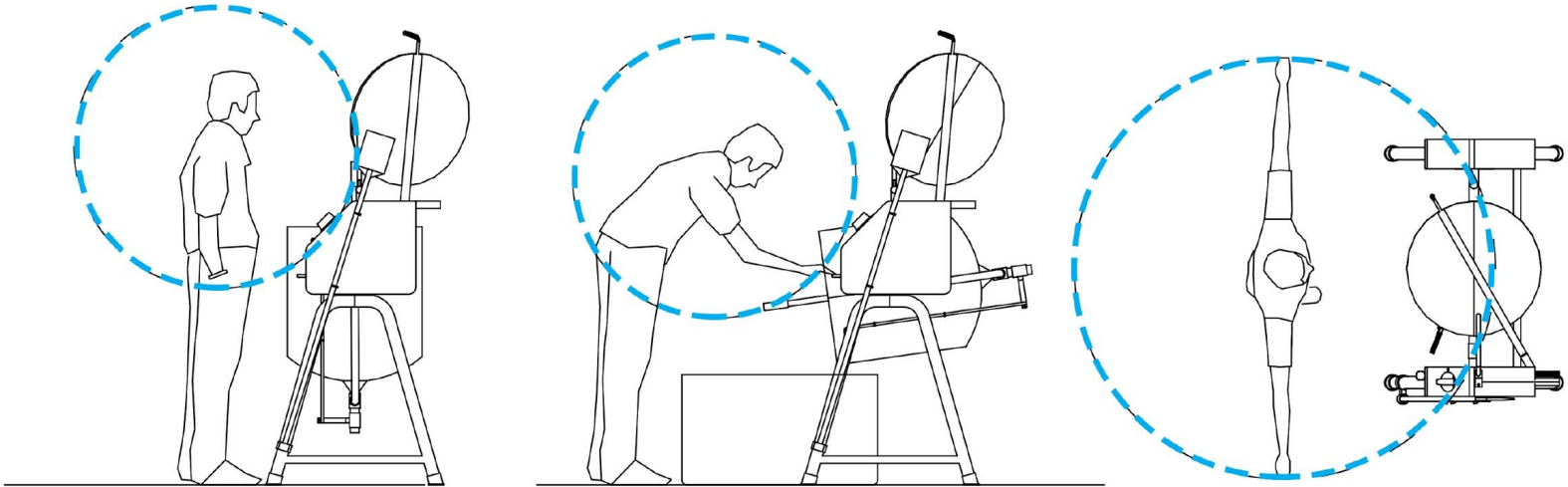

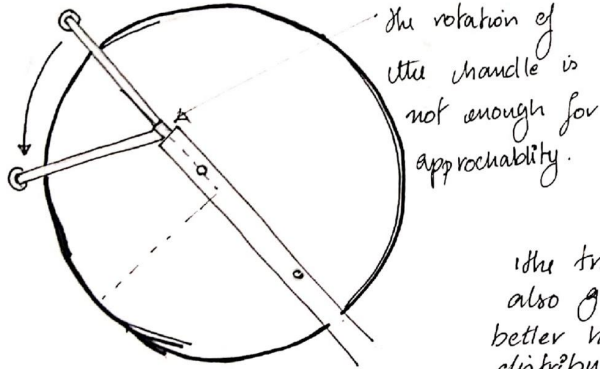
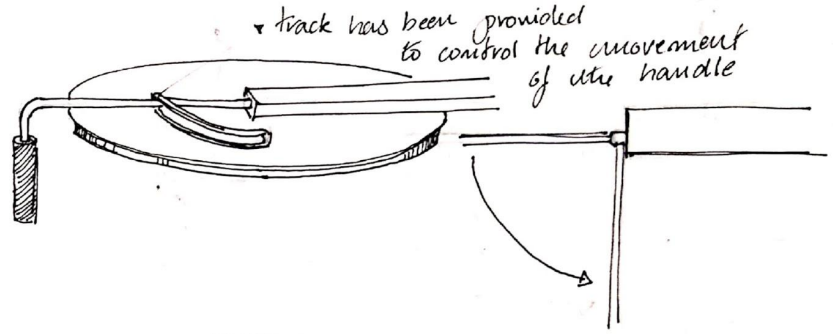
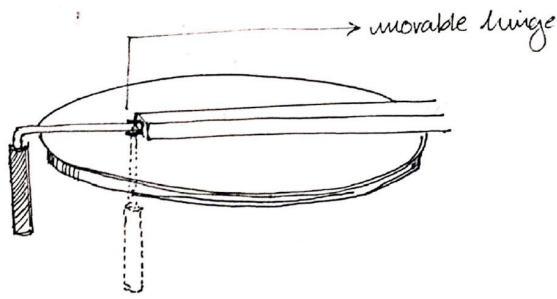

the track also gives a better hold and force distribution on the lid when lifted.

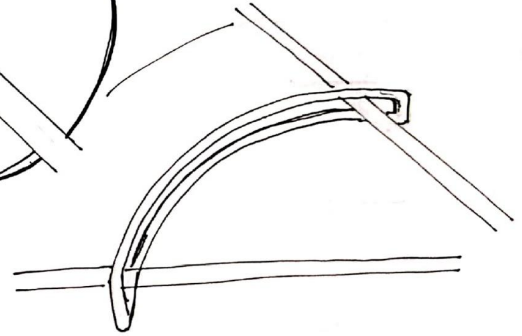
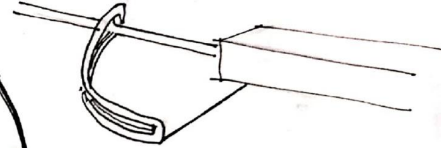
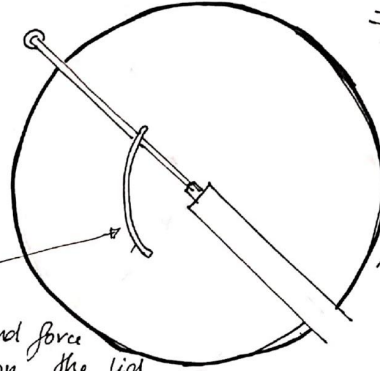

Detail of the unmovable hinge

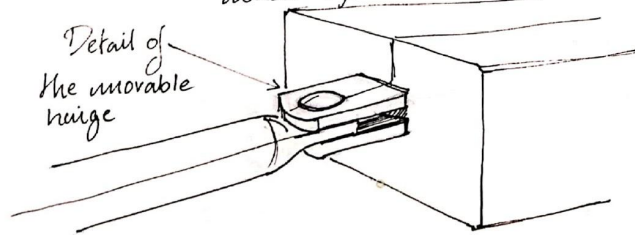

An option when handle
is given in front
is tried



Major issue is
Steam falling
onto the
handle

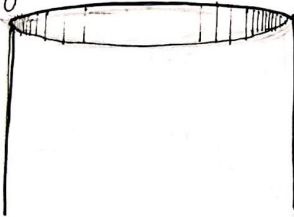

Trying to
keep the mechanism
inside the box it
does not give much
freedom for opening

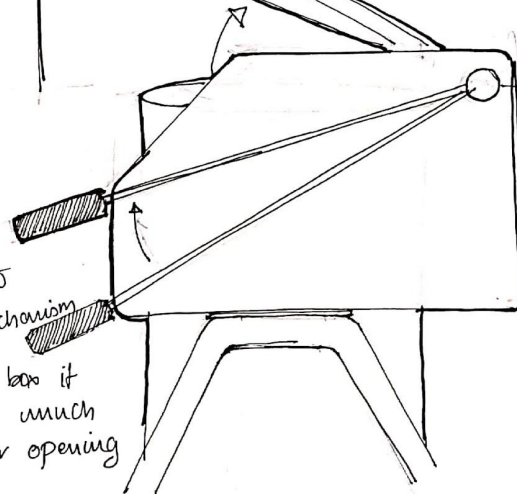

Handle has been
connected to the back
support. so that when
the handle is lift
lid opens.

If a bigger to
smaller gear
system is provided
the opening of the
lid can be
managed.

Knob design ideation.

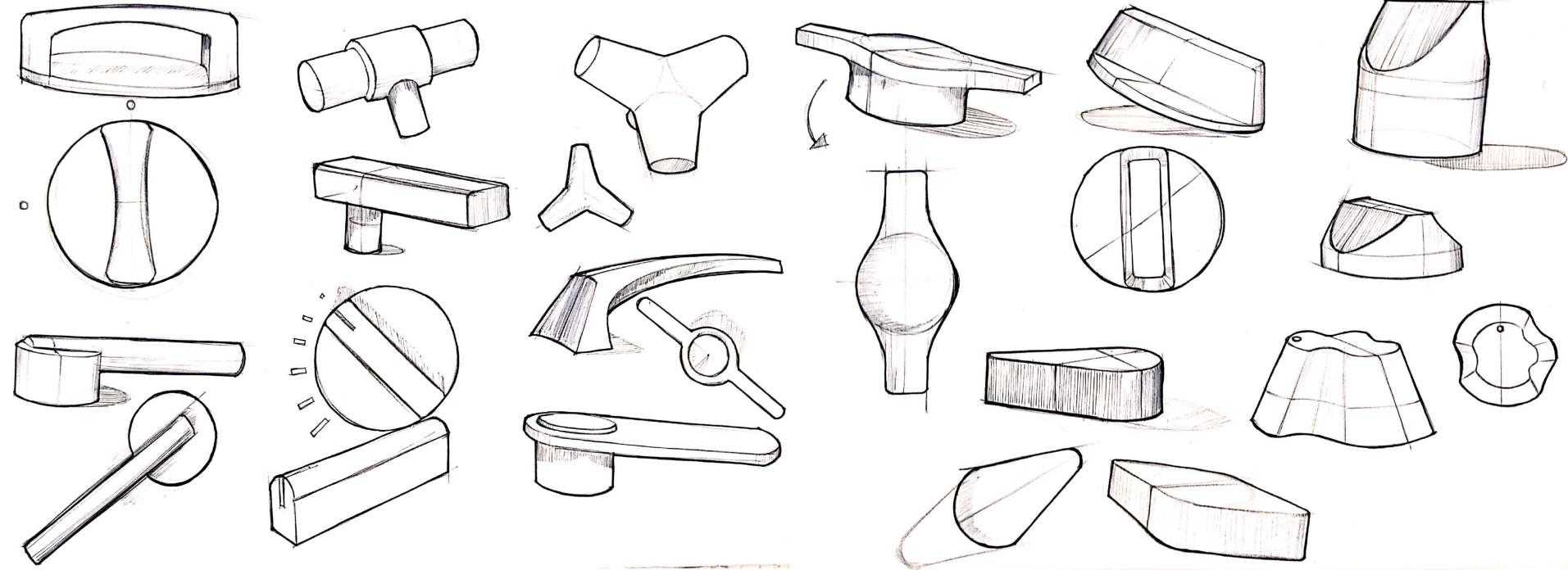

Handle design ideation.

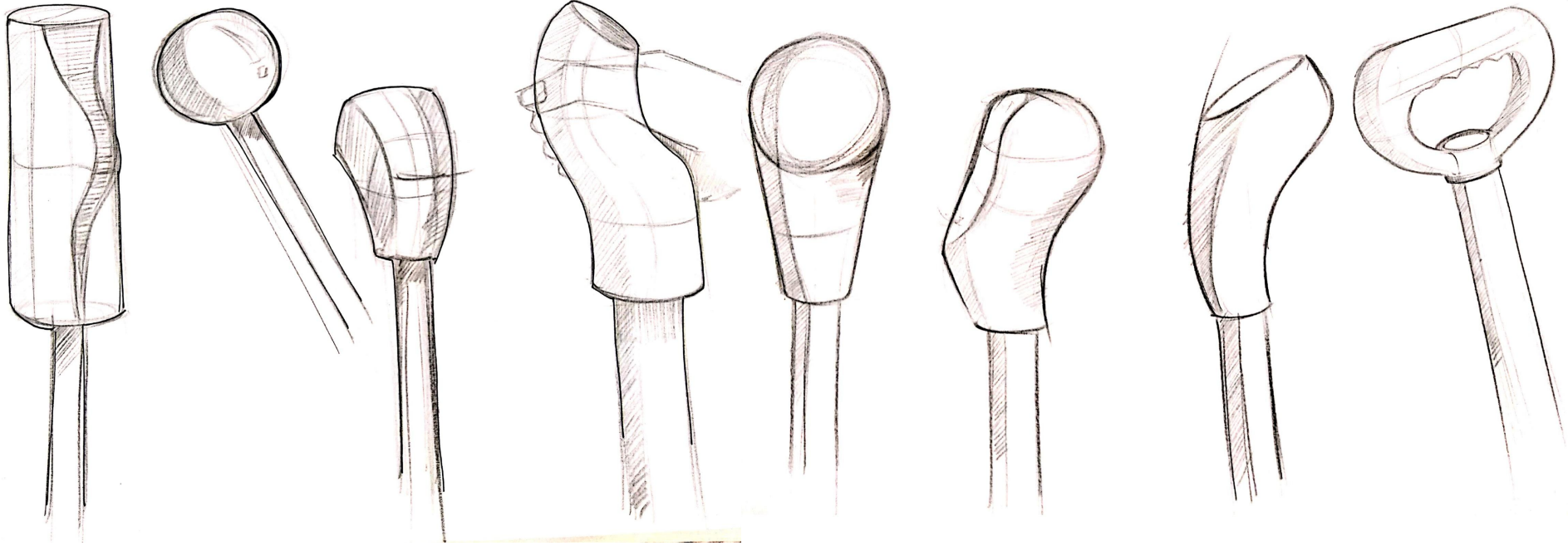

Handle design ideation.

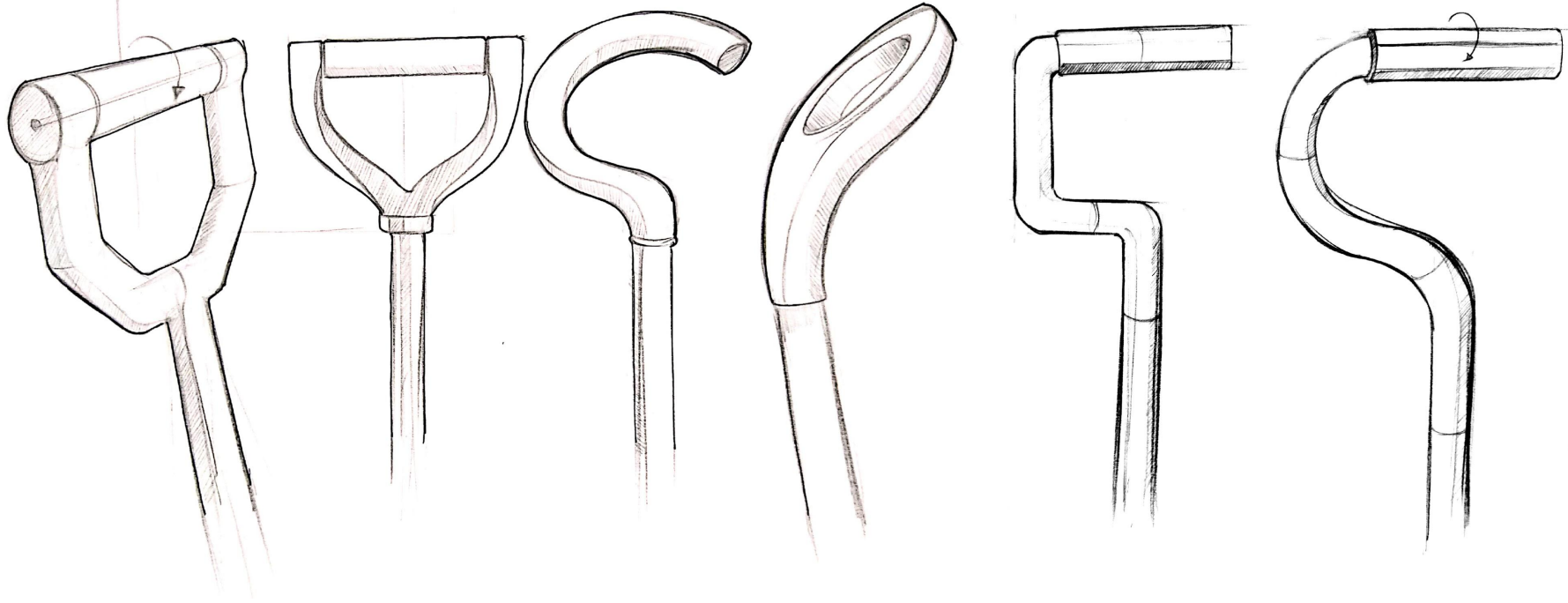

Handle design mockups.

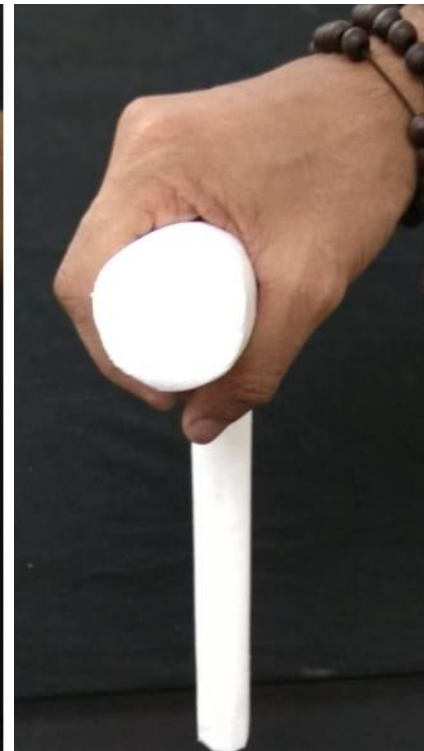



Final Design



Process

Water being poured into the vessel

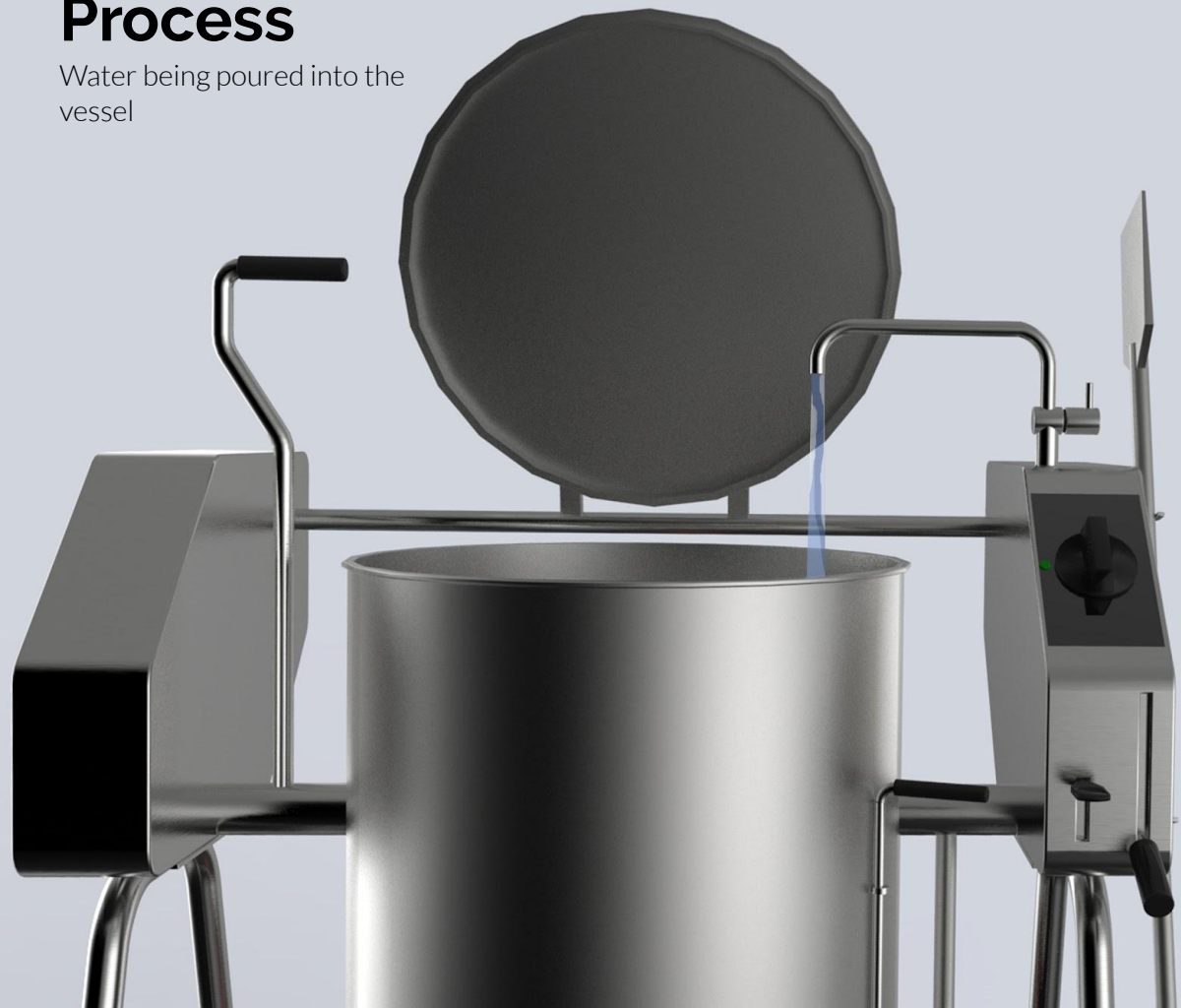

Turning the steam valve on.

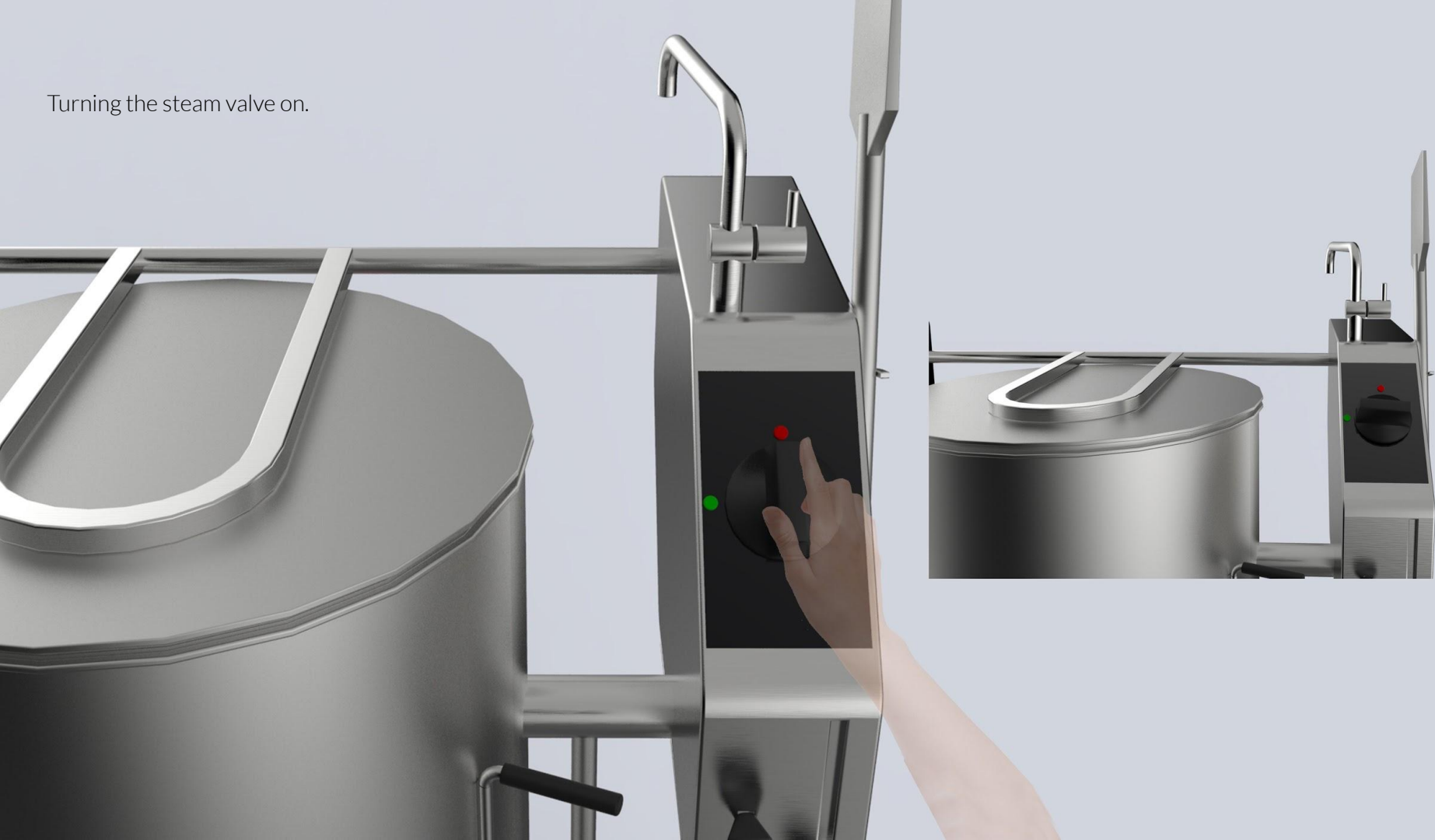

Putting the rice into the vessel

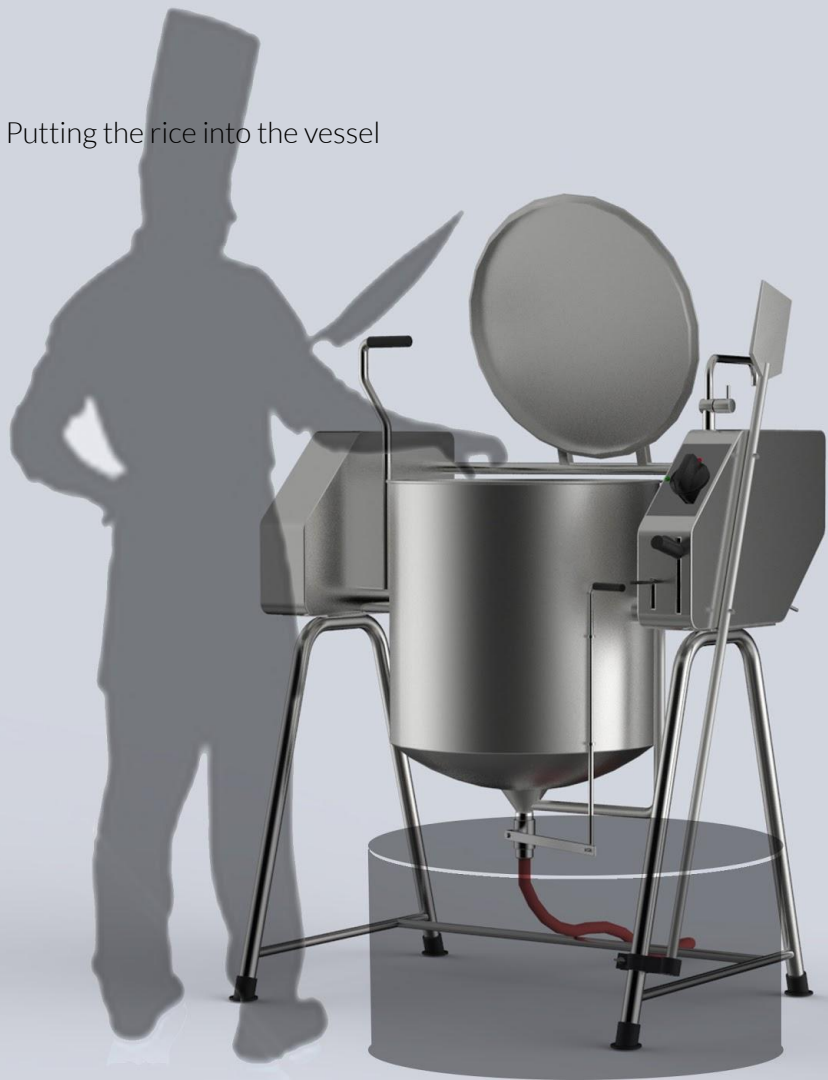

Using the stirrer for stirring

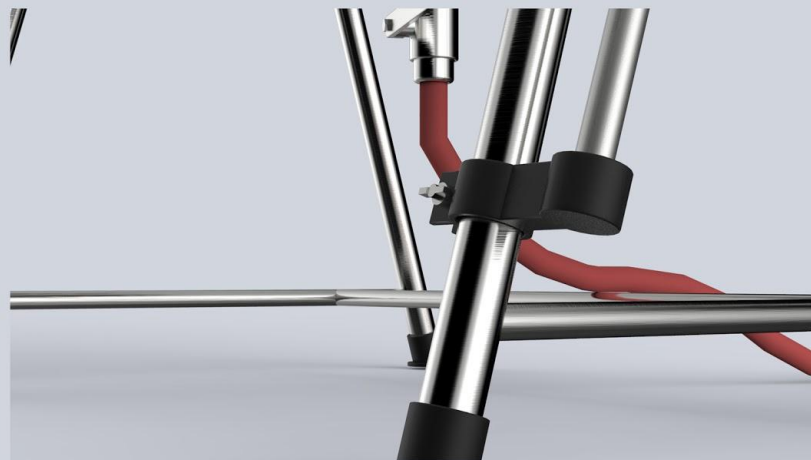

Detail showing the detail of the holder for the stirrer.



Turning the drain valve on for removing the waste water

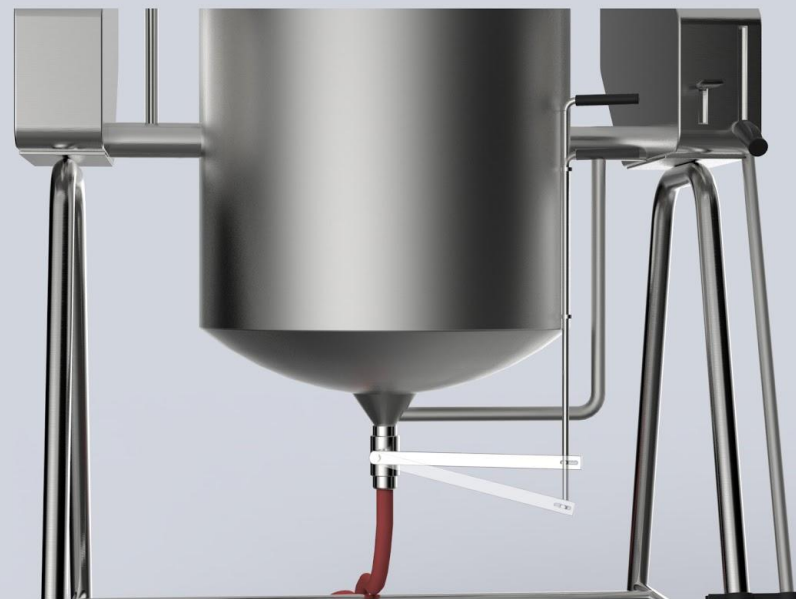

Pressing the knob of the
marine lock and tilting the
vessel for transferring the food

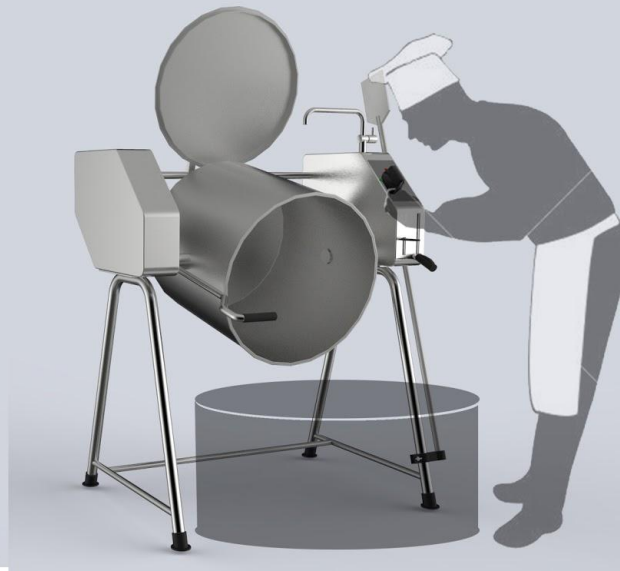
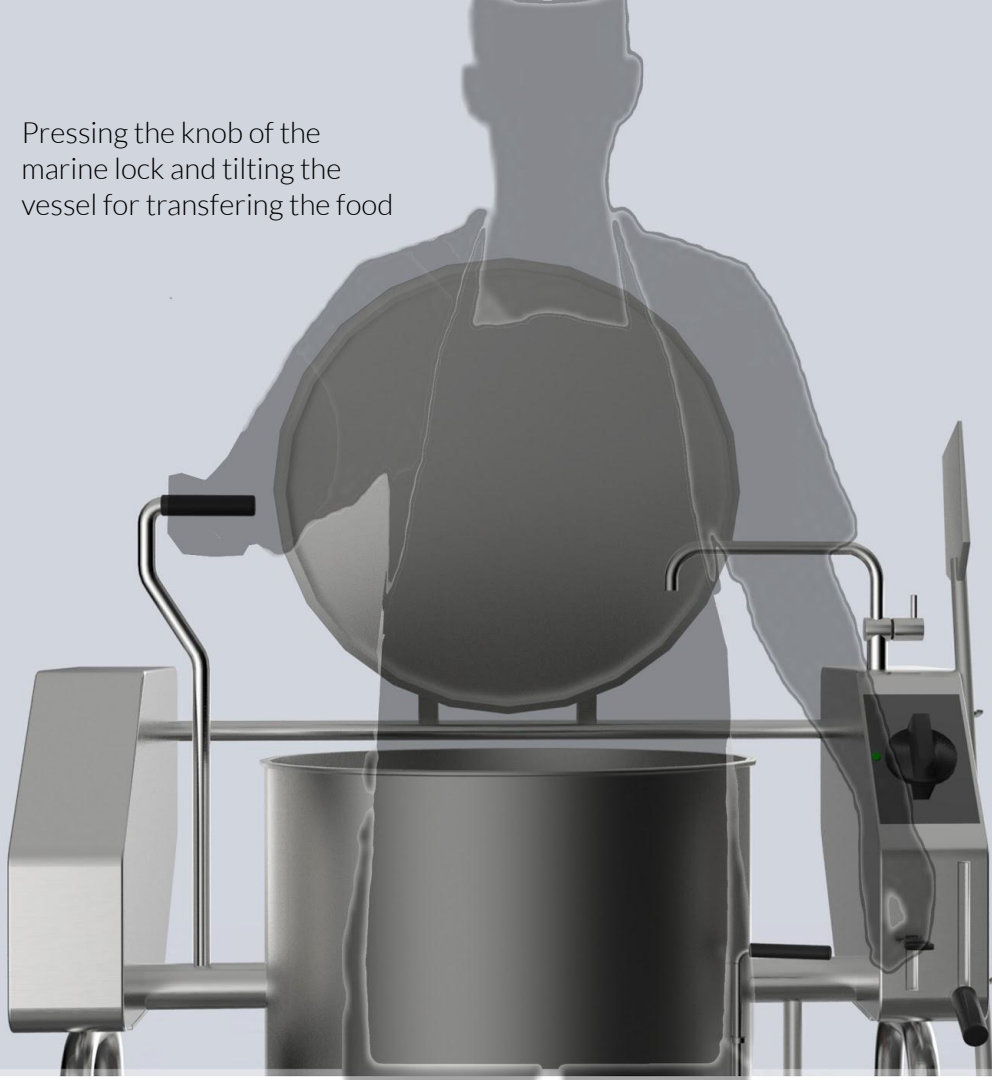

Working of the lid mechanism



Mechanism for tilting the vessel.



Achieving modularity in design.





Thank you