



vidya joshi

02613013

SUMMER TRAINING AT WHIRLPOOL OF INDIA LTD.

THE WHIRLPOOL EXPERIENCE.



The time that I spent at whirlpool this summer was very enlightening and informative. It gave me an opportunity to see, observe and actually be a part of the industrial set up. It helped me to understand the working of a multinational company and gave valuable insights in the latest materials and production technology in refrigerators. It made me aware of the current scenario in product design and development in the refrigerator industry. More importantly, it made me realize the role of a designer in the whole set up ---design is a teamwork of people from diverse fields of industrial design, engineering and marketing.

One month is a short time to get into depths of any project, but it definitely gave me an overview of how it all works in the appliance industry .

I would like to thank Mr. Sushant Jena from the Product development Centre, Whirlpool of India, Ranjangaon for his guidance. I would also like to thank the HOD, the faculty and staff of IDC for their help and support.

SUMMER TRAINING AT WHIRLPOOL OF INDIA LTD.

ABOUT WHIRLPOOL

Whirlpool Inc, US is one of the leading manufacturers and marketers of major home appliances.

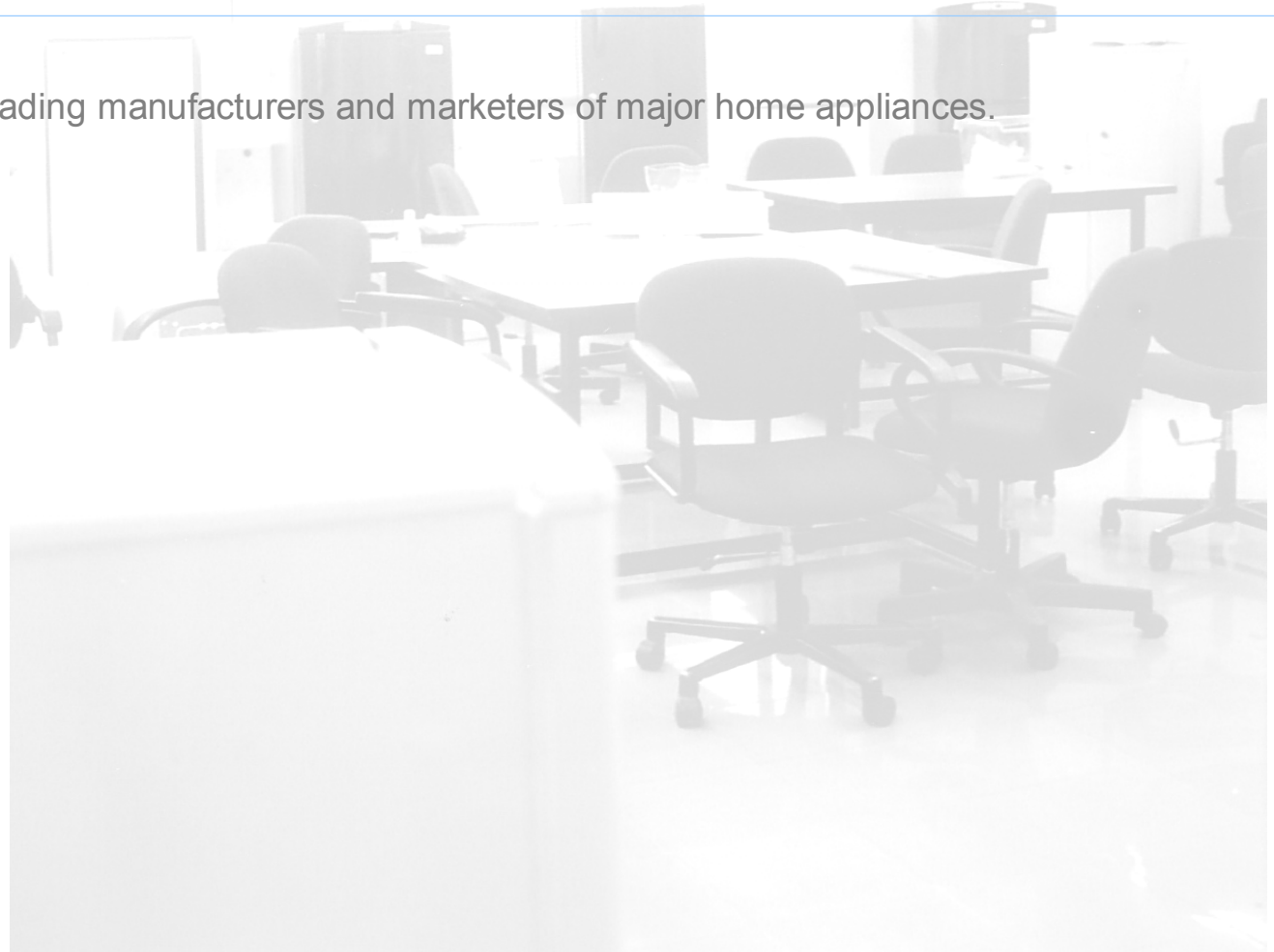

SUMMER TRAINING AT WHIRLPOOL OF INDIA LTD.

ABOUT WHIRLPOOL

Whirlpool Inc, US is one of the leading manufacturers and marketers of major home appliances.

PRINCIPAL BRANDS

Whirlpool
Bauknecht
Ignis
Kitchen Aid
Raybo

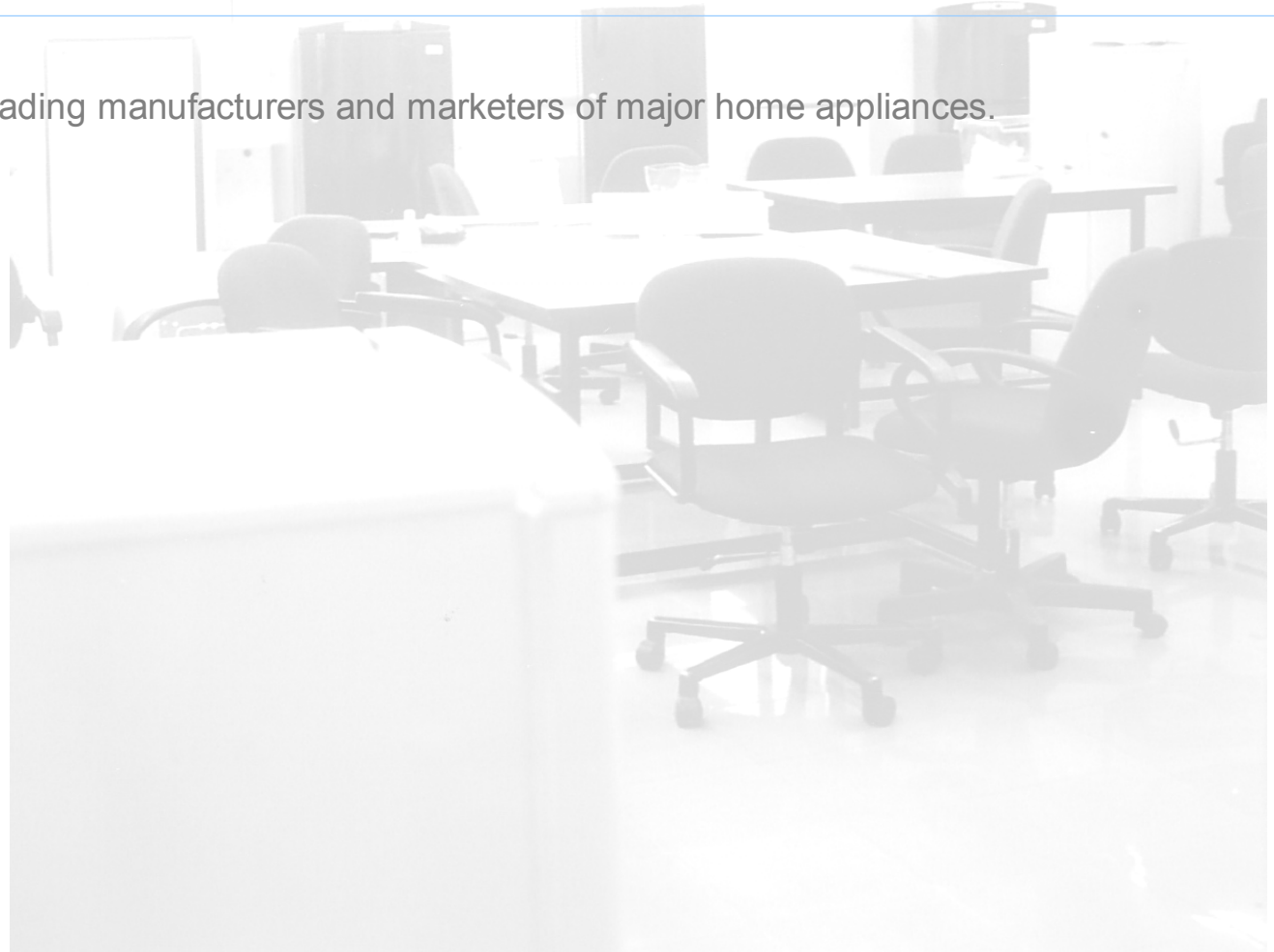

SUMMER TRAINING AT WHIRLPOOL OF INDIA LTD.

ABOUT WHIRLPOOL

Whirlpool Inc, US is one of the leading manufacturers and marketers of major home appliances.

PRINCIPAL BRANDS

Whirlpool
Bauknecht
Ignis
Kitchen Aid
Raybo

ZONES

Whirlpool North America
Whirlpool Europe
Whirlpool Latin America
Whirlpool Asia

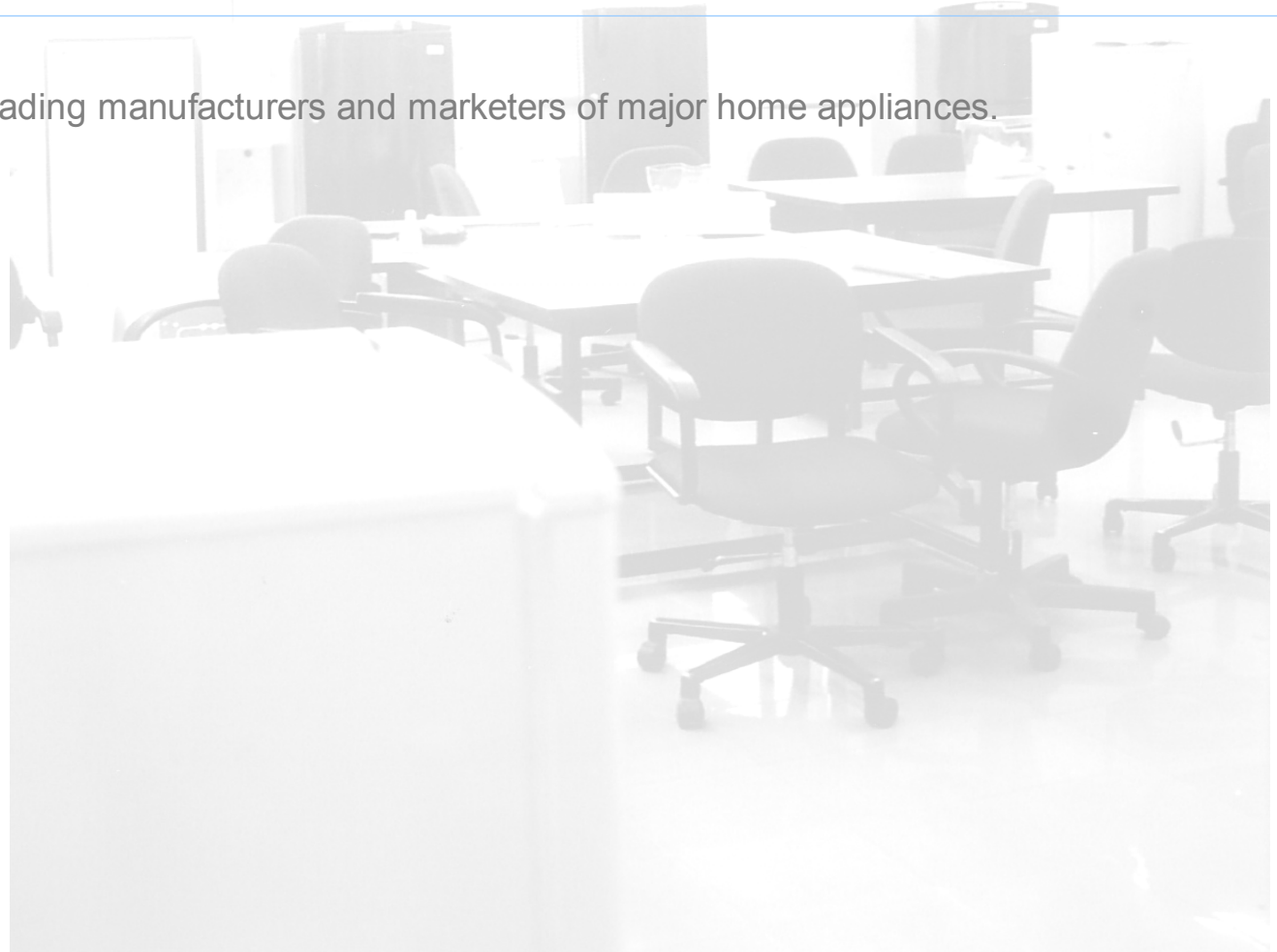

SUMMER TRAINING AT WHIRLPOOL OF INDIA LTD.

ABOUT WHIRLPOOL ASIA

Focused principally on two countries:

India

China

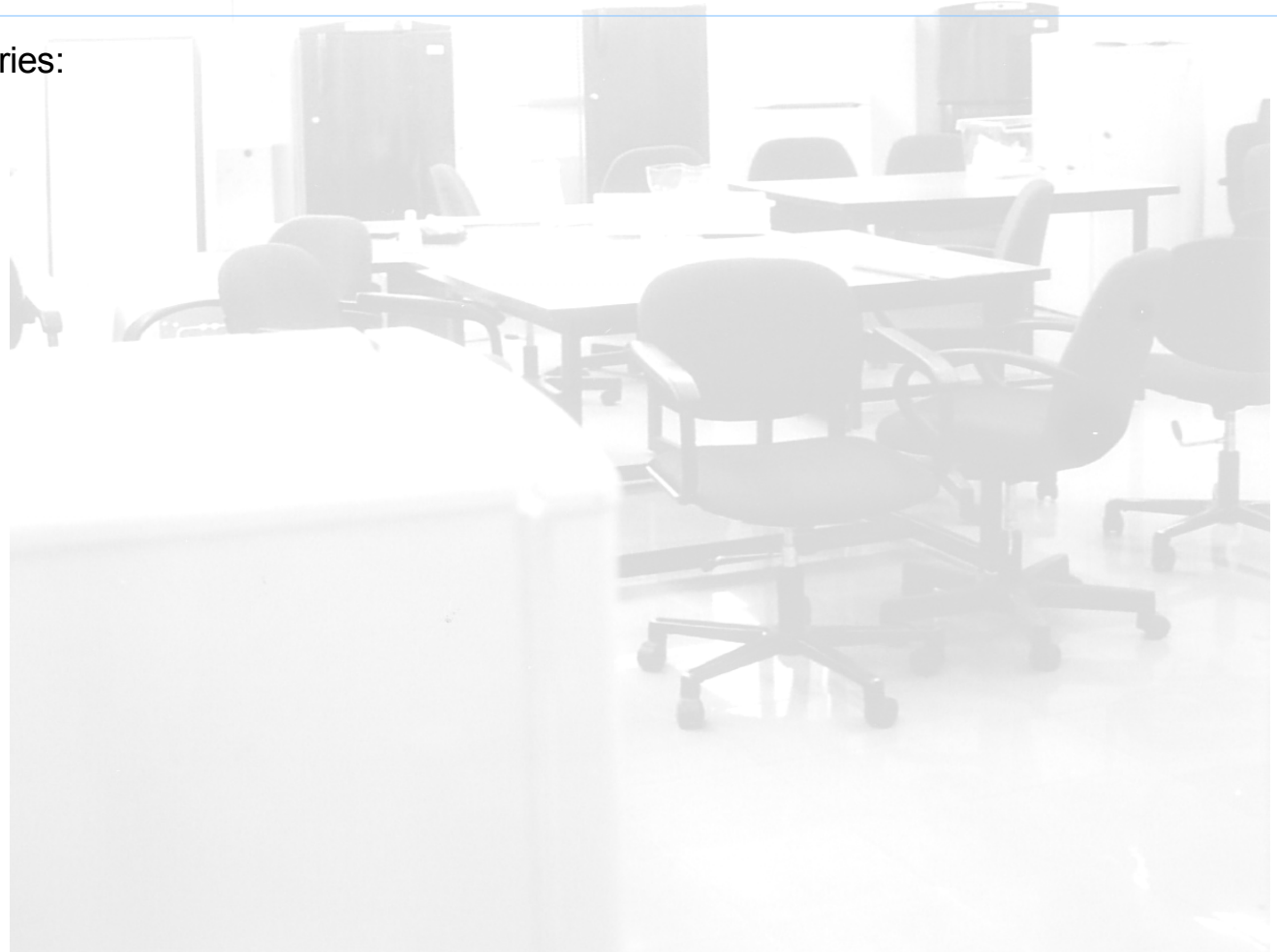

SUMMER TRAINING AT WHIRLPOOL OF INDIA LTD.

ABOUT WHIRLPOOL ASIA

Focused principally on two countries:

India

China

PRODUCTS

Automatic and semi-automatic washing machines, microwave ovens, refrigerators

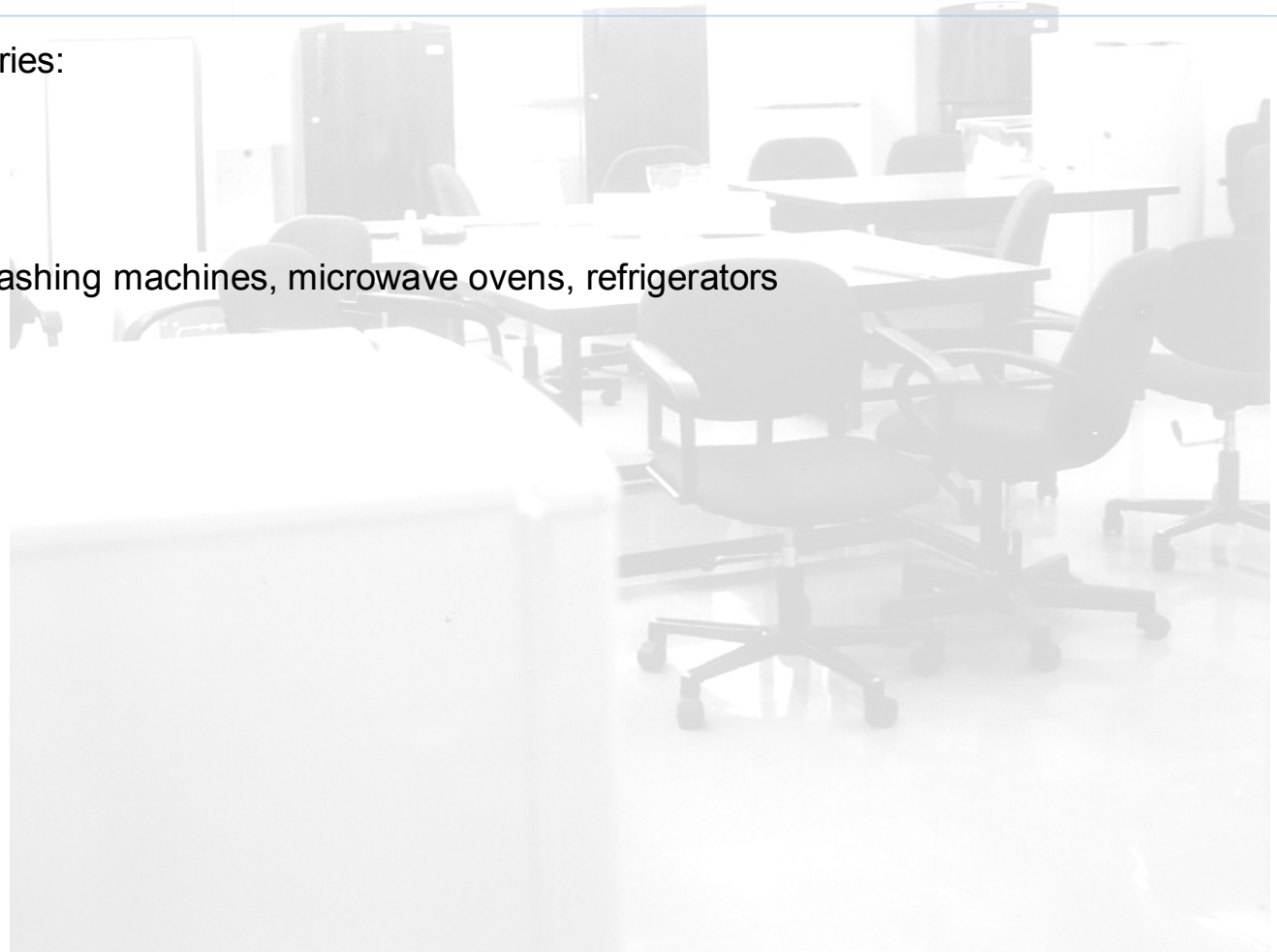

SUMMER TRAINING AT WHIRLPOOL OF INDIA LTD.

ABOUT WHIRLPOOL ASIA

Focused principally on two countries:

India

China

PRODUCTS

Automatic and semi-automatic washing machines, microwave ovens, refrigerators

MANUFACTURING FACILITIES

Faridabad, India (direct cool refrigerators)

Pondicherry, India (automatic and semi-automatic washing machines)

Pune (Ranjangaon) (no frost refrigerators)

Shanghai, China (automatic washing machines)

Shunde, China (microwave ovens)

ABOUT WHIRLPOOL ASIA

Focused principally on two countries:

India
China

PRODUCTS

Automatic and semi-automatic washing machines, microwave ovens, refrigerators

MANUFACTURING FACILITIES

Faridabad, India (direct cool refrigerators)
Pondicherry, India (automatic and semi-automatic washing machines)
Pune (Ranjangaon) (no frost refrigerators)

Shanghai, China (automatic washing machines)
Shunde, China (microwave ovens)

TECHNOLOGY CENTRES

Shanghai, China
Ranjangaon, India
Pondicherry, India

SUMMER TRAINING AT WHIRLPOOL OF INDIA LTD.

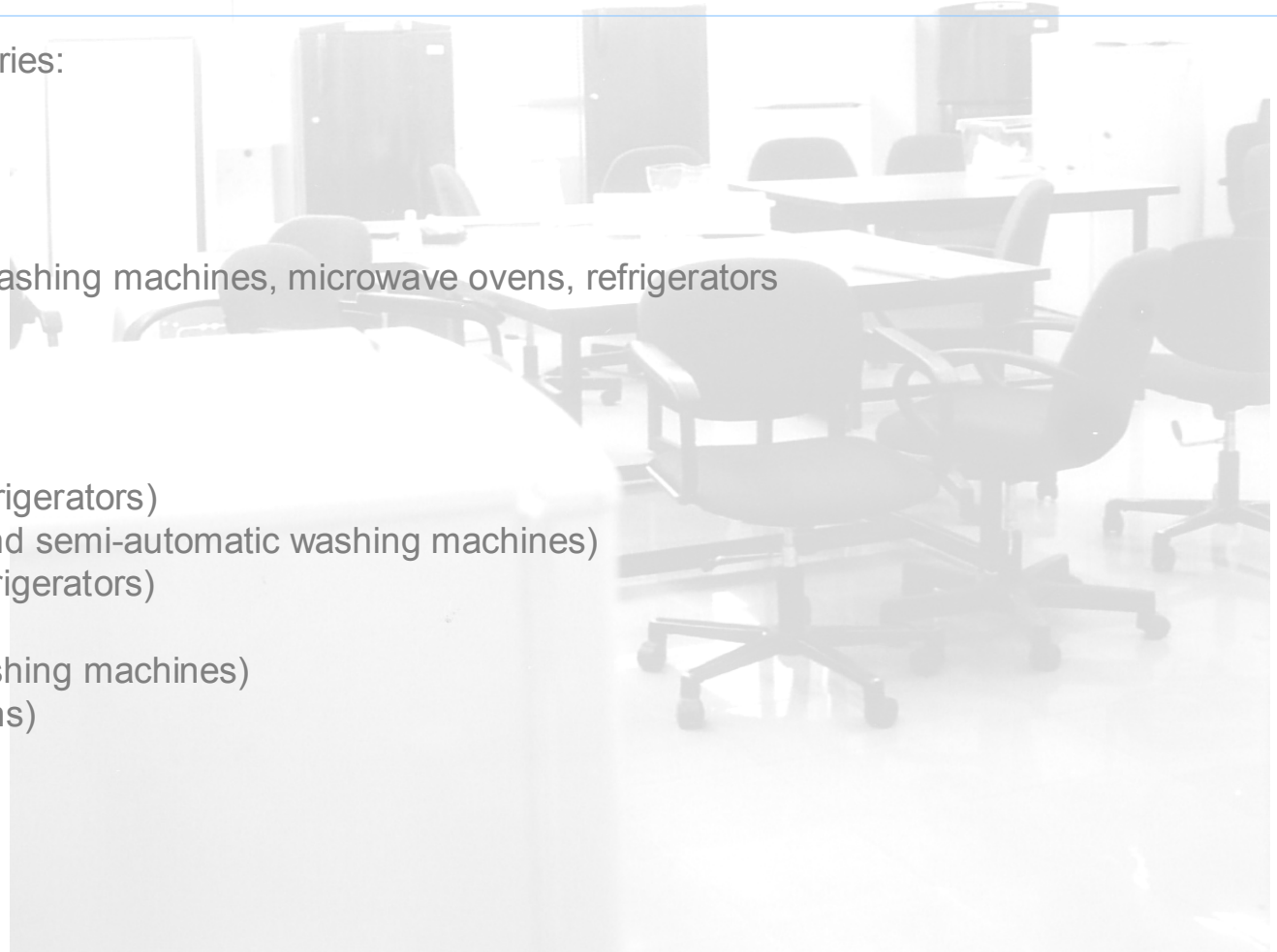

WHIRLPOOL OF INDIA LTD. (WIL)

Incorporated in 1960, Whirlpool of India –was formerly Kelvinator of India.

Now,the company has grown into a multi-unit company manufacturing refrigerators, deep-freezers, compressors, electrical grade laminations, cash registers, thermostats, microwave ovens and mopeds.

In 1994-95, it tied up with Whirlpool Corporation, US and the company acquired its present name.

WIL has its main plant at Faridabad in Haryana - to manufacture refrigerators and freezers.

The washing machine unit is located at Pondicherry.

WIL - RANJANGAON

In 1998, the company established another refrigeration plant at Ranjangaon near Pune.

This plant is also equipped with one of the Technology Centres of Whirlpool, more known as the Product Development Centre or PDC.

Here, Whirlpool's technology and procurement operations are organized by integrating the recent practices in

- product creation and development
- advance technology development
- manufacturing processes
- supply-base management
- globalization



SUMMER TRAINING AT WHIRLPOOL OF INDIA LTD.

WIL - RANJANGAON

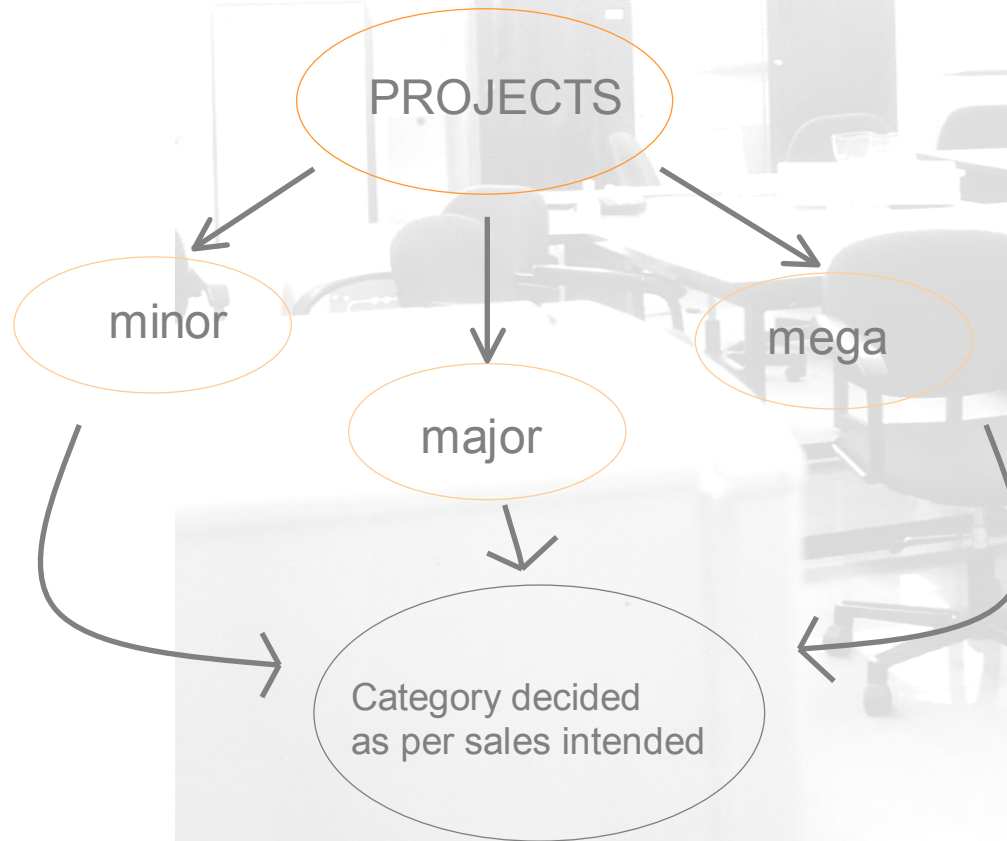

WIL - RANJANGAON

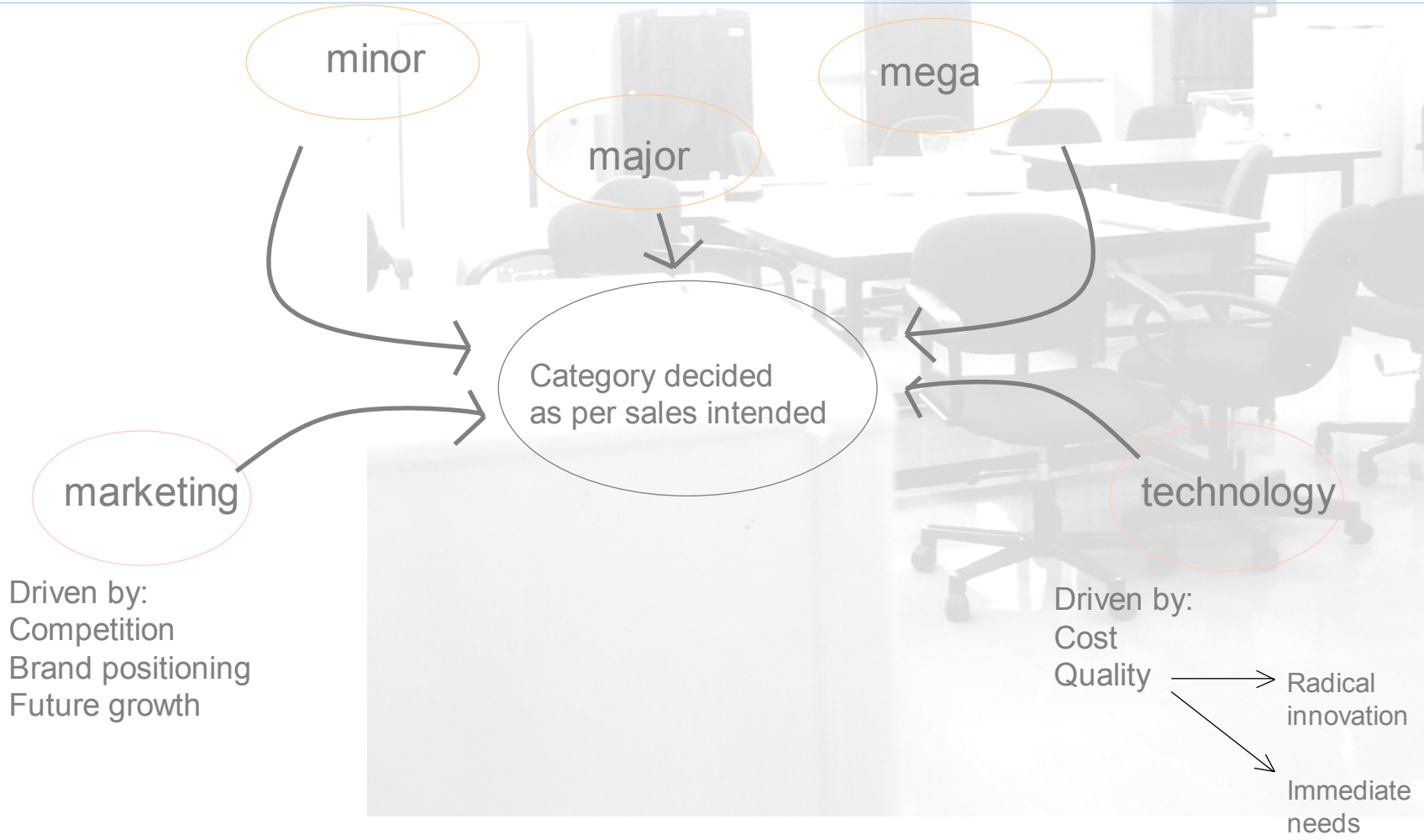

PRODUCT DEVELOPMENT

Product design and development is based on the principle of Robust Design with emphasis on

- customer focus
- translation of customer insights into design ideas, etc.
- rigorous design (FMEAs, etc.)

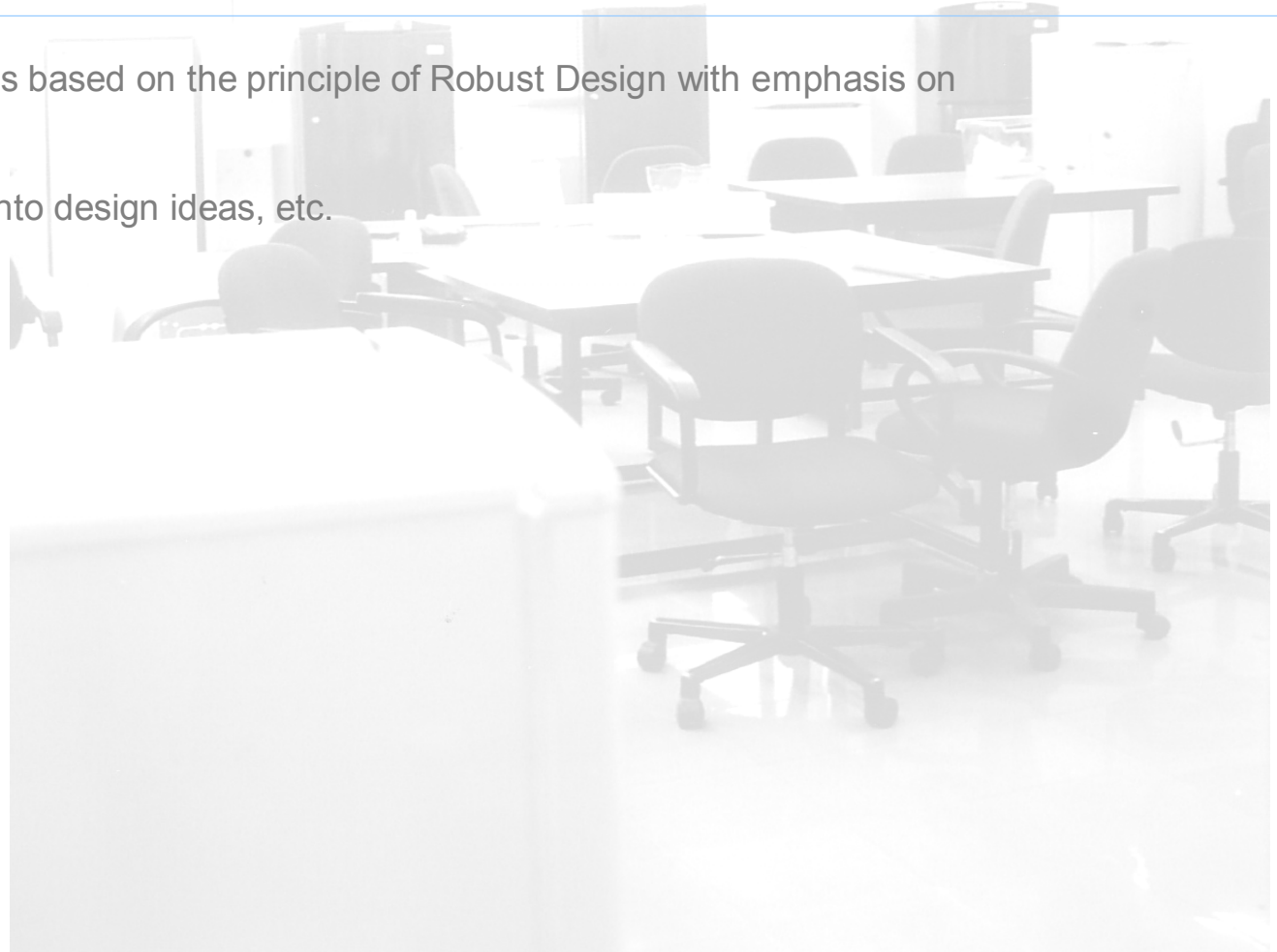

SUMMER TRAINING AT WHIRLPOOL OF INDIA LTD.

DESIGN METHODOLOGY

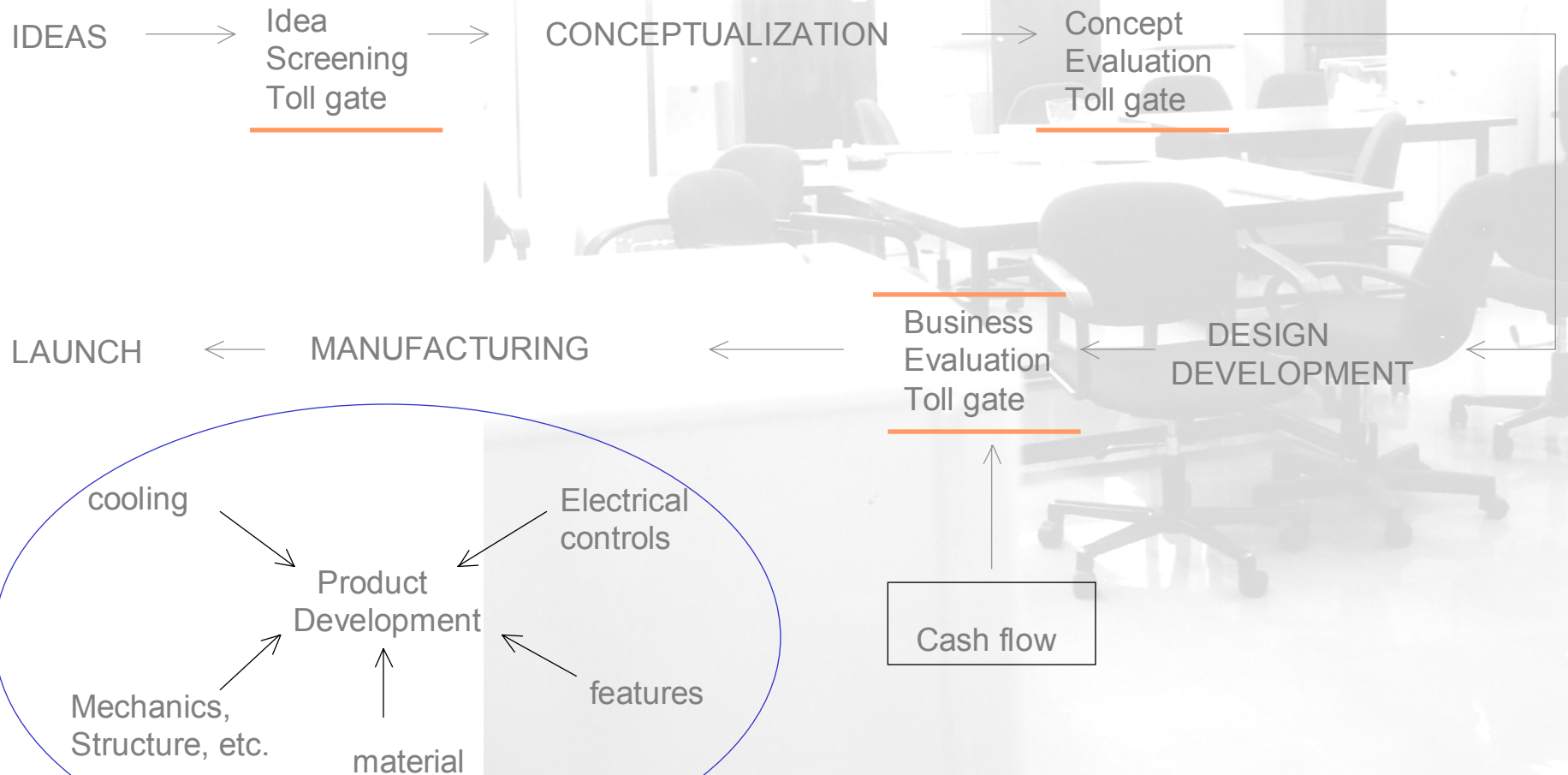

PRODUCT DEVELOPMENT CENTRE

Material testing lab
Structural testing lab
Sound/vibration testing lab
Performance lab
Electrical lab
Design-product features

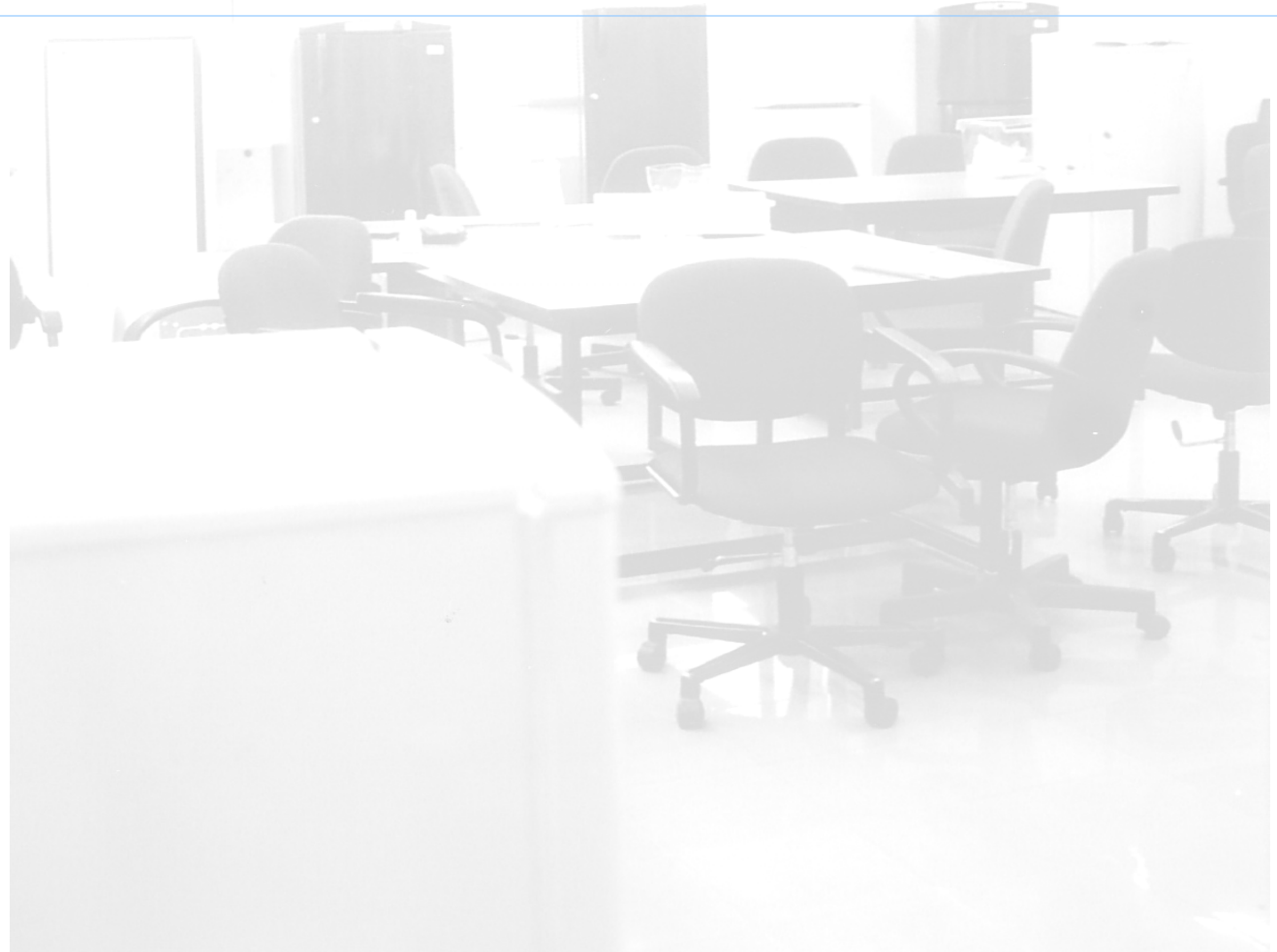

SUMMER TRAINING AT WHIRLPOOL OF INDIA LTD.

ASSEMBLY LINE

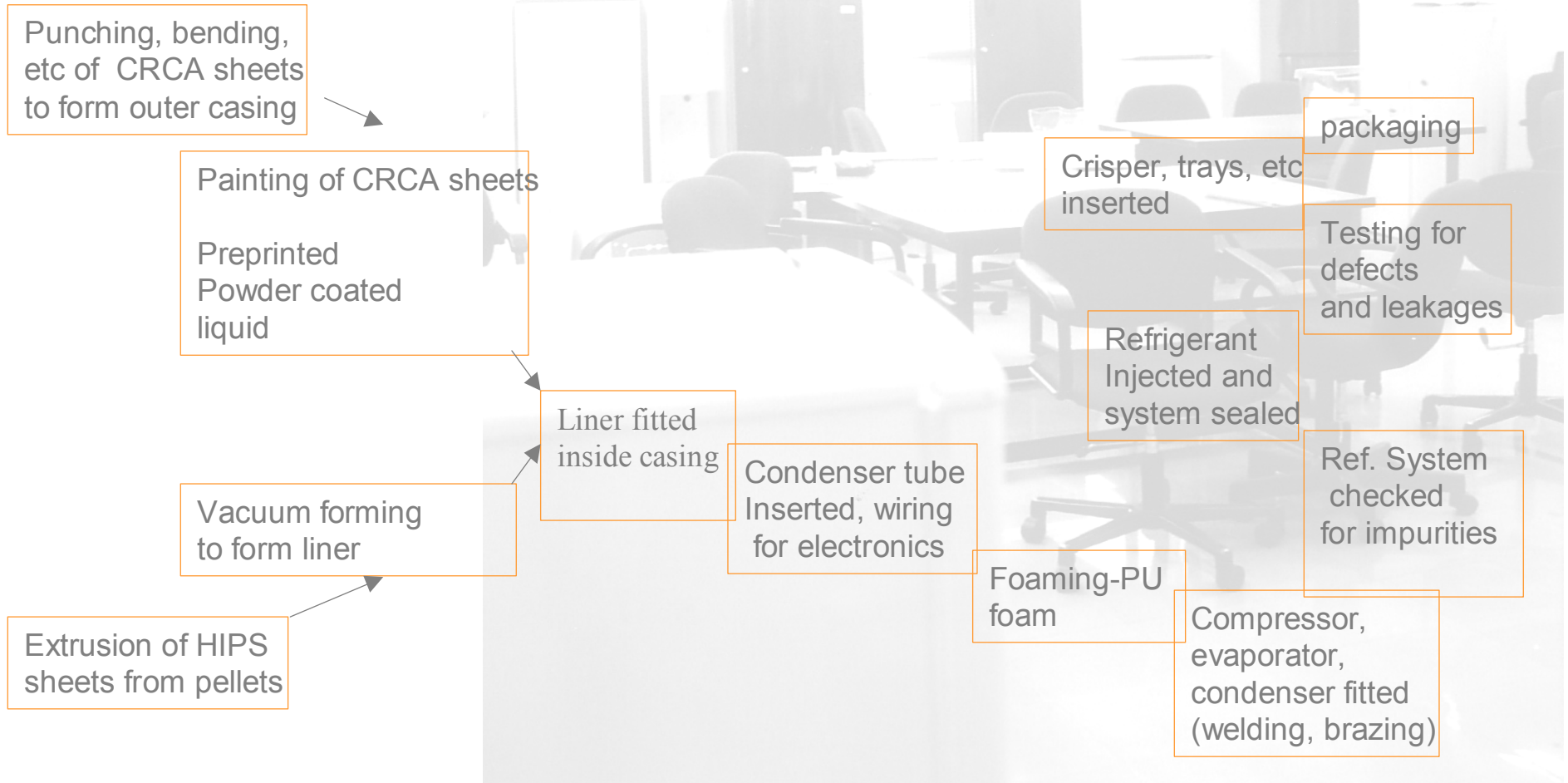

PROJECT WORK

Product familiarization-aesthetics, product detailing, etc
Understanding refrigeration concepts
Understanding materials and processes on the assembly line
Understanding cost and manufacturing constraints
Design methodology and team work
Communication techniques

METHOD

User survey

Documentation of different products kept in the refrigerator

Insights

Ideation – developing concepts for

- aesthetics for the diffuser
- crisper separator (focus on saving cost and material)
- storage concepts for the refrigerator (focus on usability and flexibility of use)
- innovative concepts for refrigerators
- idea bank – futuristic concepts for refrigerators

PRODUCT FAMILIARISATION – STUDY OF DETAILS

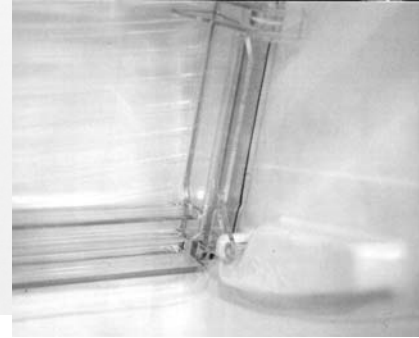
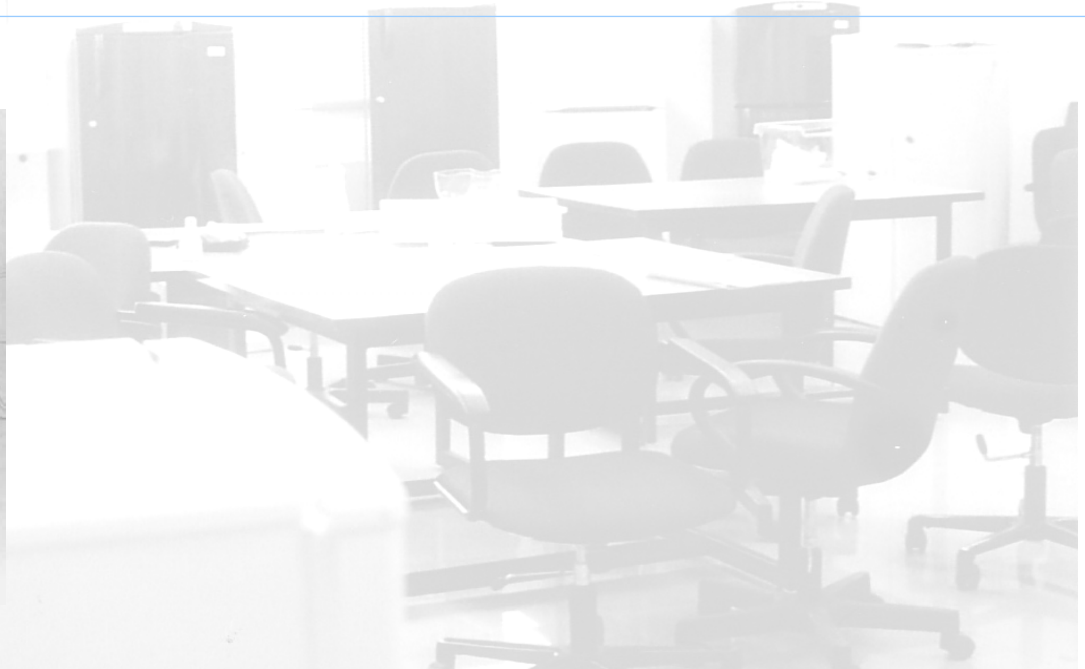
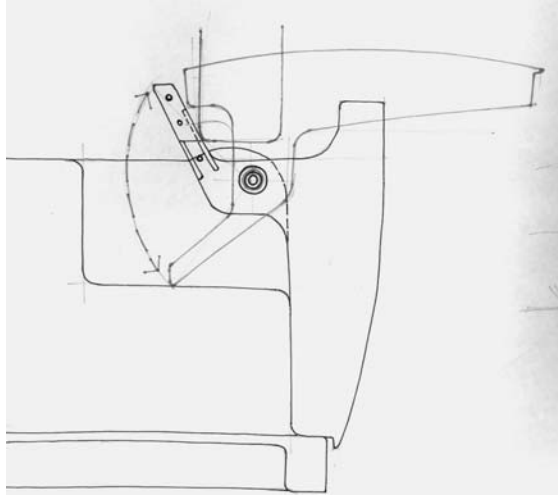

SUMMER TRAINING AT WHIRLPOOL OF INDIA LTD.

USER SURVEY

SR NO.	MODEL	NO. OF USERS	COST (in Rs.)	NOTES	ITEMS STORED IN REFRIGERATOR AREA	ITEMS STORED IN CRISPER
1	videocon (3 door)	2 no.s	17000	prefers keeping stuff sealed in either containers or plastic bags, buys veg. once a week	steel patilas, tupperware containers, pet bottles, shrikhand boxes, plastic packs	vegetables, leafy vegetables, water bottles
2	L.G. Green life 220 lit. (No Frost)	3 no.s (but guests come very frequently)	13000	buys veg. twice a week, 2/3 liters of water consumed per day	steel patilas (with and without lid), milk vessel, leafy veg., bottles	vegetables
3	Godrej 290 lit. (Direct cool)	4 no.s		buys vegetable once a week	vessels containing milk, cooked veg., etc. fruits (apple, papaya, mangle, watermelon), tupperware (pulses, dryfruits, maida, etc)	vegetables
4	Godrej cold gold (8 yrs. old)	2 adults, 1 two yr. old child		buys veg. twice a week, 1 nos. 2 litre water bottle enough-bottle space wasted (filled with other items like masala pack, butter pack, sauce bottle, papad pack)	steel vessels containing rice, curry, veg. curds, milk vessel (1 1/2 lt.)	vegetables

5	BPL -F332VX 320 lit. (no frost) (3 yrs. Old)	3 adults, 1 one year old child	22,000	consume around 3 lt. of water daily	milk cooker (1 lt. milk), rice cooler, salad, curry. Curds	vegetables, fruits
6	Godrej 160 lt. (Direct cool) (15 yrs. Old)	4 no.s	6000	don't drink cold water, buy vegetables once or twice a week, prefer storing in plastic bags	steel vessels containing, curry, veg. curds, butter milk, frequently reqd. vegetables like tomatoes, chili, dhaniya, leafy vegetables (in plastic wraps)	vegetables(crisper not very fondly used because of lack of ease in accessibility)

DIFFUSER

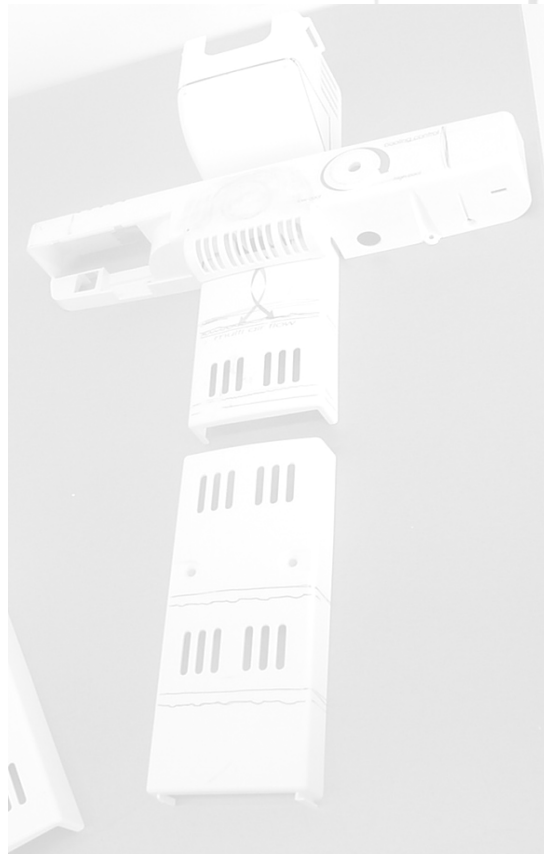

SUMMER TRAINING AT WHIRLPOOL OF INDIA LTD.

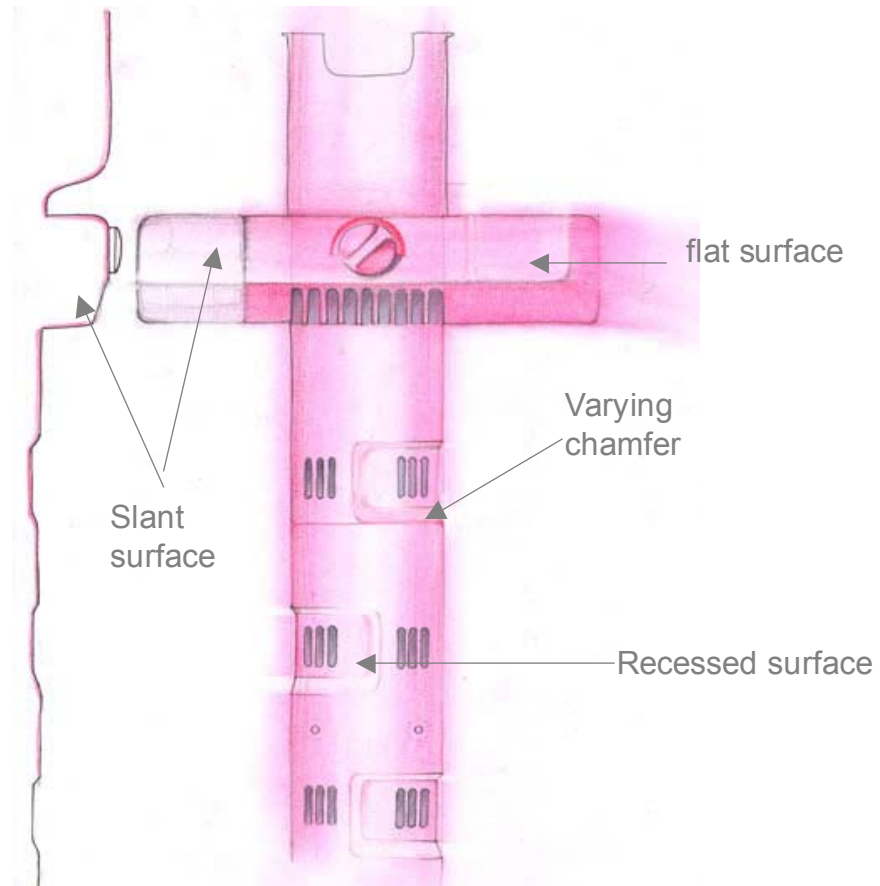
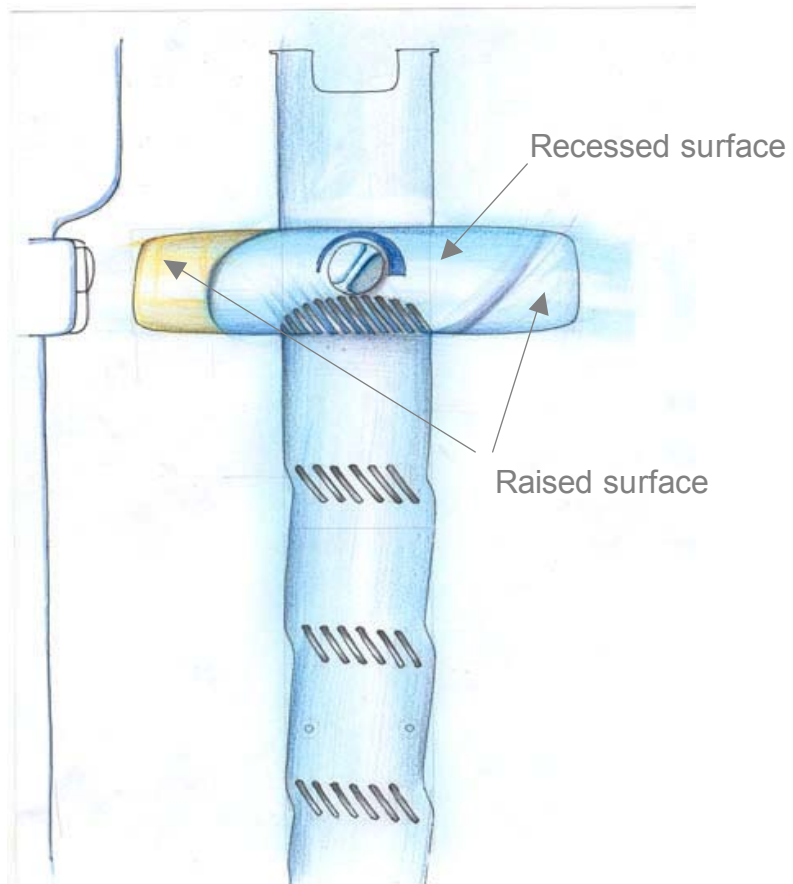

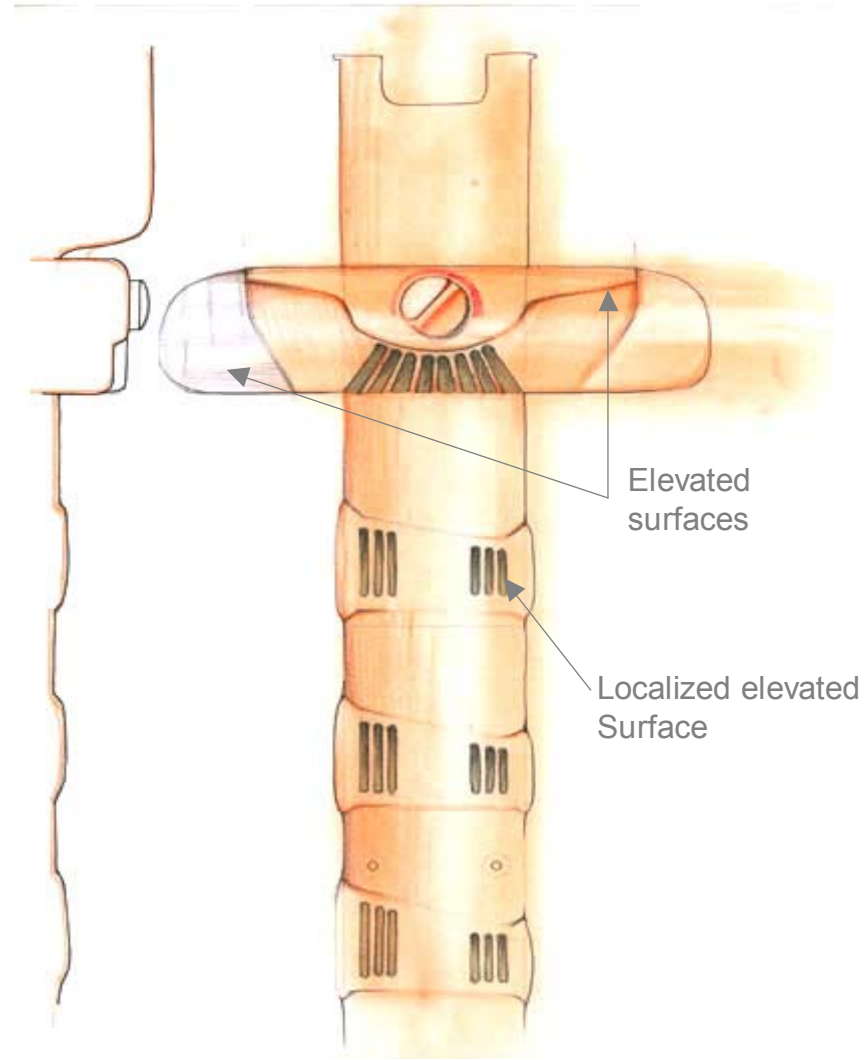
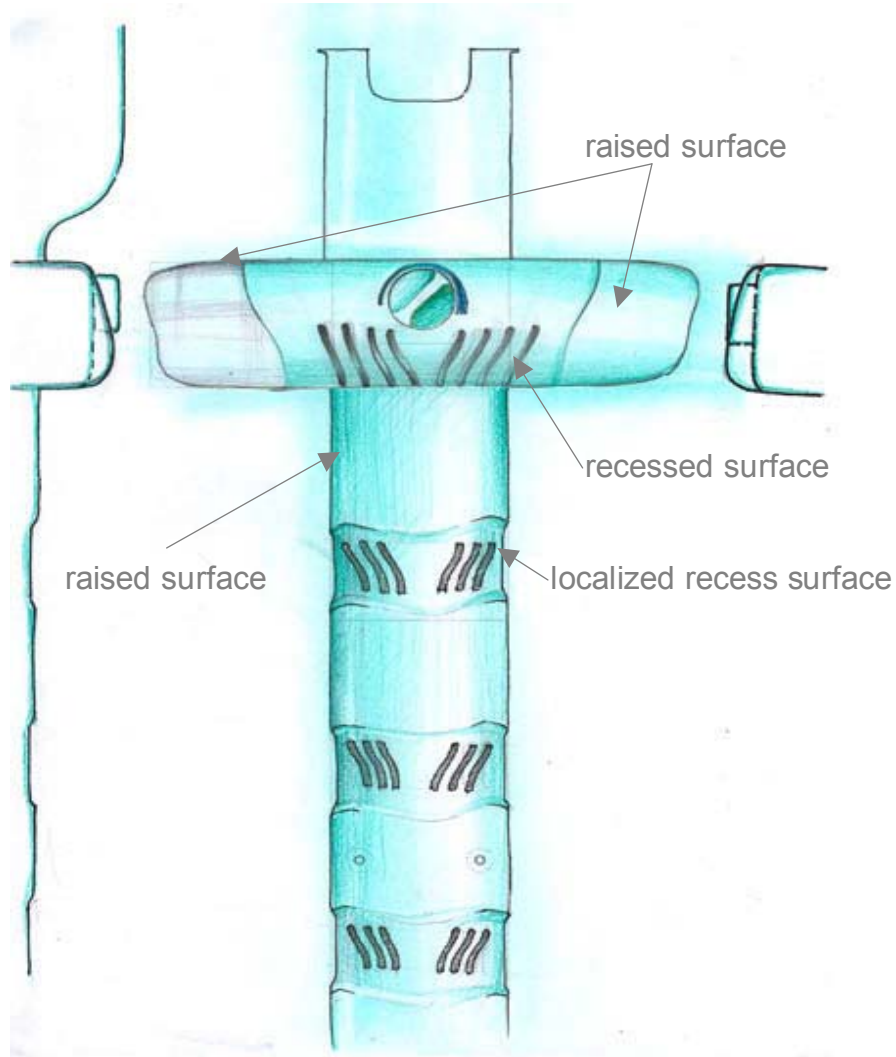

CRISPER SEPERATOR

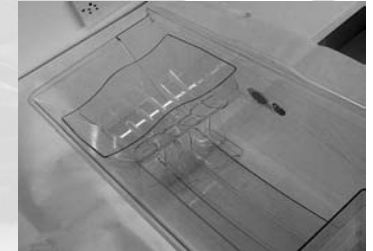
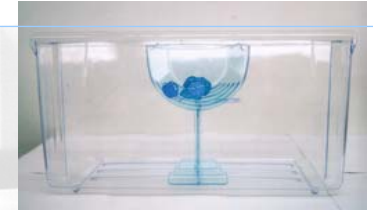
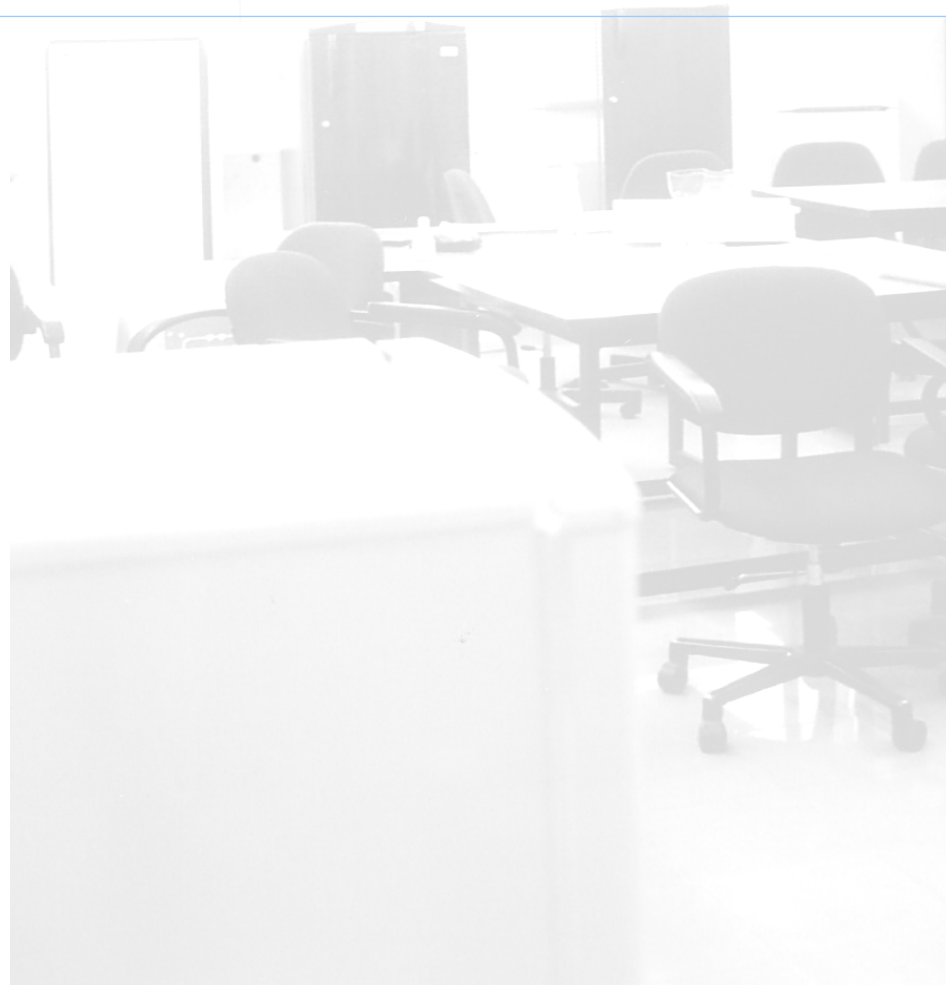

SUMMER TRAINING AT WHIRLPOOL OF INDIA LTD.

CRISPER SEPERATOR

In this concept, the crisper separator can be shifted to one side of the vegetable container.

Customer benefit:

When the separator is not required, it can be aligned to one side of the crisper without wasting any storage space.

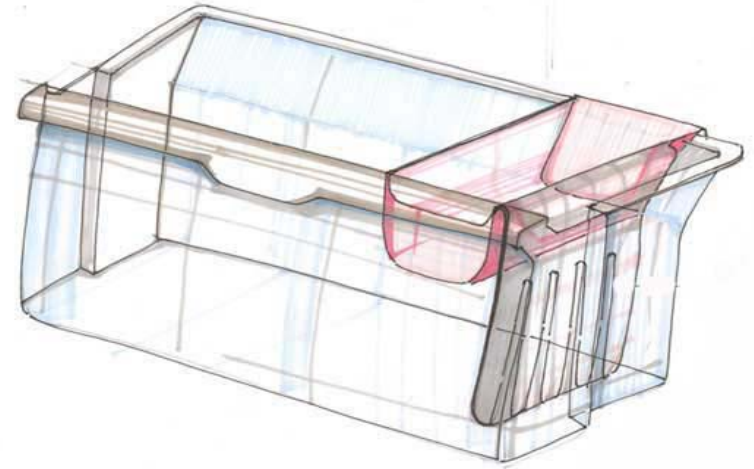
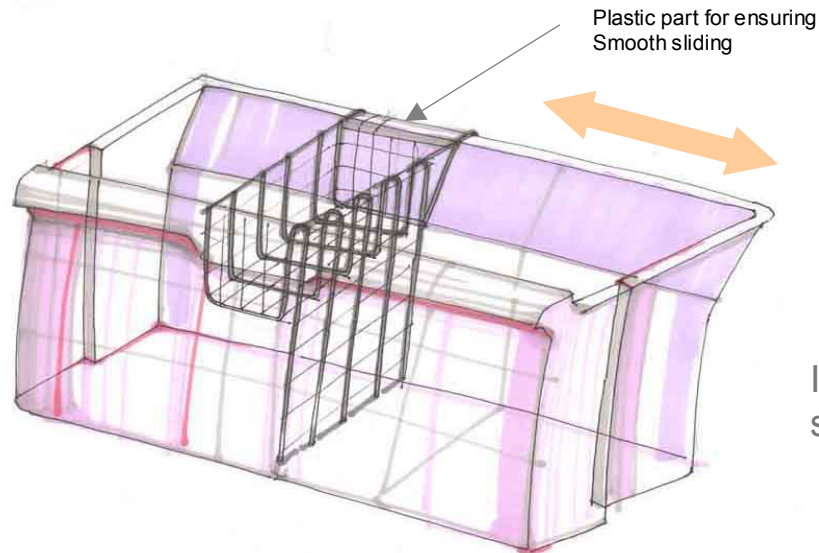

In this concept, rods and wire mesh is used to save material and cost.

Vegetable container

separator

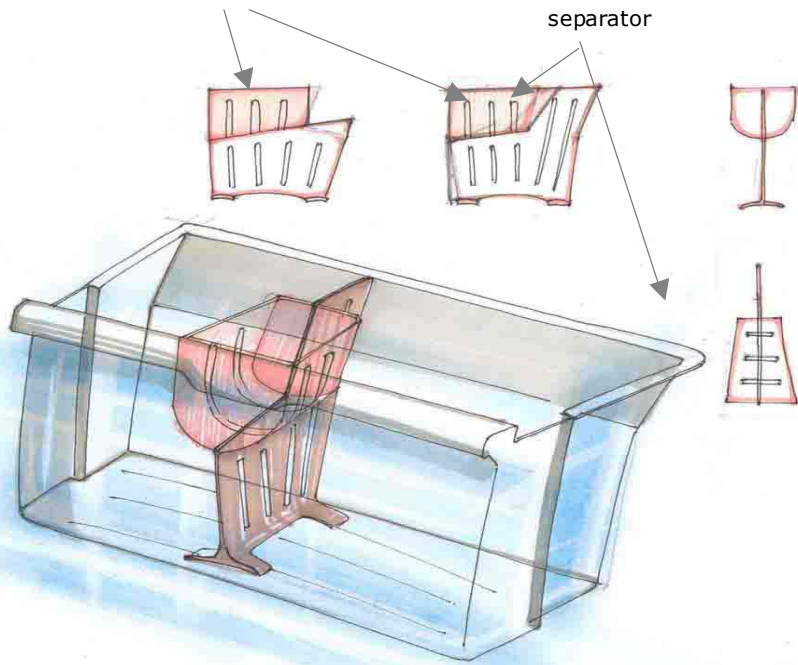

In this concept, the volume of the complementary vegetable container reduced

In this concept the surfaces of the container which are along the edges of the crisper are reduced to a thin collar. This can be done as the walls of the crisper itself would prevent bigger vegetables like tomatoes etc. from falling out of the container. The thin collar is retained to contain small items like chillies... it also acts as a rib by giving structural stability to the curved surface.

thin collar

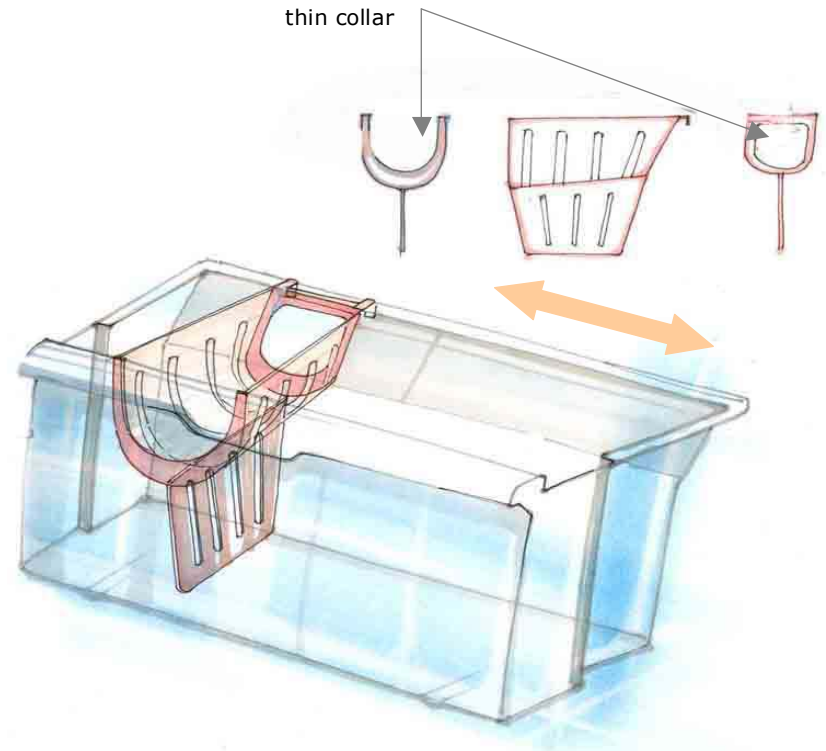

SUMMER TRAINING AT WHIRLPOOL OF INDIA LTD.

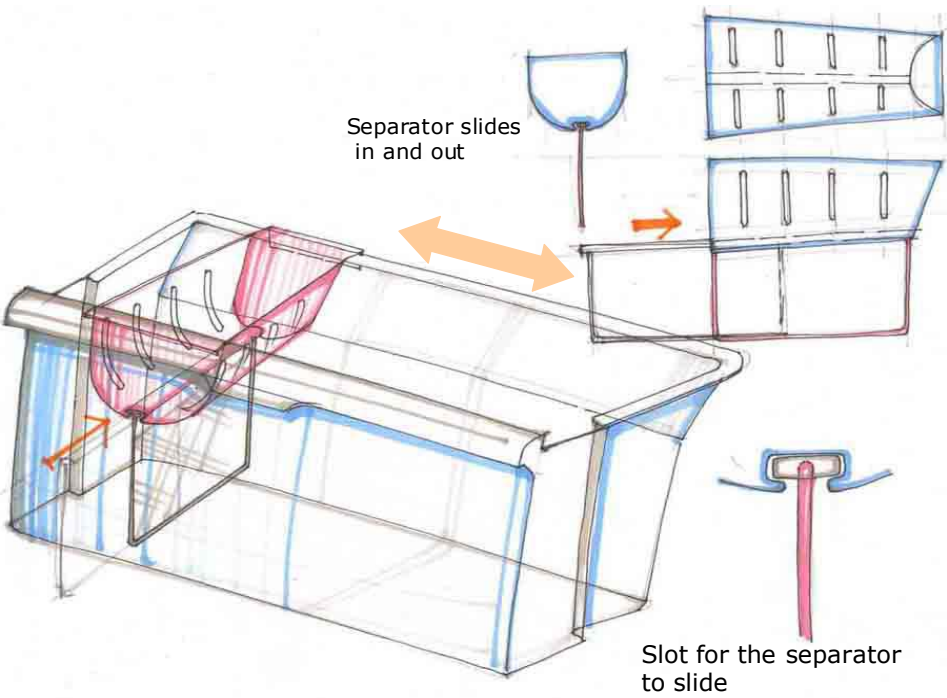

Here, the vegetable container and the separator are separate parts... the container is in plastic and the separator is made of a net like surface bound by rods.

as separator and container are different parts, for low end models only container can be provided

Customer benefit:
Whenever required the separator can be slid into the in built track in the plastic container...if not required, it can be detached from the same, thus providing flexibility of use.

In most cases, space near the junctions of edges and Corners becomes redundant as it cannot accommodate anything. So here, the edges and corners are rounded off. This also saves material.

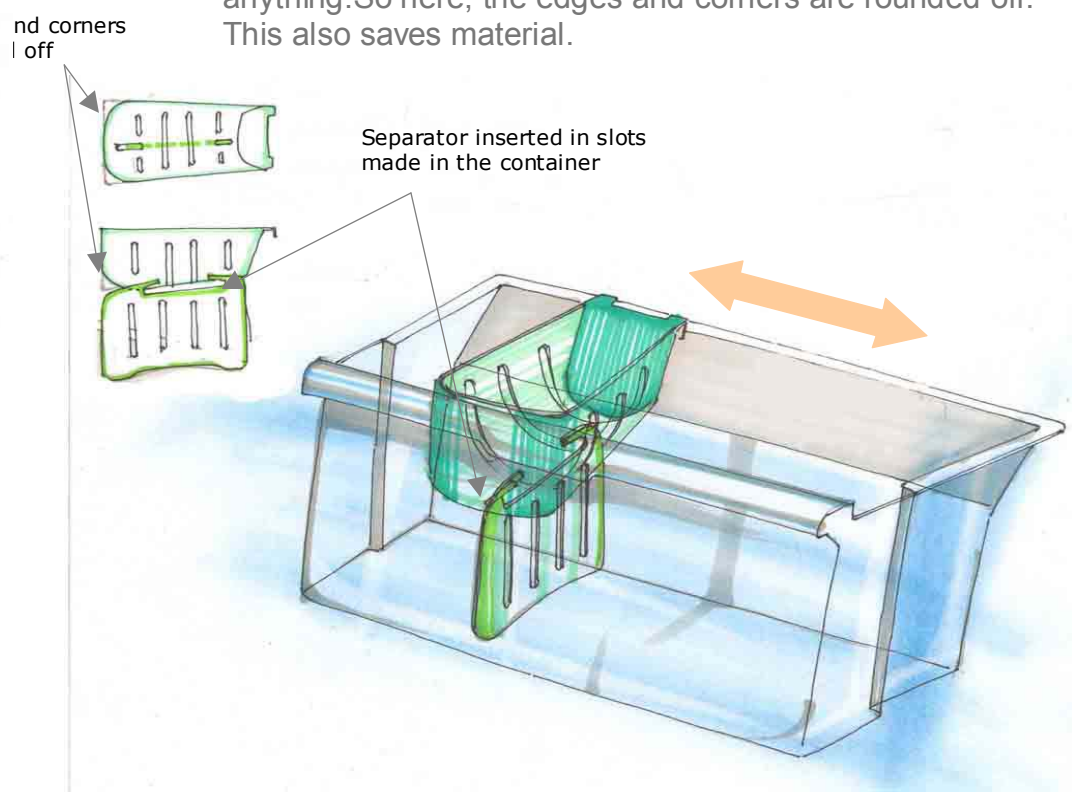

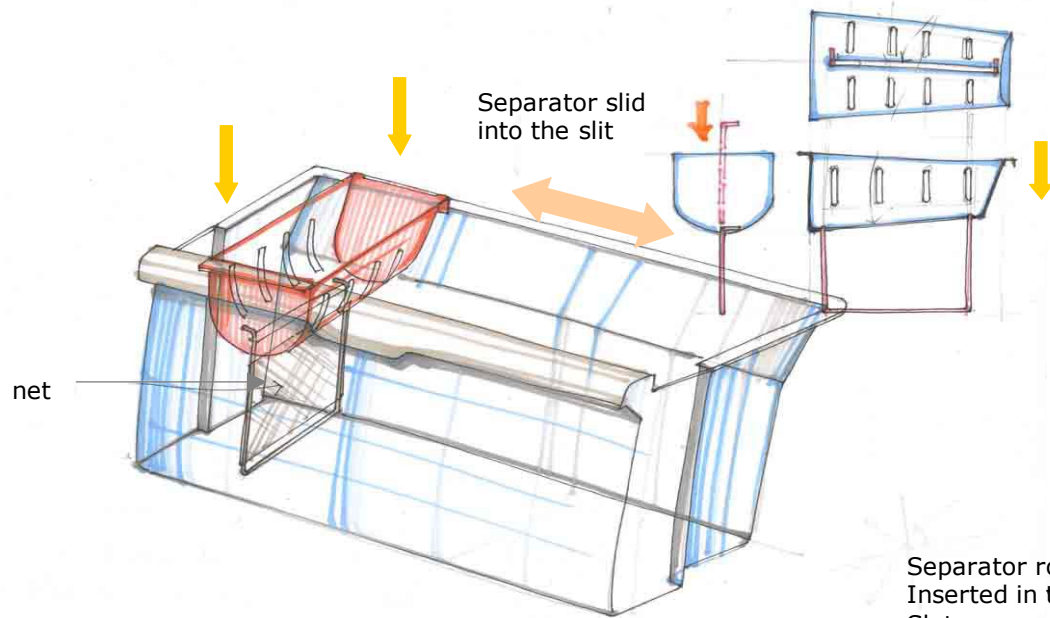

This is a variation of the previous concept . Here, the separator is attached to the container by inserting the rods into a continuous slit made in the surface of the container.

Customer benefit: Flexibility of use as in the previous case.

This is a variation of the previous concept . Here, the separator is attached to the container by inserting the rods into slots made in the surfaces of the container.

Customer benefit: Flexibility of use as in the previous case.

Separator rods inserted in the Slots.

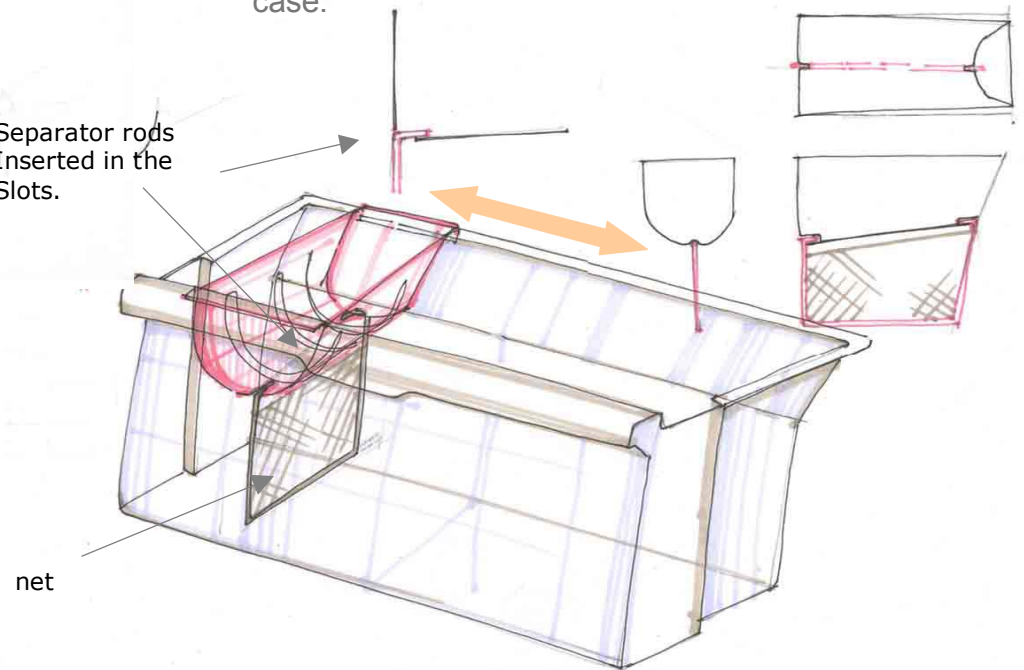

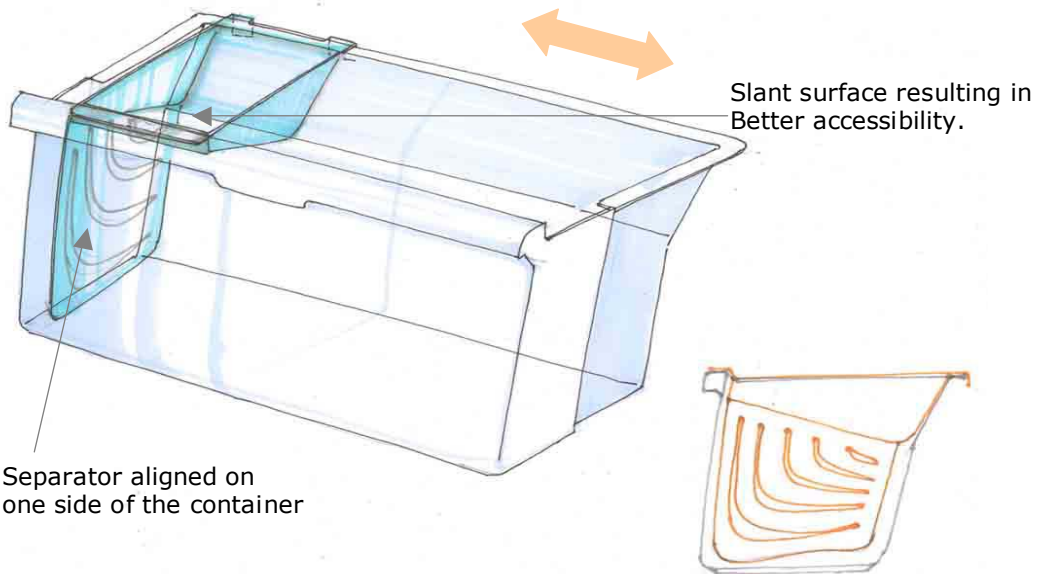

Separator aligned on one side of the container

Here, surface area of the container is reduced by eliminating one vertical surface...resulting in a slant bottom surface as seen below.

Customer benefit: better accessibility to the container.

Here, the continuous surface of plastic acts as a separator. At the same time, the folds of the surface also give a provision to store small things like chillies, dhaniya, lemon, etc.

This saves on space and material.

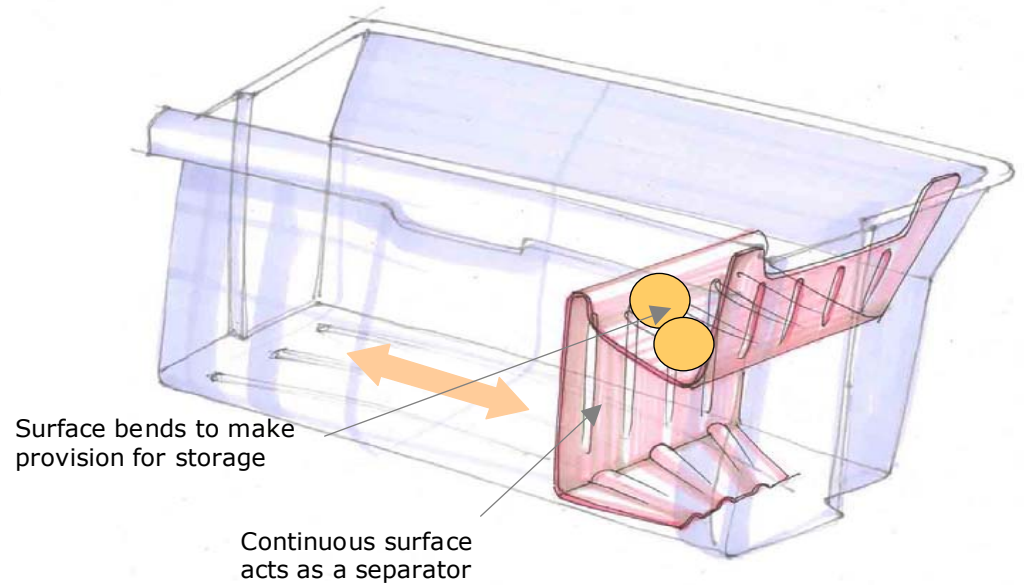

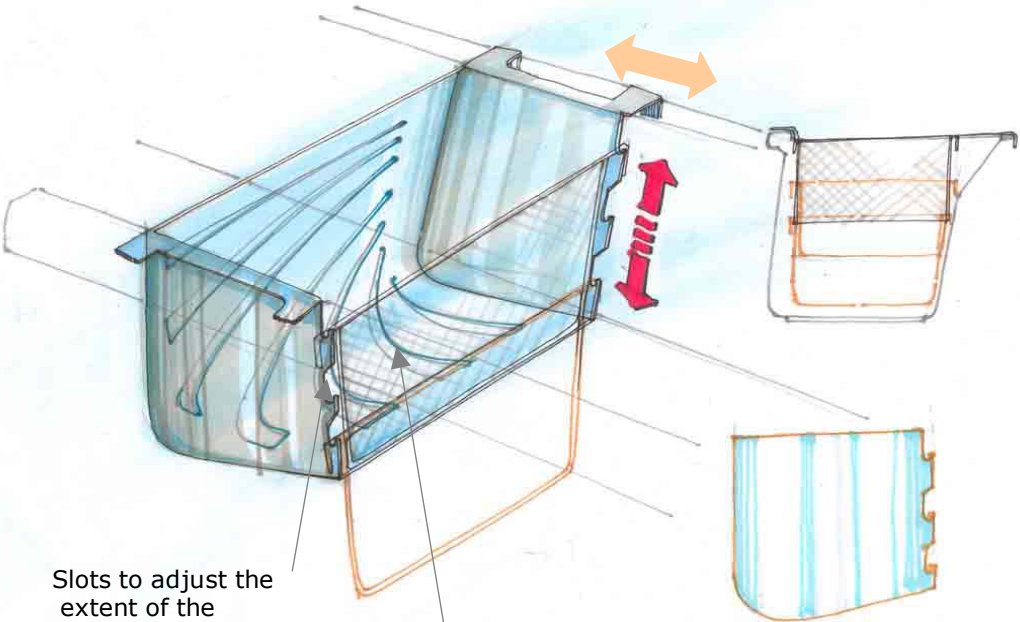

Slots to adjust the extent of the separator and the container wall

Inclination of surface ensures storage even when netted surface is pushed down

This is a variation of the previous concept . Here, Slots are given at various heights for adjusting the extent of the separator and the wall of the container.

Customer benefit: adjustability

In this concept, one surface of the container is hinged to be used as a separator if required.

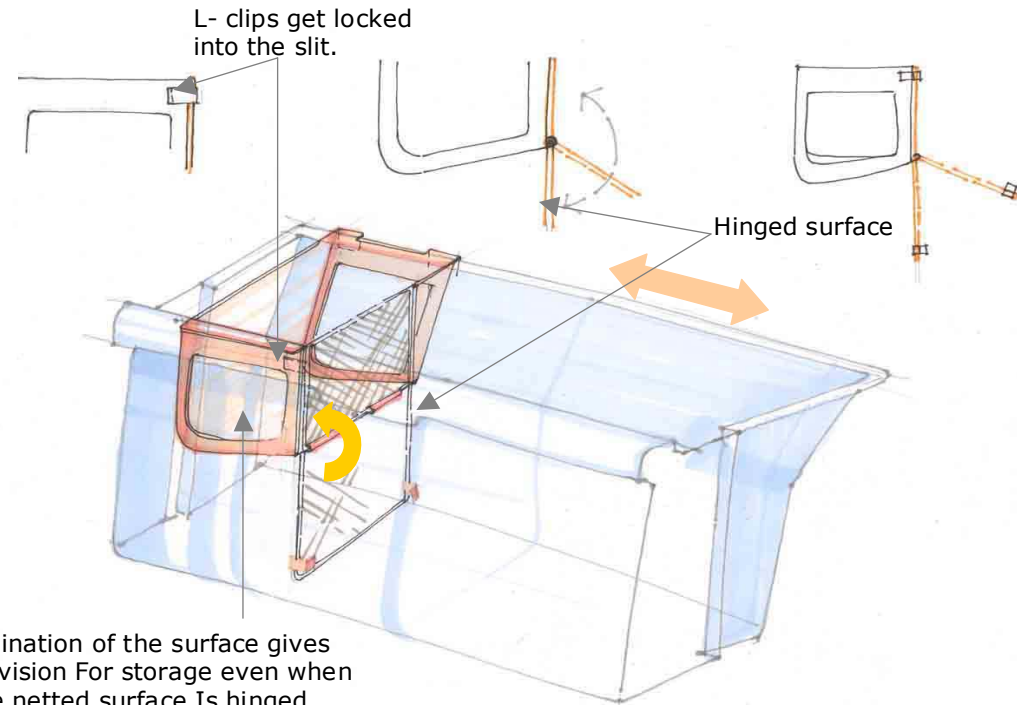

L- clips get locked into the slit.

Hinged surface

Inclination of the surface gives Provision For storage even when the netted surface is hinged downward

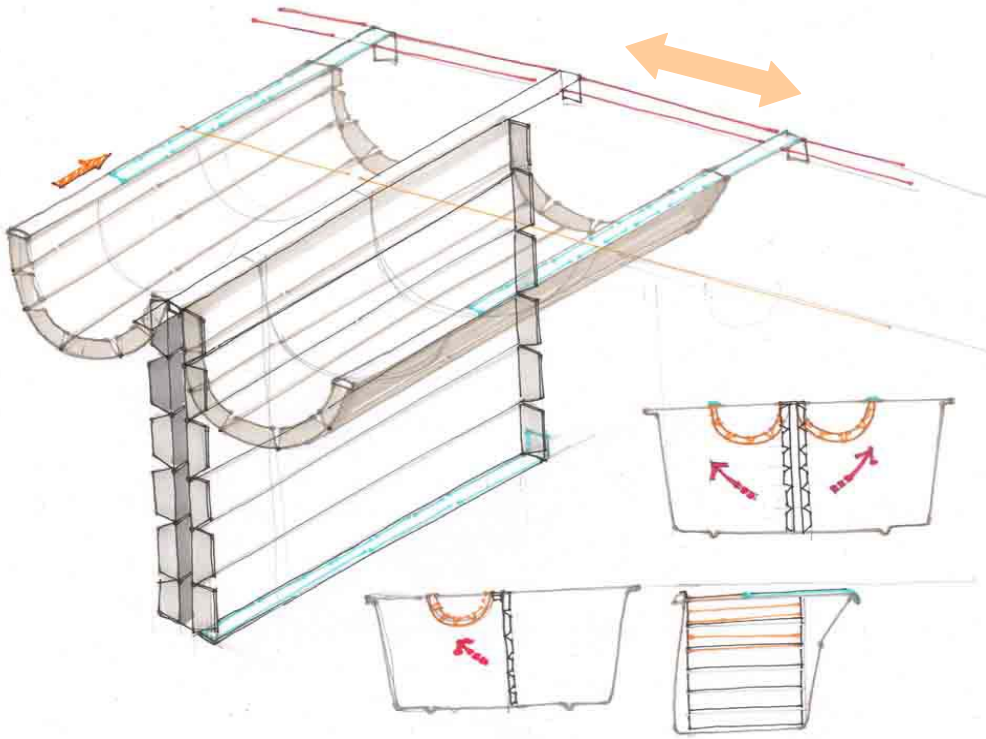

Here, a surface with linear grooves is used to achieve flexibility

Customer benefit:

If required the user can use the assembly as

- only separator
- separator and container
- only containers

as seen above thus giving flexibility of use.

Here the idea is to achieve collapsibility in the container. This is achieved by way of bellowed surface as seen below.

Customer benefit:

The container can be collapsed when not required so that it does not take up space.

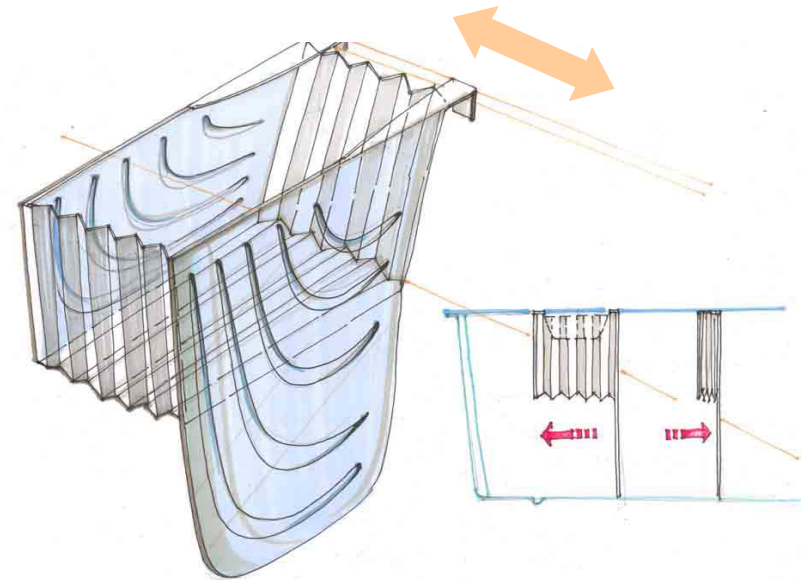

Here, a net bag is used to function as a separator as well as a container.

Customer benefit:

The bag can be easily taken out of the crisper and kept out. The user can actually buy vegetables in the same bag and keep it as it is in the crisper... ..this would save sorting time and trouble to the user

Net bag can also act as shopping bag

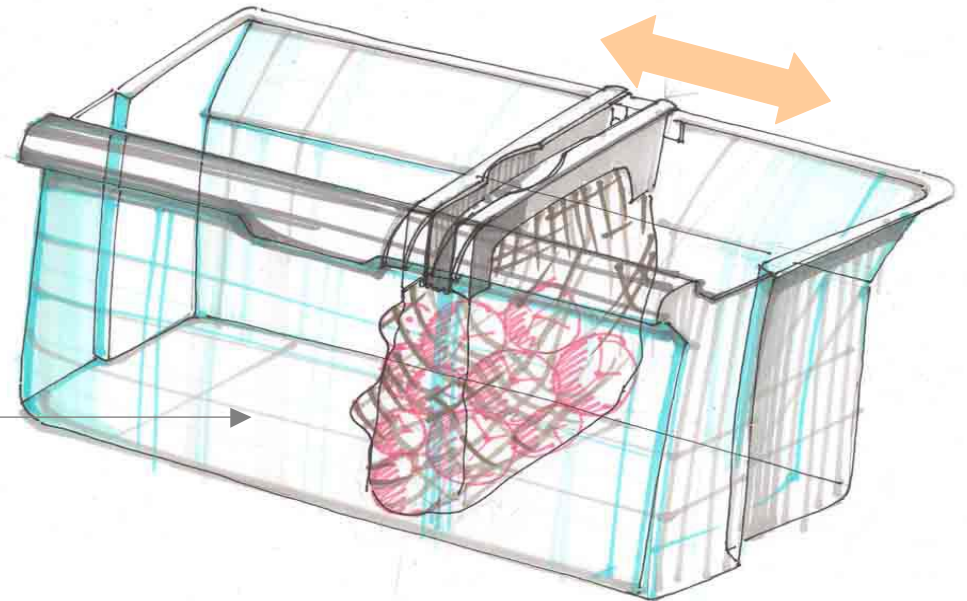

STORAGE CONCEPTS FOR THE REFRIGERATOR

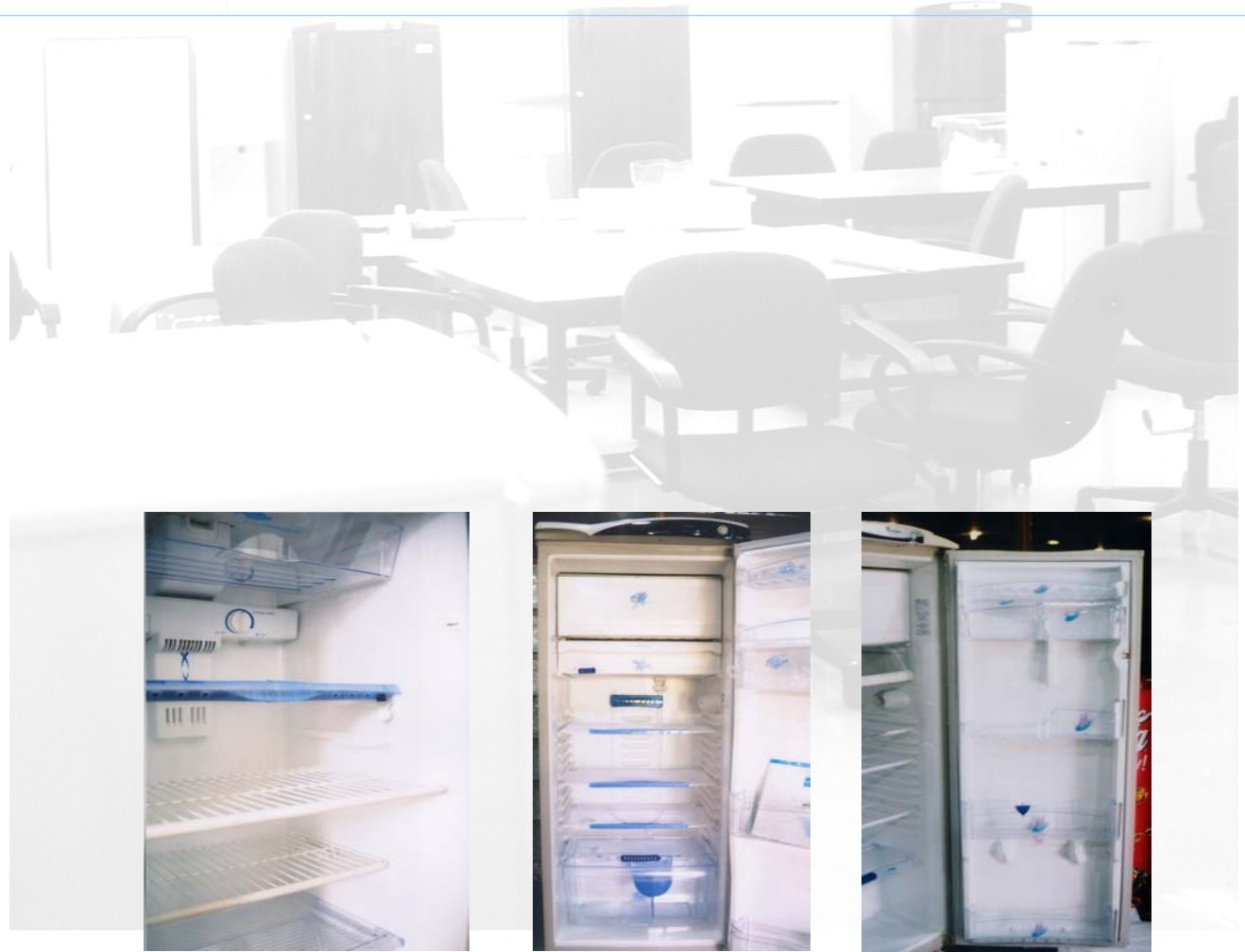

SUMMER TRAINING AT WHIRLPOOL OF INDIA LTD.

BOTTLE STORAGE

Here, the idea is to have a collapsible bottle storage container which when required, can store up to 1-4 bottles.... And when not required, can collapse along a plane thereby not taking up any extra space.

Customer benefit: flexibility of use and collapsibility

The size of the arrangement allows horizontal as well as vertical stacking

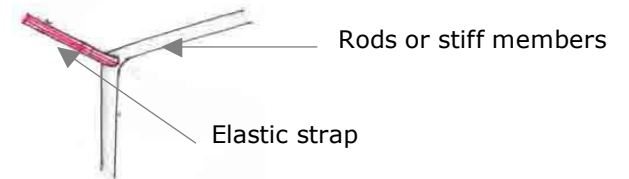
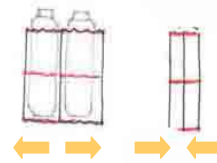
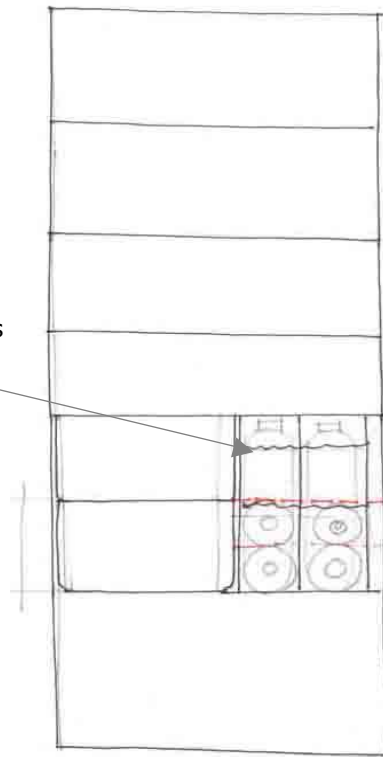

Rods or stiff members

Elastic strap

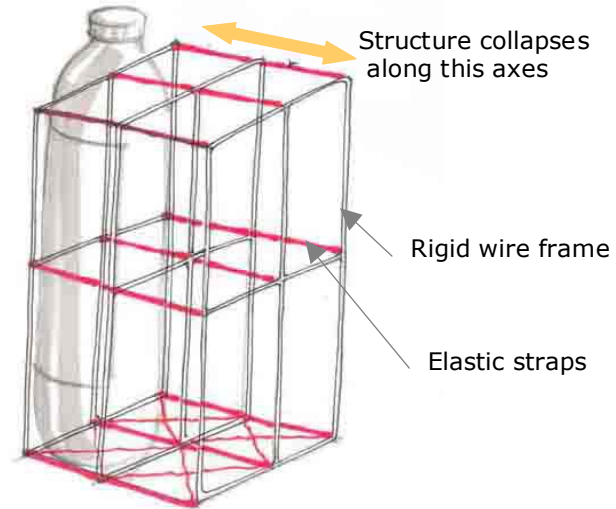

Structure collapses along this axes

Rigid wire frame

Elastic straps

It is found that the chiller space is not very useful for storage because of its shape and size. On the other hand, there is more storage space required for storing bottles, small items like dry fruits, chilies, chocolates, toffees, etc.

Here, the idea is to use the chiller space as bottle storage instead. The area on the top can house compartments like pull out drawers to store dry fruits etc.

Customer benefit:

Storage area for 3-4 more 2 lit. bottles

Organized space for storage of small items which otherwise have to be stored in separate containers on the racks thereby wasting a lot of shelving space.

Better accessibility to water bottles .

Pull out drawer like compartments

The tray slides in and out

Profiled shelf made of rods or plastic to house bottles

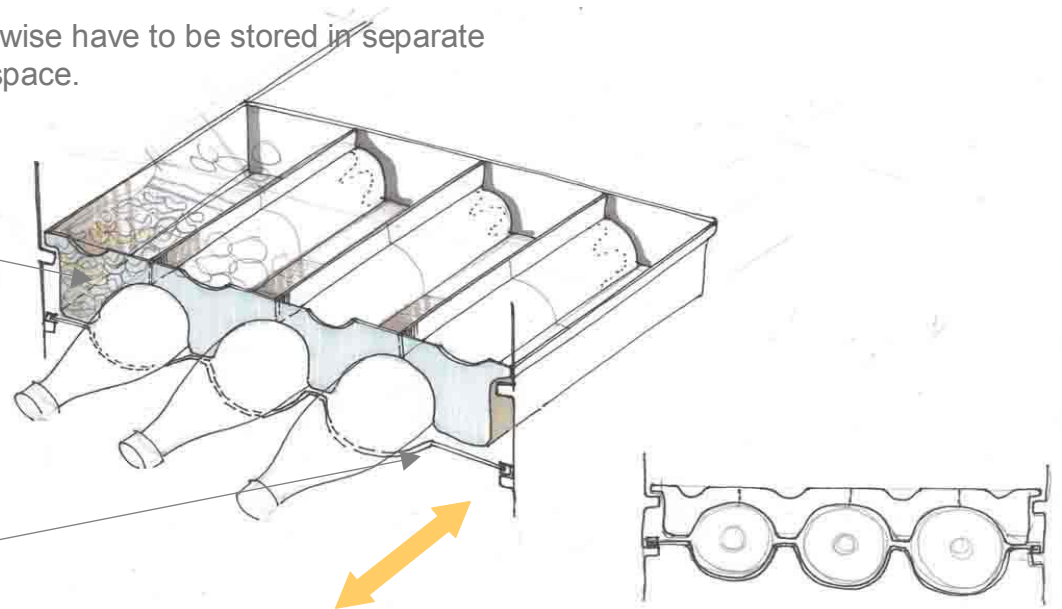

The corner spaces in the storage racks are wasted.
In this concept the idea is to make effective use of these corner spaces as well for storage of bottles.

Customer benefit:

added storage facility for water bottles
flexibility of use

A slot and a hook arrangement
for adjusting the grip

Straps made of elastic material
strapped around the bottle

Strap aligns to the liner
when not in use

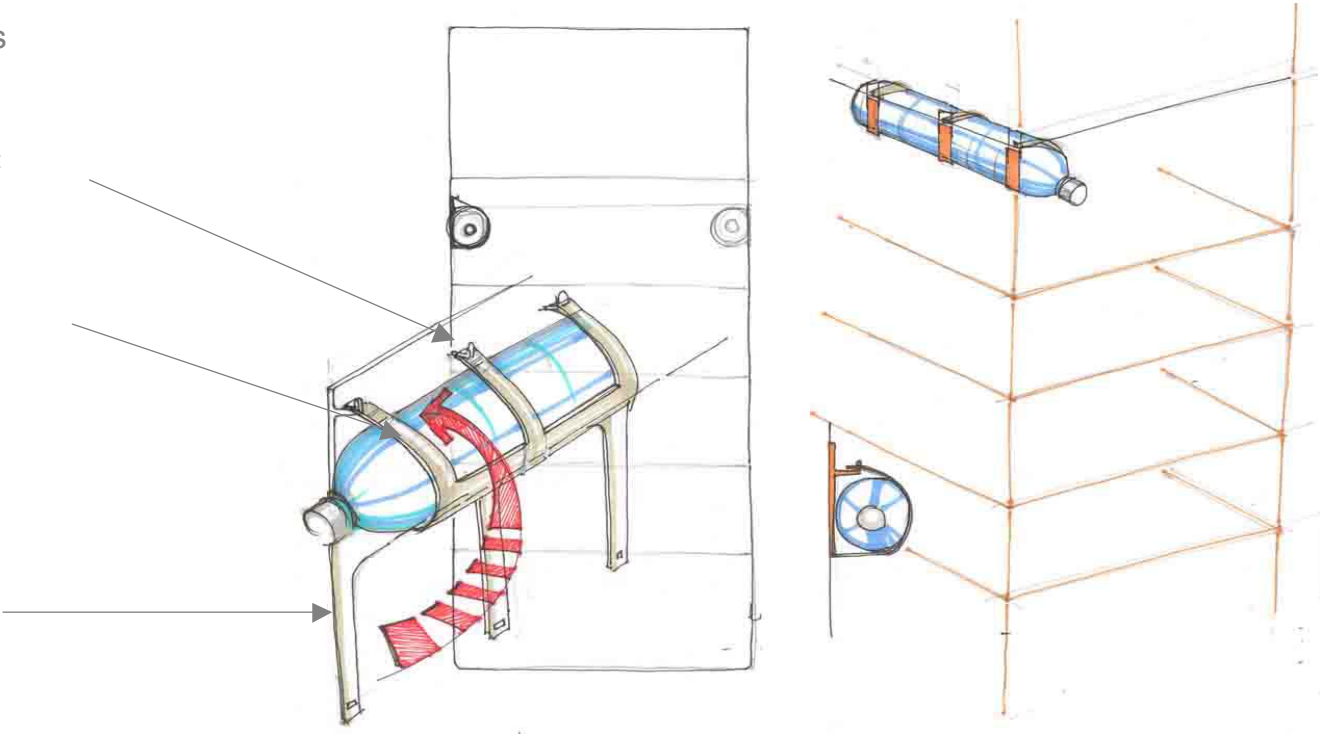

This is a similar concept where in a a flexible plastic material is used to create a bag like assembly, in which when a bottle is placed, it takes its shape.... Otherwise it collapses into a compact structure.

Customer benefit:

- flexibility of use
- use can be extended by using it as a carry bag for bottles while traveling

Flexible plastic bag

Plastic ropes for holding and carrying the bag

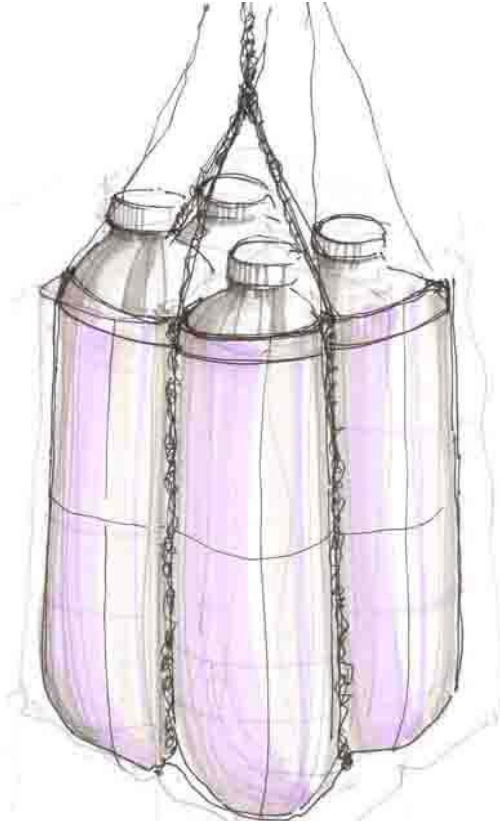
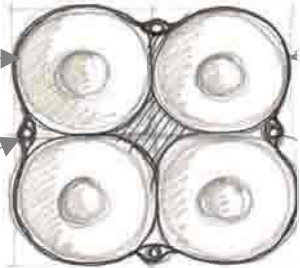

CRISPER

Many a times there is lot of space wastage in the cabinet (especially in the crisper)due to lack of its proper organization. This concept suggests a compartmentalization of the vegetable storage area.

Customer benefit:

systematic segregation of vegetables.

ease of operation while taking the containers in and out .

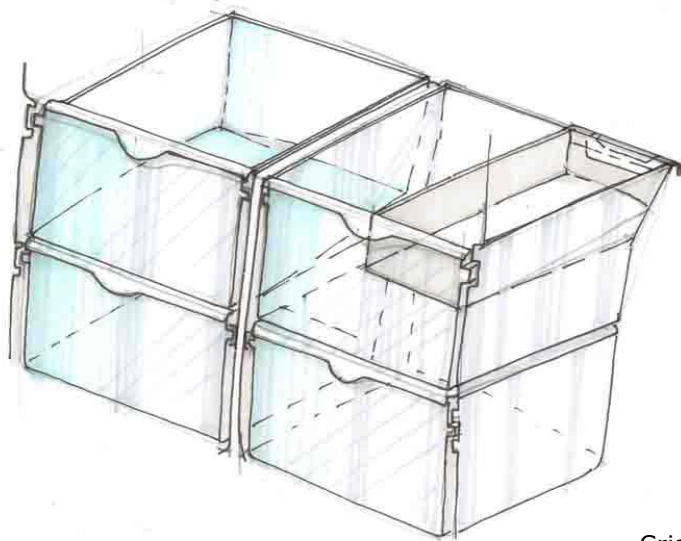

Crisper separator divided into smaller containers

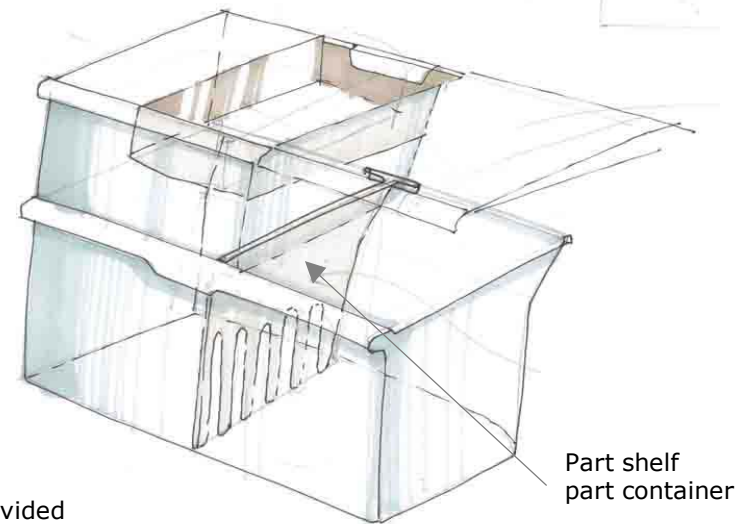

Part shelf
part container

EGG TRAY

In this concept, the egg tray can be hung down from the trivet (whenever more stuff needs to be stored in the trivet).... Whenever required, the same egg tray can be inverted to slide it in the trivet.

Customer benefit:

flexibility of use

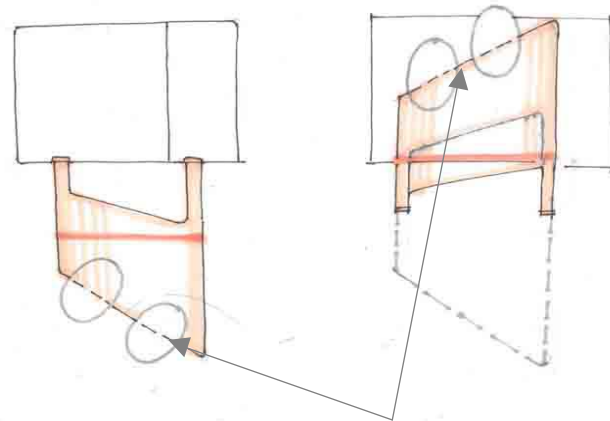
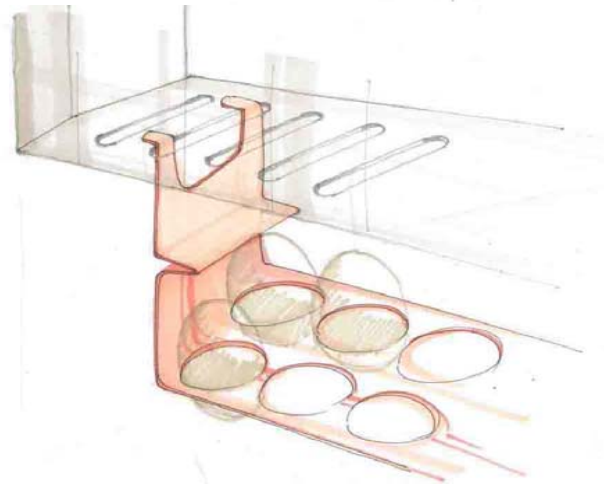
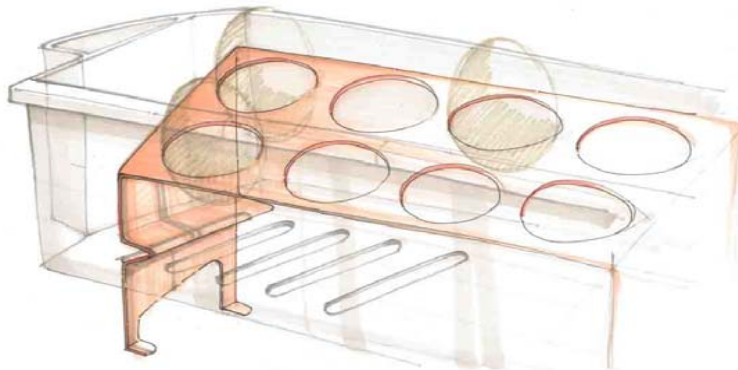

surface slant for better accessibility

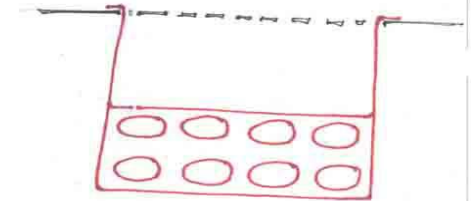
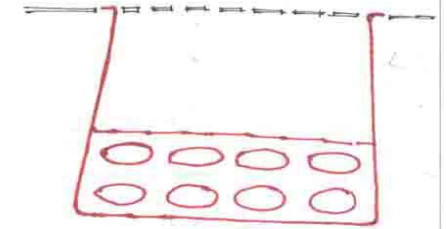

ICE TRAY

This concept eliminates the requirement of the plastic component in the freezer made to slide the ice twister.

The ice tray could attach to the plastic container itself and the whole assembly could cantilever from the side wall of the liner as seen in the illustration.

The support could be hinged so that when not required, the tray - container could be hinged along the wall of the liner as seen below so that it does not interrupt the freezer space.

This also saves material and cost.

Customer benefit:

flexibility of use of freezer space.

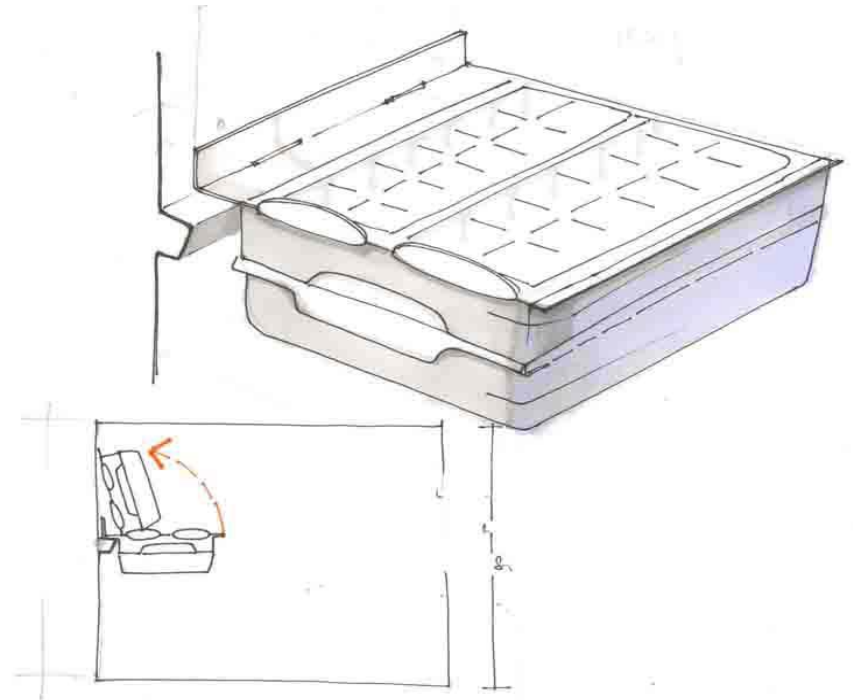

CABINET SHELVES OR TRAYS

This concept proposes a plastic component which can be fixed in the vertical plane to form containers from shelves. Also, when required it can be fixed in the horizontal plane to function as an additional shelf. When not required, it can be stacked along one of the shelves to save space.

Customer benefit:

flexibility of use

Position in vertical plane

SECTION

Position when not in use.

Possible locking systems to arrest the component

TOP VIEW

Position when used as shelf

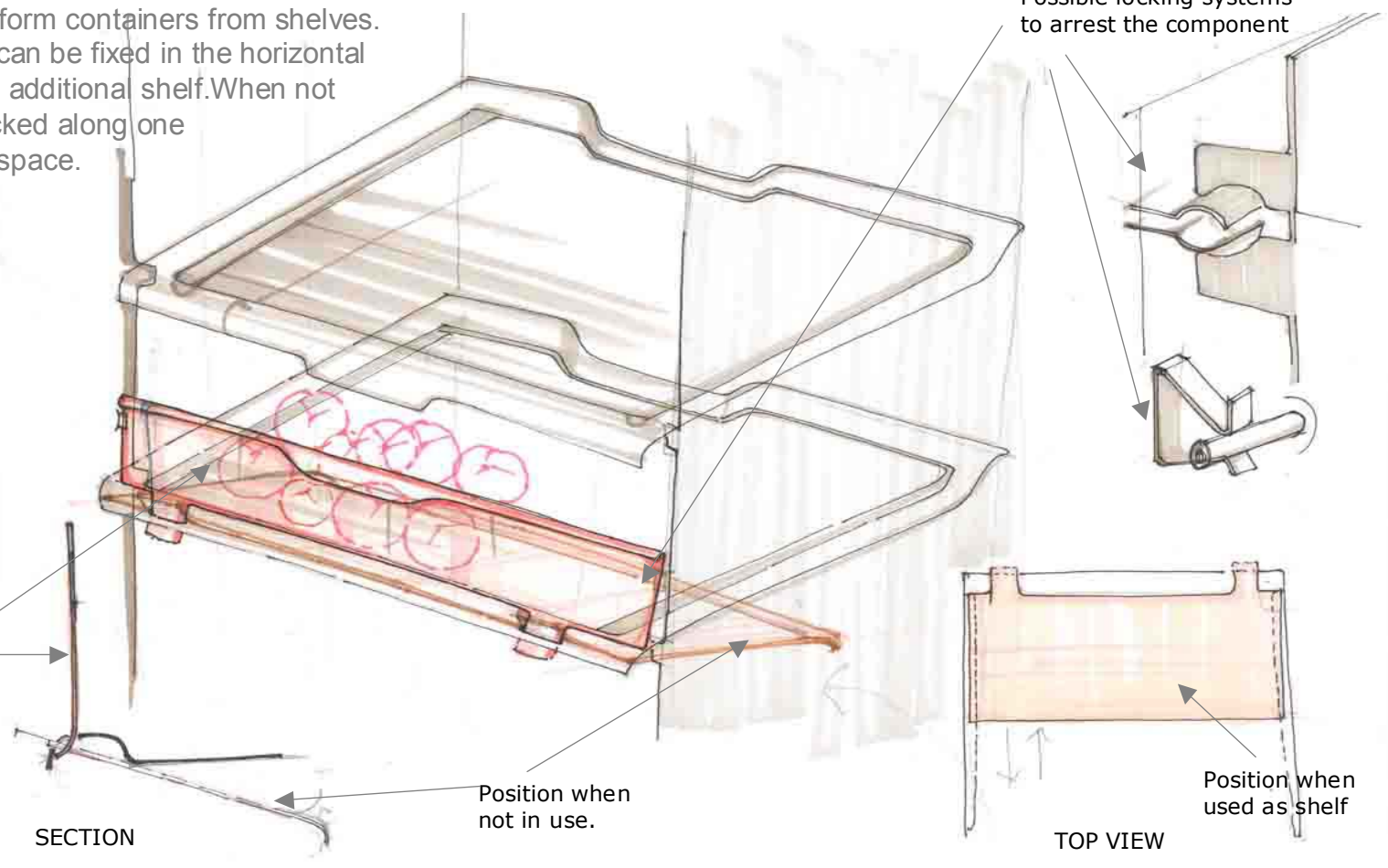

Small items like chilies, dhaniya, chocolates, dry fruits, etc. when kept in separate containers, take up lot of storage space in the cabinet area. This concept proposes a pull out drawer like system integrated with the shelf structure.

Customer benefit:
systematic categorization of compact storage spaces thereby resulting in the shelf space being used for storing bigger items

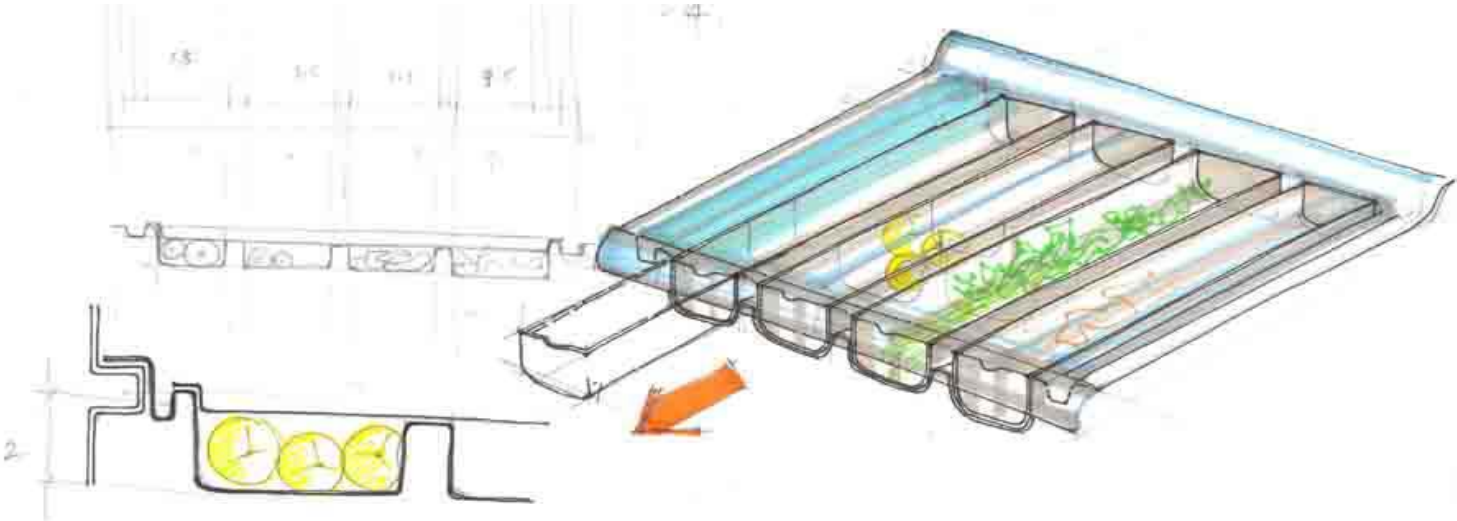

This concept proposes a system by which the location of shelves is not restricted by the location of the rails or supports. Here the shelves are held by rails made of tension cables like as seen in the illustration. The shelf can be located at any point along the rail. The shelf is arrested at a desired location with the help of a stopper.... When the stopper is released, the shelf can move freely along the rails.

Customer benefit: flexibility of use

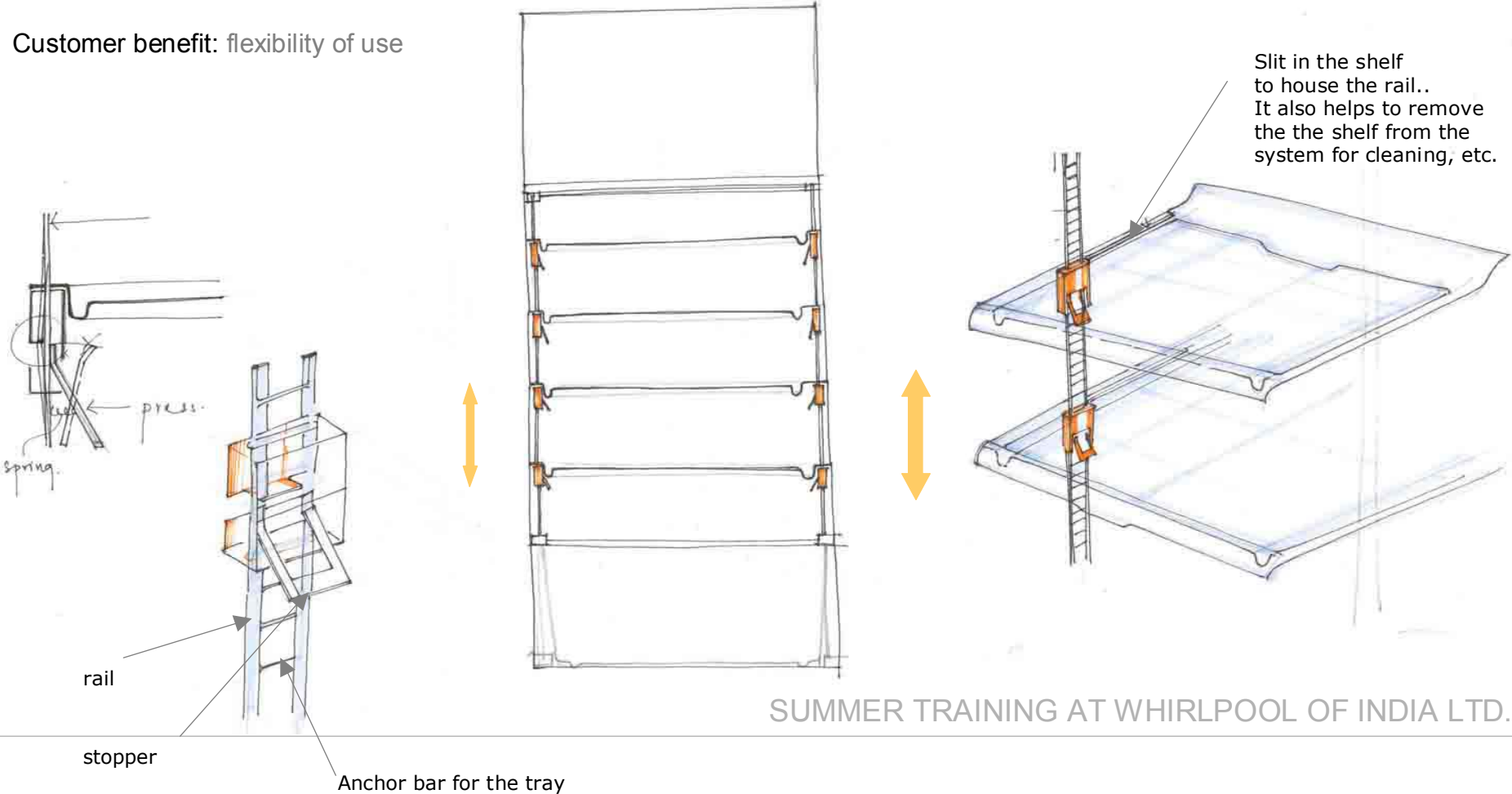

The concept proposes a tray that slides in and out of the bent rod channel.

As per the storage requirement,

- the tray can sit in the channel and hold stuff
- the tray can be stacked on any of the other shelves and channel space also can be used to stack leafy vegetables, etc.

Customer benefit:
flexibility of use

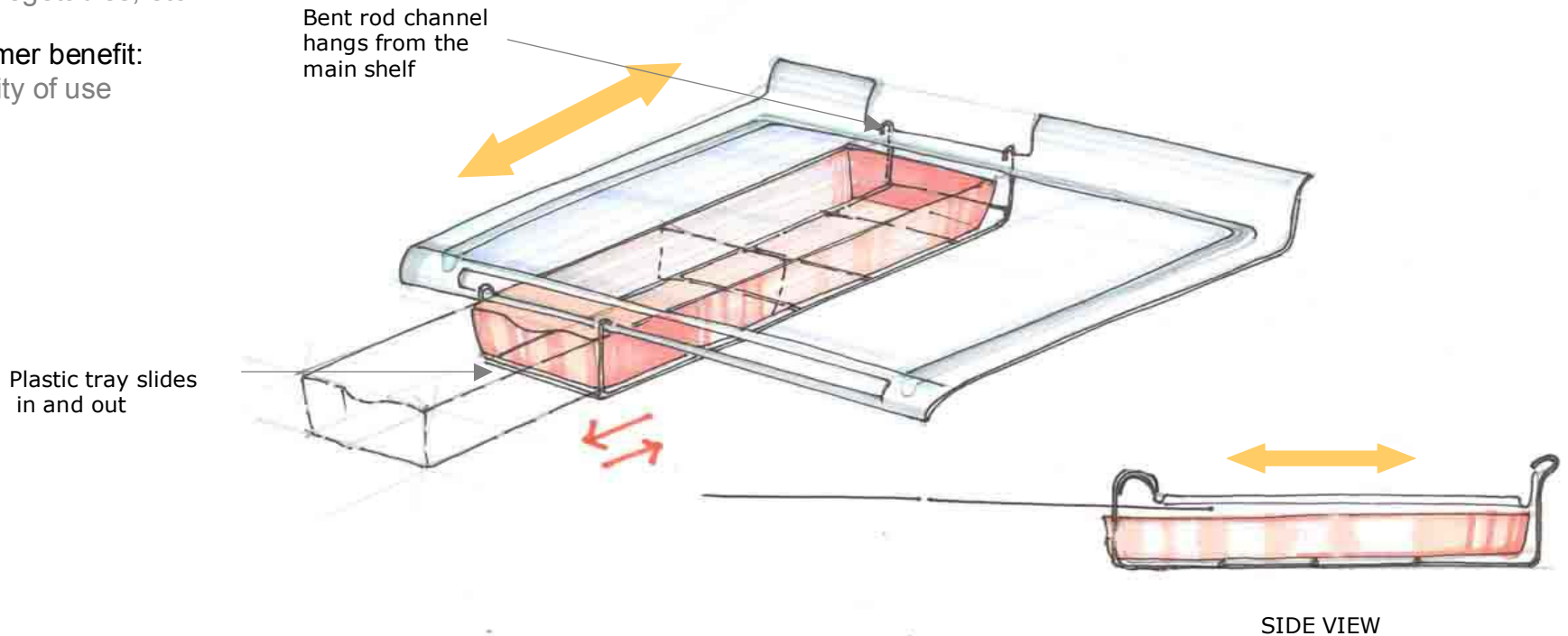

Here also the tray can be slid inside and out side.
When slid out, the angle of the opening makes it convenient for the user to take things out of it.
This tray can be used to store lemons, chilies, dhaniya, etc.

Customer benefit:
multipurpose use.

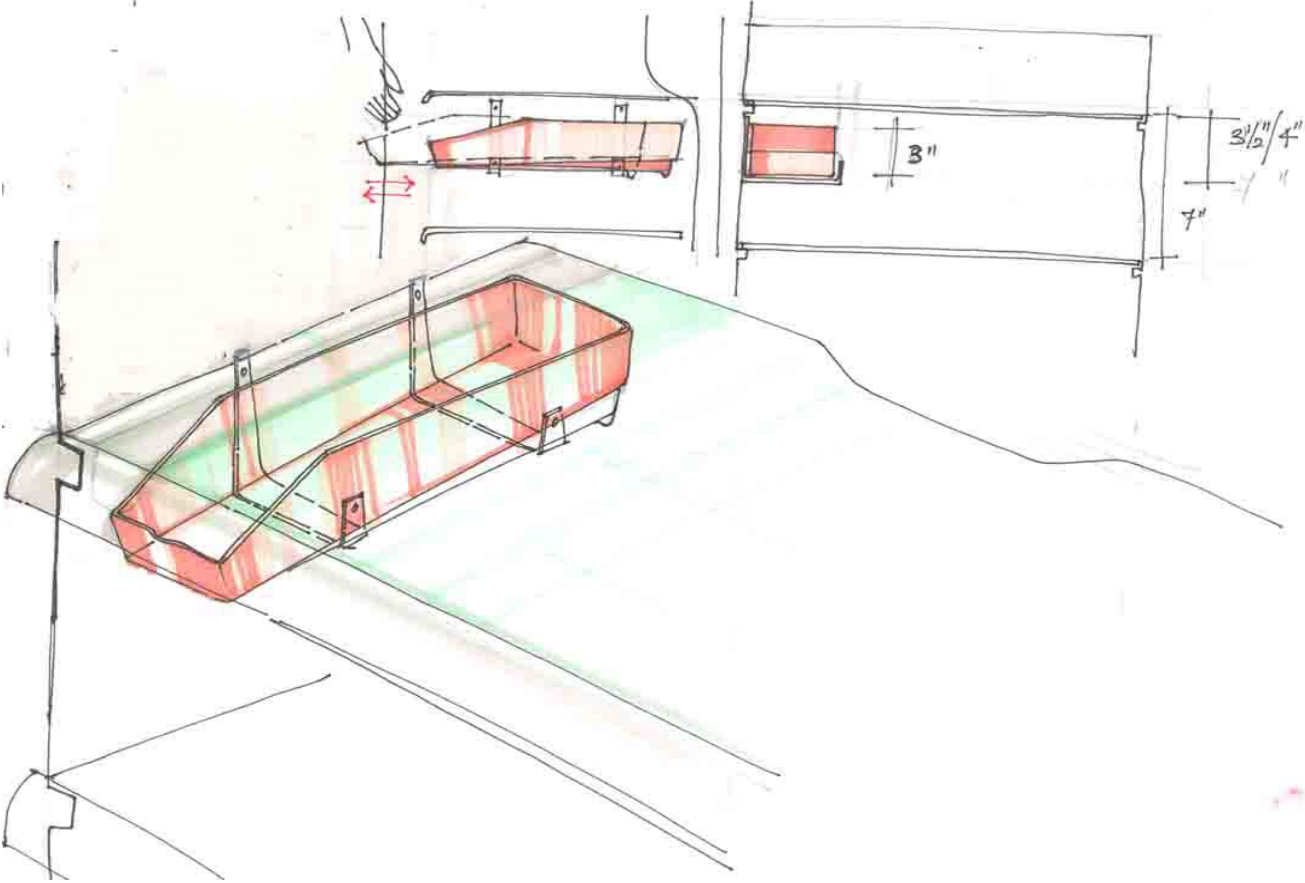

here, the idea is to create a depression in the front end of the current profile of the shelf. This space being highly accessible, can be used to store small items like chilies, ginger, toffees, etc. this would result in value addition to the product without introducing any additional components.

Groove to store small items

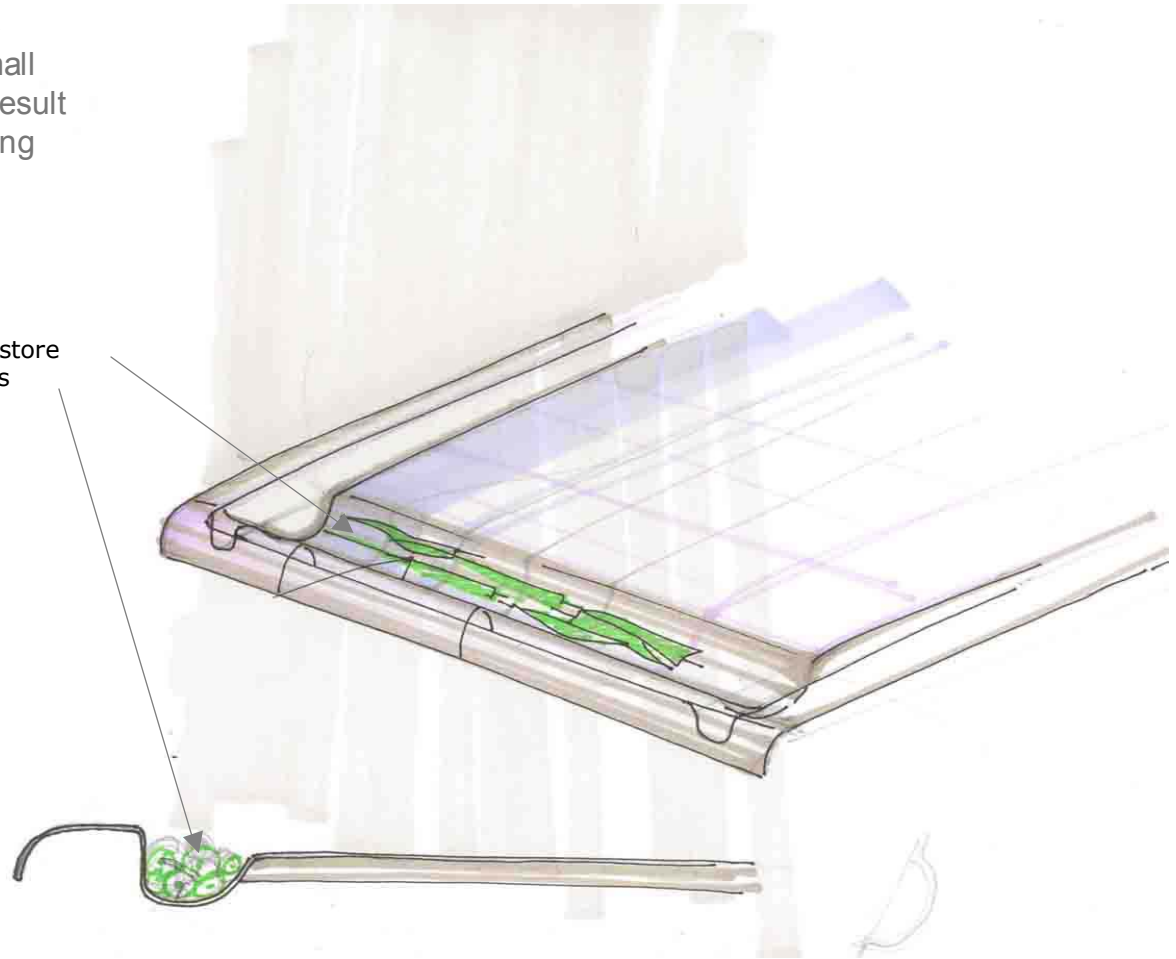

This concept suggests additional shelves in between the existing shelves. When not required, these can lean vertically against the back wall of the liner. When required they can be pivoted to function as horizontal shelves.

Customer benefit:

- more stacking facility due to additional shelves.
- Flexibility of use.

A pivot detail to move the shelf in the horizontal To vertical planes

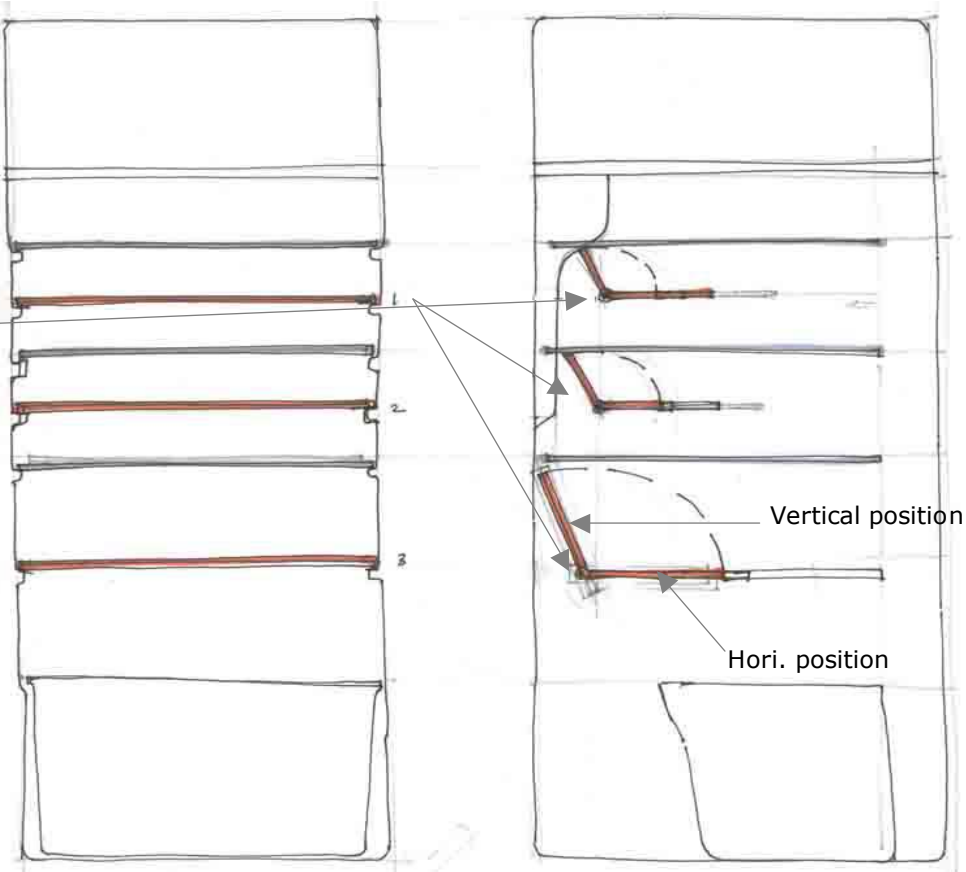

Here, the concept is that when an extra shelf is desired, the shelf is pulled and rolled open as seen in the illustration. The rods slide on plastic rails on side walls of the liner. When not required, the shelf is rolled back.

Customer benefit:

- more stacking facility due to additional shelves.
- Flexibility of use.

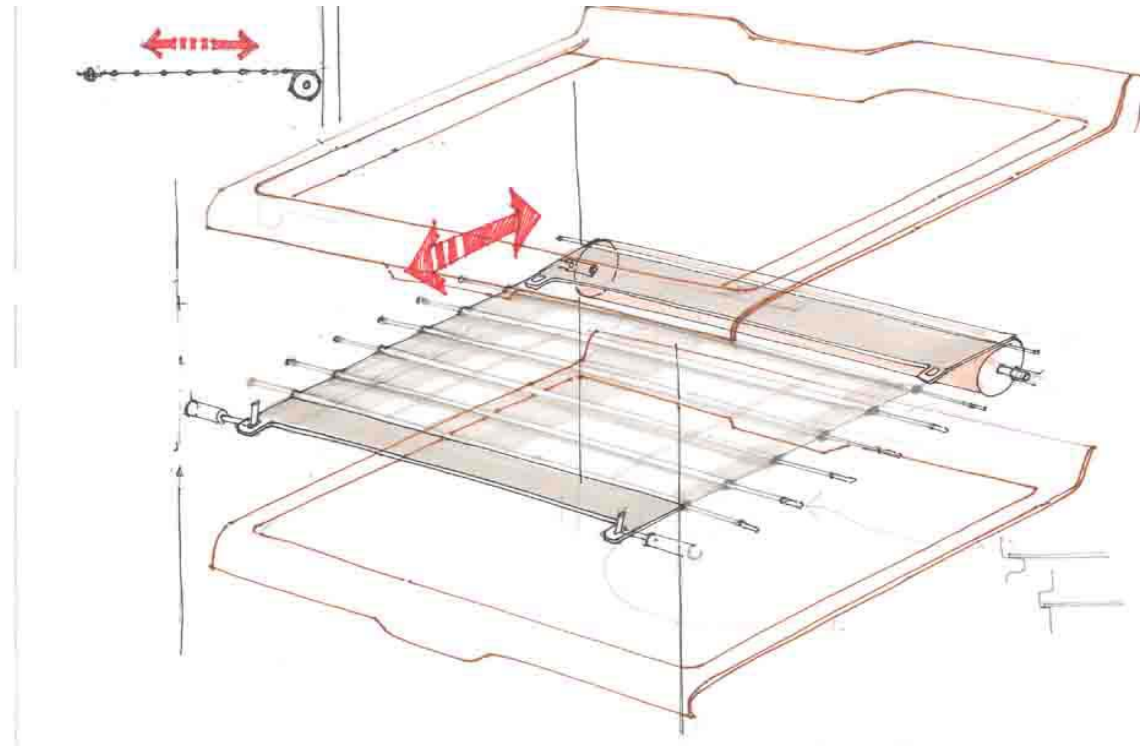

The space near the side wall of the liner is generally not occupied and tends to go waste. This concept suggests a box-like 2 1/2 inch wide container attached to the side wall of the liner to store small items like chilies, chocolates, etc.

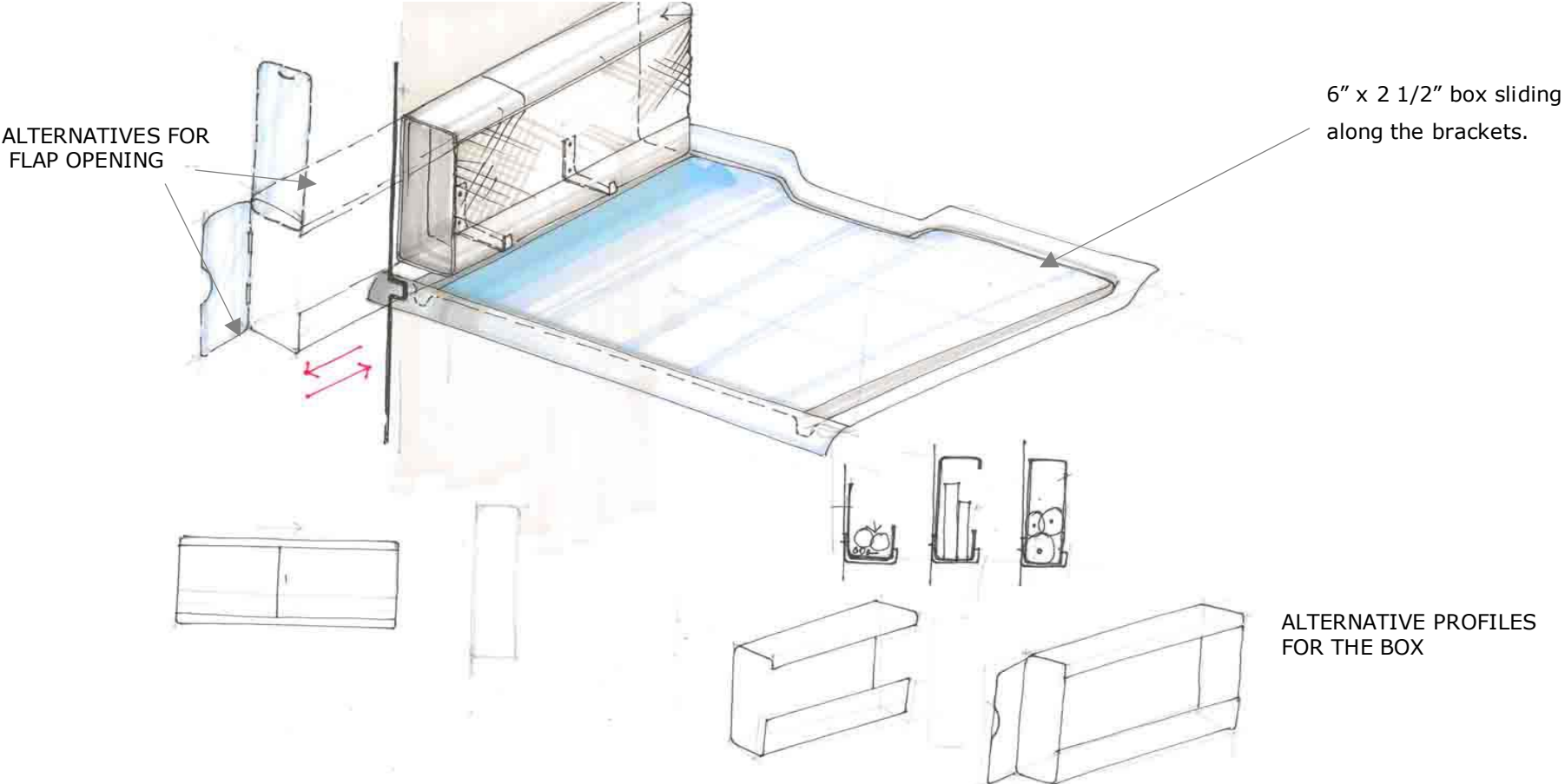

EXTERNAL STORAGE

This concept suggests creating some possibility of storage on the outside of the refrigerator. Small things that need shelving space but not refrigeration can be stored here.

Customer benefit:

value addition to the product

Shelves can slide up and down for flexibility.

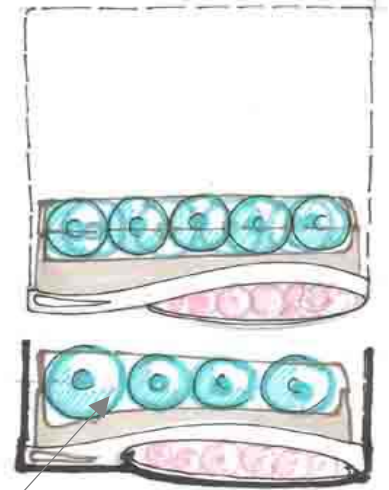
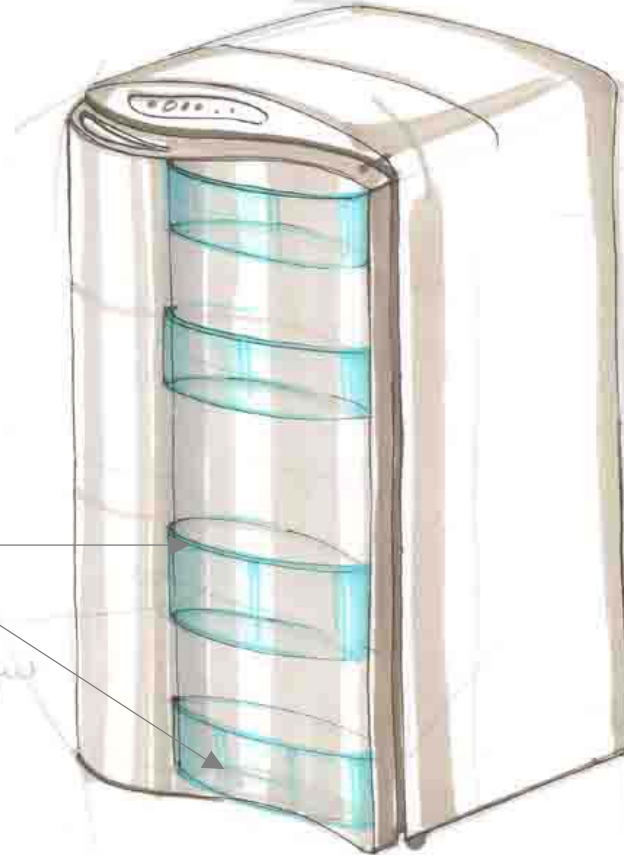

More space for bigger bottle.

TOP VIEW OF DOOR PROFILE

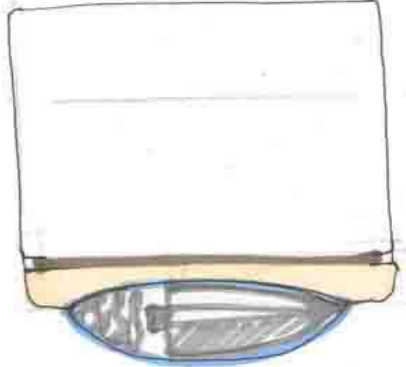

TOP VIEW

A concept suggesting the out side of the refrigerator to be used as an ironing kit (with a collapsible ironing table and storage for the electric iron) as shown in the illustration.

Customer benefit:

value addition to the product.

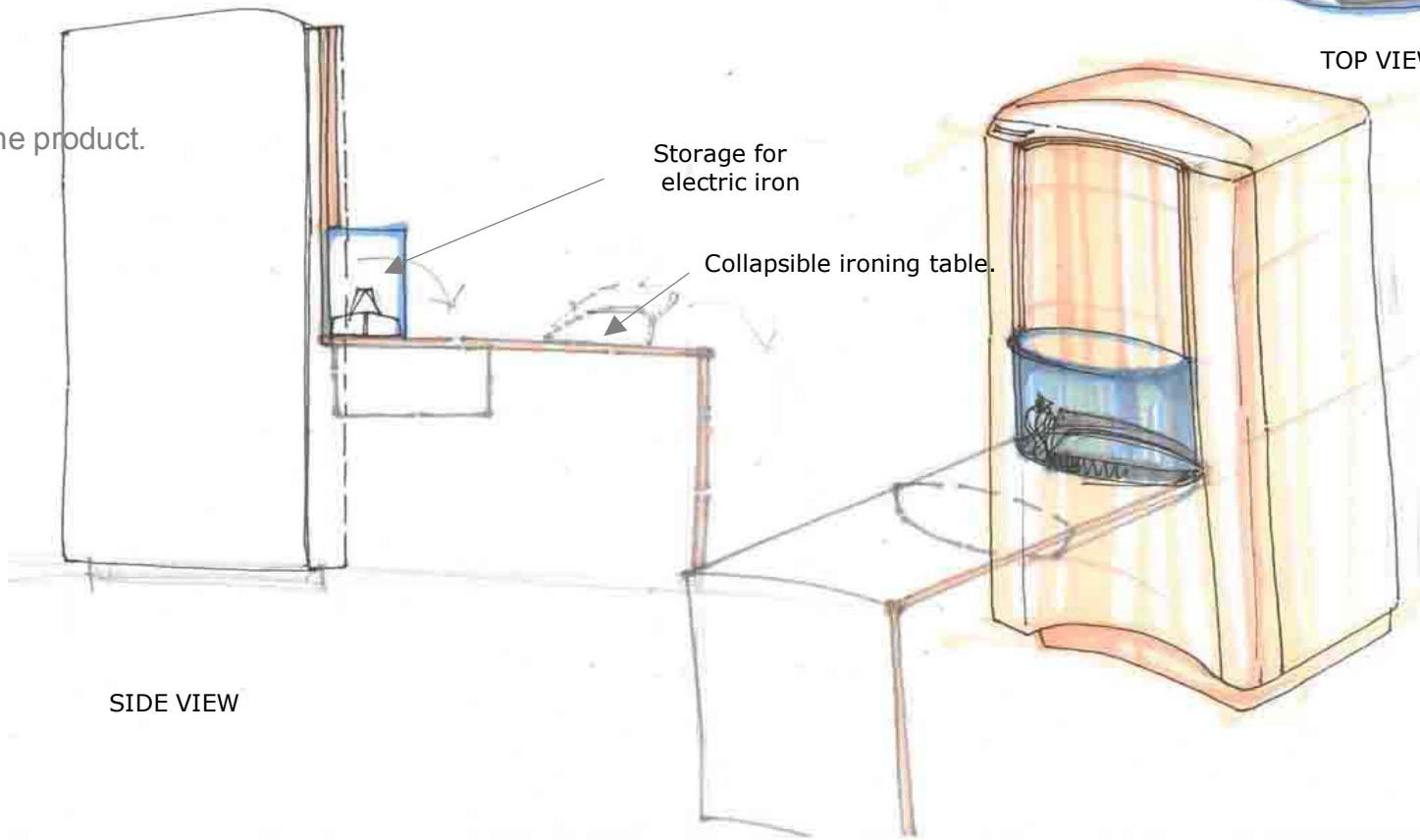

SIDE VIEW

Concept of a refrigerator with a dressing table.

Customer benefit;
value addition to the product.

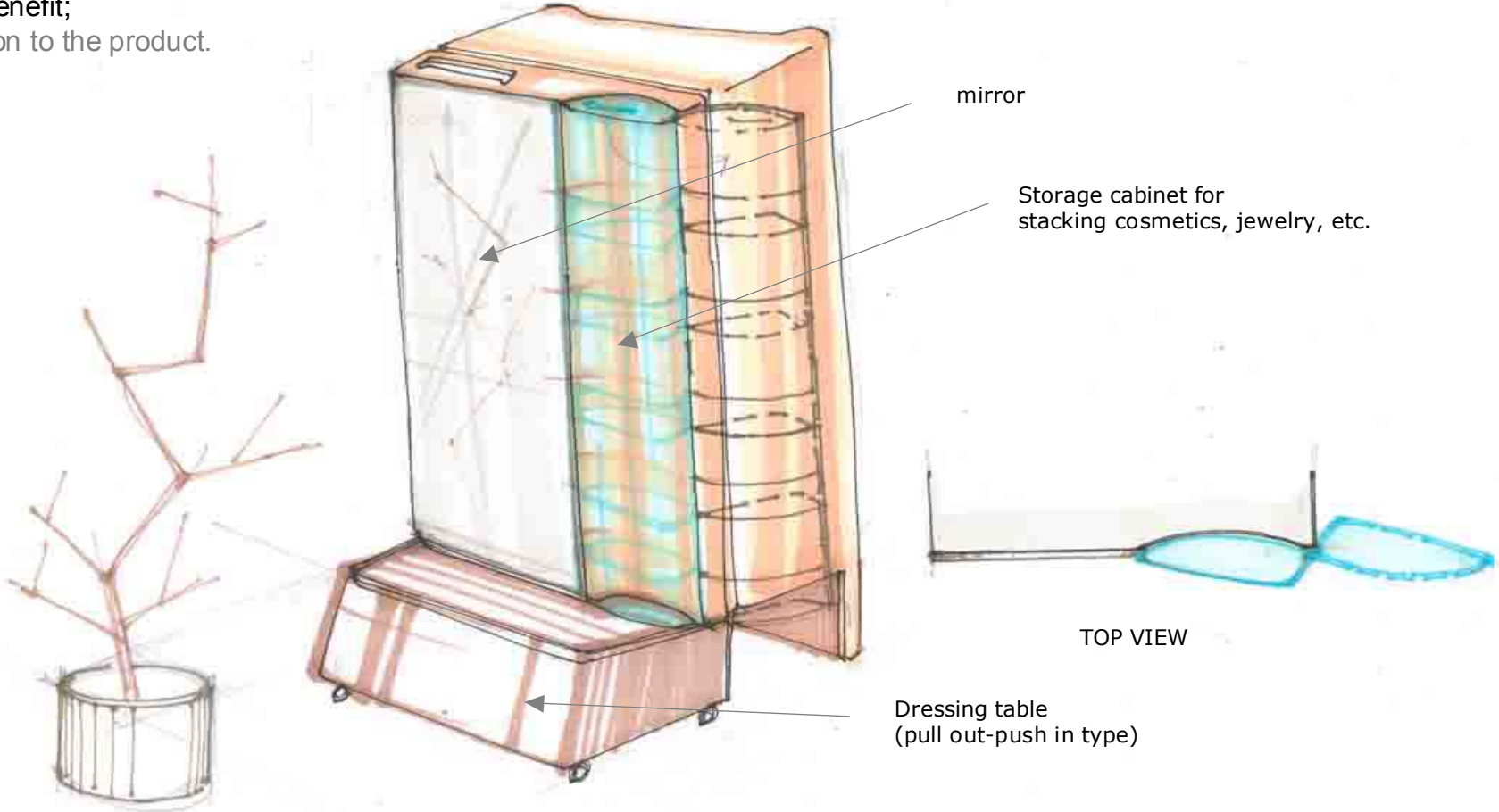

Here, the front wall of the refrigerator is slanted to create external storage space near the bottom, and wider storage space in the top trivet on the inside. The outer space can be used to store magazines, etc. and the wider inner space can be used to store frequently required stuff like chilies, lemon, etc.

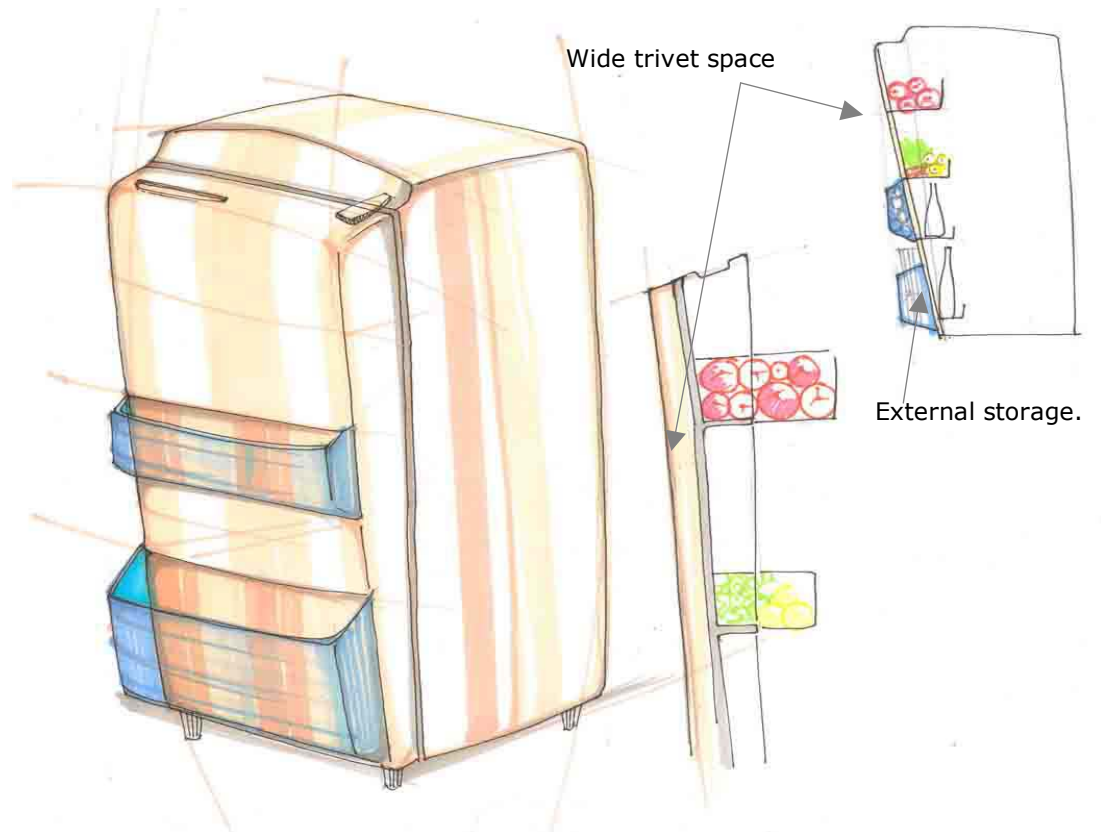

In this concept, an extra compartment is proposed on the front wall of the refrigerator with a separate door as seen in the illustration.

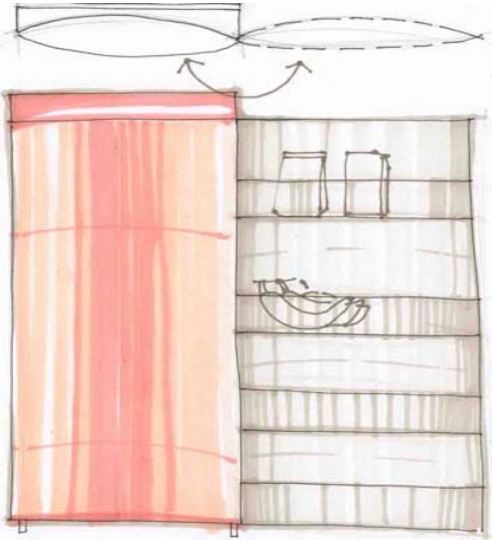

FRONT VIEW

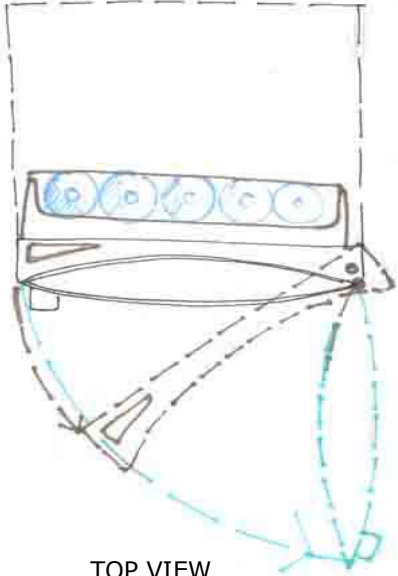
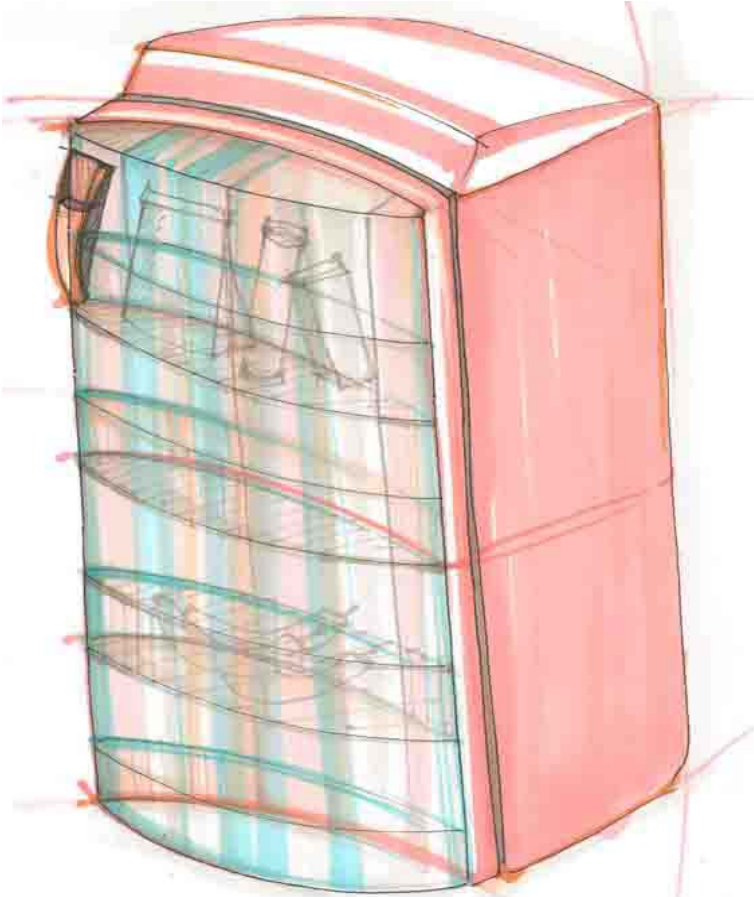

TOP VIEW

A set of trivets suspended from a pair of suspended cables supported on the front face of the refrigerator.

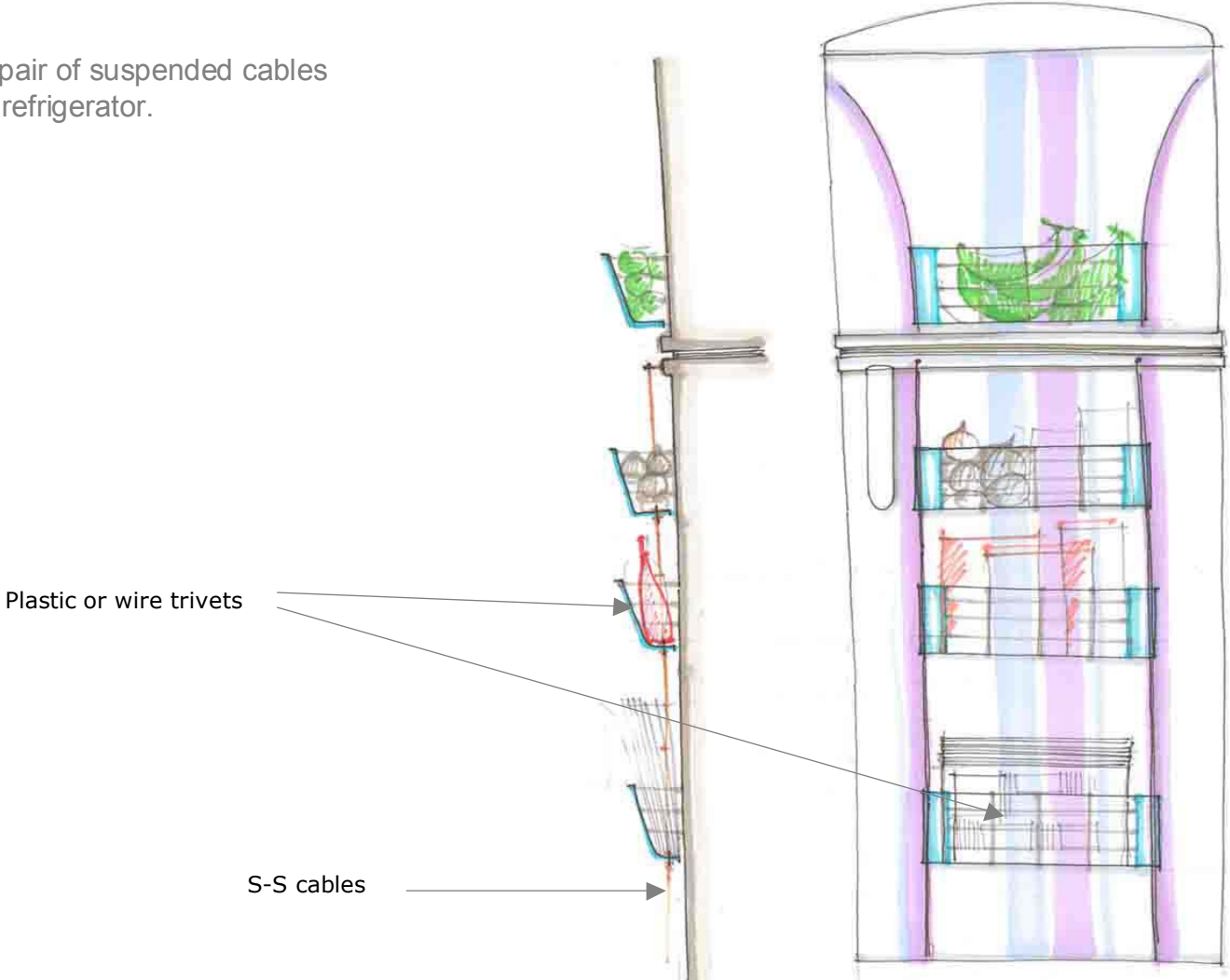

A set of separate containers hung from inbuilt grooves in the front surface of the refrigerator. They can be removed if not required or their position needs to be shifted.

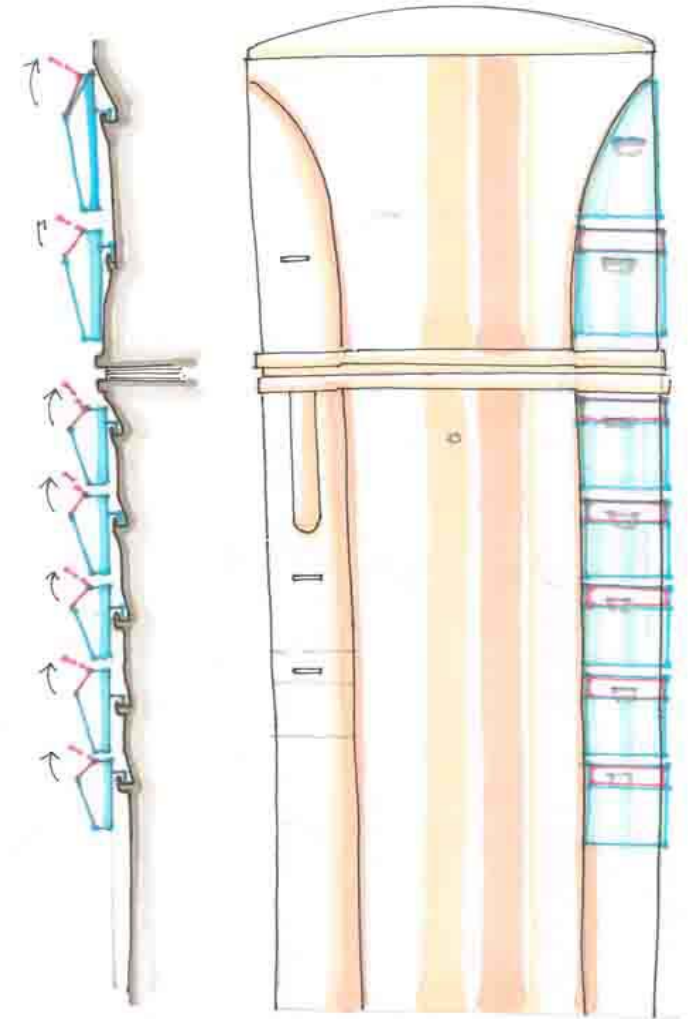

A similar concept where the containers can slide up and down as per convenience of the user.

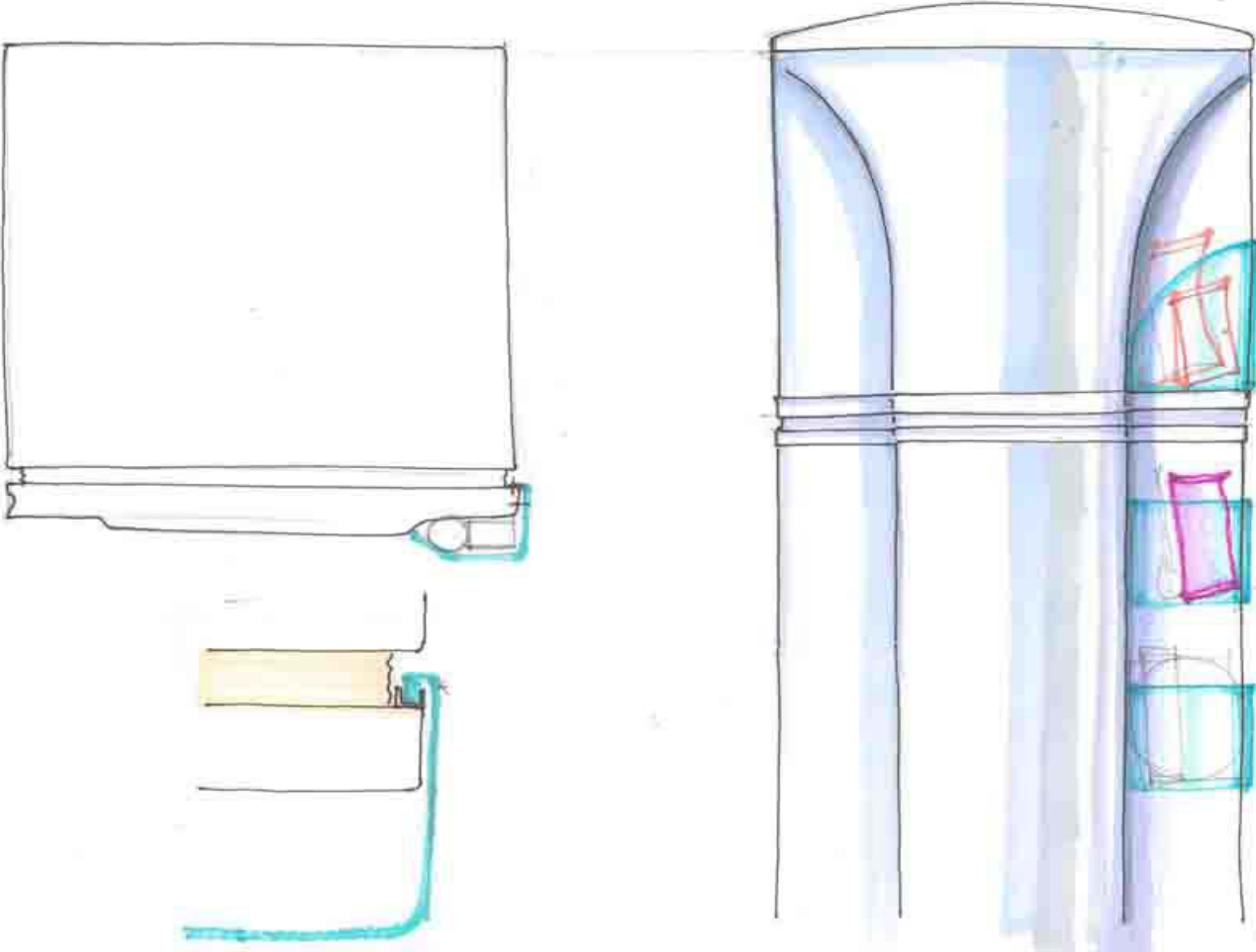

NEW CONCEPTS FOR REFRIGERATORS

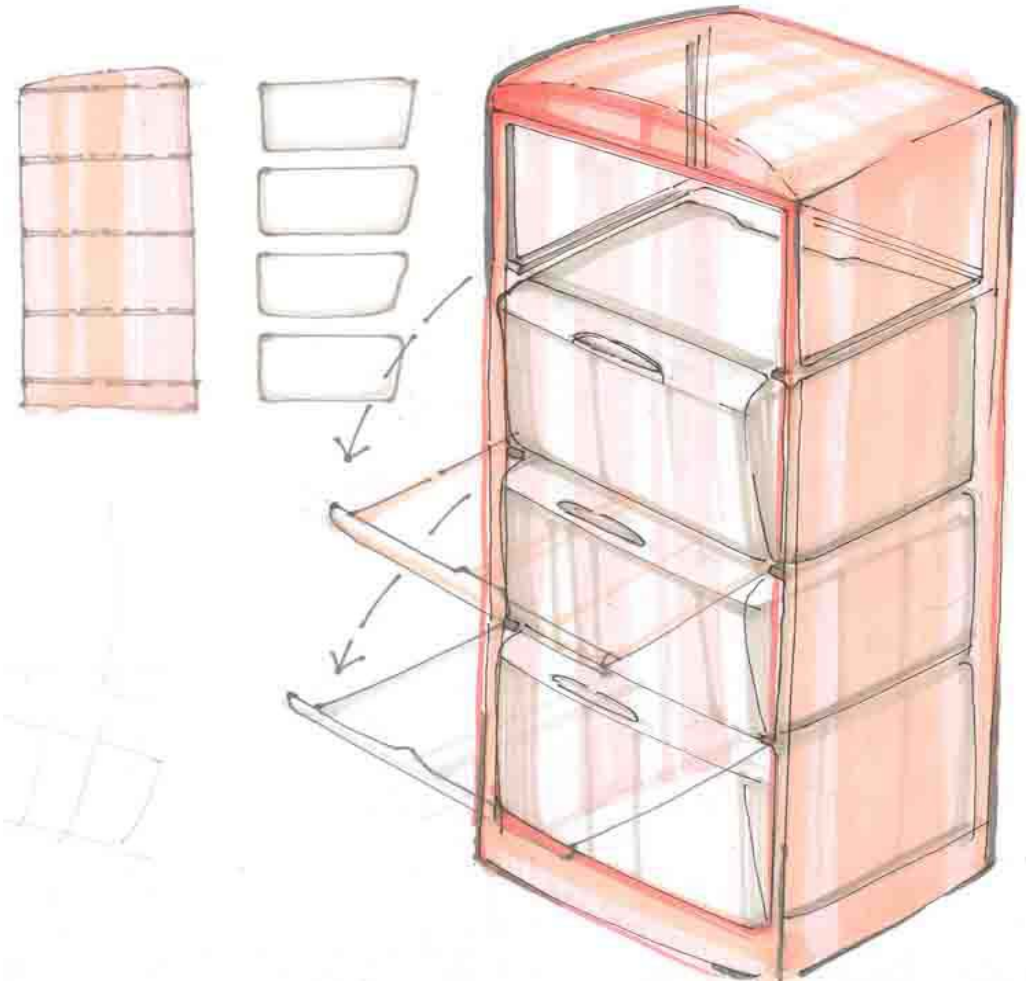

The refrigerator could be in fragments which could have added value addition of being furniture pieces like stool, table, etc. when kept separately. When the fragments are out, the empty casing could act as a huge storage unit in itself (like a cupboard).

Customer benefit:

value addition to the product and additional storage facility.

This is a concept for a circular refrigerator .

The idea here is to have controlled access to the cabinet area, thereby trying to reduce on the heat loss resulting from constant opening of the door.

Also here, the cabinet shelves rotate around a central pivot for easy access to all sides of the shelf.

The the she;f area can be divided into part container-part stacking, full stacking, like flexible arrangements.

Customer benefit:

- less energy loss
- easy access to shelf storage
- flexibility of use

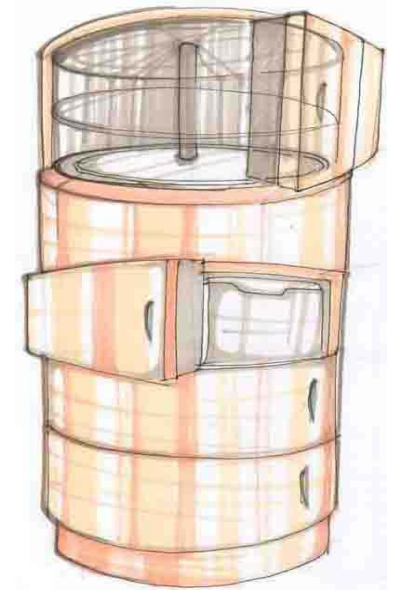
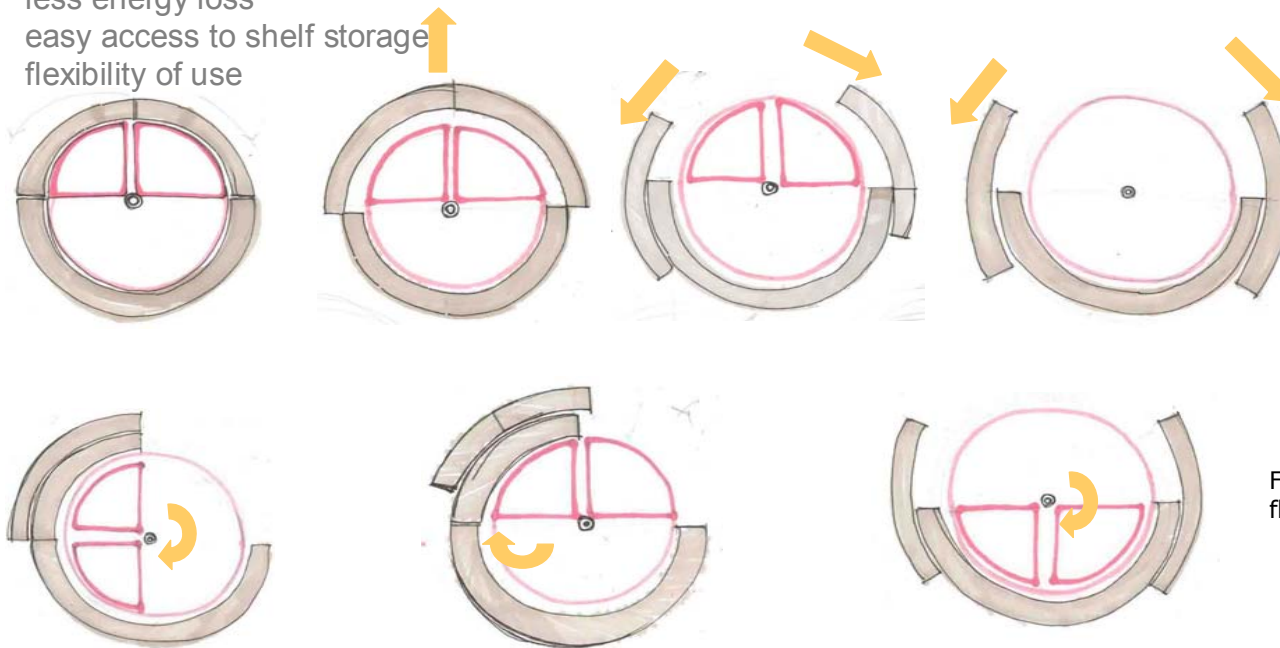

Figures show flexibility of usage

Space is a major constraint, especially in the urban kitchens. Also most of the time corner spaces in the rooms are wasted. Therefore the concept of a 'corner refrigerator'.

Customer benefit:

- compact product
- better accessibility (as the door opening size increases)
- more area for storage on the door

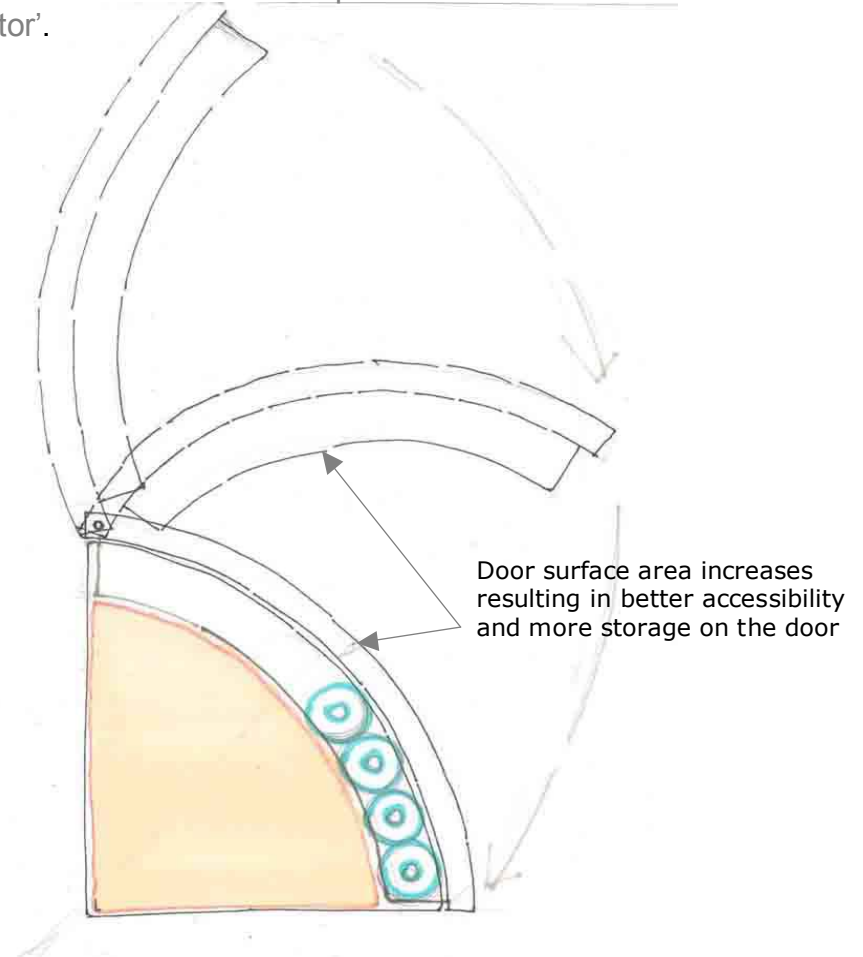

The door is one of the most accessible areas of the refrigerator. In this concept, the idea is to increase the accessibility of the crisper by having a part of vegetable storage on the door..a part of the crisper is in the cabinet. Some part of the cabinet can also be used to store bottles.

Customer benefit:

better access to vegetable storage
additional bottle storage area.

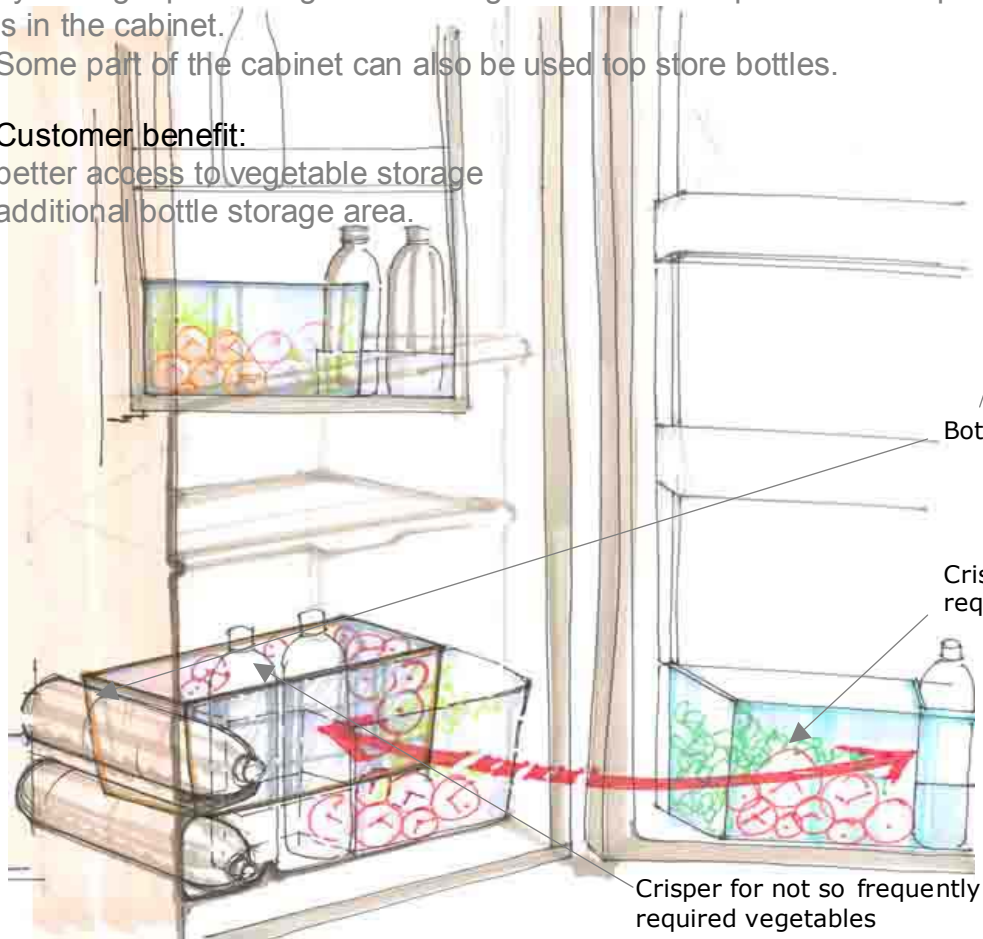

Bottle storage

Crisper for frequently required vegetables

Crisper for not so frequently required vegetables

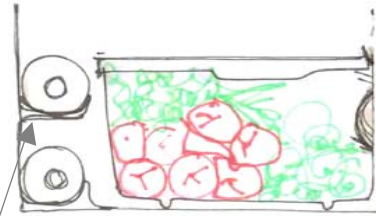

FRONT VIEW-CABINET

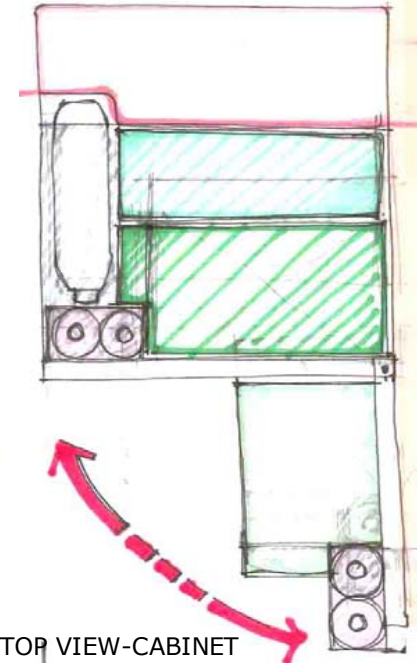

TOP VIEW-CABINET



FRONT VIEW-DOOR

This concept proposes that the shape and spacing between the rails should be such that it provides flexibility in positioning the crisper.... that is it should be able to be stacked on any if the supports.

Customer benefit:

flexibility of positioning the crisper as per convenience.

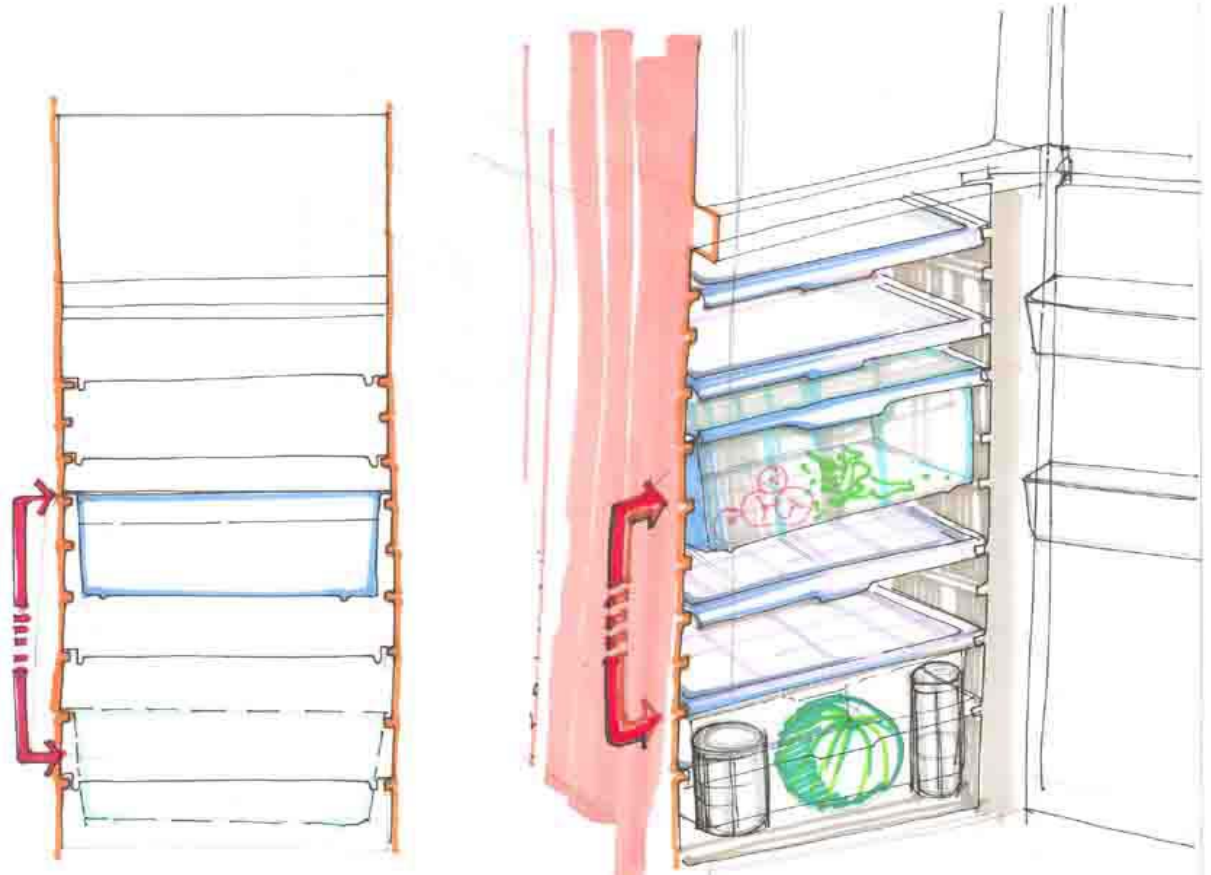

The manual pulling out and pushing in of the crisper makes it highly inconvenient to use it. This concept proposes a system by which whenever the door opens, a set of linkages pull the crisper out. The crisper edges would move on rollers to achieve smoothness of movement. When the door has to be closed, the user can easily push the crisper with the help of his/ foot. At the same time, the linkages would fold into the cabinet as seen in the illustration.

Customer benefit:
the user doesn't need to bend to pull out or push in the heavy crisper
linkage system can be detached when not desired for flexibility.

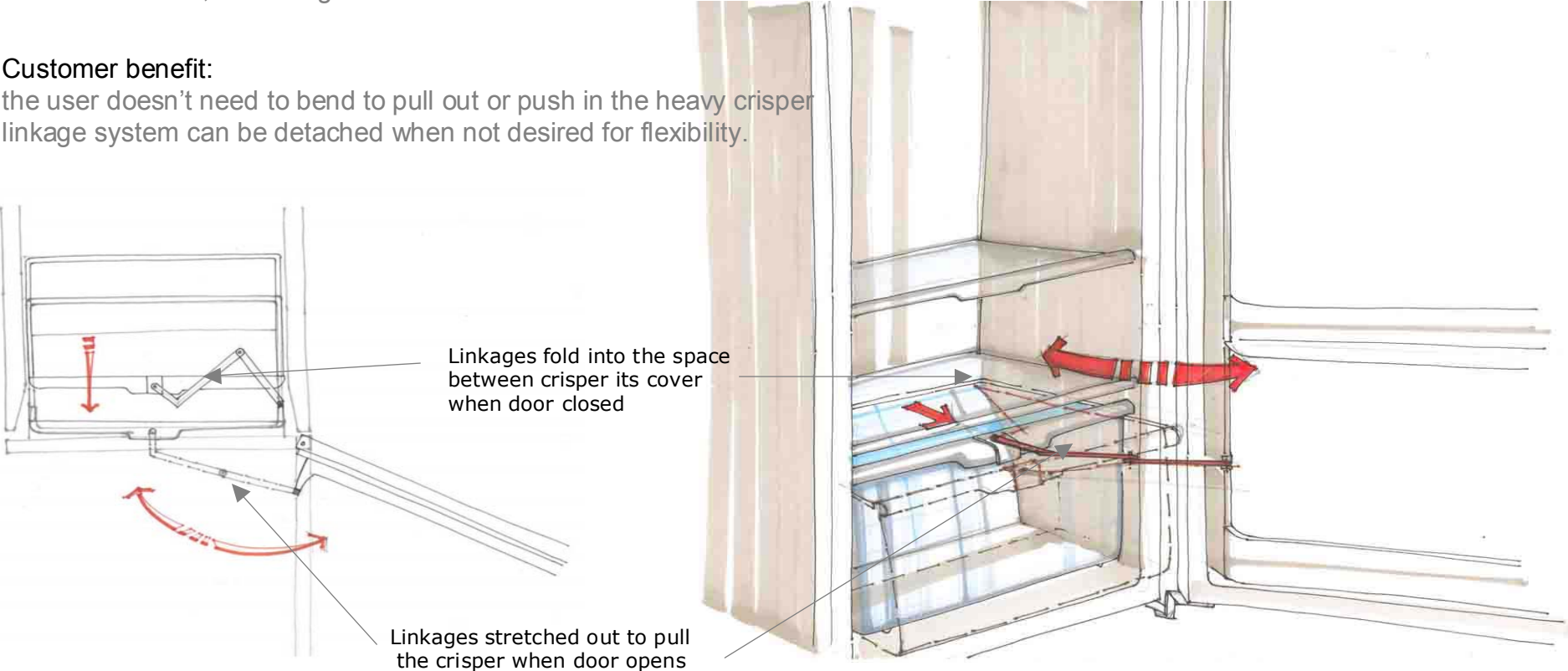

The freezer is not extensively used regularly by many usersso mostly the freezer space is underutilized.
This concept proposes an arrangement by which the partition between the freezer and the refrigerator compartments could be movable such that the freezer space can be increased only when required, otherwise that space can be integrated into the refrigerator compartment.

Customer benefit:

less wastage of storage space in the freezer
flexibility of use.

