

P3 Defence

# Optimizing Smartphone Interruptions through a Smart Notification System

---

Vivek Paul Joseph  
IxD, IDC


Guide:  
Prof. Jayesh Pillai

 P3 Defence • Now

---

# Introduction

Research Problem

 P3 Defence • In 1 min

Primary/Secondary Research

CLEAR ALL

# Introduction

- Smartphone notifications are a major source of interruptions



Image Source: <https://goo.gl/images/lpFe7B>

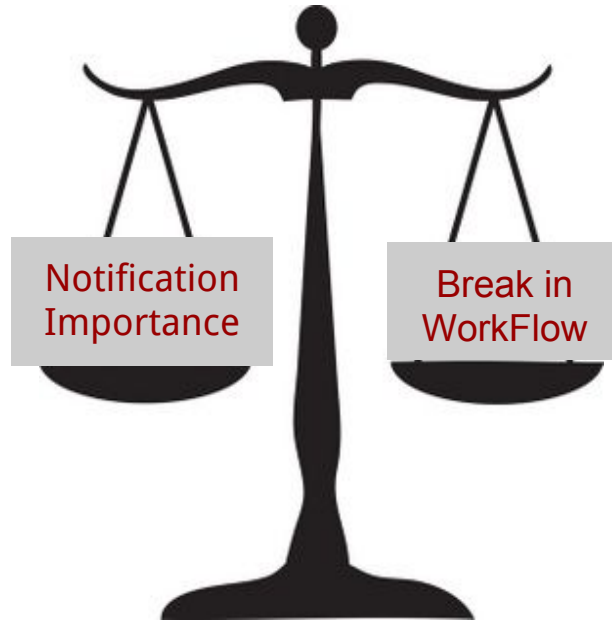
# Introduction

- Notifications popping up during inopportune moments break the flow of work

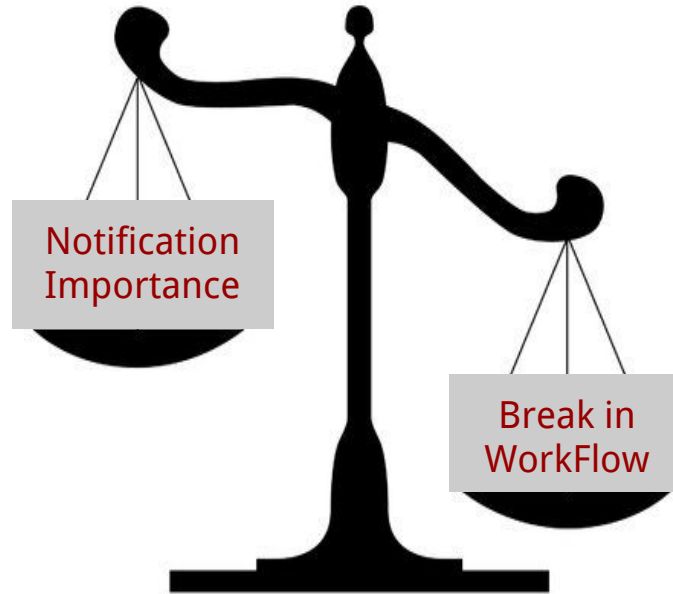


Image Source: <https://goo.gl/images/lpFe7B>

# Interruption Payoff Scale



# Interruption Payoff Scale



# Objective

Reduce the number of interruptions generated by smartphones

# Objective

Reduce the number of interruptions generated by smartphones

Through

# Objective

Reduce the number of interruptions generated by smartphones

Through

A **personalised** smart notification management system that **learns** from user behaviour and **screens** low priority interruptions

# Approach: Preliminary Research

- Unstructured interviews with users
  - Is there a problem?

# Approach: Secondary Research


- Reviewed Existing methods to control notifications
- Reviewed Research Papers on:
  - Disruptive effects of smartphone notifications
  - Interruption Management for smartphones

 P3 Defence • Now

---

# Primary Research

Interviews & Data Collection

 P3 Defence • In 5 mins

Design Implications

CLEAR ALL

# Primary Research: Interviews

- Semi-structured interviews:
  - Users' subjective opinion of how many notifications they receive daily
  - Users' subjective opinion of whether notifications seem intrusive
  - How they manage notifications?

# Primary Research: Data Collection

- Platform in scope: Android

# Primary Research: Data Collection

- Input required for Notification Manager Algorithm
  - **Parameters**, whose values can help predict relevance of notification
  - Pre-classified data from users (**Training data**)

# Primary Research: Selection of Parameters

- Preliminary list based on what can be measured by android

# Primary Research: Selection of Parameters

- Preliminary list based on what can be measured by android  
(and could help predict relevance of the notification)

# Primary Research: Selection of Parameters

- Preliminary list based on what can be measured by android
- App/Package Name
  - Date of receipt
  - Time of Receipt
  - Time of Consumption
  - Priority of message
  - Text Content of the notification
  - Title of notification
  - User Activity on receipt of notification
  - User Activity on consumption of notification
  - User state at the point of receipt of notification
  - Was the user using the phone at the point of receipt of notification
  - User Location on notification receipt
  - User Location on notification consumption
  - User response

# Primary Research: Selection of Parameters

- Preliminary list based on what can be measured by android
  - Filter out unviable parameters
    - User Activity, location:  
Resource intensive
- App/Package Name
  - Date of receipt
  - Time of Receipt
  - Time of Consumption
  - Priority of message
  - Text Content of the notification
  - Title of notification
  - User Activity on receipt of notification
  - User Activity on consumption of notification
  - User state at the point of receipt of notification
  - Was the user using the phone at the point of receipt of notification
  - User Location on notification receipt
  - User Location on notification consumption
  - User response

# Primary Research: Selection of Parameters

- Preliminary list based on what can be measured by android
  - Filter out unviable parameters
- App/Package Name
  - Date of receipt
  - Time of Receipt
  - Time of Consumption
  - Priority of message
  - Text Content of the notification
  - Title of notification
  - User response

# Primary Research: Data Collection

- Develop a Data Collection Tool

# Primary Research: Data Collection

- Develop a Data Collection Tool
  - To be installed in the user's smartphone

# Primary Research: Data Collection

- Develop a Data Collection Tool
- Developed in Android Studio



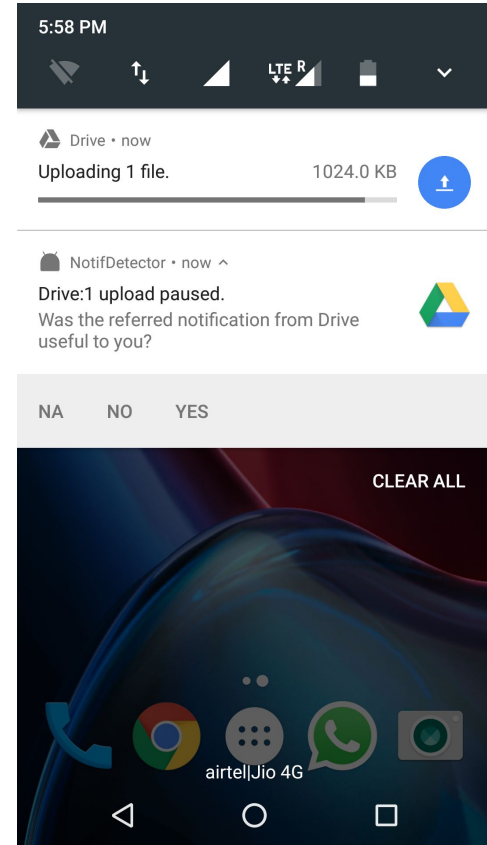
# Primary Research: Data Collection

- Develop a Data Collection Tool (DCT)
- Developed in Android Studio
- DCT installed on 8 users' devices
  - 7 users - 1 week
  - 1 user - 4 weeks



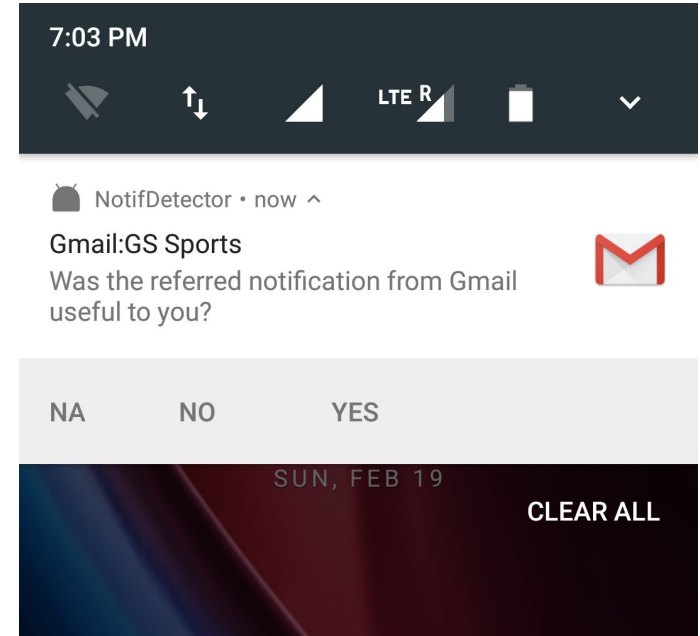
# Data Collection: Tool Development

- User response collection
  - Thru a notification from Data Collection Tool



# Data Collection: Tool Development

- User response collection
  - Thru a notification from Data Collection Tool
- Notification contains:
  - App name
  - Notification title
  - Response buttons



# Primary Research: Recap


- Semi-Structured Interviews
- Data Collection Tool

 P3 Defence • Now


---

# Design Implications

Derived from primary and secondary research

 P3 Defence • In 2 mins

Design

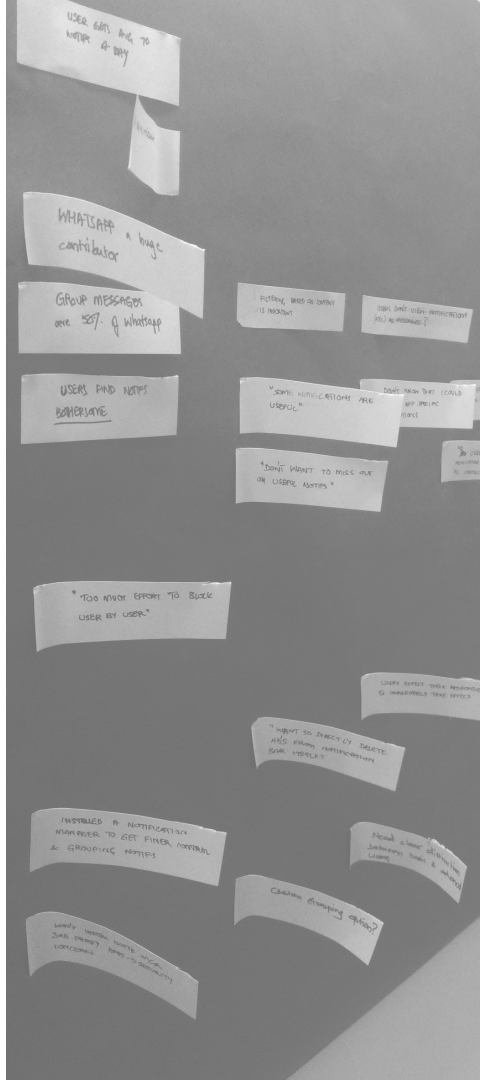
 P3 Defence • In 10 mins

Evaluations

CLEAR ALL

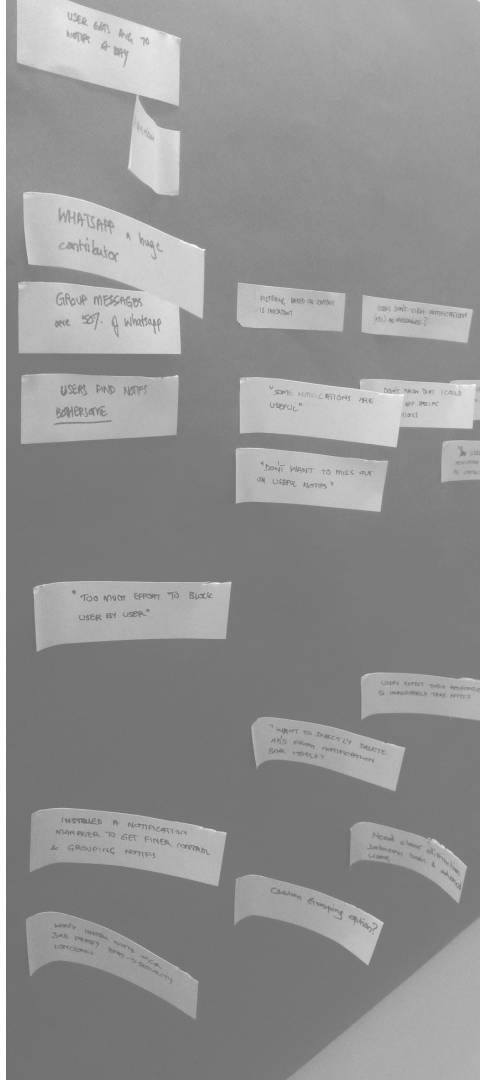
# Design Implications:

- Types of Users:
  - Type 1: Zero Customizer
  - Type 2: Moderate Customizer
  - Type 3: Heavy Customizer
  - Type 4\*: Cluster Blocker



# Design Implications:

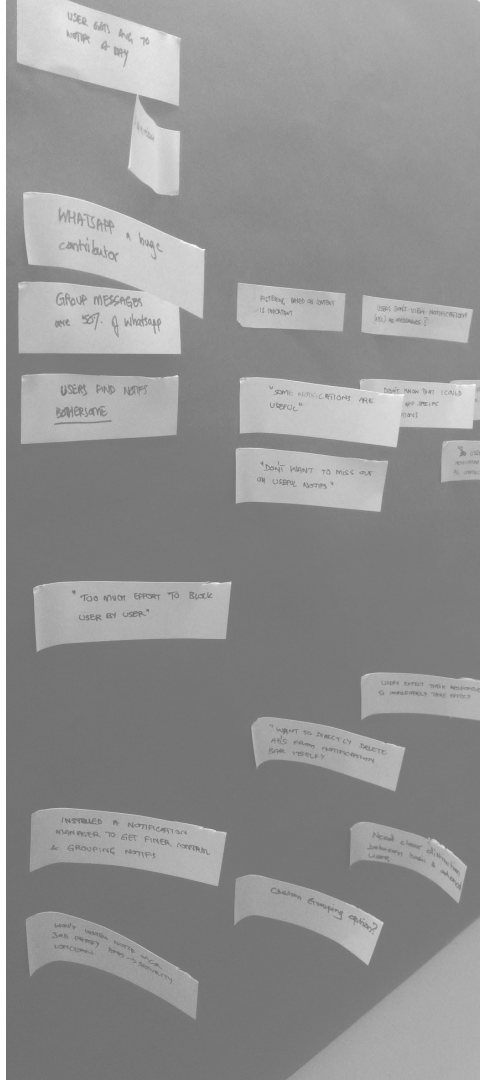
- Types of Users:
  - Type 1: Zero Customizer
  - Type 2: Moderate Customizer
  - Type 3: Heavy Customizer
  - Type 4\*: Cluster Blocker
- **Cater to each user type**





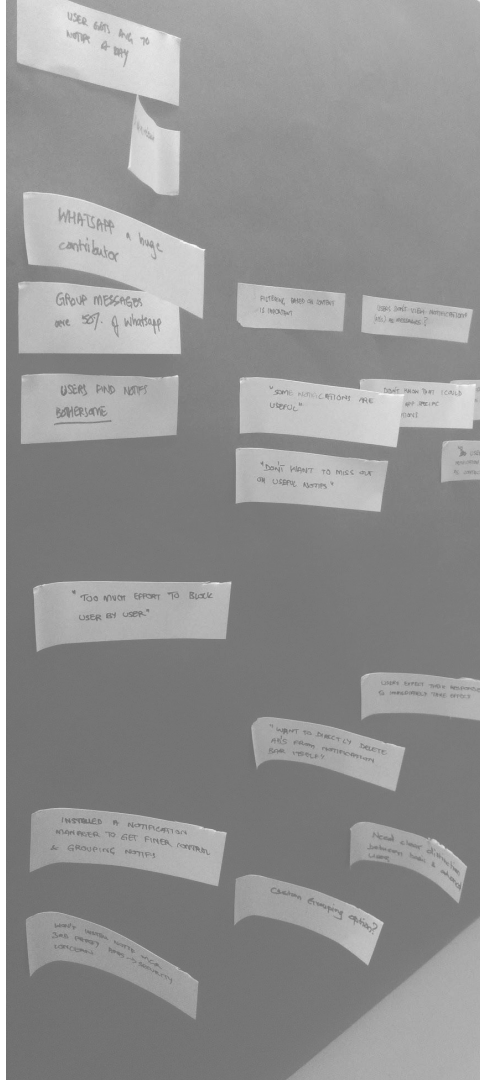
# Design Implications:

- Types of Users:
  - Type 1: Zero Customizer
  - Type 2: Moderate Customizer
  - Type 3: Heavy Customizer
  - Type 4\*: Cluster Blocker
- Cater to each user type
- Filter. Don't block.
- **Prompt Feedback to user actions**
  - People stop using a feature in the absence of visible effect of their actions



# Design Implications:

- Types of Users:
  - Type 1: Zero Customizer
  - Type 2: Moderate Customizer
  - Type 3: Heavy Customizer
  - Type 4\*: Cluster Blocker
- Cater to each user type
- Filter. Don't block.
- Prompt Feedback to user actions
- **Tackle F.o.M.O**





 P3 Defence • Now

---

# Design

Design of system and interactions

 P3 Review • In 7 mins

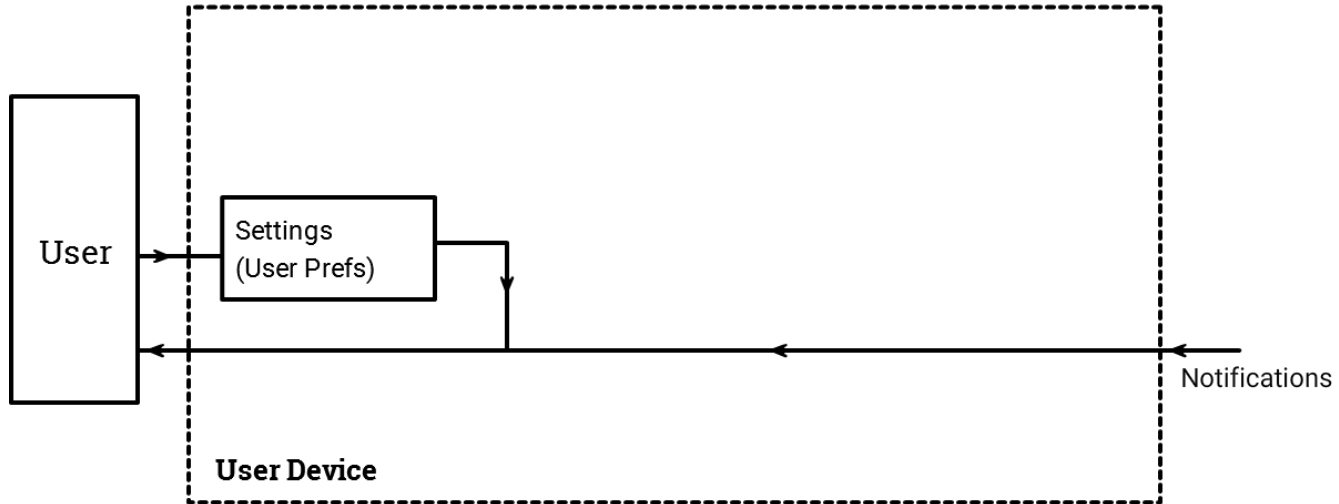
Evaluation

 P3 Review • In 12 mins

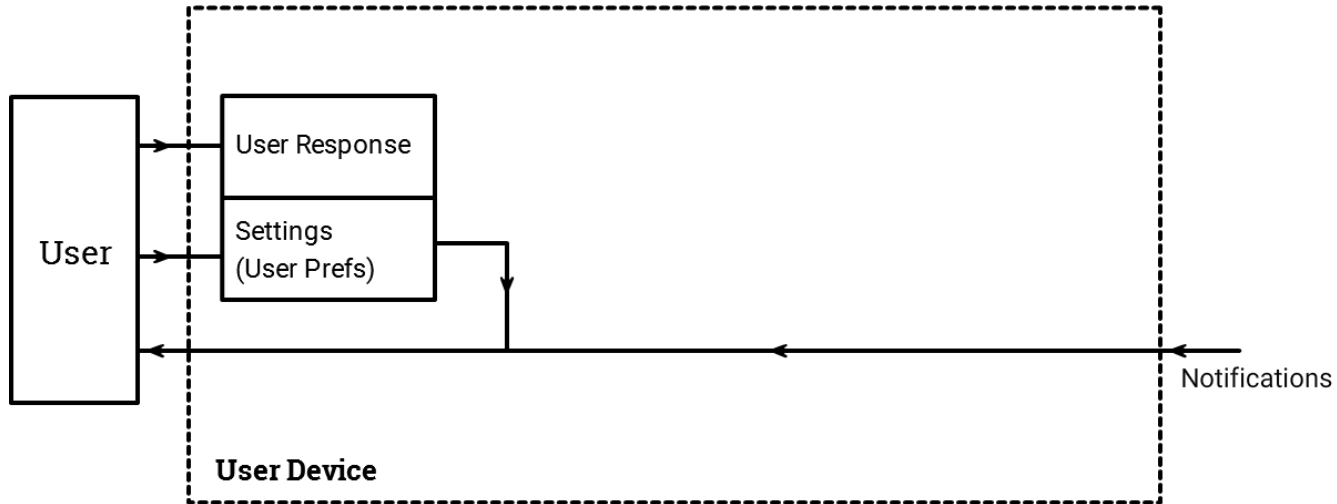
Conclusion

CLEAR ALL

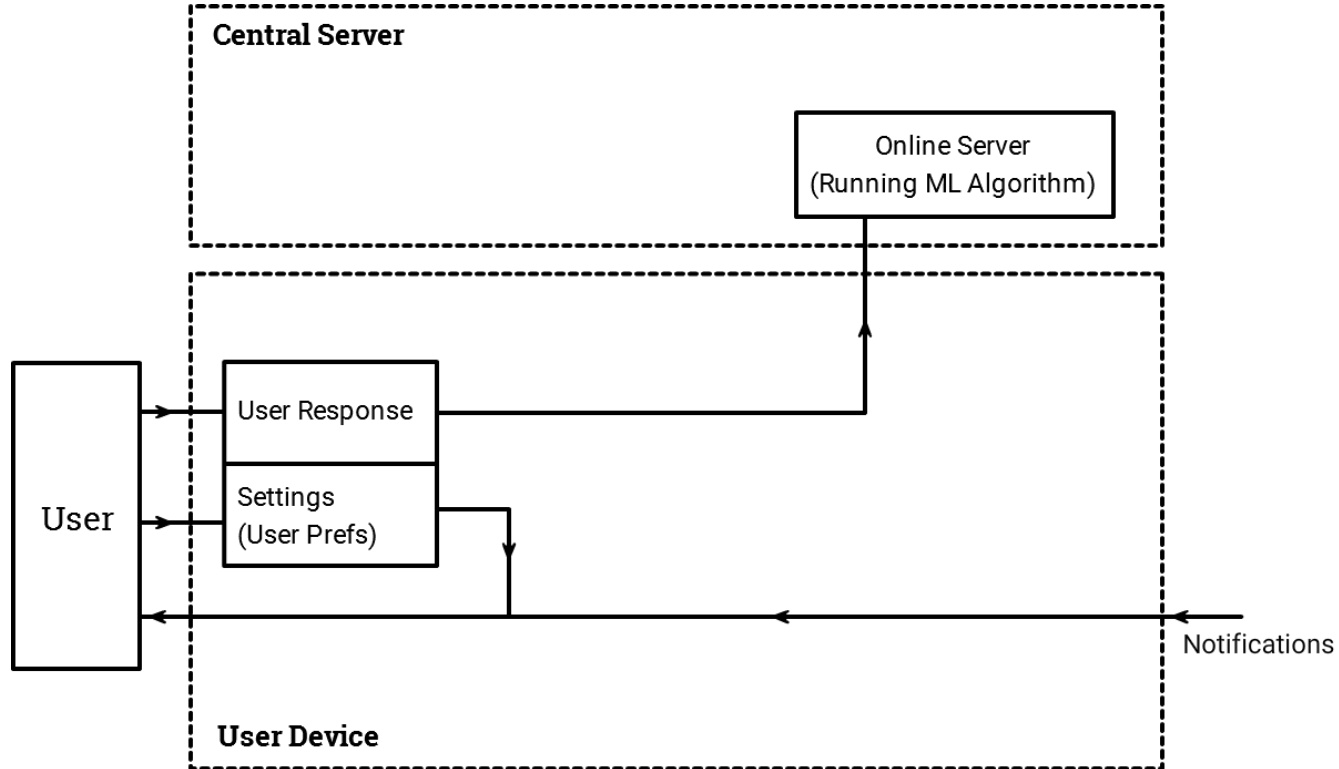
# Design: Current System



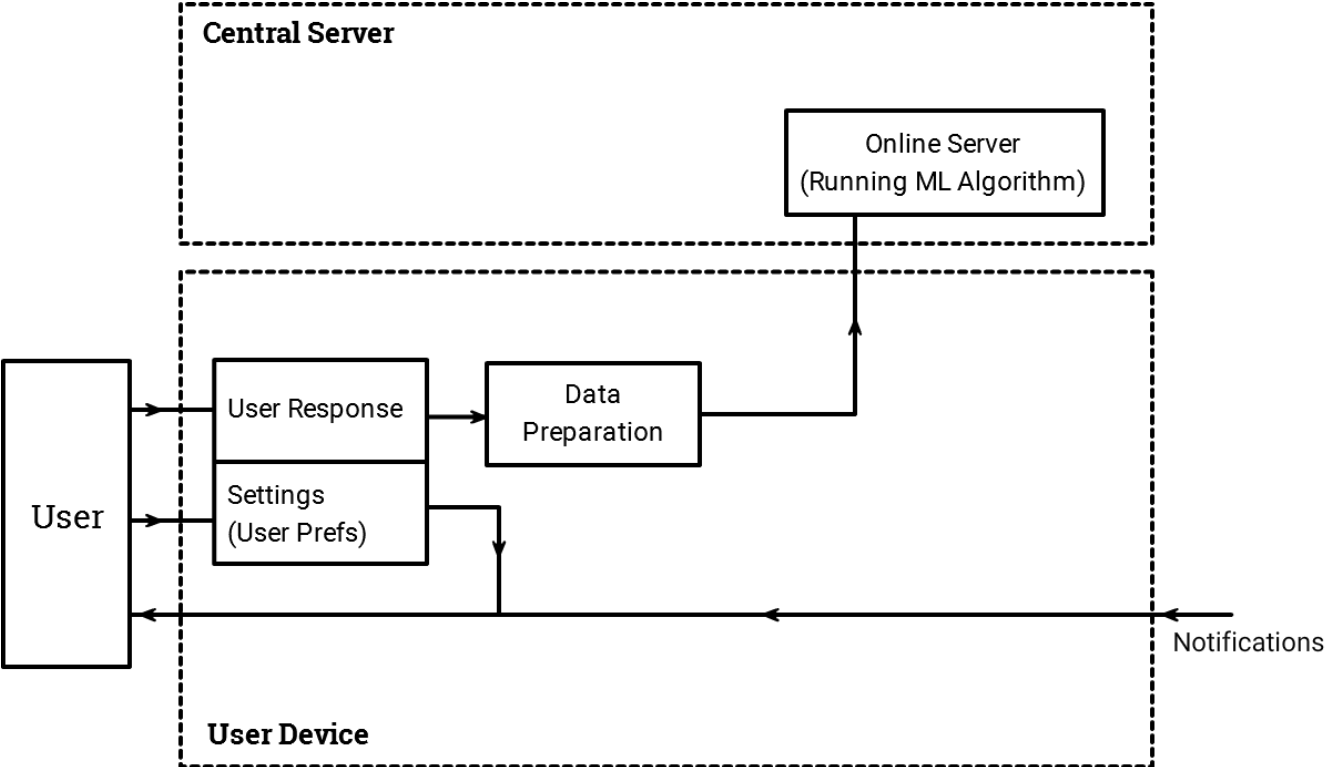
# Design: Proposed System



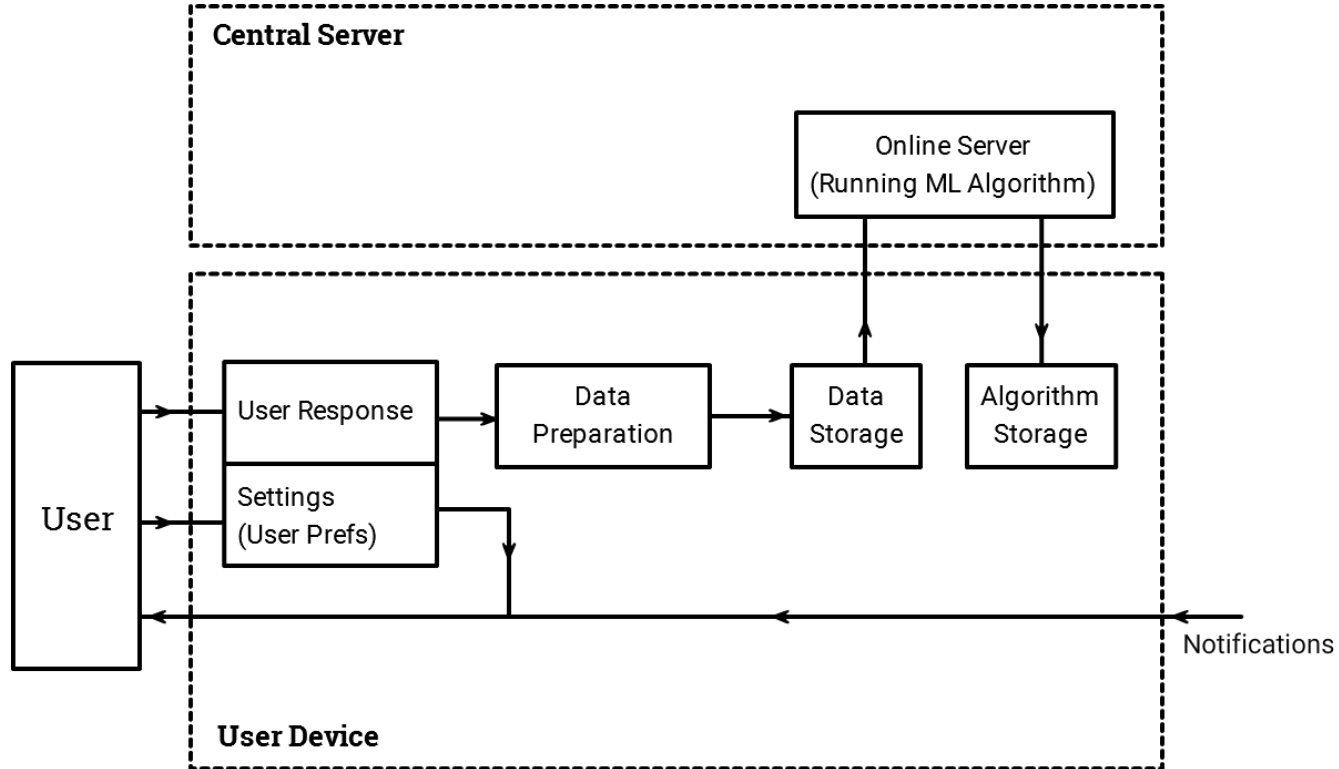
# Design: Proposed System



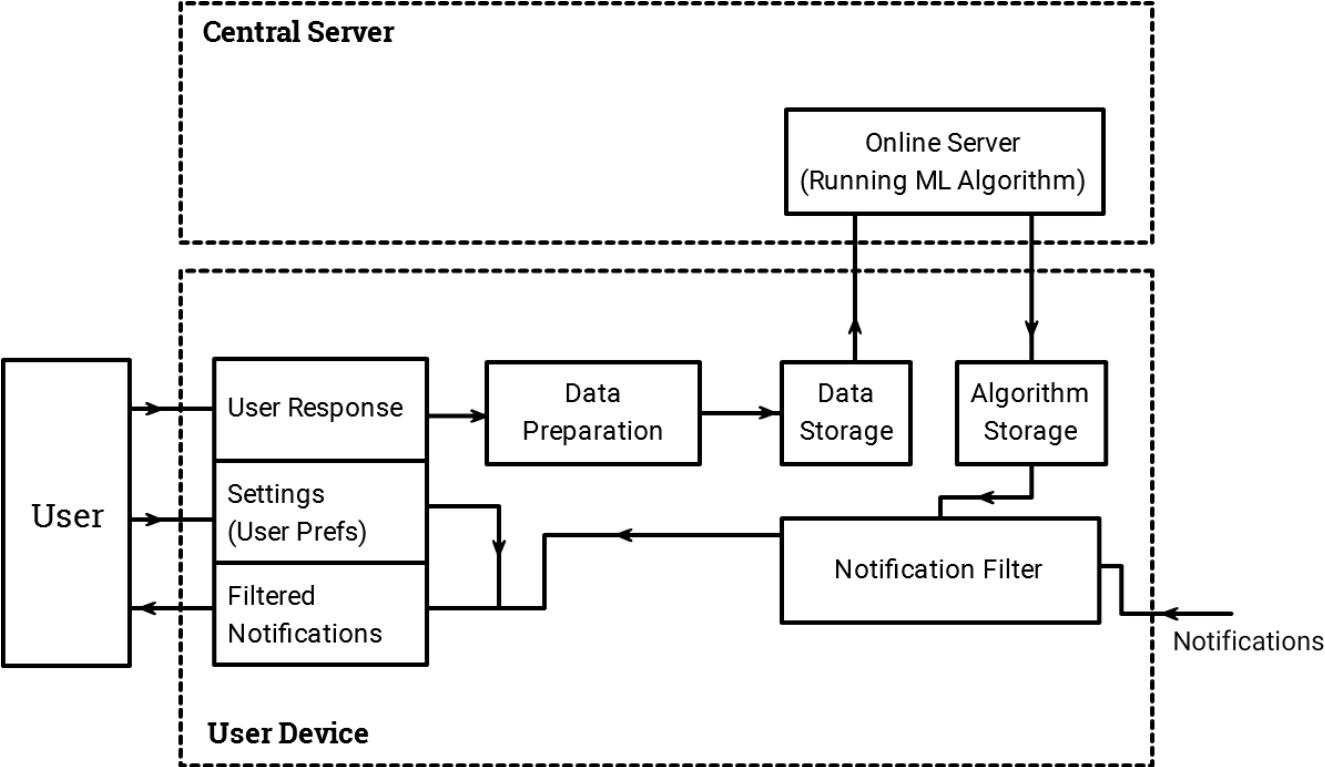
# Design: Proposed System



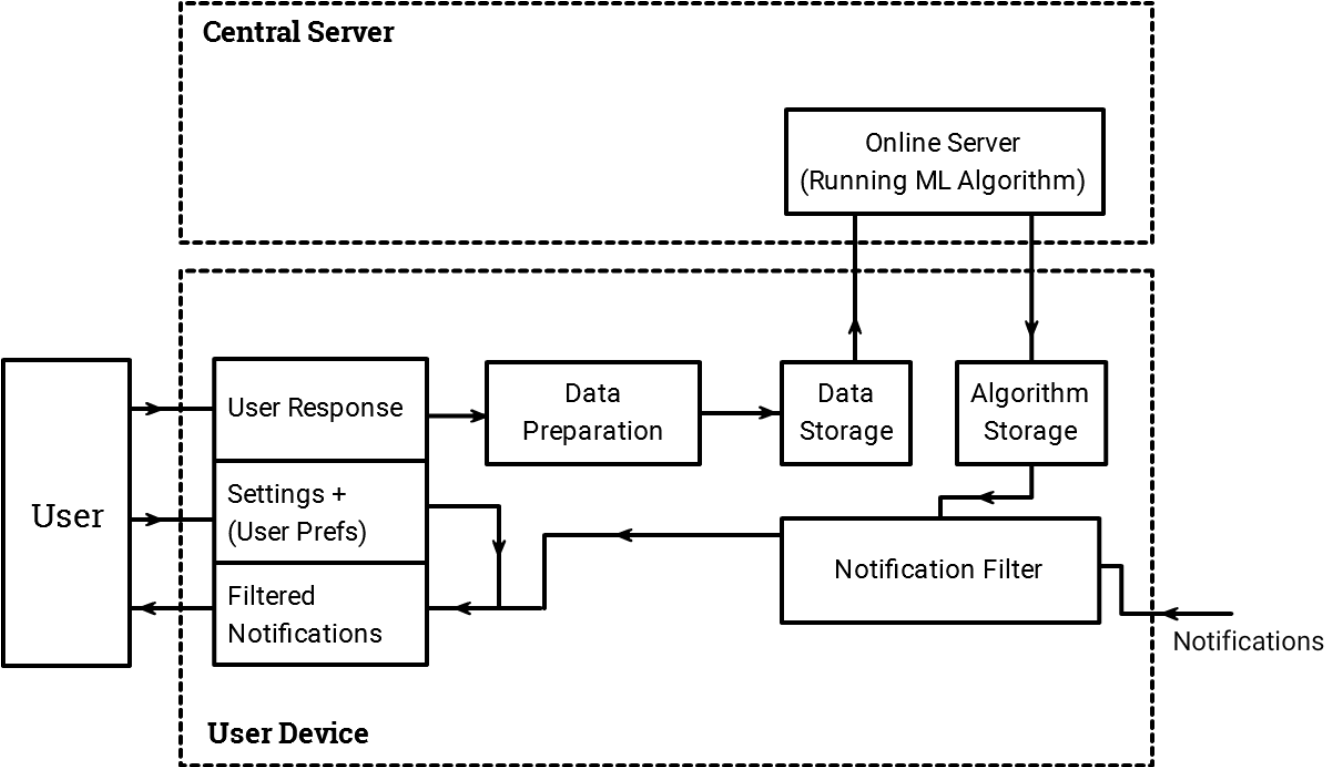
# Design: Proposed System



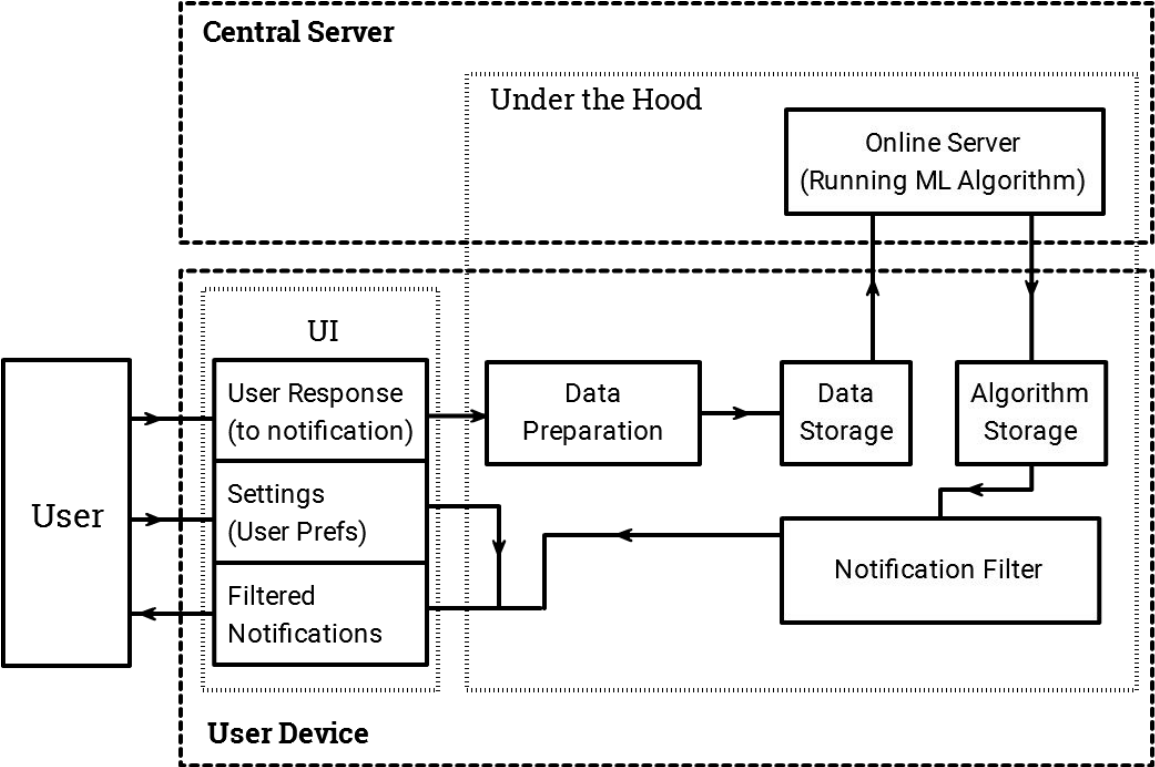
# Design: Proposed System



# Design: Proposed System



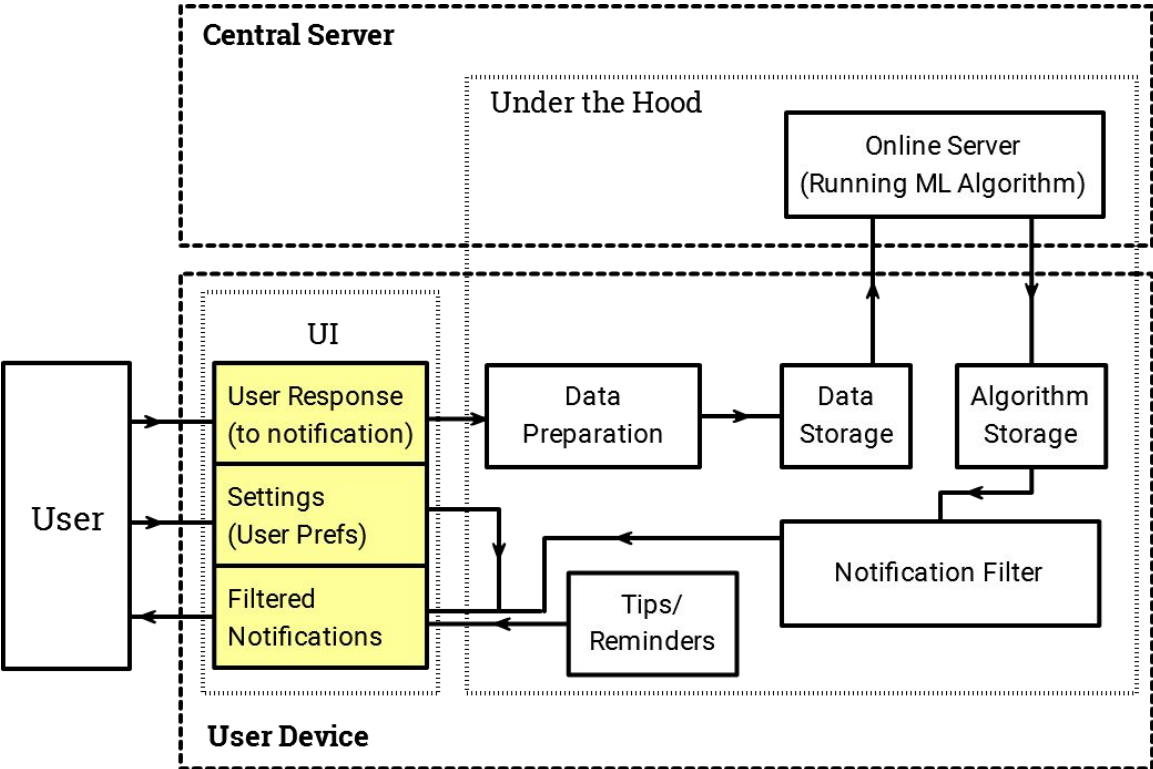
# Design: Overall System



# Design: Prototyping Approach

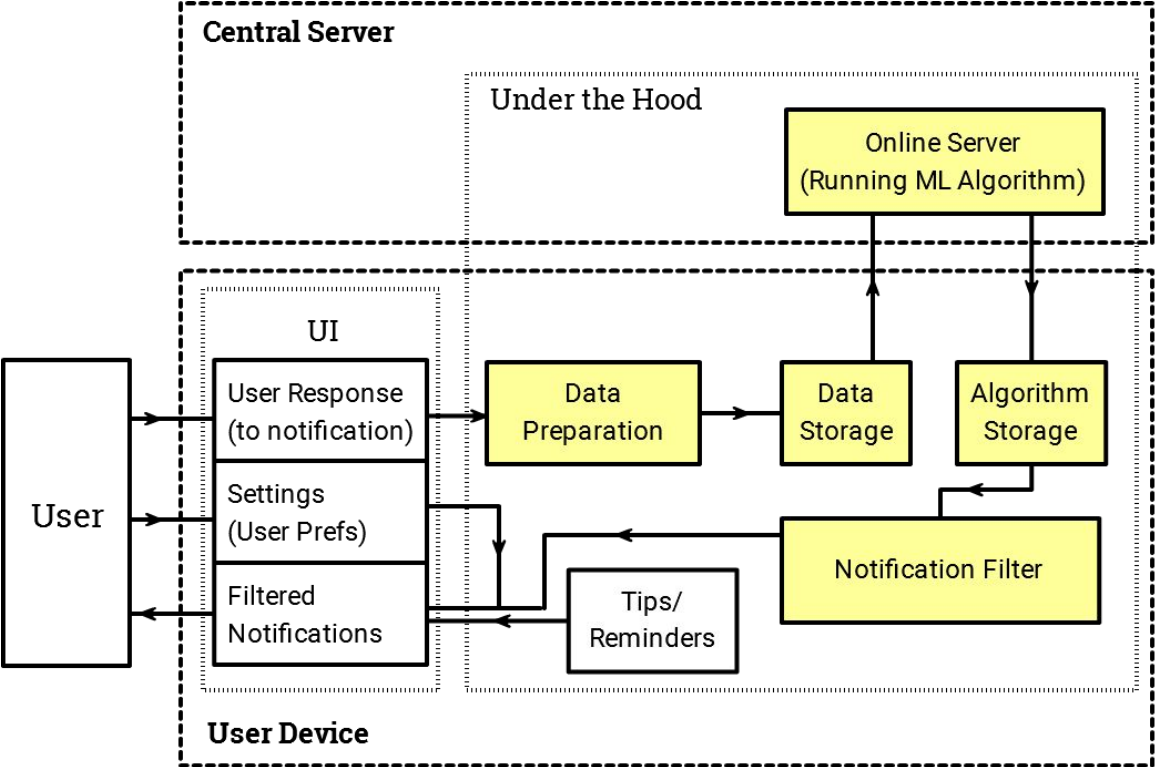
- UI Prototype
  - Demo
  - Due to restrictions on modifying interaction at OS level
- Functioning System Prototype
  - For evaluating performance of system

# Design: Prototyping Approach



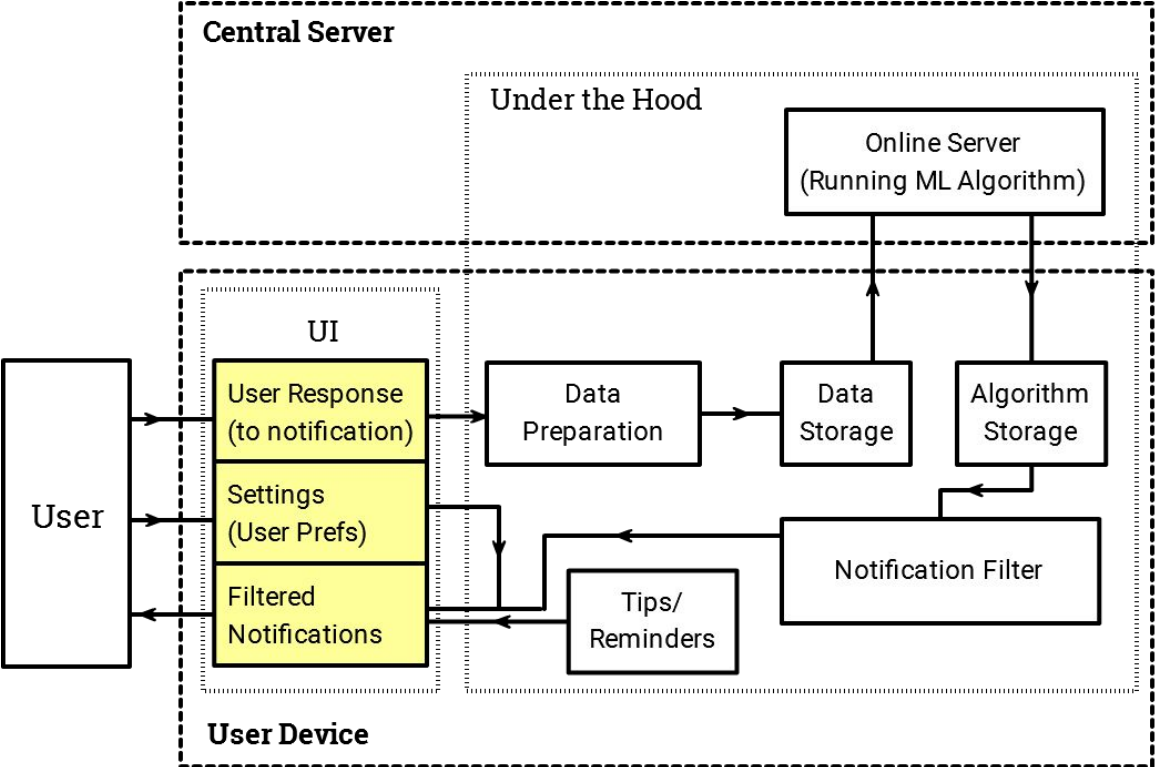
Modules Included in UI Prototype -

# Design: Prototyping Approach



Modules Included in System Prototype - 

# Design: UI



# Design: UI





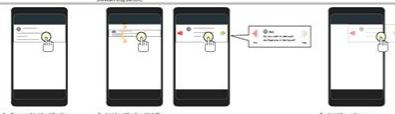
- User Response (Interaction)
- Filtered Notification Presentation
  - Interactions
  - Visuals (Layout and Icon)
- Fine Controls (Flow + Interactions)

# Design - UI: User Response

- Function: Provide user with quick and easy method to communicate their opinion on the relevance of a notification
- Guidelines:
  - Minimum no. of actions
  - Minimum Cognitive Load




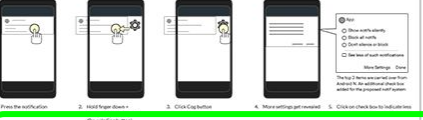

# Design - UI: User Response : Ideation

- Function: Provide user with quick and easy method to communicate their opinion on the relevance of a notification
- Guidelines:
  - Minimum no. of actions
  - Minimum Cognitive Load

INTERACTION	EFFORT	COGNITIVE LOAD <i>(indicative)</i>
 <p>1. Press and hold the notification 2. More settings per message 3. Click on check box to indicate less relevance + Click Done button</p>	Moderate (3.5)	High
 <p>1. Press the notification 2. Hold finger down + Drag right to include low-relevance 3. Hold finger down + Drag right to include high-relevance</p>	Low (1.5)	High
 <p>1. Press the notification 2. Hold finger down + Hold/Click 3. Press notification 4. Swipe down to reveal response buttons 5. Click response button to include high-relevance</p>	High (4.5)	Low
 <p>1. Press the notification 2. Hold finger down + Short-tap on right (showing a gear icon) 3. Click Done button 4. More settings per message 5. Click on check box to indicate less relevance + Click Done button</p>	High (4.5)	High
 <p>1. Press and hold notification 2. Hold notification in 180° (showing a feedback icon) 3. Hold finger down + Tap on right (to include high-relevance)</p>	Low (2)	Low

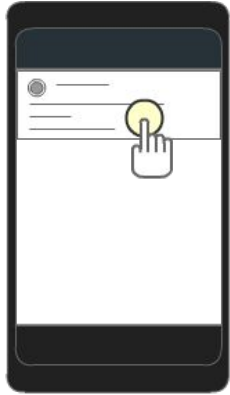
# Design - UI: User Response : Ideation

- Function: Provide user with quick and easy method to communicate their opinion on the relevance of a notification
- Guidelines:
  - Minimum no. of actions
  - Minimum Cognitive Load

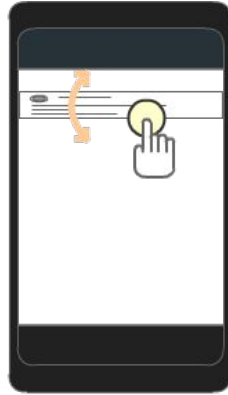
INTERACTION	EFFORT	COGNITIVE LOAD <i>(indicative)</i>
 <p>1. Press and hold the notification 2. More settings per message 3. Click on check box to indicate less relevance - Click Done button</p>	Moderate (3.5)	High
 <p>1. Press the notification 2. Hold Right down + Drag right to include low relevance 3. Hold Right down + Drag right to include high relevance</p>	Low (1.5)	High
 <p>1. Press the notification 2. Hold Right down + Hold/Click - Exclude notification 3. Press notification 4. Swipe down to reveal response buttons 5. Click Response button to include high/low relevance</p>	High (4.5)	Low
 <p>1. Press the notification 2. Hold Right down + Hold/Click - Show settings 3. Click Done button 4. More settings per message 5. Click on Check box to indicate less relevance</p>	High (4.5)	High
 <p>1. Press and hold notification 2. Tap notification to show notification feedback 3. Tap notification to show notification feedback 4. Hold Right down - Reveal right to left to include</p>	Low (2)	Low

# Design - UI: User Response

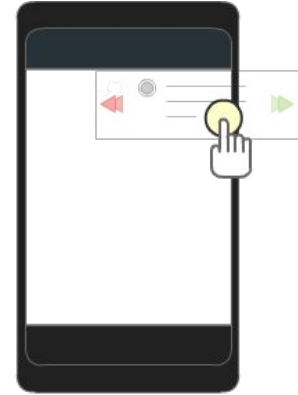
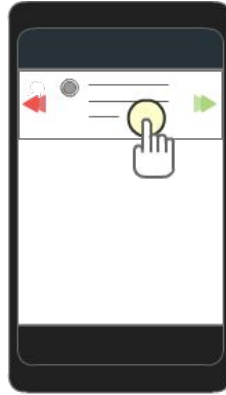
- Selected Interaction: Based on **effort** and **cognitive load** on user



1. Press and hold notification



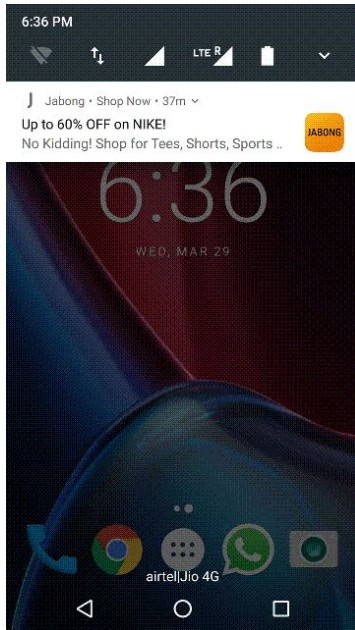
2. Hold notification till it flips  
(Vibration feedback)



3. Hold finger down +  
Swipe right or left to indicate  
high/low relevance

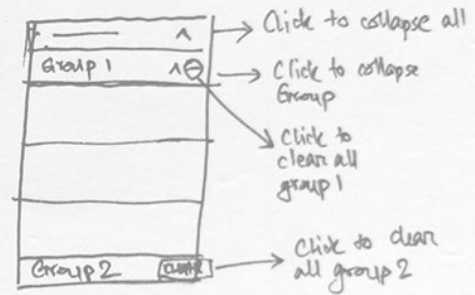
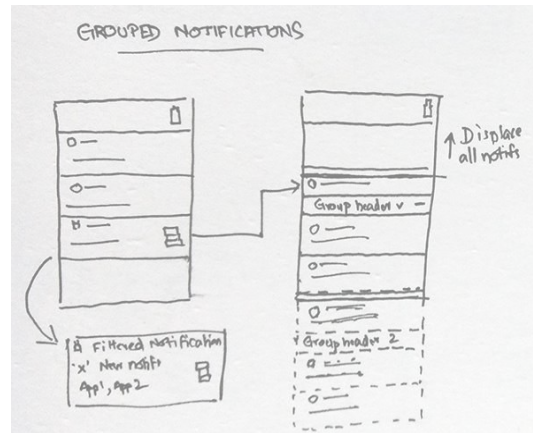
# Design - UI: User Response

- Selected Interaction



# Design - UI: Presentation

- Potentially >40 notifications per day
  - Grouping for easier consumption
- On notification bar over separate screen
  - To maintain user conceptual models
- Flow designed and screens wireframed

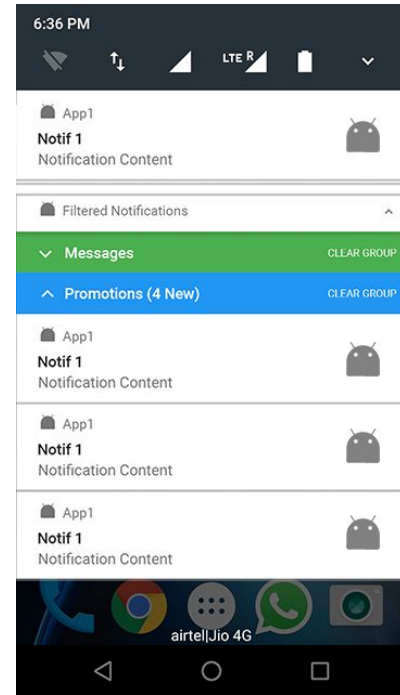
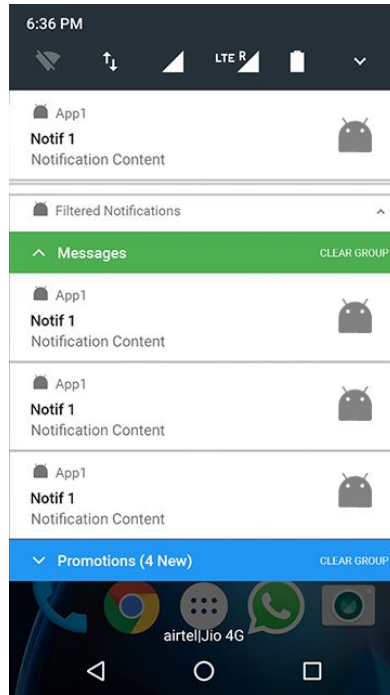
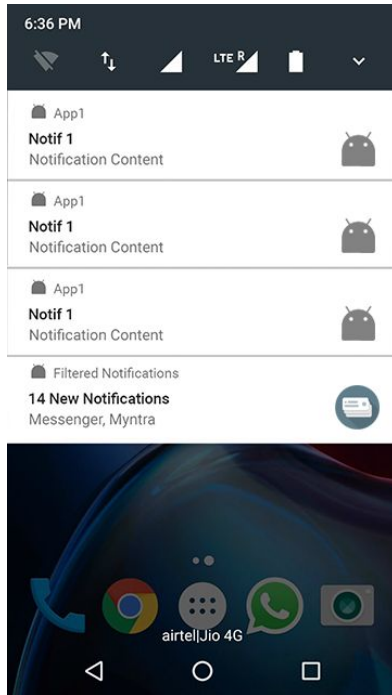


# Design - UI: Presentation

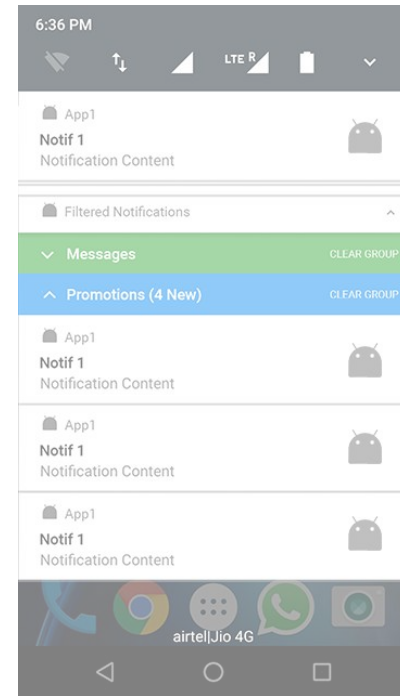
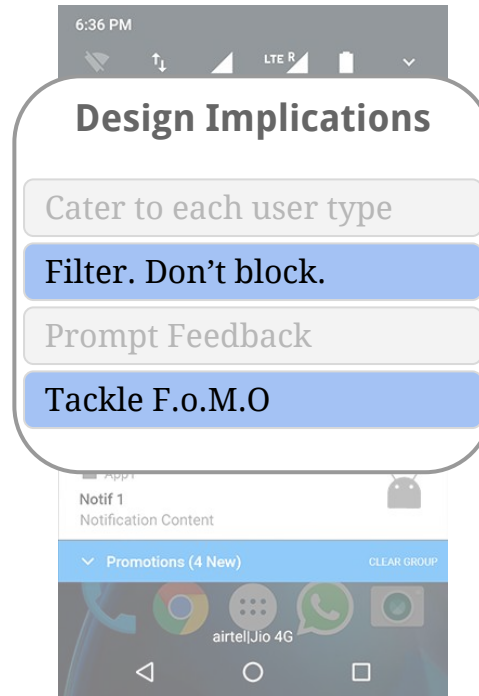
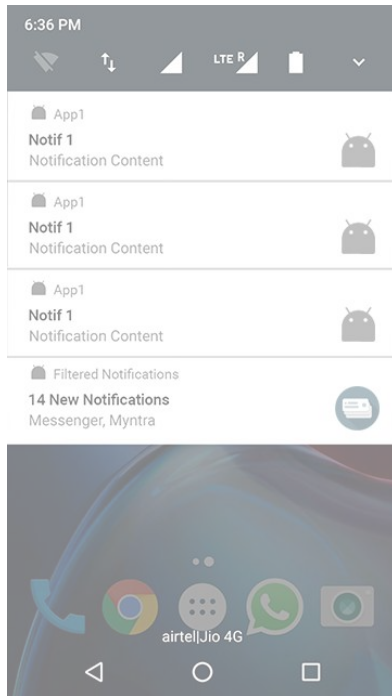
- Icon Designed for “filtered+grouped” notification



# Design - UI: Presentation



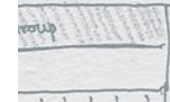
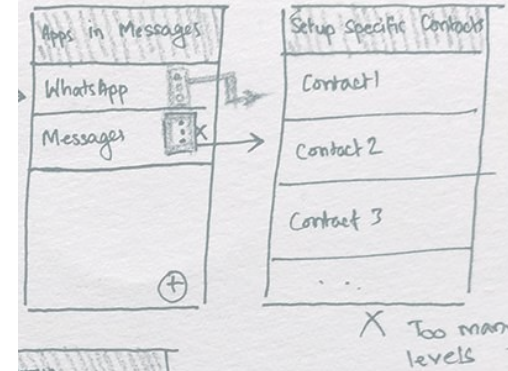
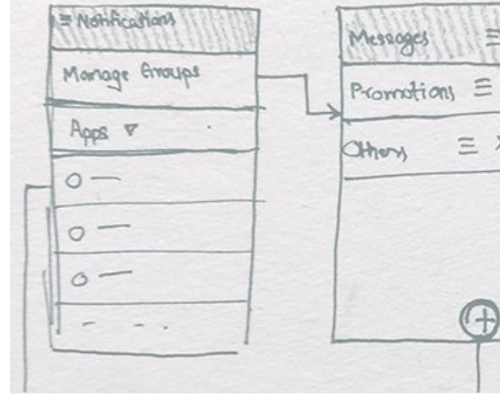
# Design - UI: Presentation



# Design - UI: Fine Controls

- Guidelines:
  - New options shouldn't clash with existing conceptual model of users
  - Provide user with means to tweak filtering to the last detail

ON SETTINGS



# Design - UI: Fine Controls

- Guidelines:
  - New options shouldn't clash with existing conceptual model of users
  - Provide user with means to tweak filtering to the last detail

ON SETTINGS



## Design Implications

Cater to each user type

Filter. Don't block.

Prompt Feedback

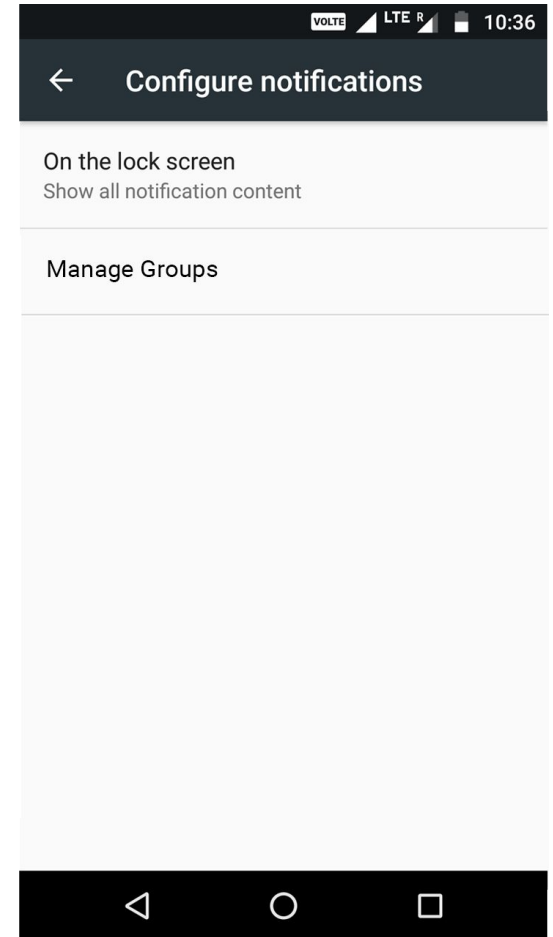
Tackle F.o.M.O



X Too many levels

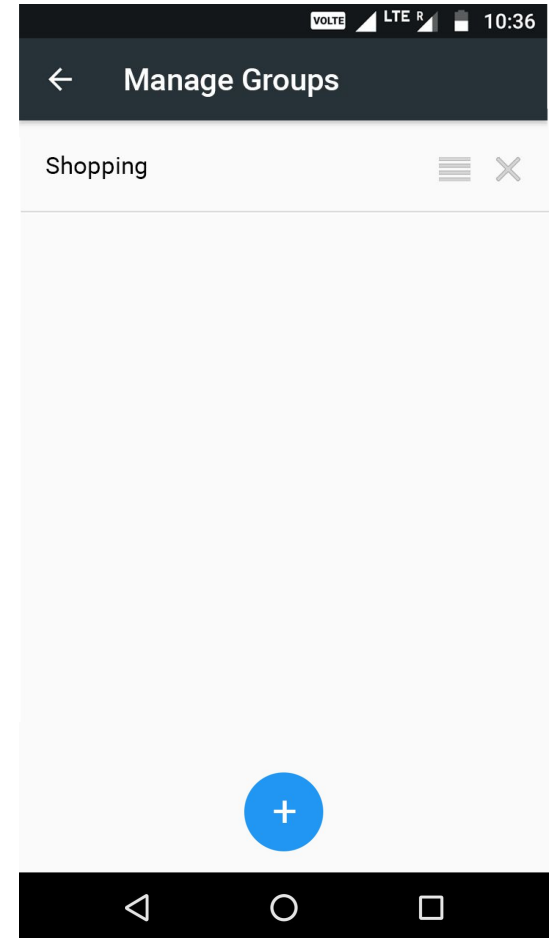
# Design - UI: Fine Controls

- Customization options:
  - **Managing Groups**
    - Targeting Type 2 & 3 users



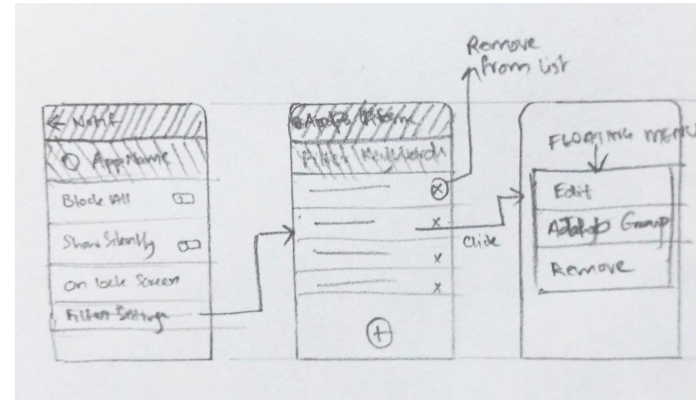
# Design - UI: Fine Controls

- Customization options:
  - **Managing Groups**
    - Targeting Type 2 & 3 users



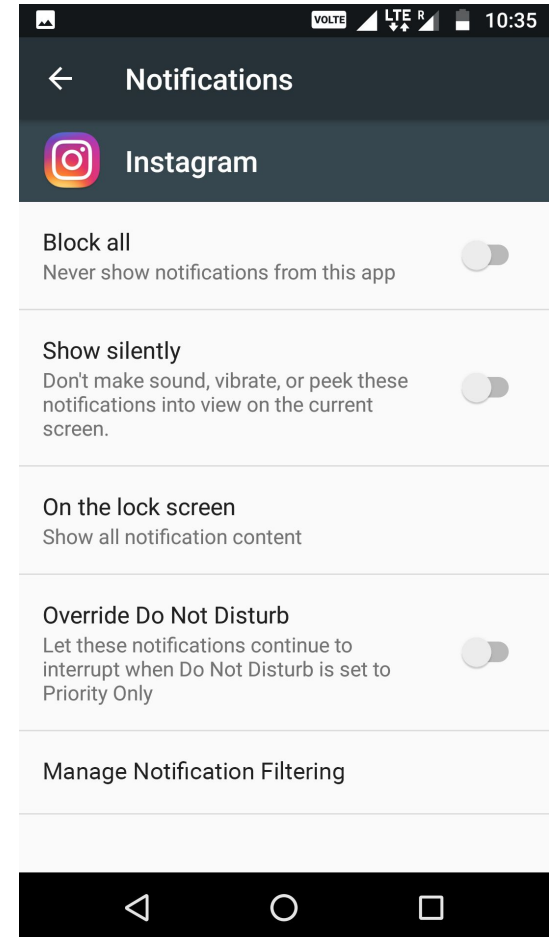
# Design - UI: Fine Controls

- Customization options:
  - Managing Groups
  - **Controlling the filter keywords**
    - For Expert users (Type 3 users)



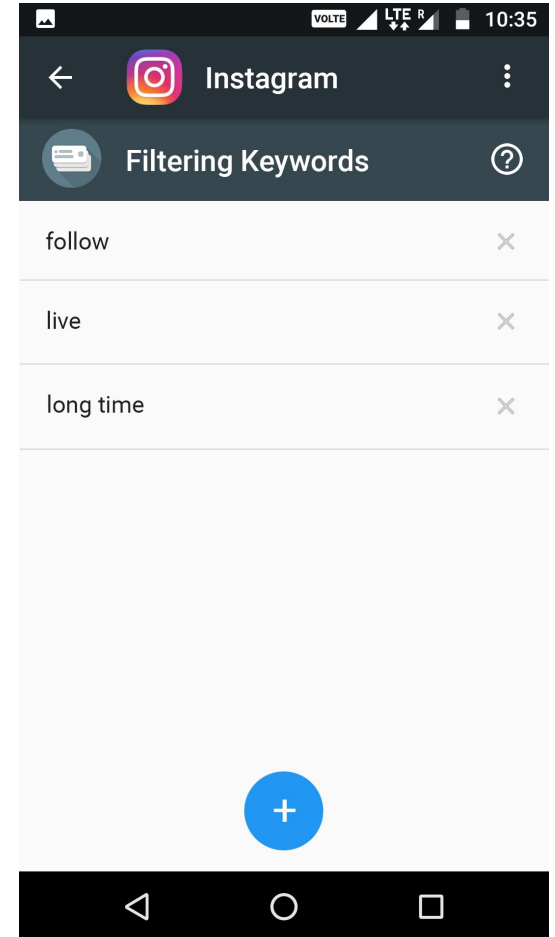
# Design - UI: Fine Controls

- Customization options:
  - Managing Groups
  - **Controlling the filter keywords**
    - For Expert users (Type 3 users)



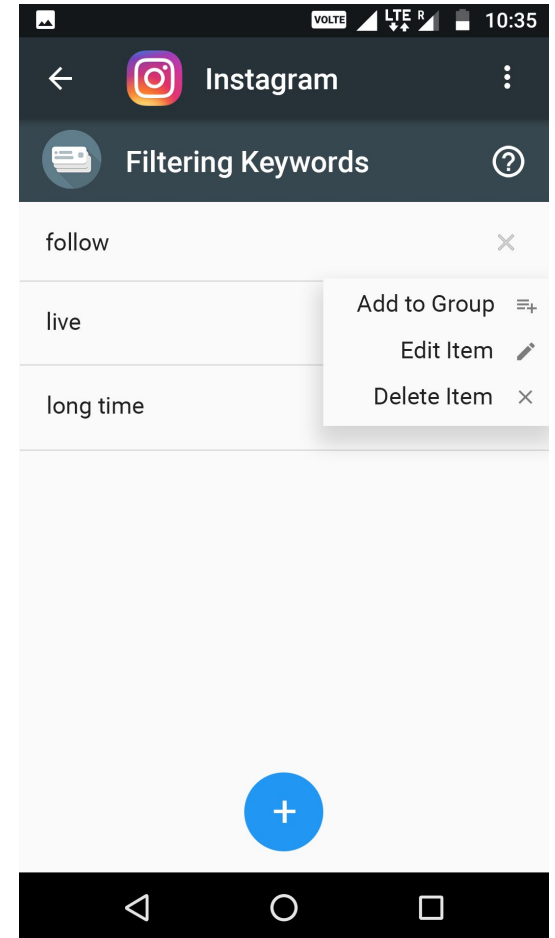
# Design - UI: Fine Controls

- Customization options:
  - Managing Groups
  - **Controlling the filter keywords**
    - For Expert users (Type 3 users)

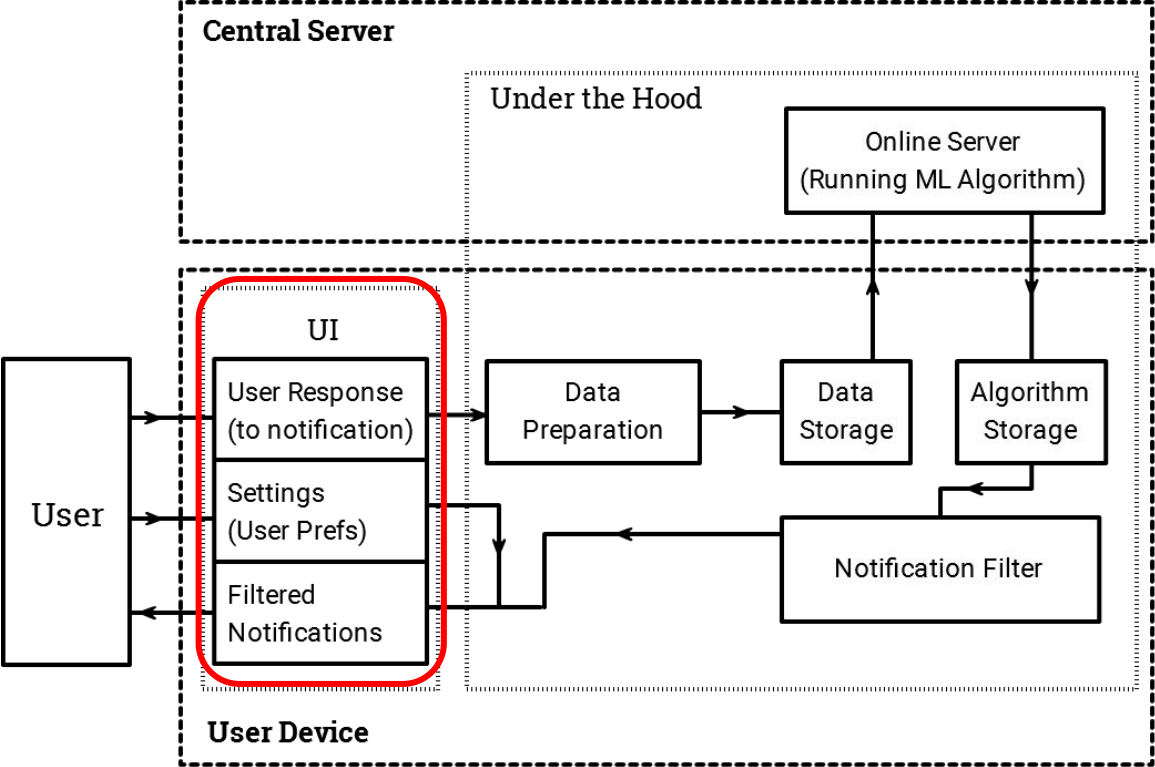


# Design - UI: Fine Controls

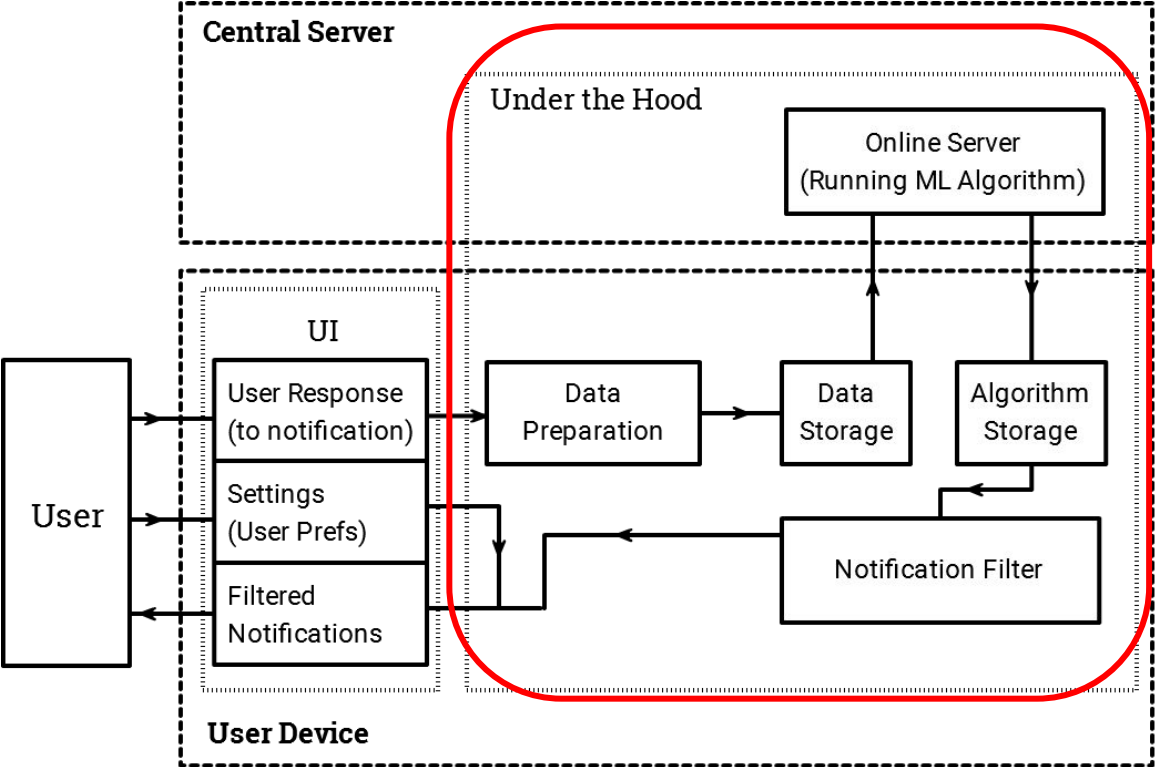
- Customization options:
  - Managing Groups
  - **Controlling the filter keywords**
    - For Expert users (Type 3 users)



# Design: UI



# Design: System



# Design - System: Data Preparation

- Selection of variables to track
  - Should capture essence of user preferences

## SELECTED VARIABLES

- App/Package Name
- Date of receipt
- Time of Receipt
- Time of Consumption
- Priority of message
- Text Content of the notification
- Title of notification
- User response

# Design - System: Data Storage

- Guidelines
  - Quell Data Security concerns
  - Data (internet) Usage Minimization

```
boolean foundTitle = false;
for (int chkCount = 0; chkCount < titleArray.length; chkCount++)
//For checking if its a group message or whatsapp message
if (title.contains(titleArray[chkCount]) && title.length > 1)
//if group message, then it wont start with the con
if (title.startsWith(titleArray[chkCount])) {
    title = String.valueOf(chkCount);
    foundTitle = true;
    break;
} else {
    title = title.split(titleArray[chkCount])[0].trim();
}
}

if (titleArray[chkCount].contains(title) && title.length > 1)
titleArray[chkCount] = title;
titleText = titleText.replace(titleArray[chkCount],
SharedPreferences.Editor edit = sharedPref.edit();
edit.putString("titleList", titleText);
edit.apply();

title = String.valueOf(chkCount);
foundTitle = true;
break;
}

if (title.equals(titleArray[chkCount])) {
    title = String.valueOf(chkCount);
    foundTitle = true;
    break;
}
}

if (!foundTitle) {
    titleText = titleText + "," + title;
    SharedPreferences.Editor editor = sharedPref.edit();
    editor.putString("titleList", titleText);
    editor.apply();

    titleArray = titleText.split(",");
    title = String.valueOf(titleArray.length - 1);
}

Log.e("Title", title);

//Get appname and convert into item in array
String appName = GetAppName(sbn.getPackageName());
boolean foundApp = false;
```

# Design - System: Data Storage

- Guidelines
  - Quell Data Security concerns
  - Data (internet) Usage Minimization

```
boolean roundTitle = false;  
for (int chkCount = 0; chkCount < titleArray.length; chkCou  
//For checking if its a group message or whatsapp messa
```

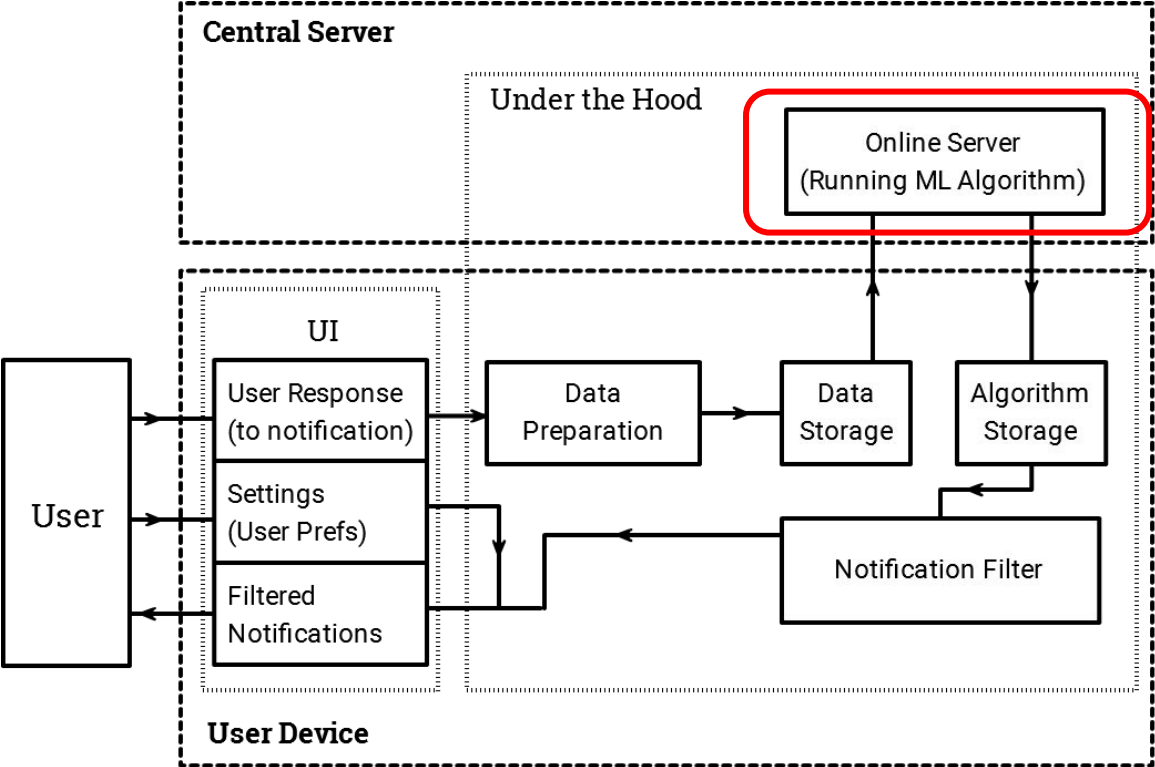
4804

```
Id: 134686532  
app_name: "Gmail"  
bundle_keyset: "Bundle{ android.title =>  
cancellable: "1"  
category: "email"  
date_d: 22  
date_m: 3  
date_y: 2017  
day_of_week: 4  
flags: 16  
ongoing: "0"  
package: "com.google.android.g  
priority: 0  
response: "1"  
status: "remove"  
text: "IDC Wednesday Film Screenin  
ticker: "NA"  
time: 68166  
title: "S.Gnana Selvar
```

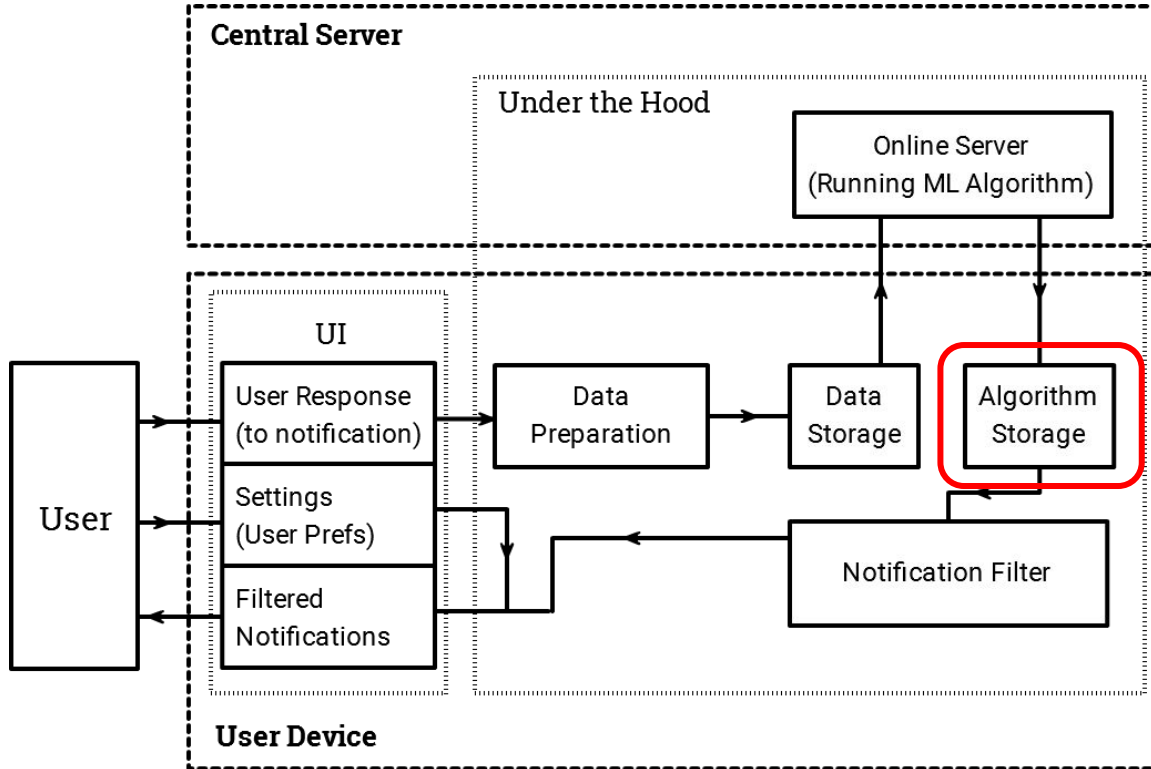
```
String appName = getAppName(sbn.getPackageName());  
boolean foundation = false;
```



# Design - System: Online Server

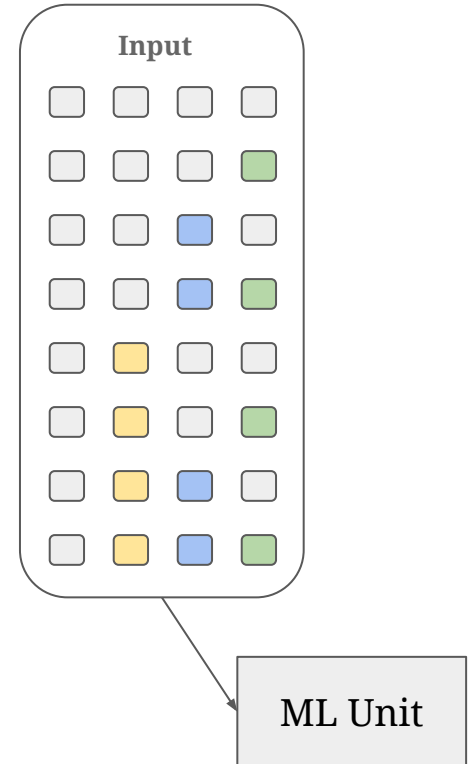


# Design - System: Algorithm Export



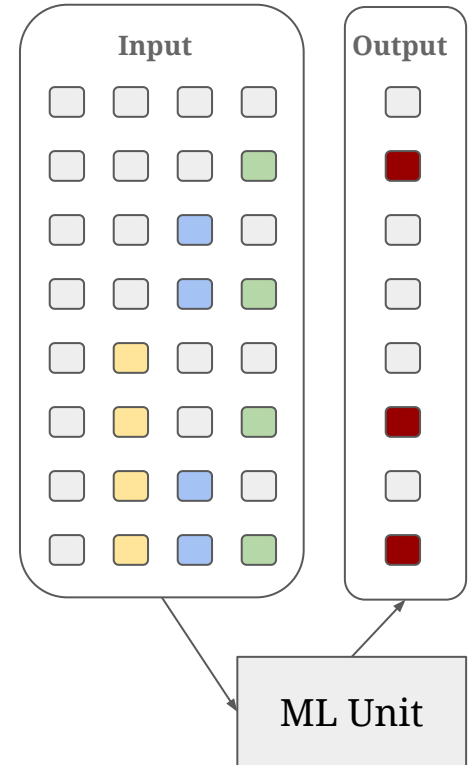
# Design - System: Algorithm Export

- User not always online
  - Need to have filtering occur within user device
- Method:
  - All possible permutations of features fed into algorithm



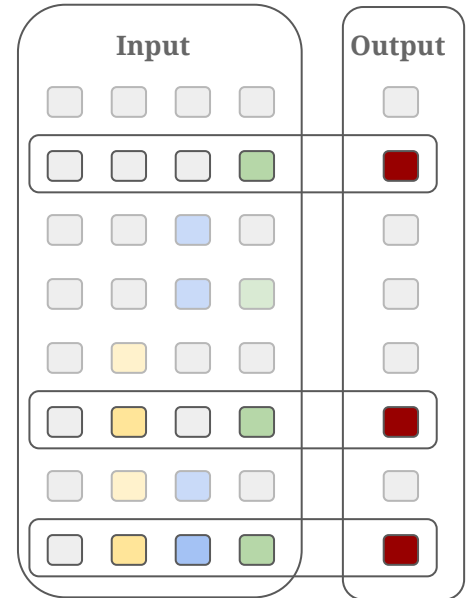
# Design - System: Algorithm Export

- User not always online
  - Need to have filtering occur within user device
- Method:
  - All possible permutations of features fed into algorithm
  - Permutations that are marked irrelevant are extracted & exported to user device



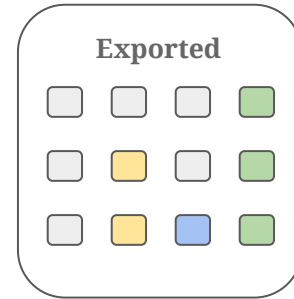
# Design - System: Algorithm Export

- User not always online
  - Need to have filtering occur within user device
- Method:
  - All possible permutations of features fed into algorithm
  - Permutations that are marked irrelevant are extracted & exported to user device

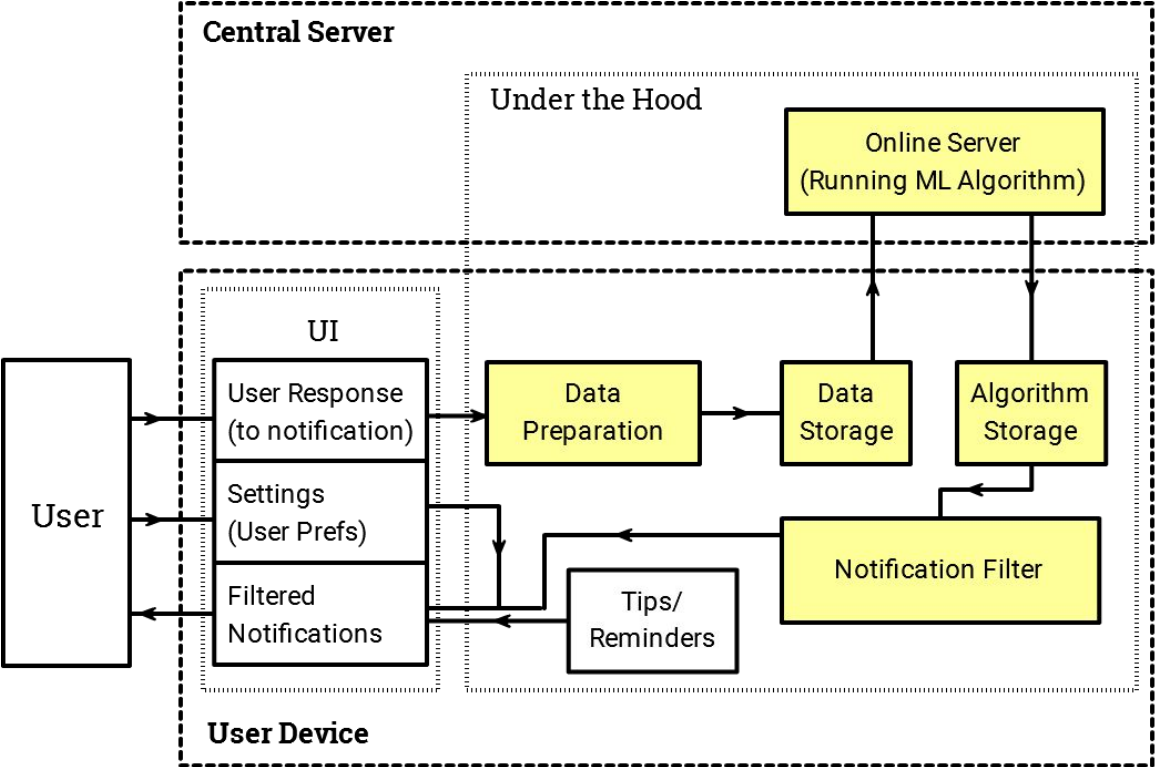



# Design - System: Algorithm Export

- User not always online
  - Need to have filtering occur within user device
- Method:
  - All possible permutations of features fed into algorithm
  - Permutations that are marked irrelevant are extracted & exported to user device



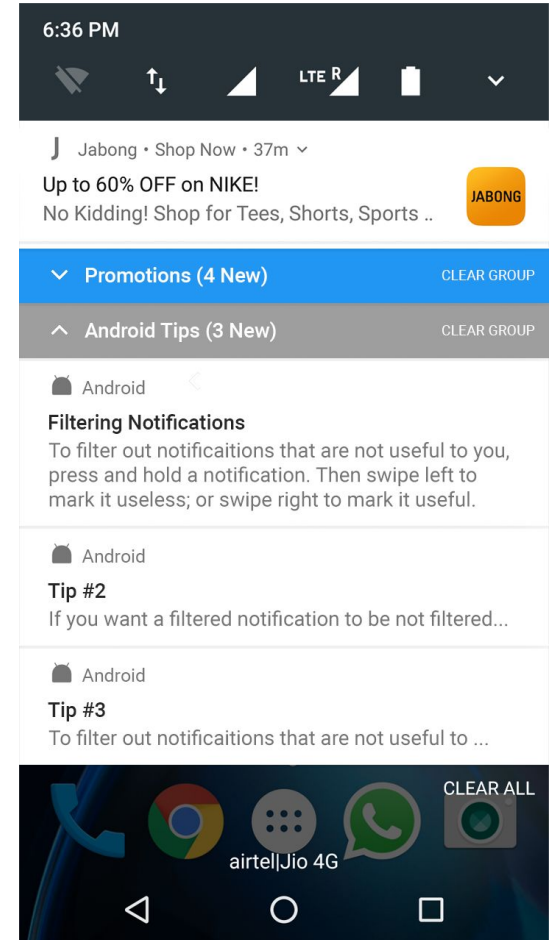
# Design: System Prototype



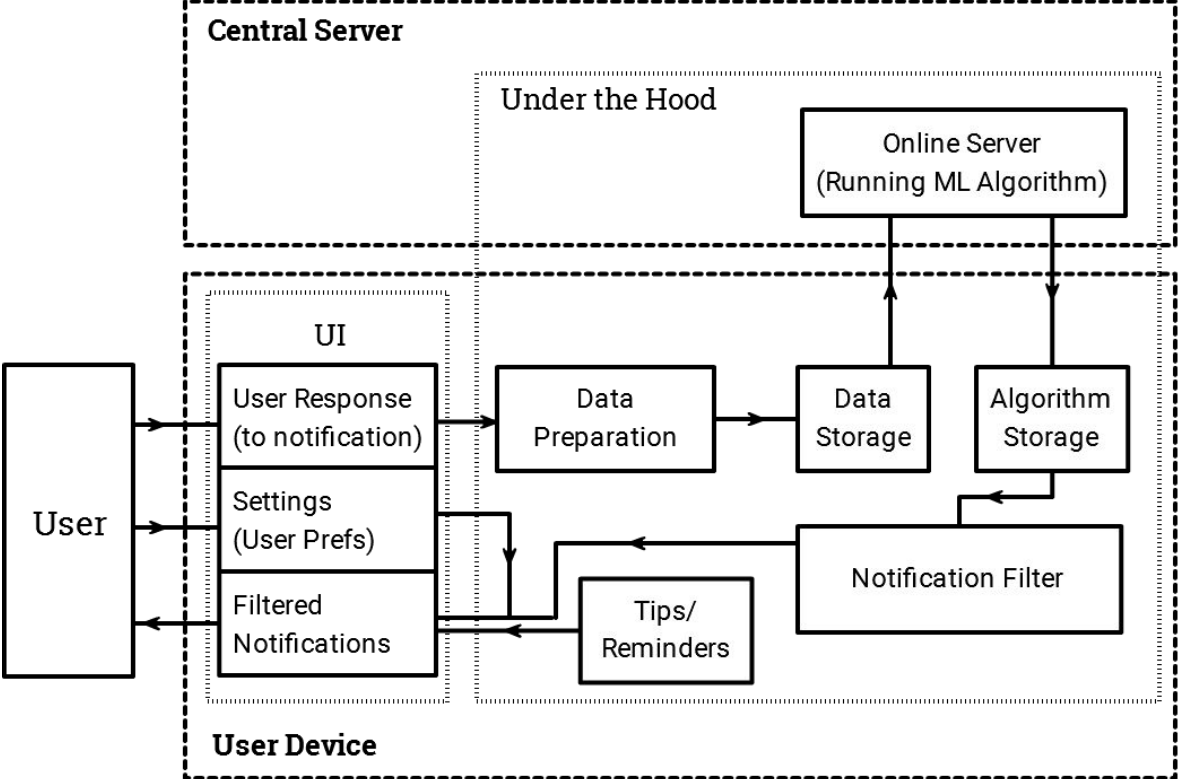
Modules Included in System Prototype - 

# Design: Reminders/Tips

- Help user utilize features in android
- Based on user behaviour
  - Usage frequency of feature



# Design: Reminders/Tips



# Design: Delayed Delivery

- Timings such that there is minimum break in flow for user
- Possible options:
  - a. At a specific time of day
    - Based on initial usage behaviour
  - b. Just after a phone call
  - c. Just after user quits an app
    - Specifically leisure apps

 P3 Defence • Now

---

# Evaluation

Design & Evaluation of Algorithm

 P3 Review • In 5 mins

Conclusion

 P3 Review • In 7 mins

Thank You



# Evaluation: Key Metrics

- % of irrelevant messages filtered
  - Directly feeds into aim of the project (Reduce no.of interruptions)
- % of Relevant messages filtered(incorrectly)
  - Should be minimum
- Number of filtered items with low number of data points
  - Initial stages of use

The image shows a Python IDE window with a file named 'earning\_data\_structuring.py'. The code includes conditional logic for setting values in a list: `data_features.iat[i,3] = 4`, `data_features.iat[i,3] = 3`, `data_features.iat[i,3]`, and `data_features.iat[i,3]`. A callout box titled 'Design Implications' is overlaid on the code, containing four items: 'Cater to each user type', 'Filter. Don't block.', 'Prompt Feedback', and 'Tackle F.o.M.O'. Below the callout, more code is visible, including `data_features['title']:`, `(z in title_matrix):`, `data_features.iat[i,1] = title_`, `title_matrix.append(z)`, `data_features.iat[i,1] = title_`, and `data_in2['app_name']`.

## Design Implications

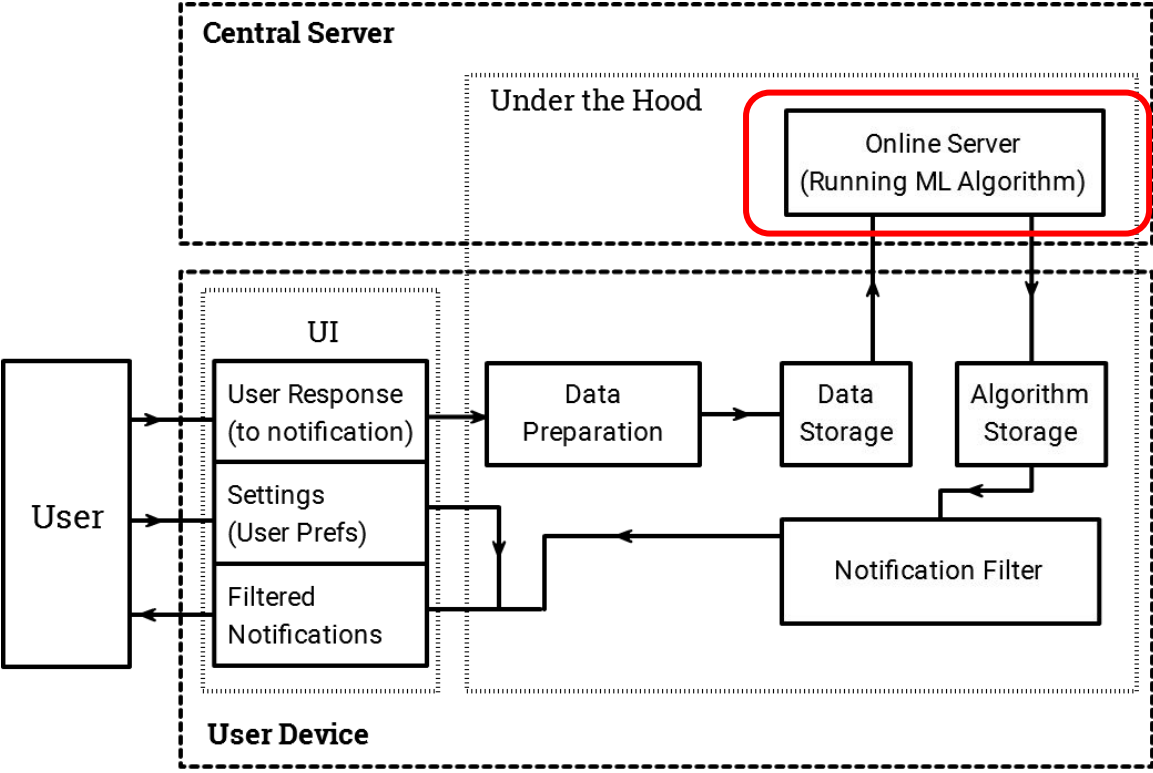
Cater to each user type

Filter. Don't block.

Prompt Feedback

Tackle F.o.M.O

# Design/Evaluation: Algorithm



# Design/Evaluation: Algorithm

- Iterative (design/evaluation) process

# Design/Evaluation: Algorithm

- Development Details
  - Platform: Python
  - Scikit Learn ML Library



# Design/Evaluation: Algorithm

- Main sections of filtering algorithm
  - Data prep
  - ML Method Selection
  - ML Algorithm Export

# Design/Evaluation: Algorithm

- Main sections of filtering algorithm
  - Data prep
  - **ML Method Selection**
  - ML Algorithm Export

# Design/Evaluation: Algorithm

- Guideline:
  - **No relevant message should be filtered**
    - Else, user builds a habit of checking filtered messages regularly (F.o.M.O)
  - **User should see prompt effect(filtering)**

## Design Implications

Cater to each user type

Filter. Don't block.

**Prompt Feedback**

**Tackle F.o.M.O**

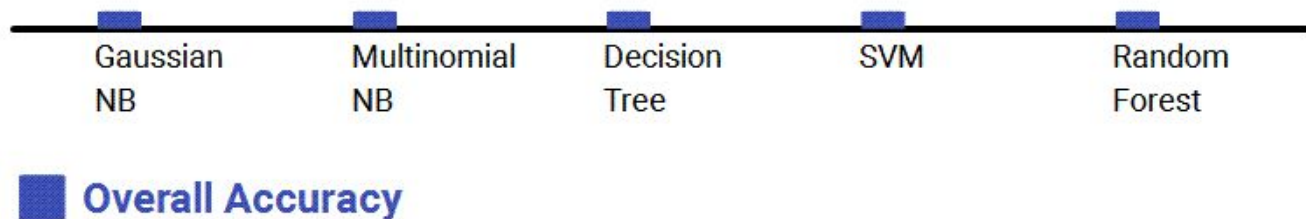
# Design/Evaluation: Algorithm

- Methods tried:
  - Naive Bayesian Classification
    - Gaussian
    - Multinomial
  - Support Vector Machine
  - Decision Tree
  - Random Forest
- Primary data used for training and evaluation
  - 60/40 split

# Design/Evaluation: Algorithm

700 Training Points

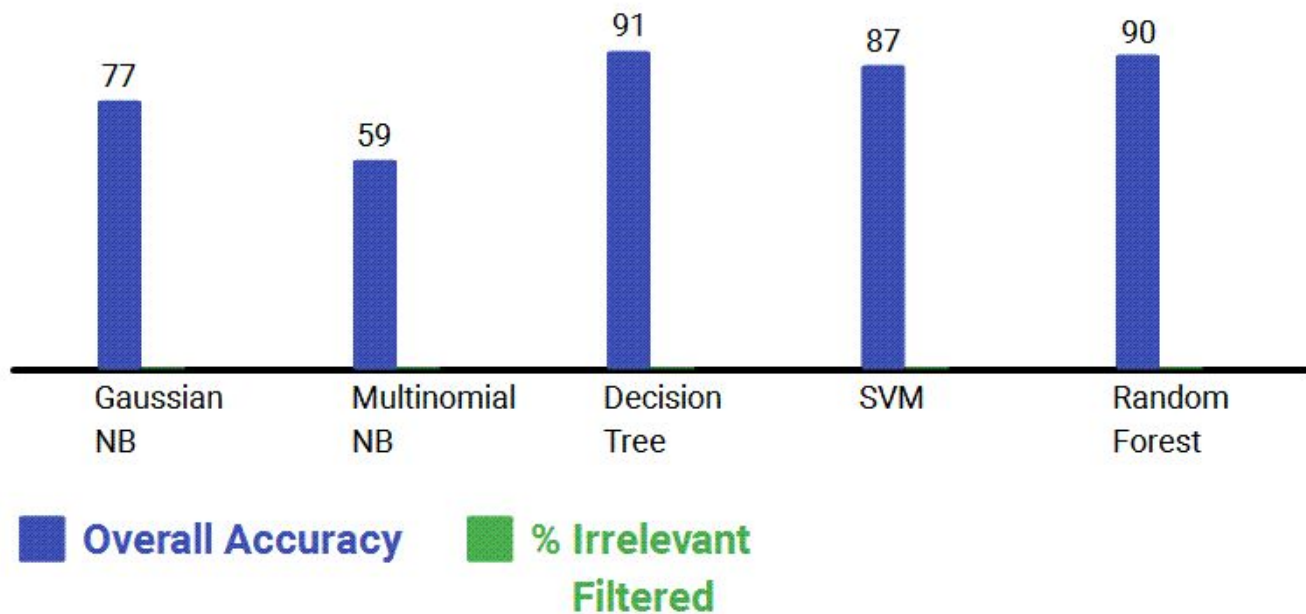
463 Test Points



# Design/Evaluation: Algorithm

700 Training Points

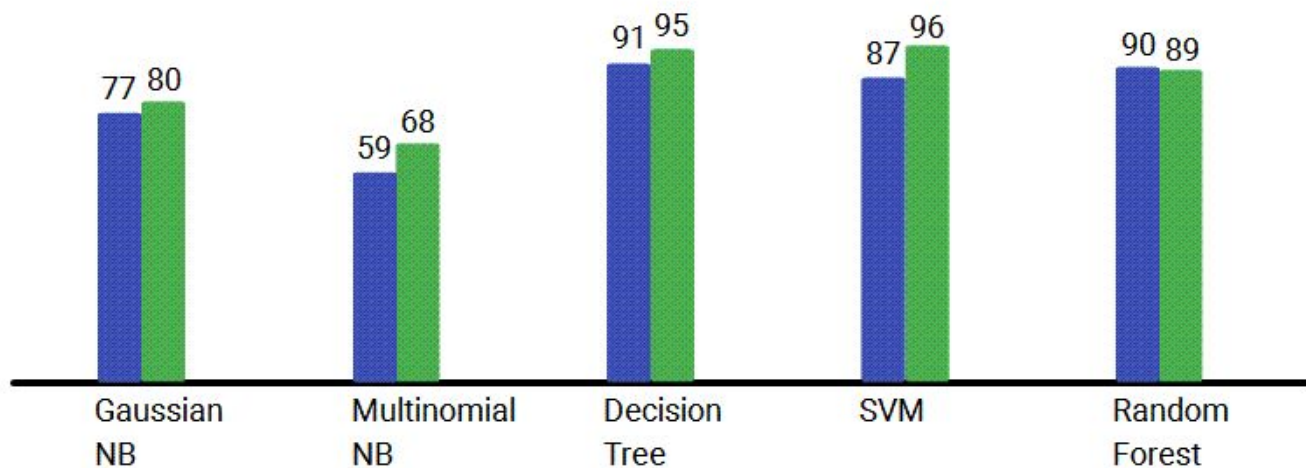
463 test points



# Design/Evaluation: Algorithm

700 Training Points

463 test points



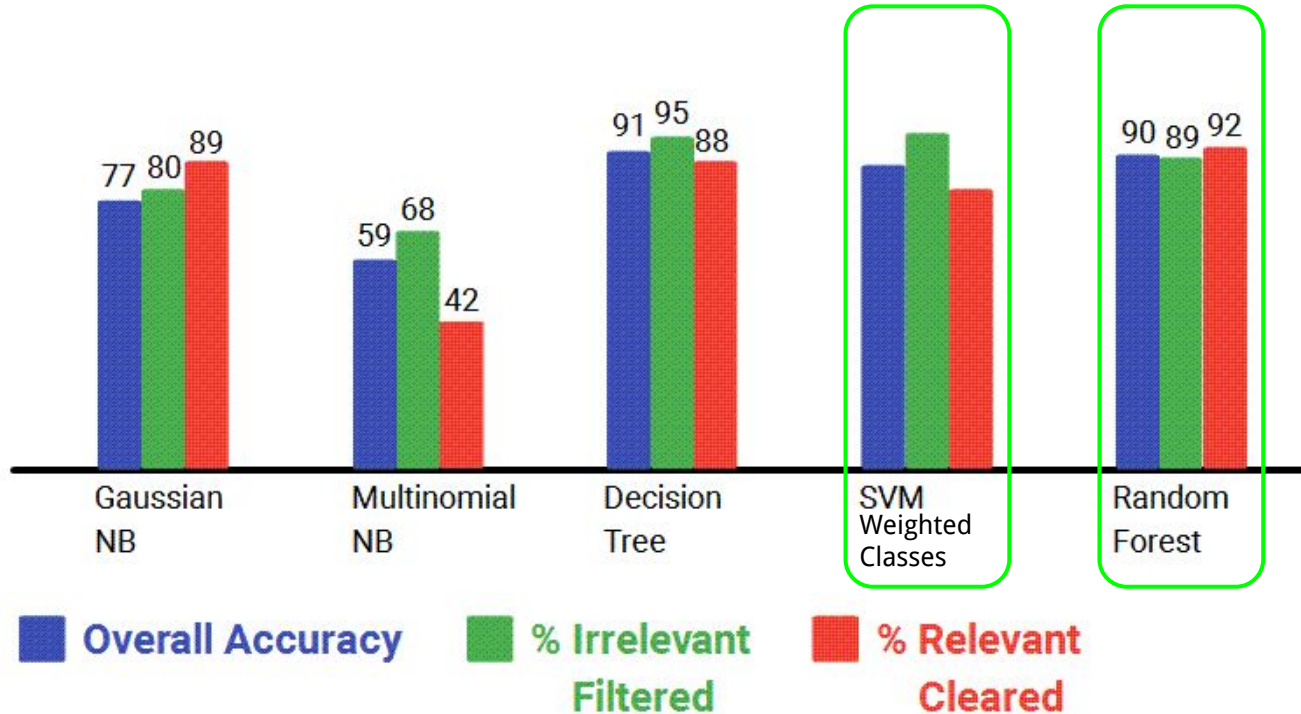
Overall Accuracy

% Irrelevant  
Filtered

% Relevant  
Cleared

# Design/Evaluation: Algorithm

700 Training Points  
463 test points



# Design/Evaluation: Algorithm

- Early stages of use:
  - Low number of data points
  - Only ML : No filtering

# Design/Evaluation: Algorithm

- Early stages of use:
  - Low number of data points
  - Only ML : No filtering

## Design Implications

Cater to each user type

Filter. Don't block.

**Prompt Feedback**

Tackle F.o.M.O

# Design/Evaluation: Algorithm

- Early stages of use
- Add-on code
  - Checks for repeated notifications
  - Classifies as last user response

## Design Implications

Cater to each user type

Filter. Don't block.

**Prompt Feedback**

Tackle F.o.M.O

# Design/Evaluation: Algorithm

- Early stages of use
- Add-on code
  - Checks for repeated notifications
  - Classifies as last user response
- ML + Add-on code:
  - Filtering starts right away
  - De-activate Add-on after sufficient data points recorded

## Design Implications

Cater to each user type

Filter. Don't block.

**Prompt Feedback**

Tackle F.o.M.O

# Evaluation: Performance

- Performance based on 18 days of training data:
- **SVM (Weighted Classes)**
  - % of irrelevant messages filtered
    - **61.22** % (180/294)
  - % of Relevant messages filtered(incorrectly)
    - **2.8** % (4/169)

		Actual	
		Relevant	Irrelevant
Predicted	Relevant	165	114
	Irrelevant	4	180

**Confusion Matrix (SVM)**

# Evaluation: Performance

- Performance based on 18 days of training data:
- **Random Forest**
  - % of irrelevant messages filtered
    - **89.11** % (262/294) **(+27.89%)**
  - % of Relevant messages filtered(incorrectly)
    - **7.7** % (13/169) **(+4.9%)**

		Actual	
		Relevant	Irrelevant
Predicted	Relevant	156	32
	Irrelevant	13	262

**Confusion Matrix  
Random Forest**

# Evaluation: Performance

- Over a period of 12 days, 180 unwanted notifications filtered
- **15** less interruptions per day

# Evaluation: Performance

- Over a period of 12 days, 180 unwanted notifications filtered
- 15 less interruptions per day
- Room for improvement
  - Would get better with time

 P3 Defence • Now

---

# Conclusion

 P3 Defence • In 2 mins

Thank You

CLEAR ALL

# Conclusion

- Against the aim of the project (reduce low priority interruptions), smart notification system (SNS) achieved **61(89)%** reduction with **18** days' data. With a false positive rate of **2.8(7.7)%**
- New interactions designed for user-system communication
- UI demo prototype developed
- A functional system prototype designed, developed

# Future Scope

- SNS as part of Android OS/ iOS
  - Better evaluation with new interactions applied
- More variables tracked for better filtering performance
- Tweaking ML algorithm for better performance

# Thank You

# Existing Methods For Managing interruptions

- Switch off the phone or put it away

# Existing Methods For Managing interruptions

- Switch off the phone or put it away
- Block specific apps:
  - Via OS settings
  - Via 3rd party apps

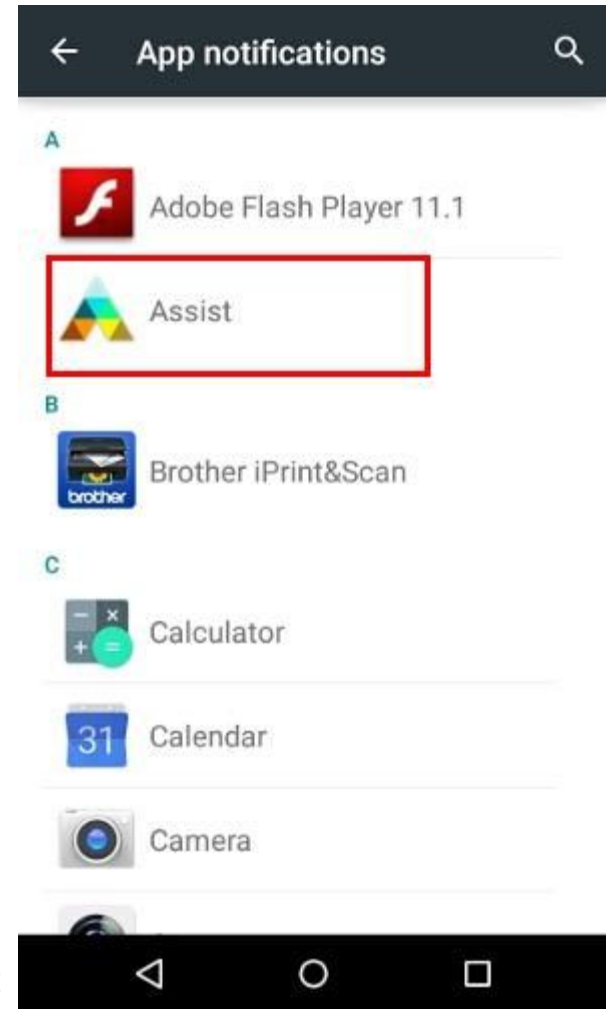


Image Source:  
<http://gadgetguideonline.com/android/lollipop/how-to-use-android-lollipops-notification-and-interruption/>

# Existing Methods For Managing interruptions

- Switch off the phone or put it away
- Block specific apps:
  - Via OS settings
  - Via 3rd party apps

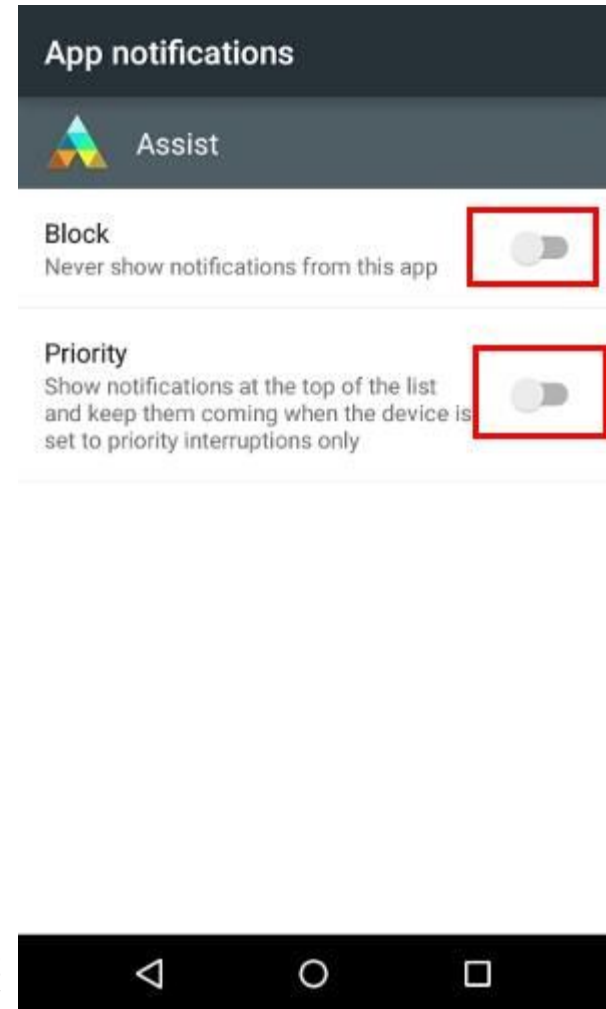


Image Source:  
<http://gadgetguideonline.com/android/lollipop/how-to-use-android-lollipops-notification-and-interruption/>

# Existing Methods For Managing interruptions

- Switch off the phone or put it away
- Block specific apps
- Priority/DnD modes
  - OS supported (Android Lollipop and above)
- 3rd Party apps

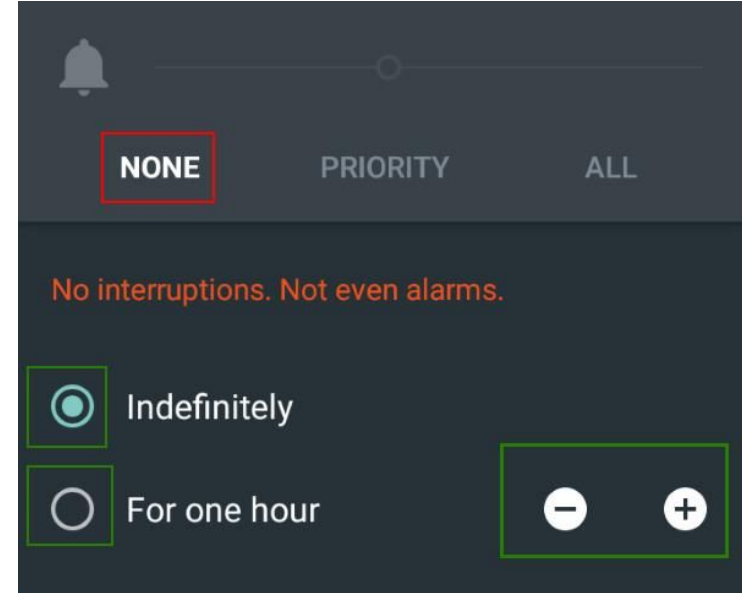


Image Source:  
<http://gadgetguideonline.com/android/lollipop/how-to-use-android-lollipops-notification-and-interruption/>

# Existing Methods For Managing interruptions

- Drawbacks:
  - User may miss out on important/urgent interruptions

# Existing Methods For Managing interruptions

- Drawbacks:
  - User may miss out on important/urgent interruptions
  - User is required to know of the existence of such methods

# Existing Methods For Managing interruptions

- Drawbacks:
  - User may miss out on important/urgent interruptions
  - User is required to know of the existence of such methods
  - There is no fine control (except for phone calls/messages - which requires manual setting up)

# Existing Methods For Managing interruptions

- **User may not be aware of the effect interruptions have on their productivity**

