

An aerial photograph of Powai Lake in Mumbai, India. The lake is a deep blue, occupying the lower half of the frame. In the background, a dense cluster of high-rise apartment buildings and commercial structures stretches across the horizon. The buildings are mostly light-colored with many windows. Some buildings have distinctive architectural features like domes or tiered tops. The sky is a clear, pale blue. In the foreground, there's a small, green, tree-covered peninsula jutting into the lake. A small boat is visible on the water in the lower right corner.

**street furniture for 'powai'
special focus on lake front road**

Role of street furniture in public open spaces

Public open spaces are:

- Curial components of a city in terms of physical and social Functions
- Image of a city
- People interact under collective identity
- Public open space without street furniture (OOH) is meaningless.

Objective

- Create interesting public open space for 'Powai'
- Provide essential services of street furniture and conveniences for users who come to 'Powai' lake face road for recreation & leisure
- Special consideration to design and enhance the public open space such as 'Powai' lake front
- Define the item of street furniture required for the place and their location
- Provide Nomenclature of “OOH” furniture for 'Powai'

Scope of the project

- This street furniture is designed for 'Powai' (lake front) from IIT B main gate to L&T
- Coordinate set of “out of home” furniture based on the users need
- Provide iconic street furniture where it is needed based on the assumption of design, build, maintain and advertize
- Advertising on street furniture is a high marketing share and gives an attractive look to a city
- Enhance people habit to keep the place clean.

What street furniture includes?

About 'Powai'

- According IRCC, IIT Bombay the name 'Powai' has been the **home to five temples**
- It is believed that the word 'Powai' came from the temple, Its etymology is drawn from '**Padma Aai**', which means **mother Padma**, in 'Marathi'.
- 'Powai' comprised **five villages:**
 - Saki
 - Kopri
 - Tirandaz
 - 'Powai'
 - Paspauli



- 'Powai' is host to some important landmarks of Mumbai, such as:
 - # Indian Institute of Technology, Bombay
 - # Hiranandani Gardens Township
 - # Construction, engineering and manufacturing conglomerate Larsen & Toubro group of companies...
- Thousands of devotees every year during the Ganesh Chaturthi festival for the visarjan processions.
- A 123-year-old lake that was originally used to supply water to the city of Mumbai, But today used as an industrial sewage outlet

Case study in 'Powai' Street

This study covers from IIT B YP gate to L&T flyover which is about 2.2 kms. It has one Side Lake and buildings on the other.



Image from Google earth

1. Benches

- People used to sit on the concert barrier structures used to prevent access for cattle and people in to the lake.
- Concrete seat becomes hot during day time that users cannot sit on it.



2. Litter bin

- Difficult to collect the wastes from the litter bins
- The wastes are burnt inside the bins and users choose to throw the garbage in to the lake around them.



3. Public convenience:

- No public convenience in this area.
- People used urinate either around the streets
OR
to some corners of the street or in to the lake side.



4. Bus stops

- There are 7 bus stops from IITB main gate till L&T.
- Three of them have shield and four did not.
- Information board of the bus stop is not understood to new bus users and very crowded fonts



5. Direction Boards

- Massive stainless steel columns for small direction board



6. Bollard:

The bollards have no reflective light to show signals for the vehicles as well as pedestrians



7. Vending kiosk

- No vending kiosks in the area
- Users get snakes from hawkers
- This increase the amount of wastes dumping in the lake



8. Play ground for children



Playground is better place functionally well but there is no liter bin around



9. Elements on the site

- People used as a land mark in 'Powai' street (apartment buildings, hotels, lake face)
- Elements are repeated Vertically and horizontally

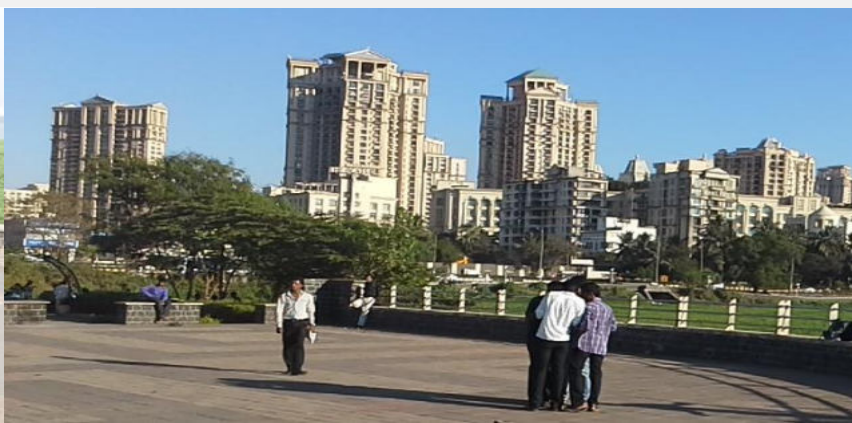

Behavior of the people



- ✓ Sleeping
- ✓ Sitting in pair
- ✓ Sitting face to face
- ✓ Putting out chappals, shoes while seating
- ✓ **Sitting with cross legs.**



Why people come to lake front?

- Lake front is a nice public amenities
- Walking around lakeshore creates free mind
- To get fresh air from the lake
- To see nature (Birds, fish, reflection of the tree and building...)
- Ducks float in the lake, search their foods (fish and other amphibians) from it

Need for street furniture

- User came to 'Powai' lake with their relatives to recreate themselves after office hours in uncomfortable situation
- The place is highly affected by dumping huge garbage
- Maintain the lake side as a recreational area In such away that people would keep it clean
- It is a peace full place related to the entire city

General observation in 'Powai' lake face road

- Reflection of buildings & trees on the lake which gives a good view
- 'Powai', as a recreation area doesn't have shade and plantation to protect the user from harsh sun
- Uncontrolled waste management (plastic bags of chocolate, biscuits; ice-cream cups, plastic tea cups and chewing gum packaging are the common wastes in this place)
- Things offered for god '**Nirmalya**' immerse in to the lake /which can't stop

Cont'd

- Few and substandard bus queue shelter, especially during the day time, user exposed to a harsh sun while they are waiting for the buses
- Site is not comfortable for elderly and disable people
- Buses came in every 10min. but sometimes they delayed about 30 to 40 minutes because of the traffic jam
- No enough litter bins and less awareness on the user
- No proper seat to stay around the lake

Cont'd

- No shade during day time users are exposed to harsh sun
- No public convenience that people used to urinate around the street and the lake
- No vending kiosk, get snacks from hawker. this increase the uncontrolled dumping of waste in to the lake
- Existing Products are not maintained regularly

Case study in Hiranandani

- **A Neo classical architectural marvel** nestled amidst the verdant 'Powai' hill, where more than 4000 families stay.
- 'Powai' Lake is a good view for those flats and those people who stay in Hiranandani flats come to this lake for recreation and leisure.

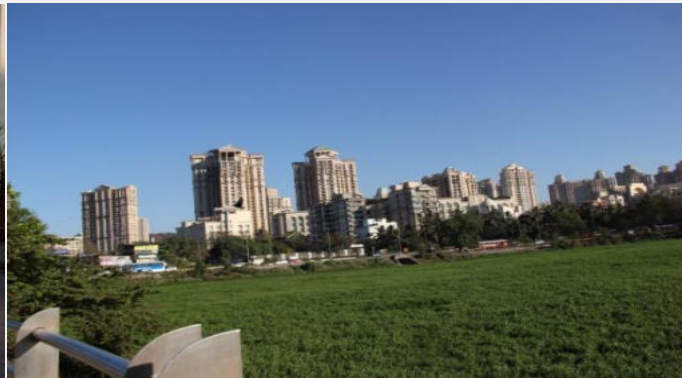
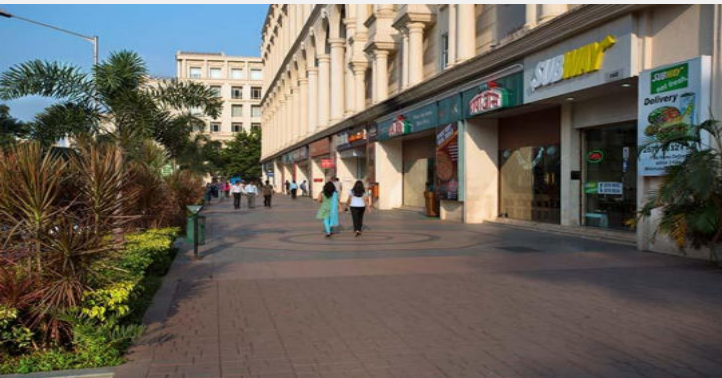

Case studies in similar places, Mumbai

1. Marine drive



Observations

- People used to sit in this area on the 3.3 km concrete (stone) seat built to the seaside which is hot during day time
- The public convenience located in the mid way of the street is only one and that was closed because of improper usage by the public.
- Other services below the bridge where users can get the service by paying 3 Rps per Person.



Public convenience



3.3 Kms Concrete Seat and used as a barrier

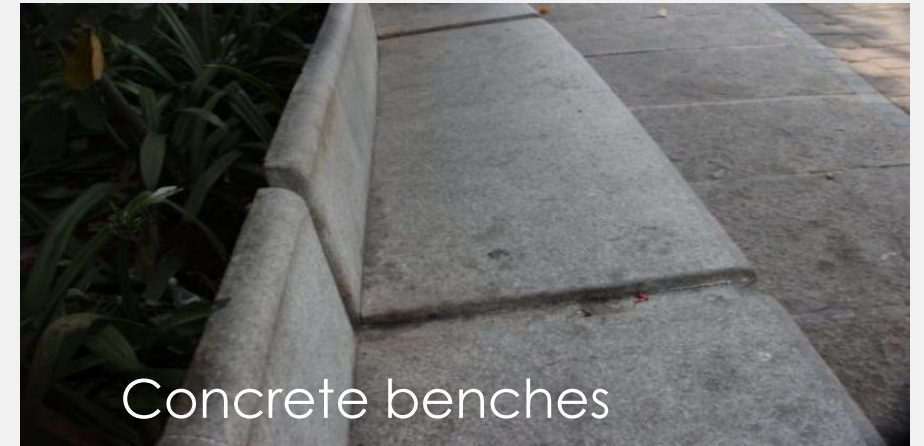

Concrete benches



Public toilet under the bridge



Benches - With shade

Vending kiosk

- People get serves like drinking water, and some fast foods from this kiosk in Marine drive



2. Worli Sea face

This area is other similar place to Marine drive and 'Powai' Lake, with different types of street furniture.





Concrete bench



Public convenience



Bus Stop



Sport equipments

Proposed street furniture

According to the problems in 'Powai' lake the following furniture are proposed to develop and finally detailed one of them(Bus stop with vending kiosk)

- Benches
- Bus stops
- Litter bin
- Public convenience
- Vending kiosk
- Bollards
- Information boards
- Lights

4. Street furniture service providers

TIMES OOH™

 PIONEER
OUTDOOR ADVERTISING



MMRDA
MUMBAI METROPOLITAN REGION
DEVELOPMENT AUTHORITY

JCDecaux

LAQSHYA
MEDIA GROUP

Studying similar furniture in the world



**Benches
Mood board**



Bus Queue shelter

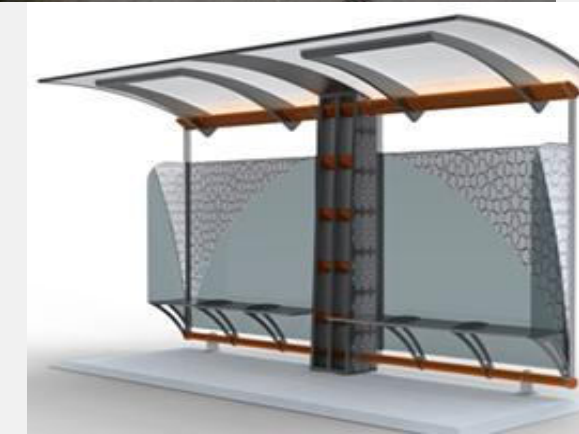
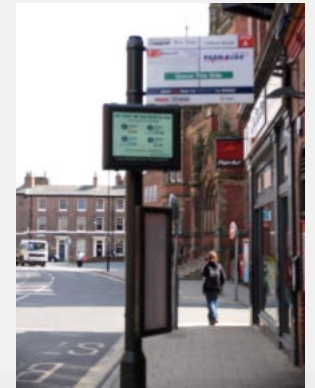

Litter bins



Public convenience



Vending Kiosk



Bollards

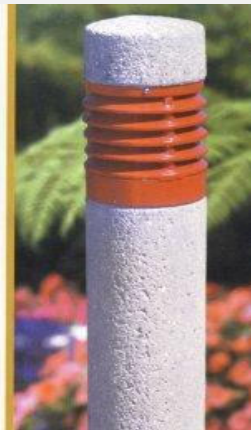

Design brief

Design a set of **Street furniture for 'Powai' special focus on Lake Front road with the following considerations,**

- Sturdy, easy for maintenance,
- Free of traffic accidents,
- Environmental friendly, theft and vandal proof,
- Simplistic, Modern and Iconic(family look)
- Ergonomically designed for Indian population
- Self financed for maintenance through limited right for advertizing at zero cost to the city on build and operate basis sponsored by some companies.
- The furniture has briefed in item wise.

Benches

- Ergonomically designed for easy use and accessible by different people,
- Comfortable and environmental friendly
- Aesthetic and stable, simple, elegant and practical
- Vandal and theft proof, strong and corrosion resistant easy to maintain

Bus stops

- Environmental friendly
- Practical ,vandal proof and ease of maintenance
- Modular, Lighter, strong and corrosion resistant
- Ergonomically designed for easy use and accessible by different people
- Unique, modern and memorable
- Friendly and approachable

Litter bin

- Easy to clean and empty the wastes maintain
- Clean looking, elegant, modern, simple, practical and accent in the urban environment
- Lighter and corrosion resistant
- Ergonomically designed for easy use and accessible by different people
- Easy to maintain and convenient/ inviting to use

Public convenience

- Clean and practical
- User and environmental friendly
- Aesthetically appealing , Contemporary, easy to use and maintain
- Ergonomically designed for easy use and accessible by different people
- Approachable and convenient / invite to use
- Safe and secure

Vending kiosk

- Environmental friendly
- Modular, simple and Contemporary
- Aesthetically appealing, unique, modern, memorable and functional
- Easy to maintain and inviting
- Strong and corrosion resistant
- Secured, safe and convenient to use

Bollards

- Unique, modern, aesthetically appealing, contemporary, simple and elegant
- Theft and vandal proof, Stronger and rust proof
- Ergonomically designed for easy use and accessible by different people
- Iconic, durable, Easy to maintain and stable

Lights

- Multipurpose(lighting, CCTv camera, as a flag pole, advertisement)
- Strong, durable and rust proof
- User and environmental friendly
- Iconic and practical

Direction boards

- Unique, modern, memorable and functional
- Easy and multi lingual information
- Aesthetically appealing , Contemporary and practical
- Vandal and theft proof, rust resistant and stronger

Design considerations

- Built, erected and maintained by sponsored companies such as L&T, Hiranandani, IIT B etc... and will be given limited advertising right to receive the cost of erection, and maintenance(ex. MMRDA procedure)
- Monolithic and fewer joints to avoid accumulation of dirt and water making
- Rounded edge, fire resistance and skid proof for pedestrian safety

Cont'd

- Modular nature products to extension in the same proportion where necessary
- Galvanized steel for durability
- None toxic materials
- Theft and vandal proof
- Aesthetically appealing, simplistic, and easy to maintain
- Lighter, stronger and rust resistant
- Safe and secure

Design constraints

- Street furniture will have contemporary material and feel
- Furniture should have a 'family' look
- Fixed/ non- movable furniture
- Furniture design related to landscape design
- Space available in the street limits design idea
- Street furniture design is better to adopt the cities and Architecture of the area in order to depict the history and is good mean adopt objects to urban.
- Street furniture will complement the over all landscape design

Design guide lines/ zoning

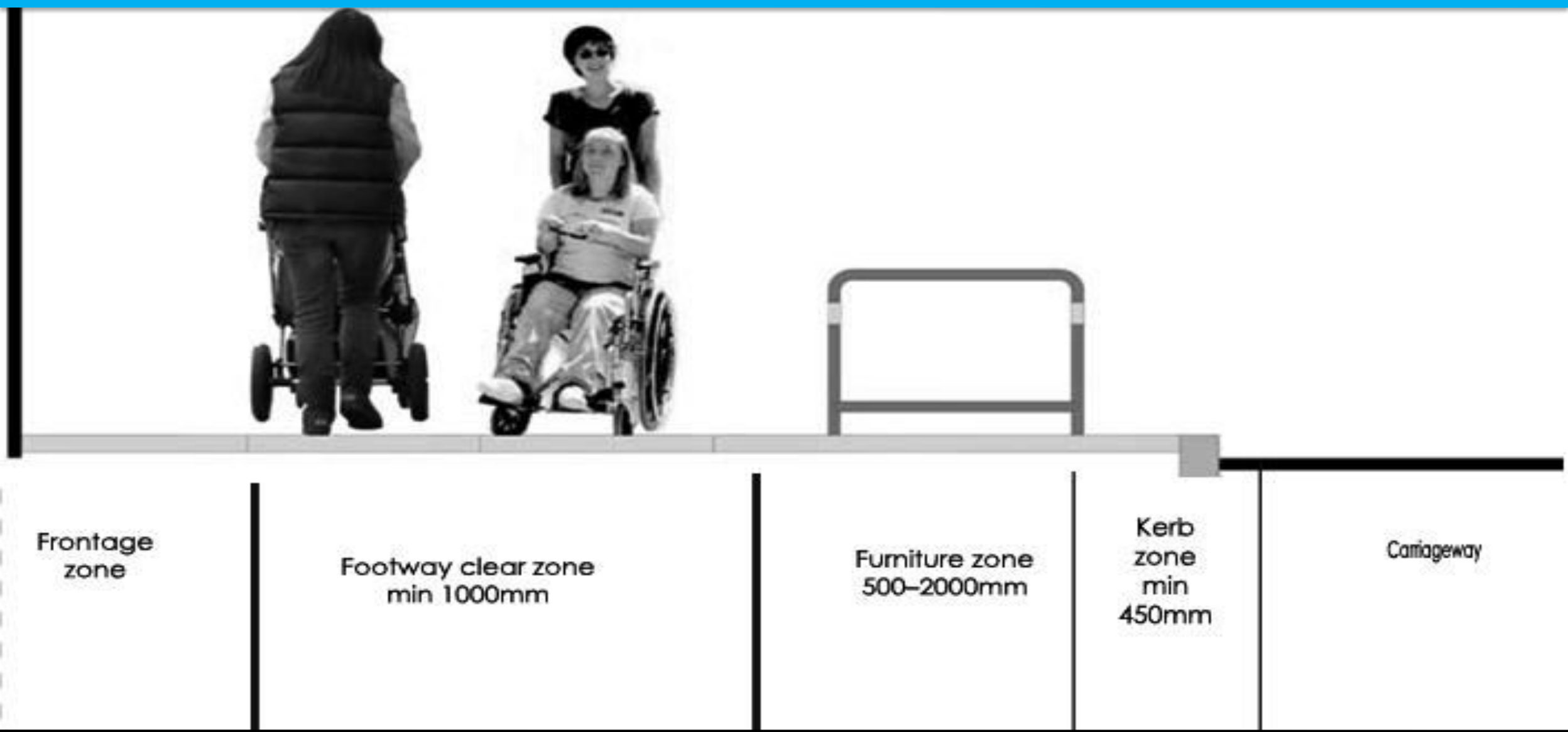

Stage 2

Ideation

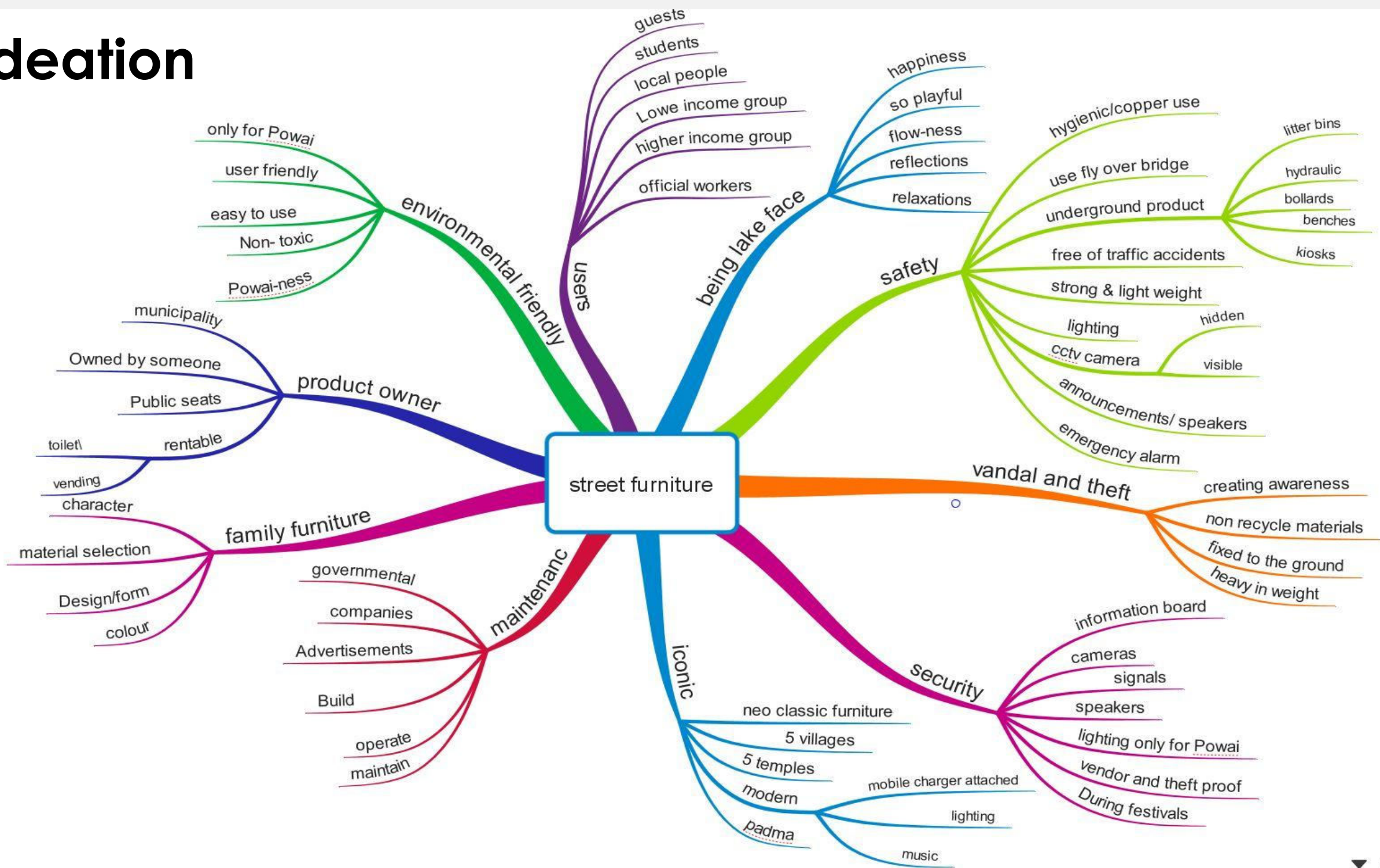

Benches

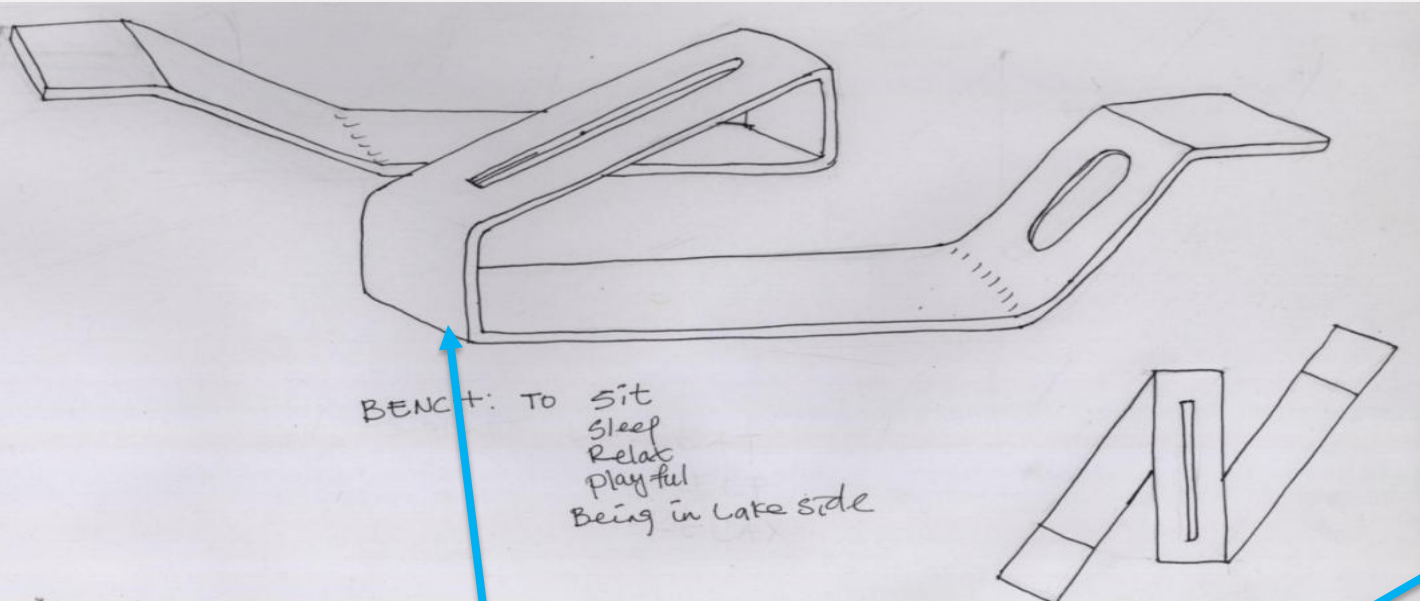

Use as a seat,
Sleep relaxed, alternate
seat (side face to face)

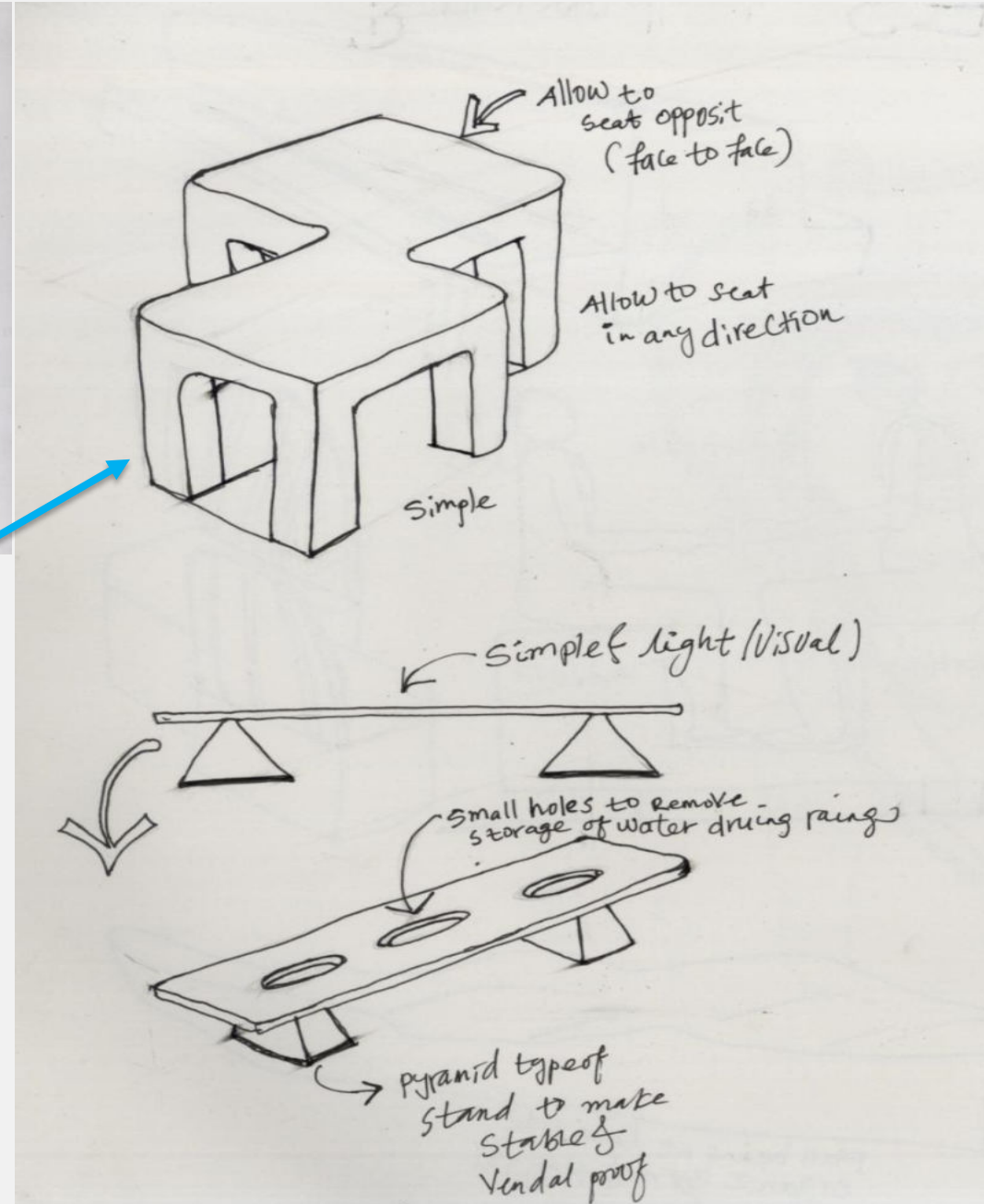

BENCHES

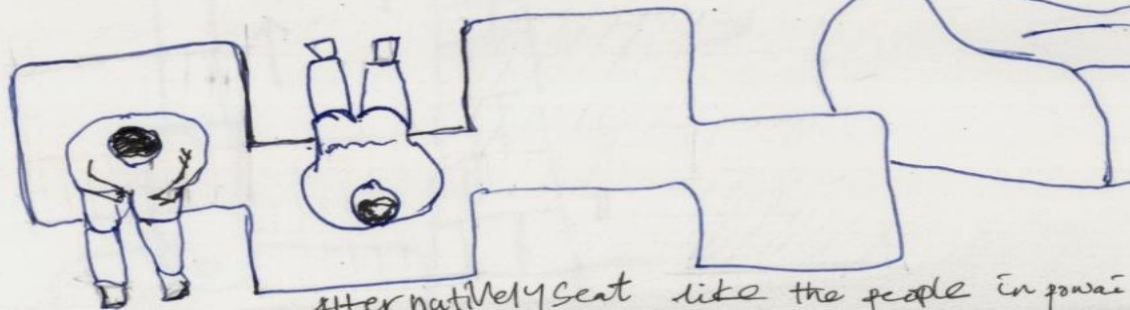
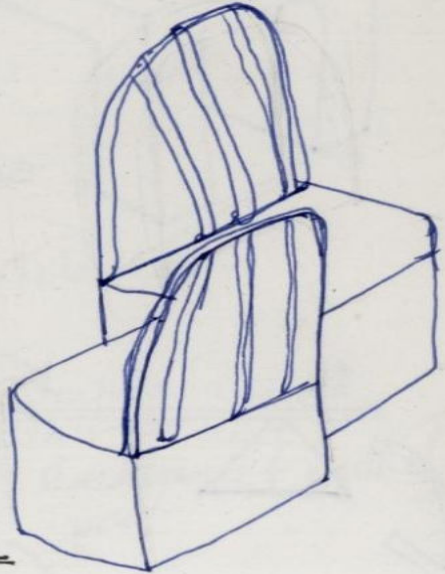
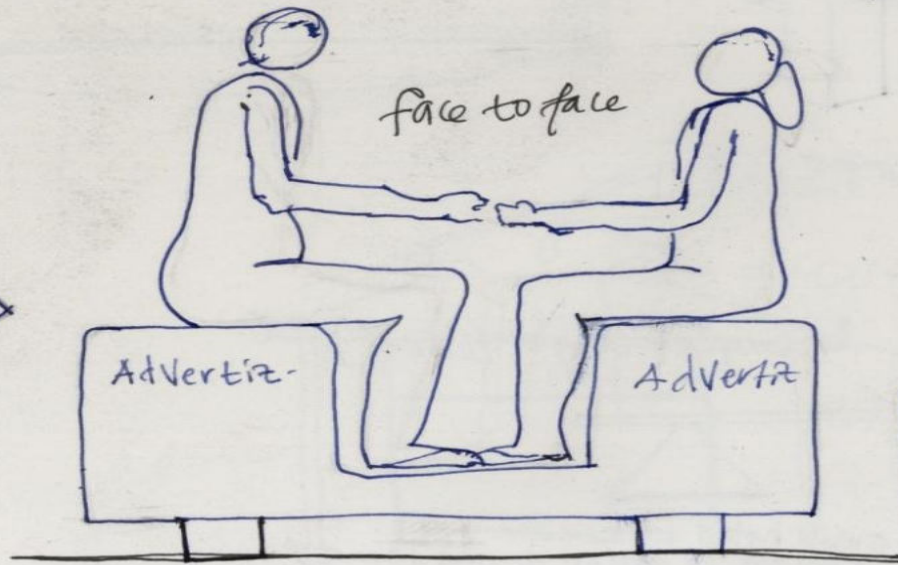
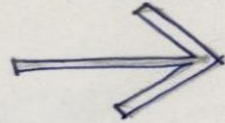
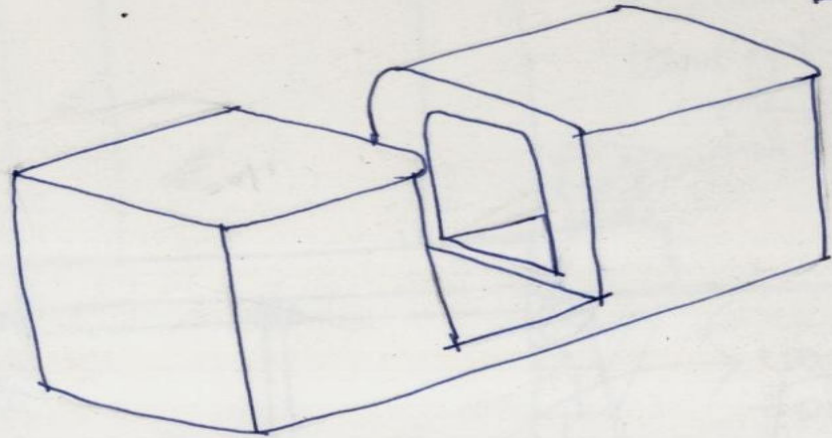
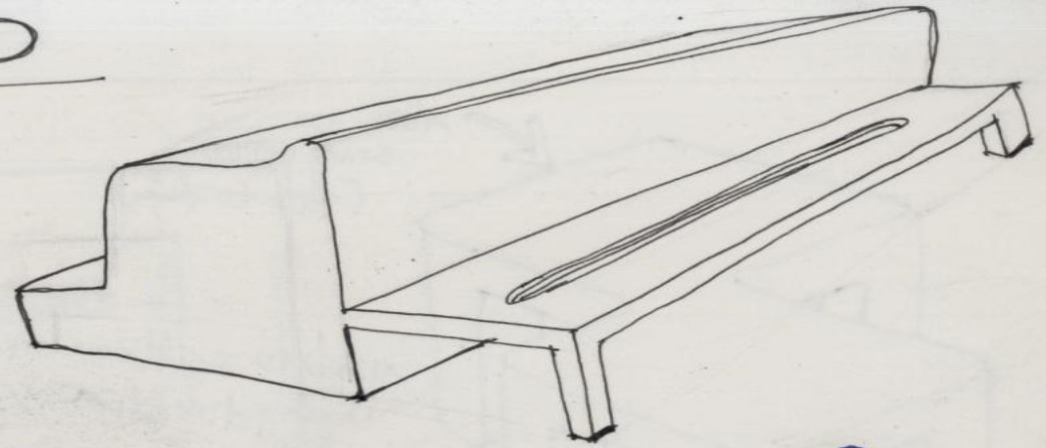
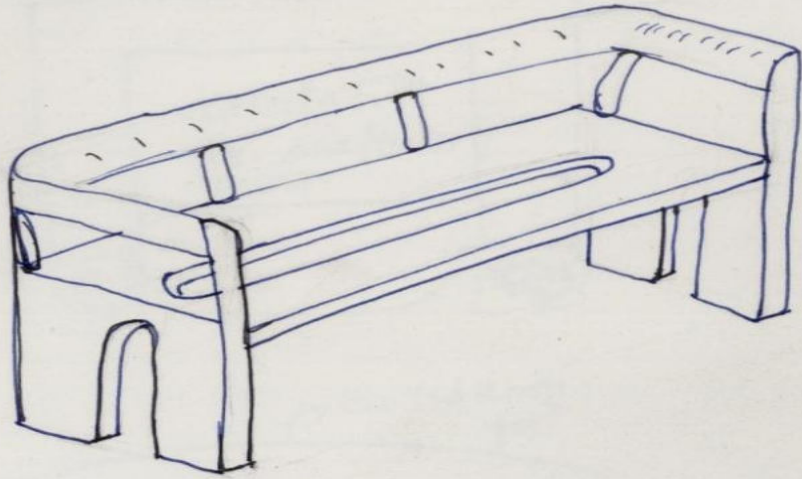

alternatively seat like the people in power

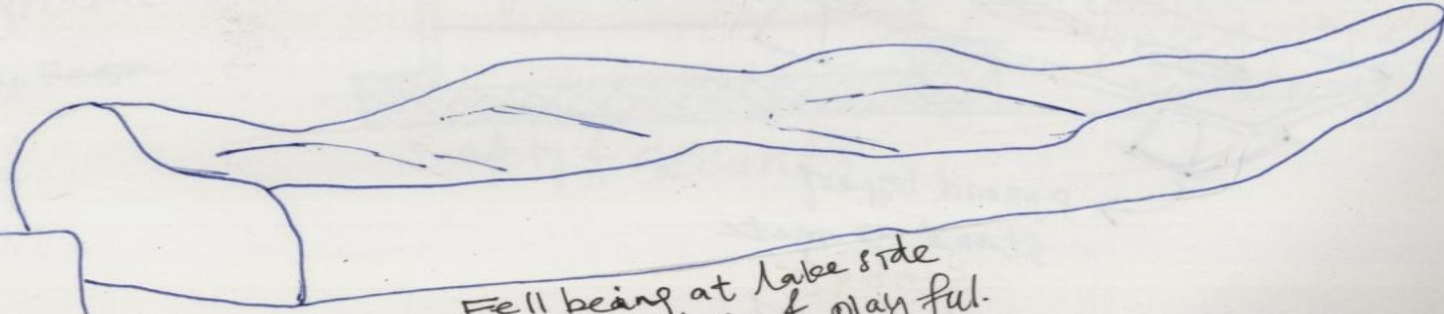

Fell being at lake side
organize form of playful.

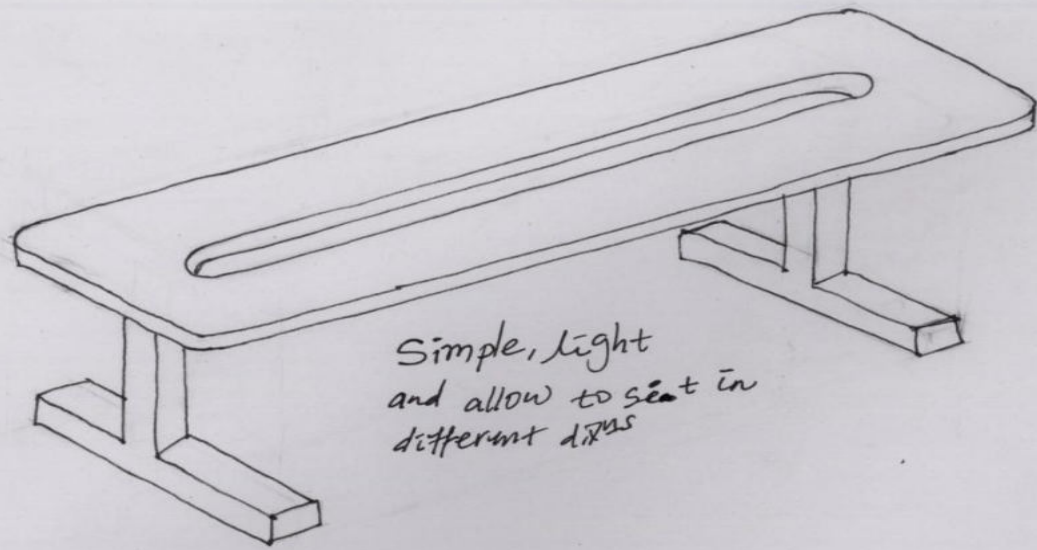

Simple, light
and allow to seat in
different dirns

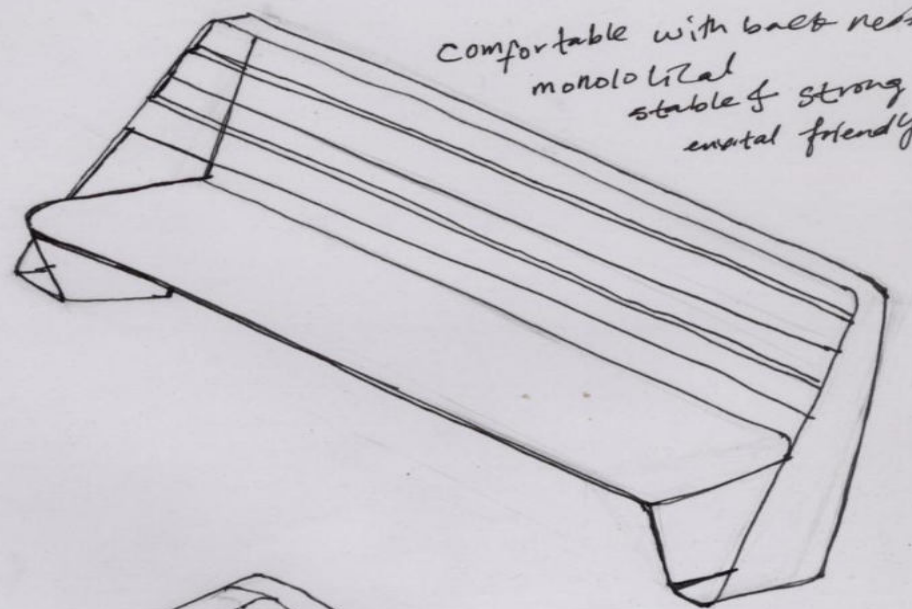

Comfortable with back rest
monolozal
stable & strong
envatal friendly

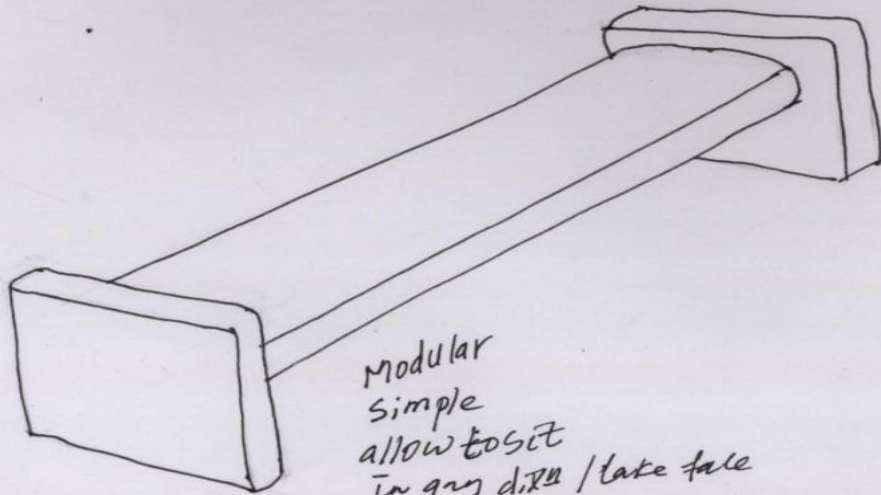

Modular
Simple
allow to sit
in any dirn / take face
street face / or face to
face

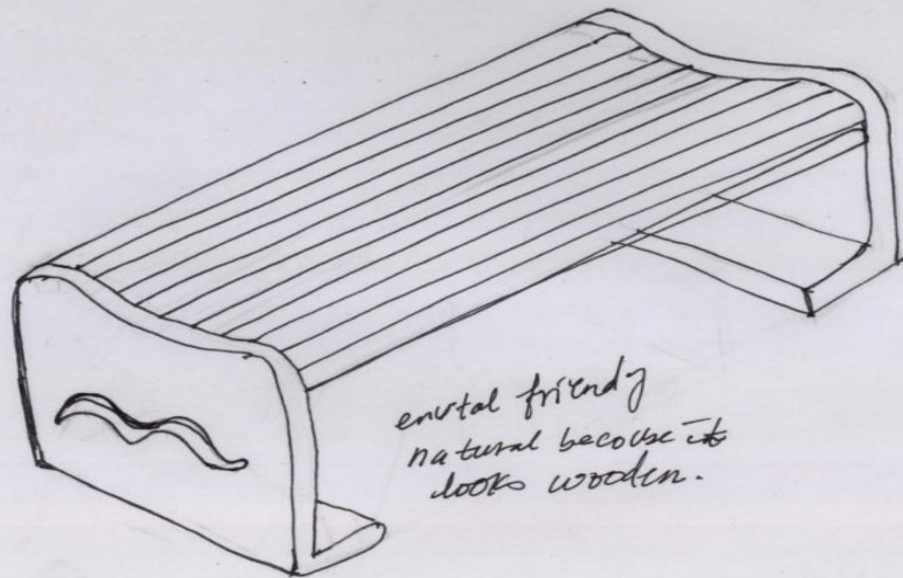

envatal friendly
natural because it
looks wooden.

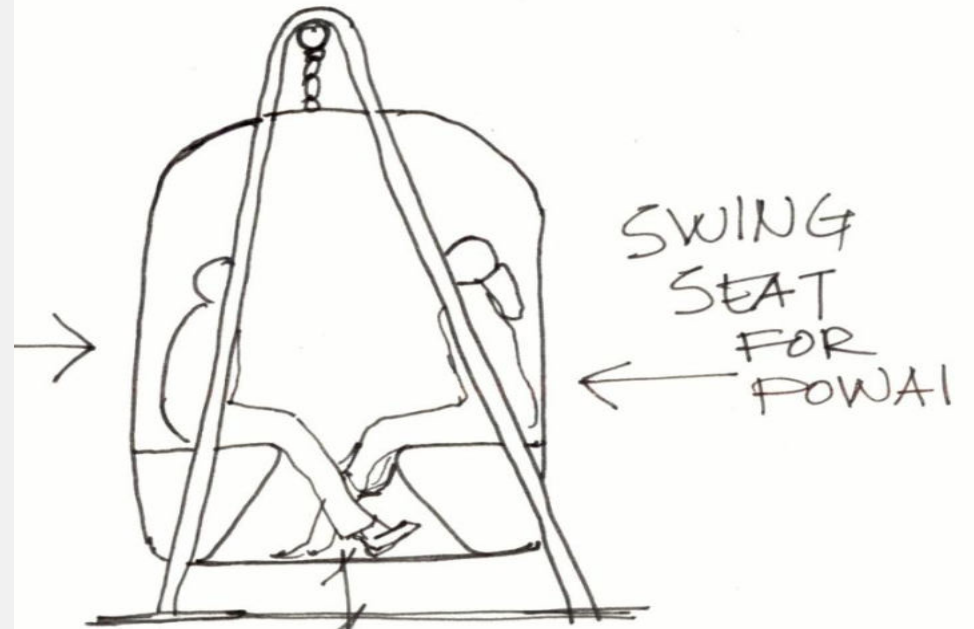
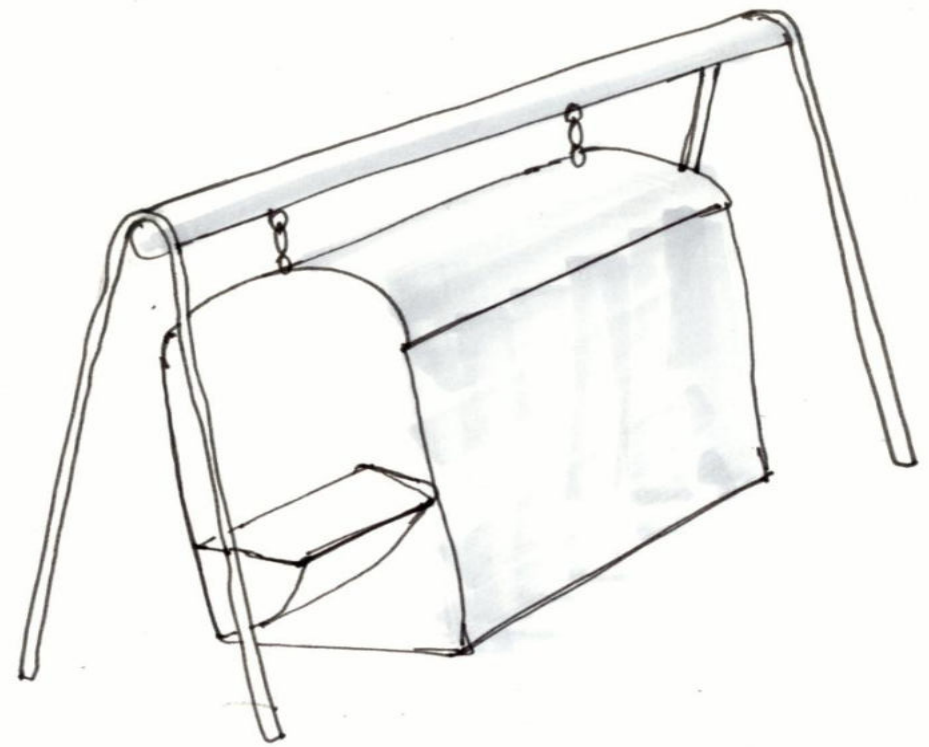
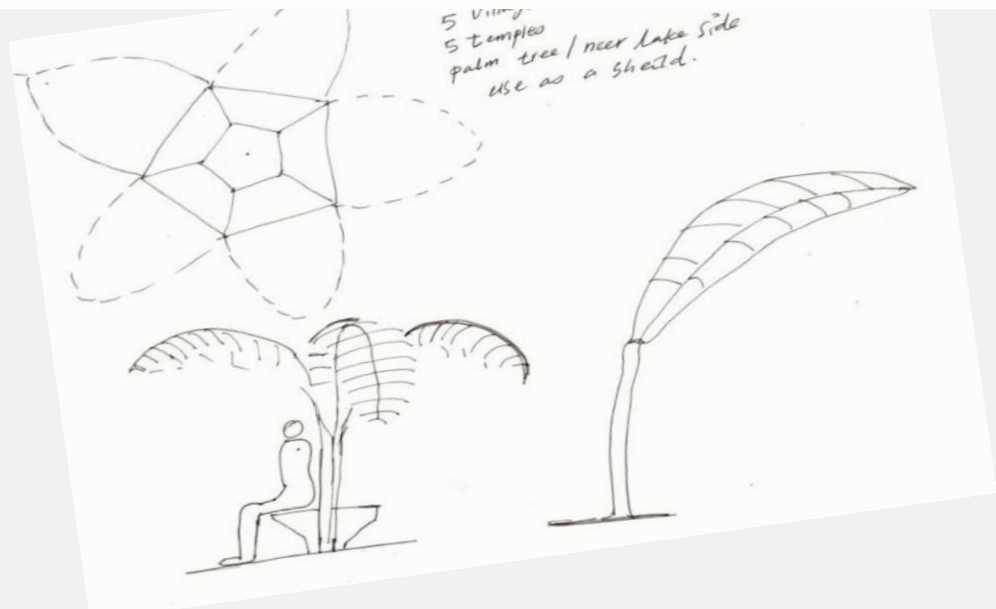
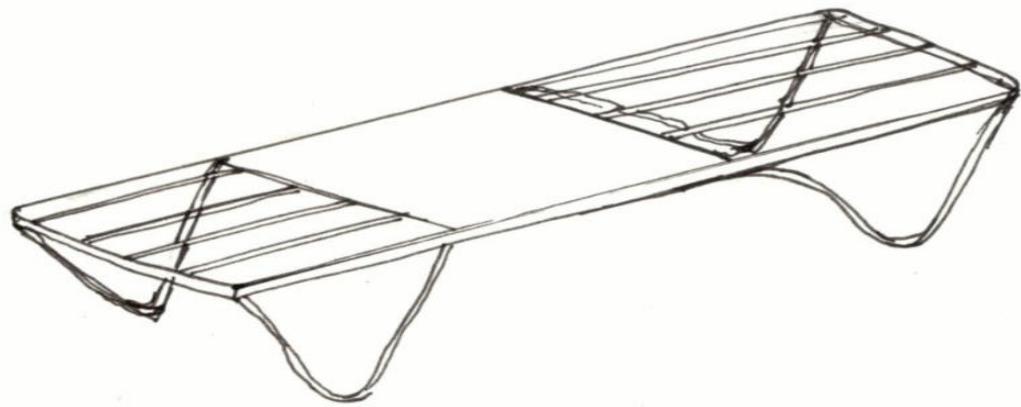
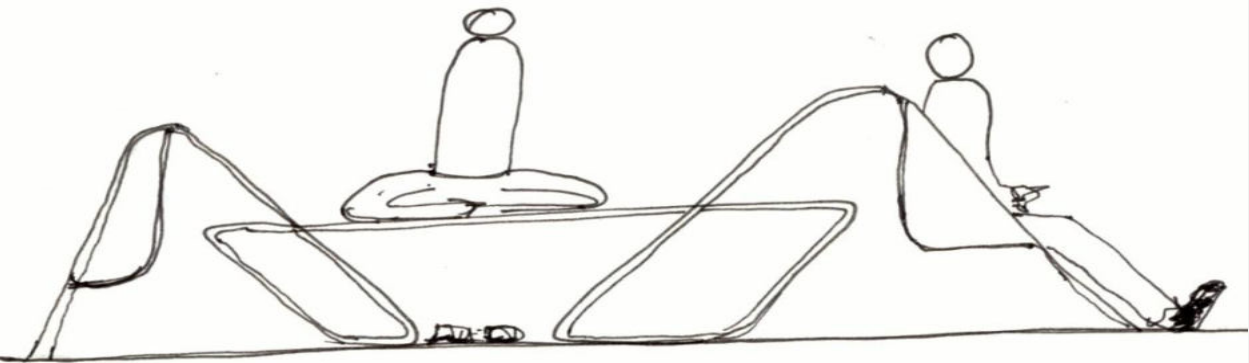

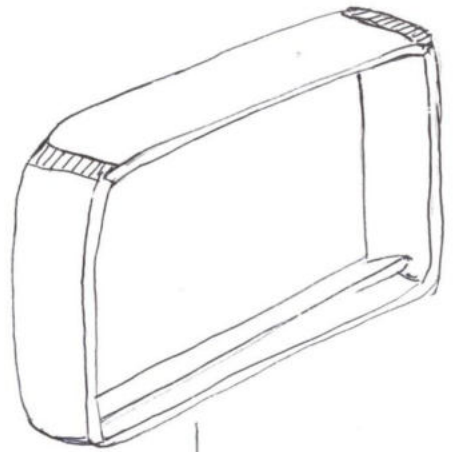
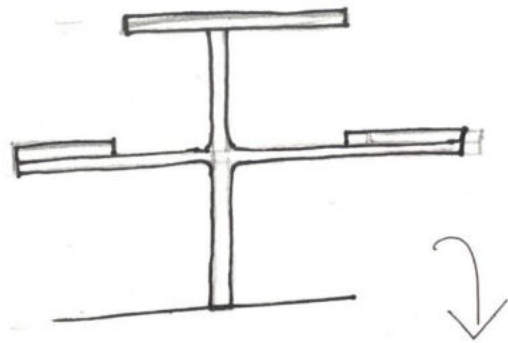
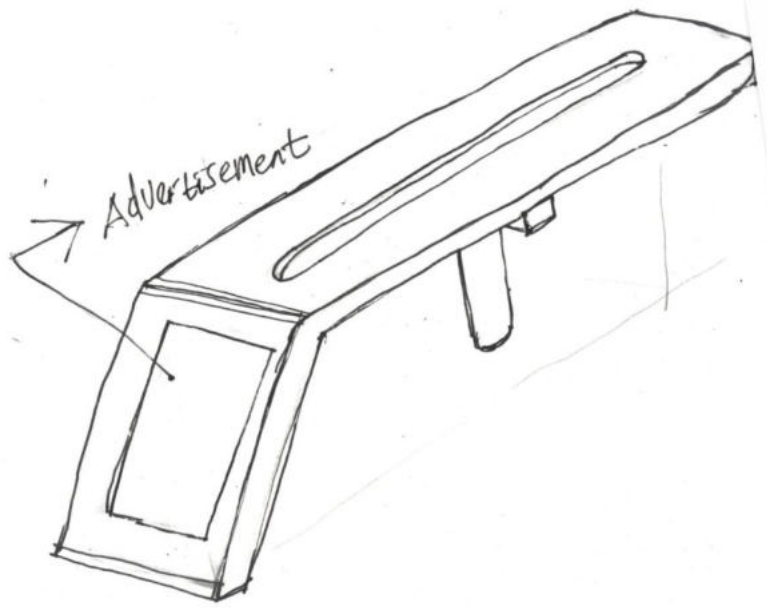

SEATS

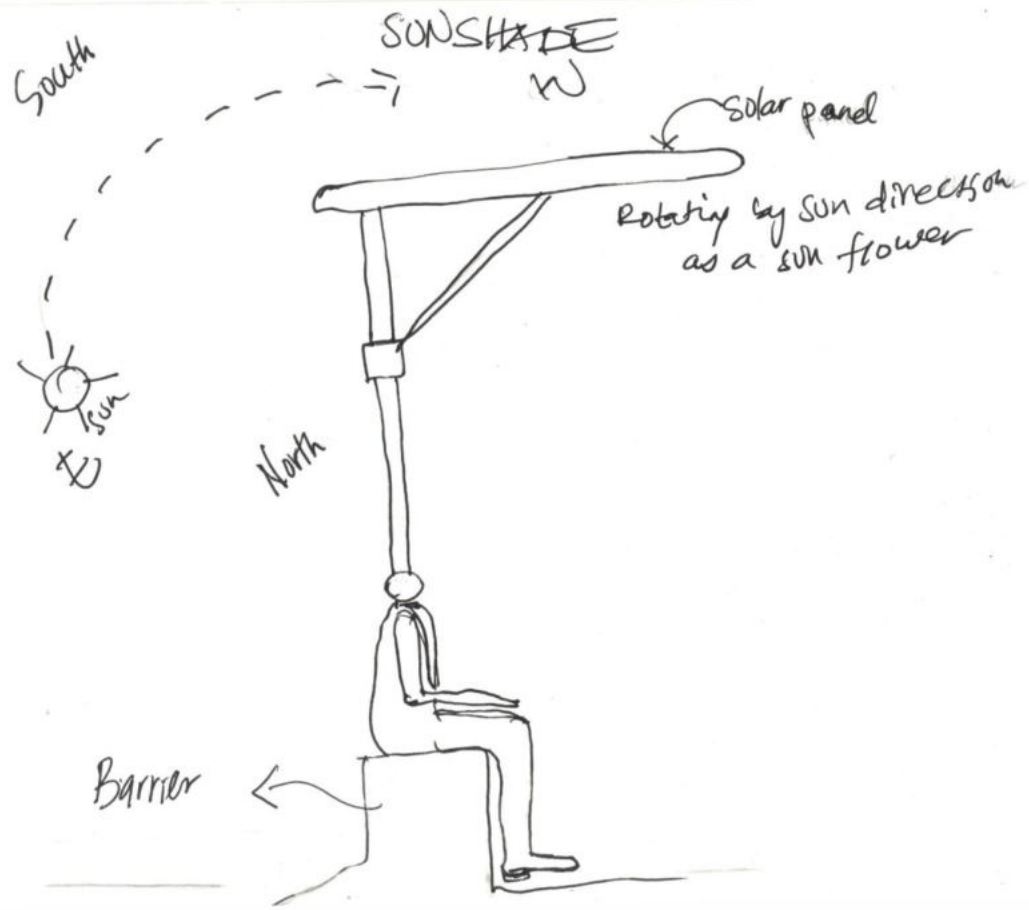
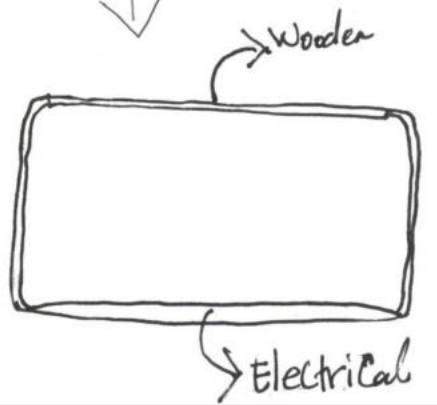
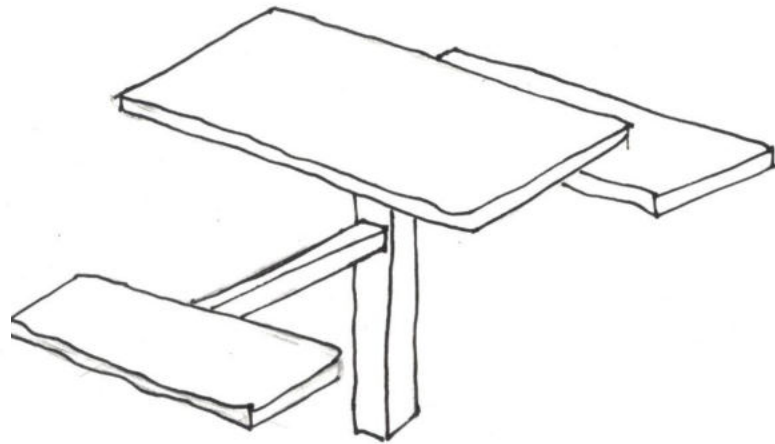

Vending kiosk

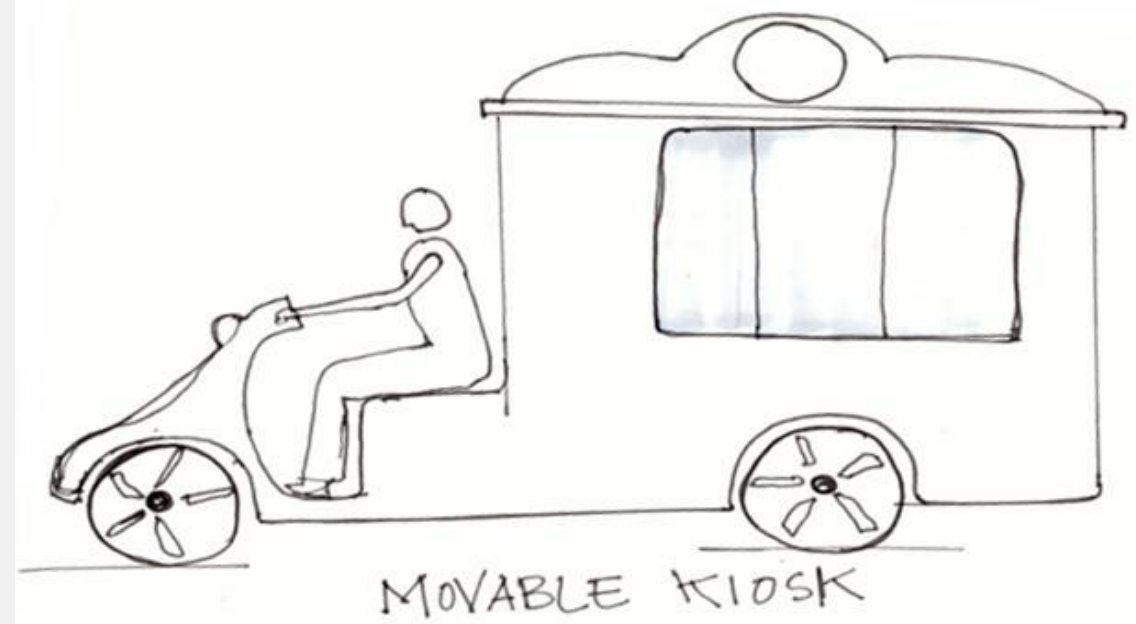
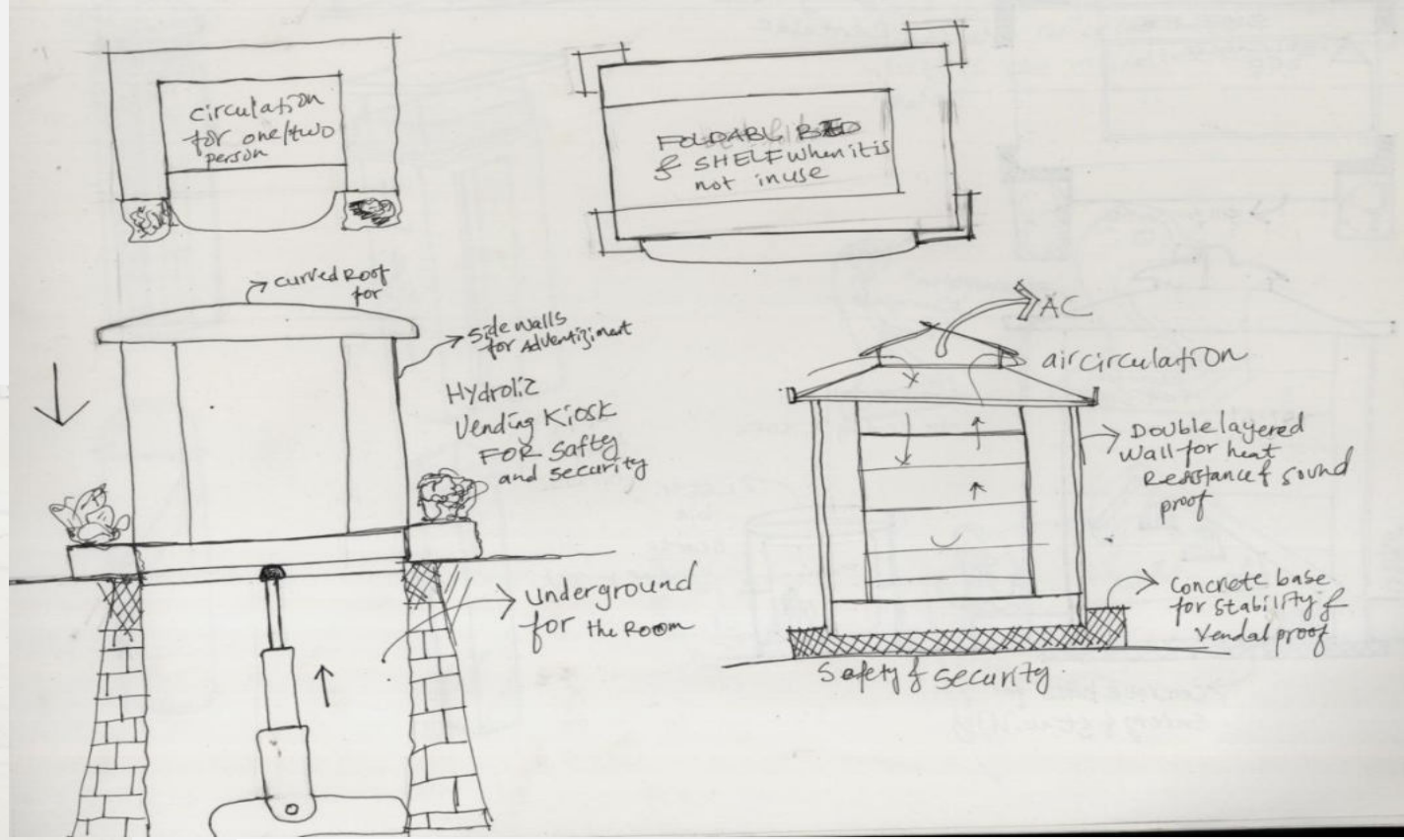
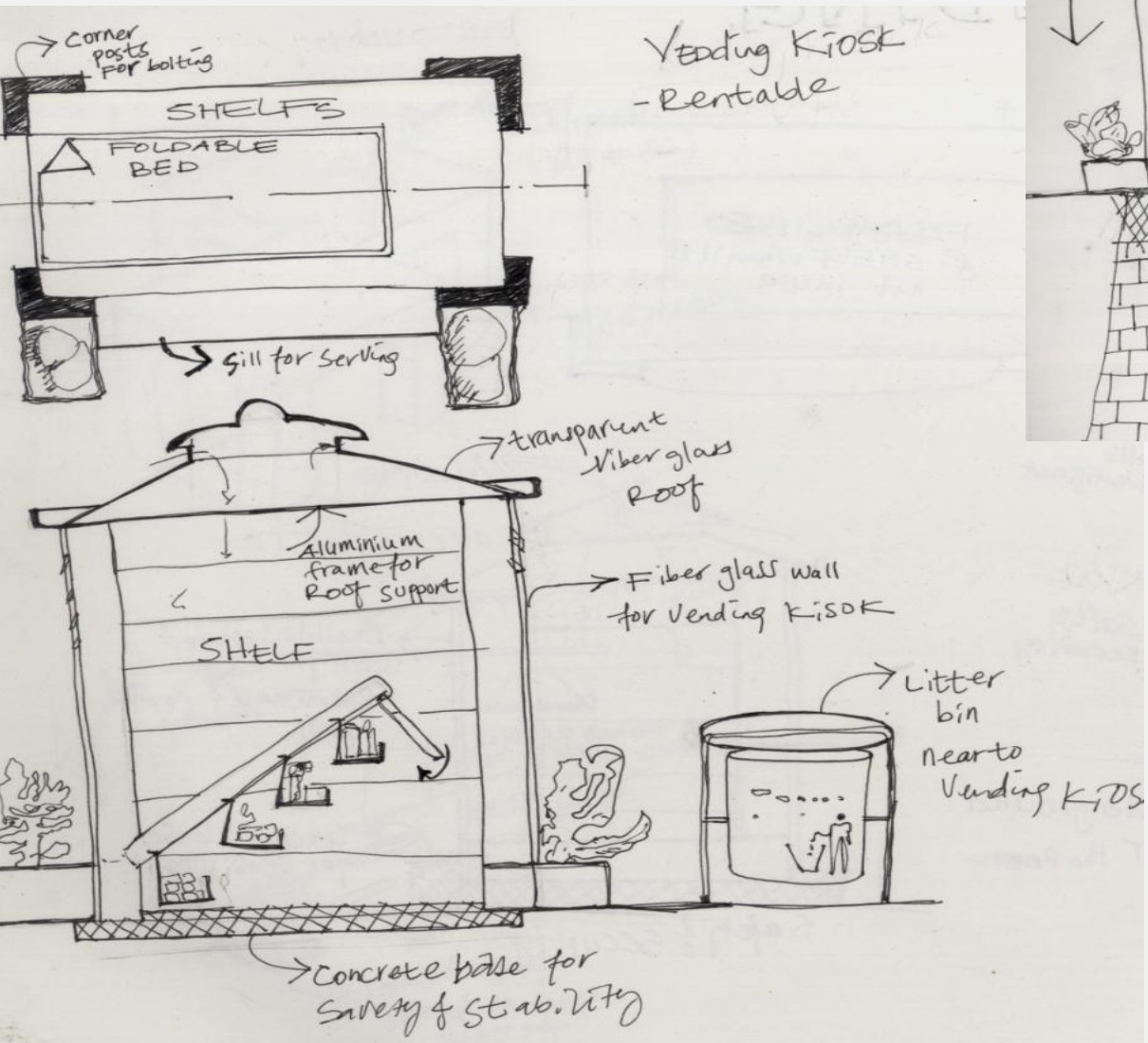

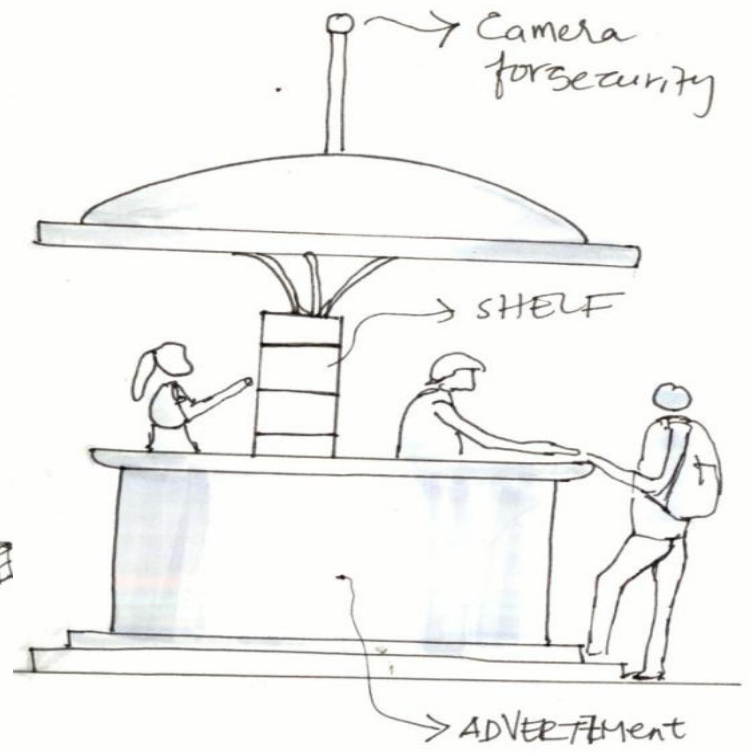
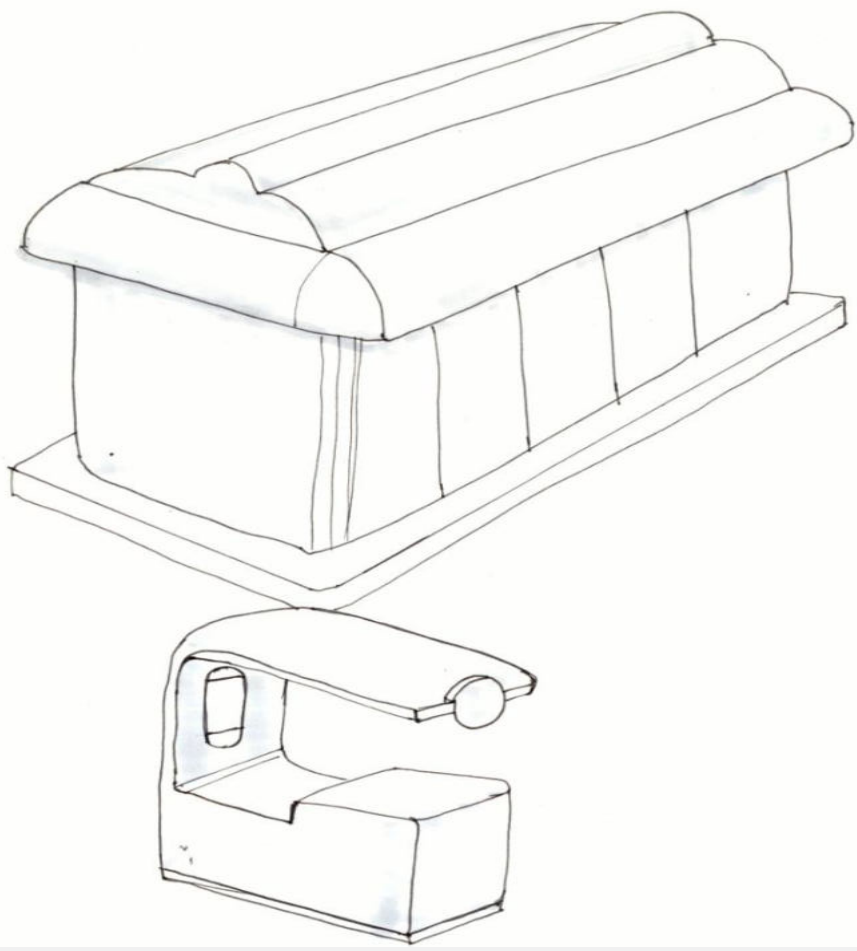

Light weight and modular nature

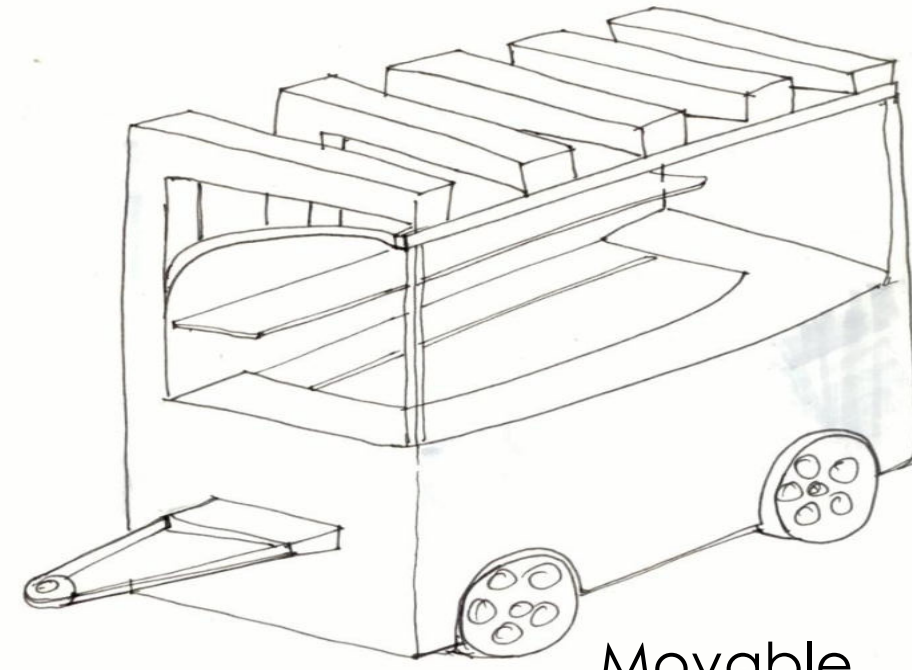

Movable

Litter bin

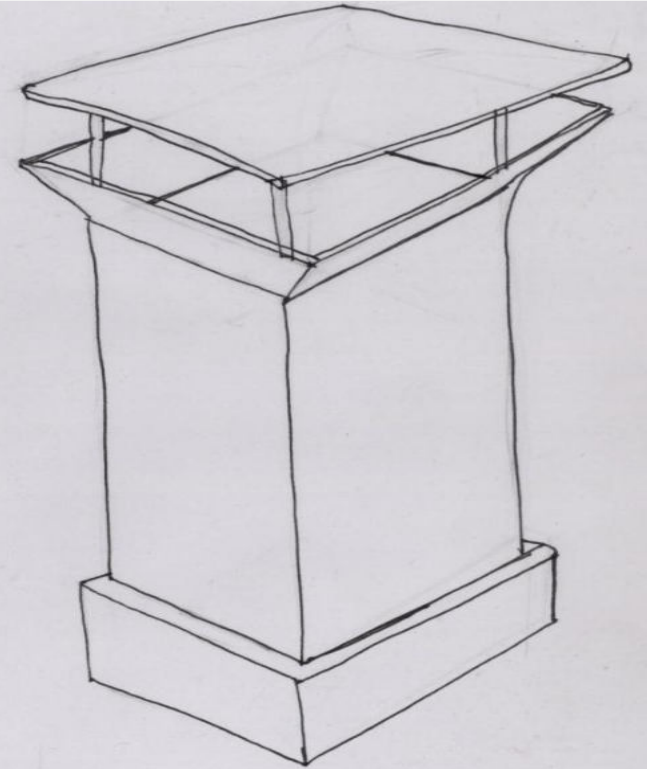
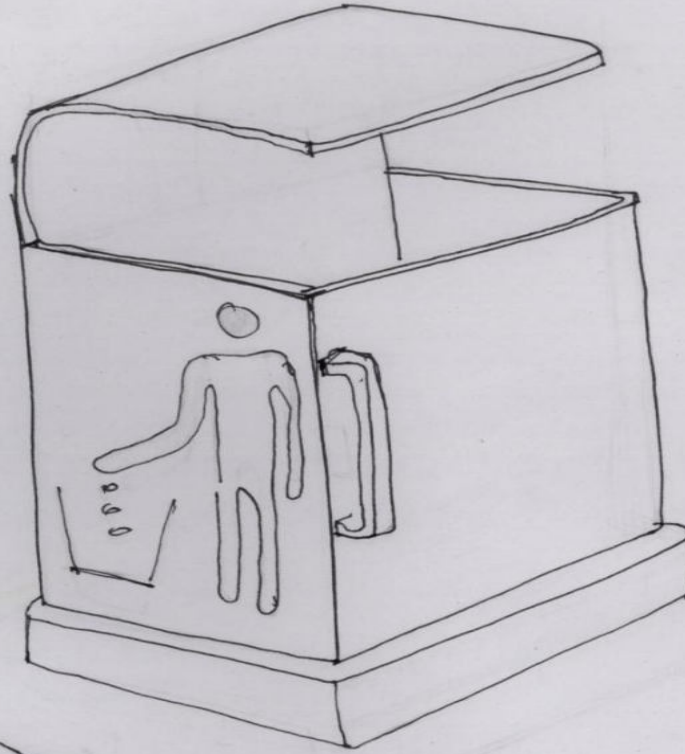
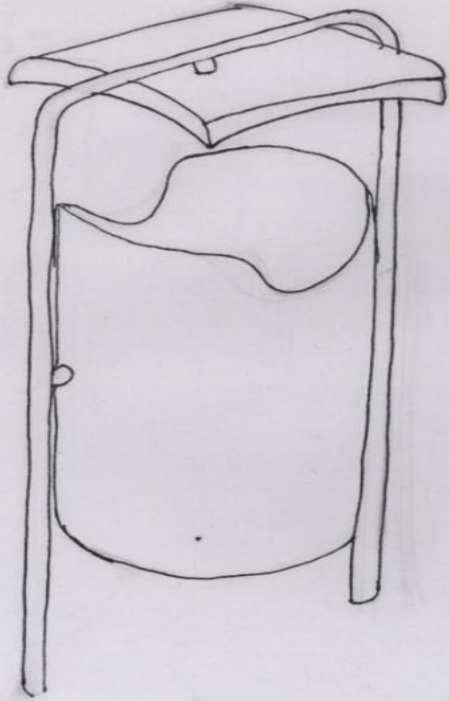

Easy to put in
and remove
the wastes
Stable and
vandal proof

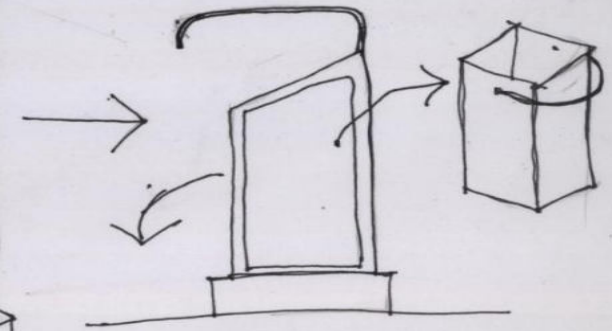
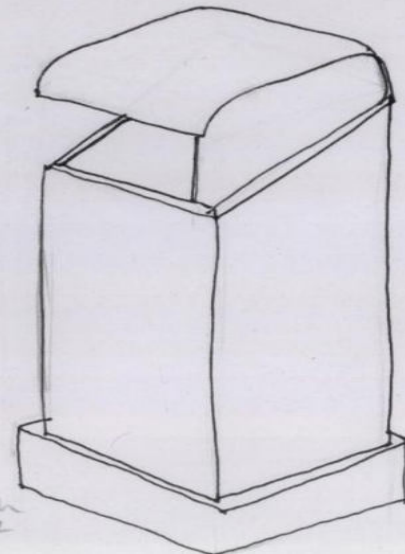

Vandalism
proof

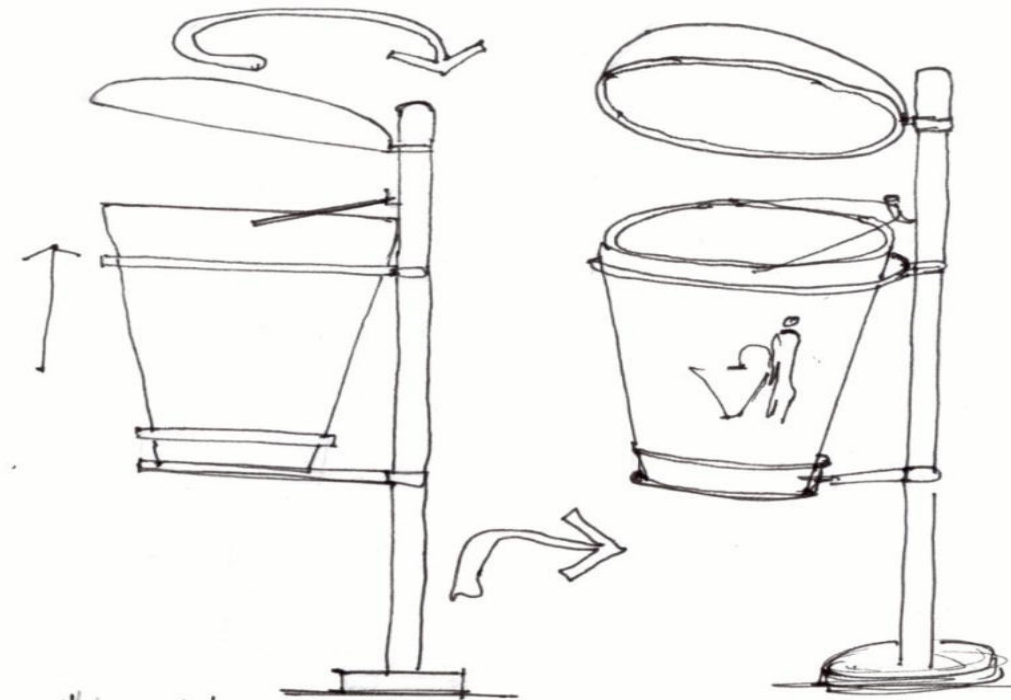
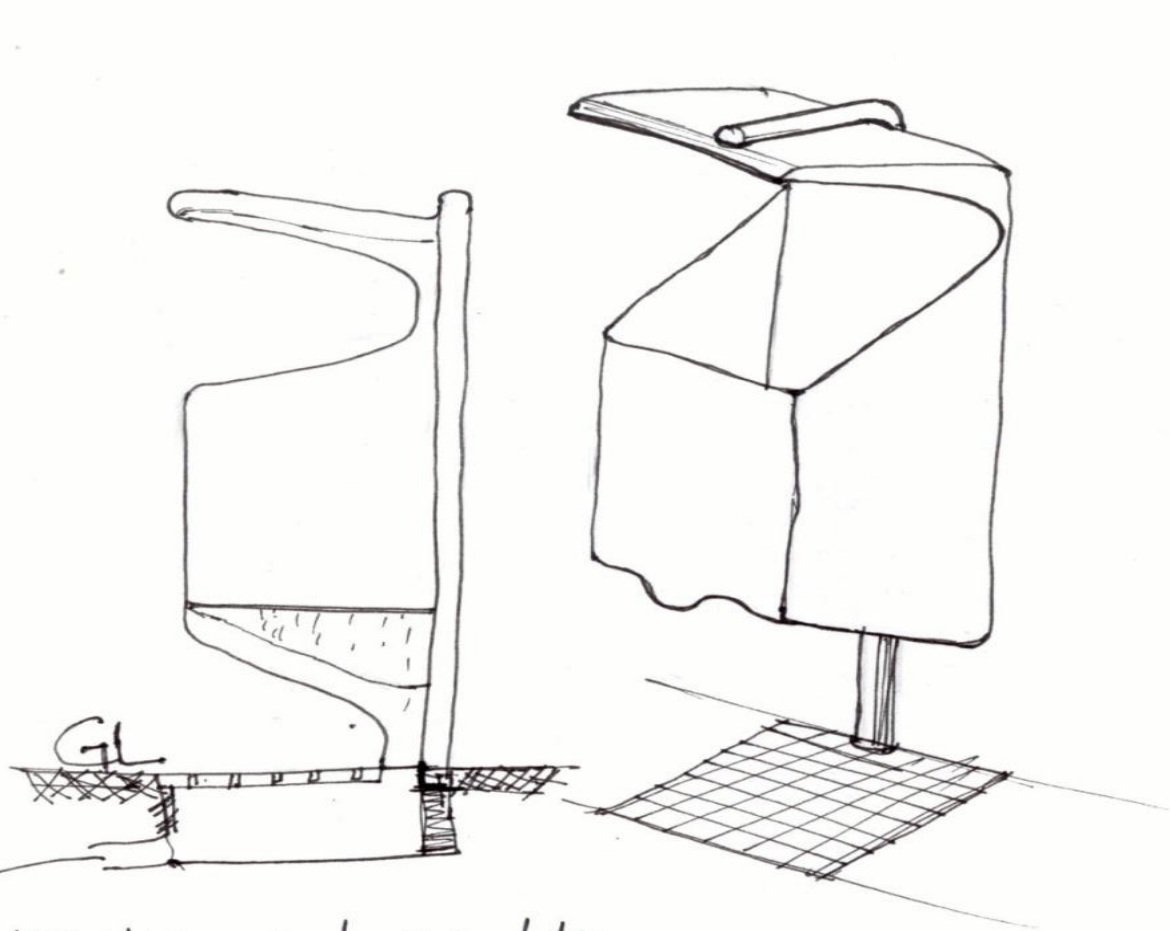

FLIP the top cover
~~to~~ to Remove the
bucket

* DRAINAGE under ground for
for some liquid
things

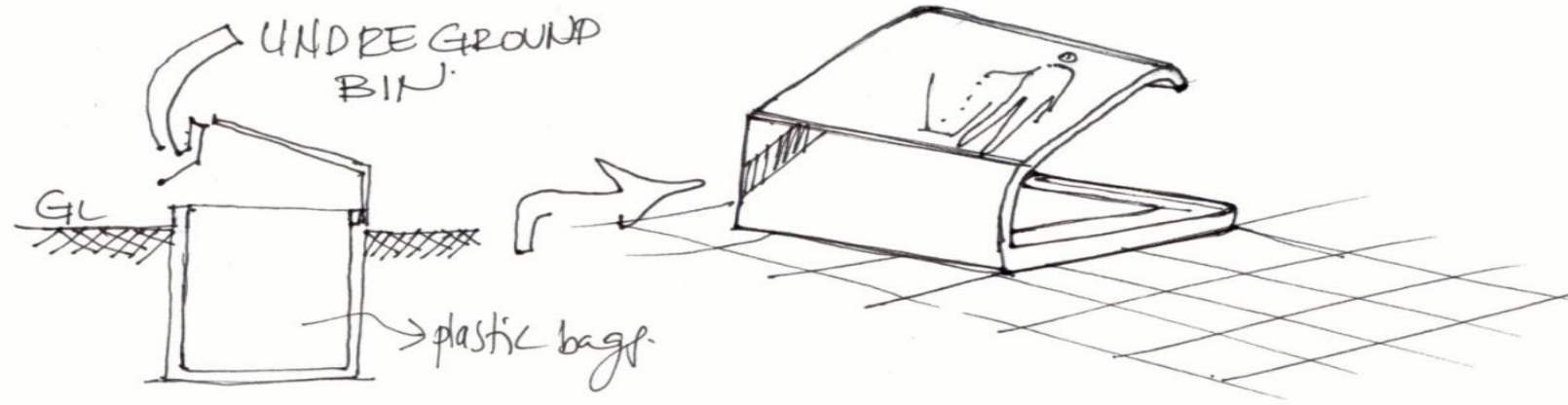

Bus queue shelter

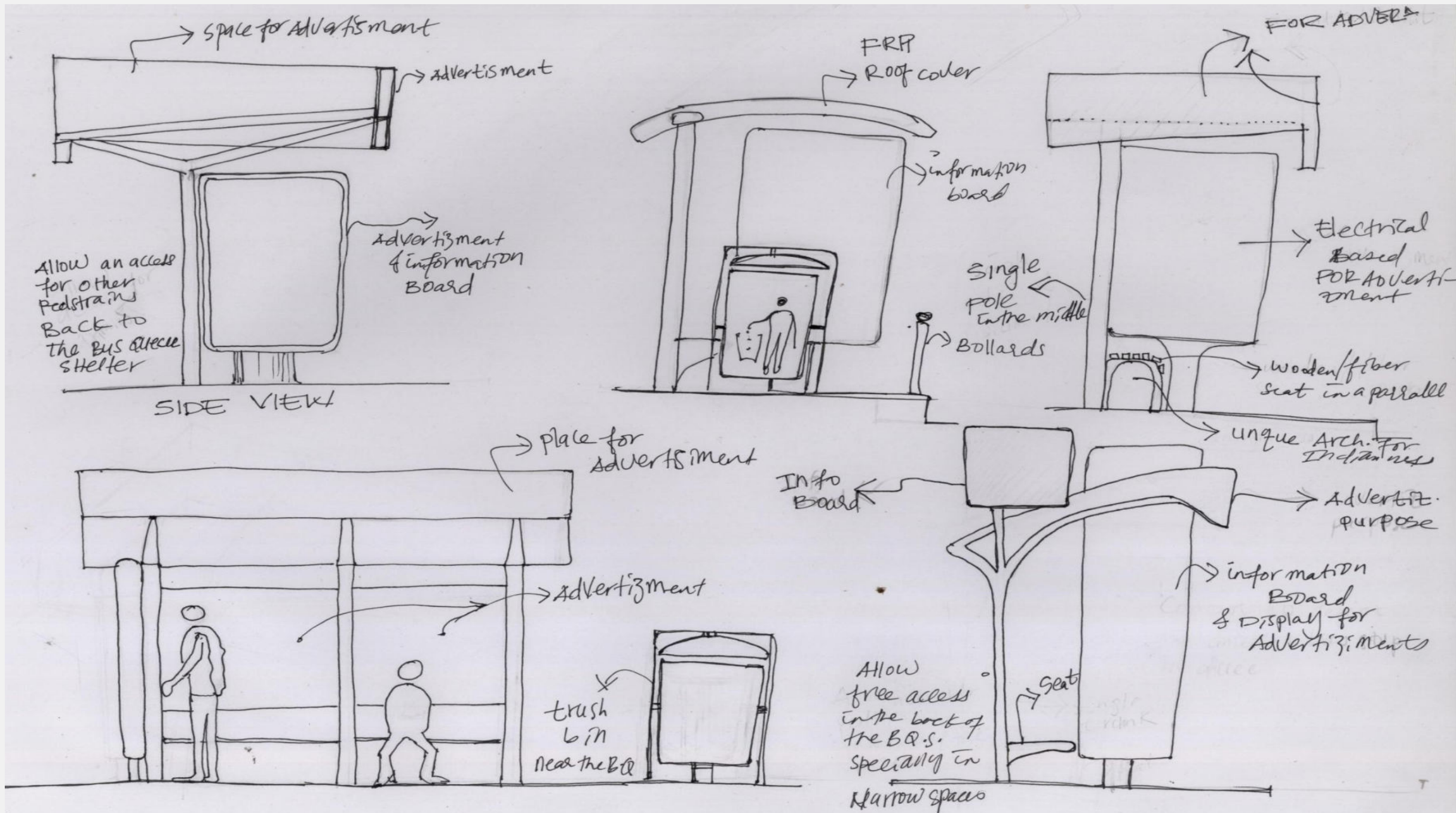

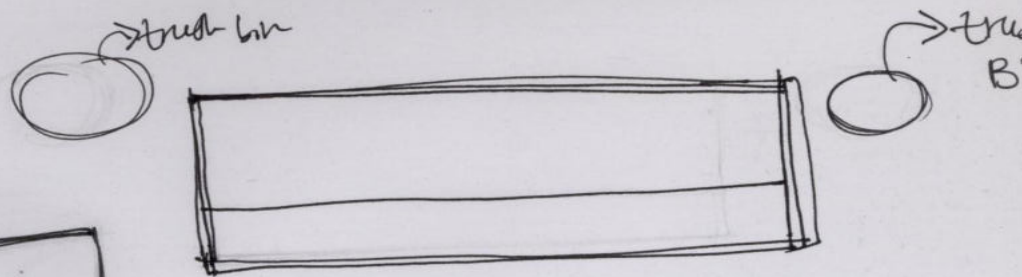
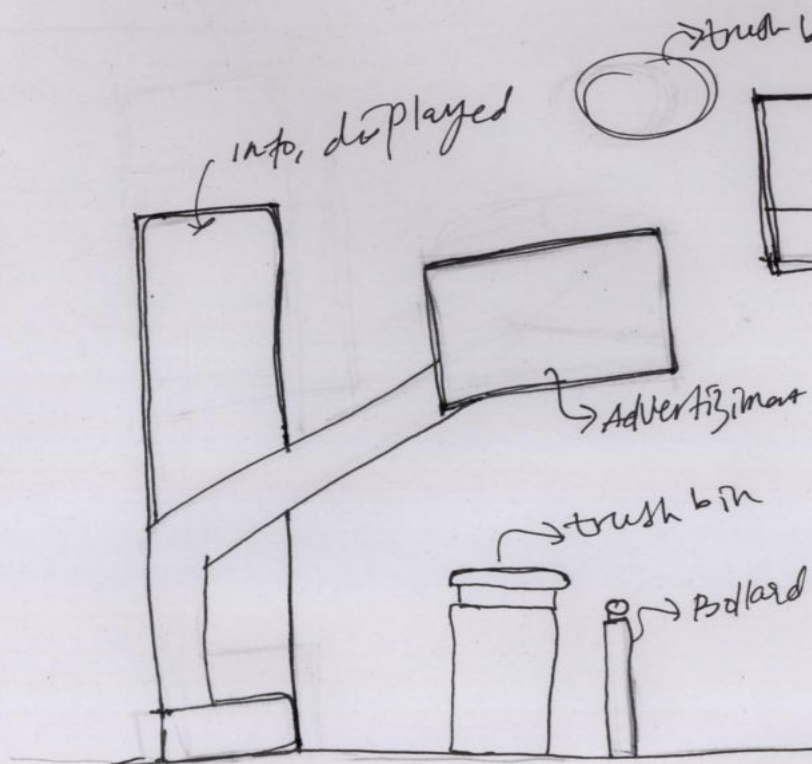
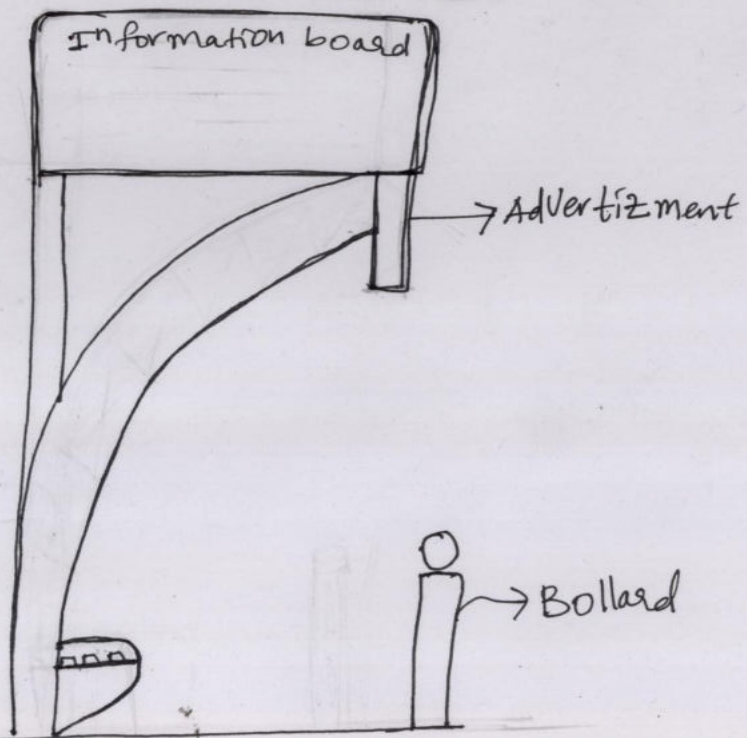
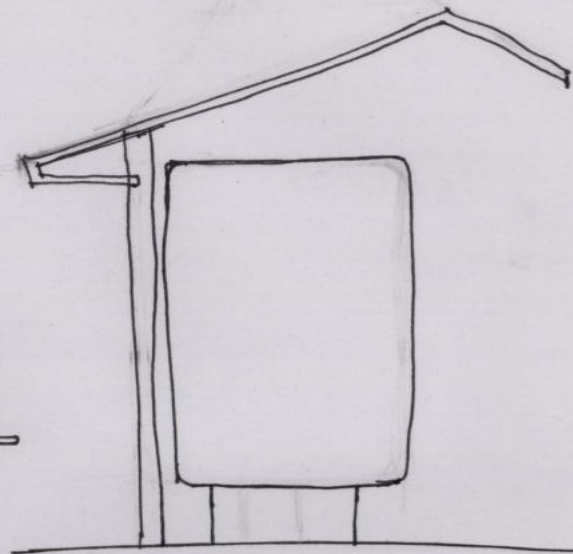
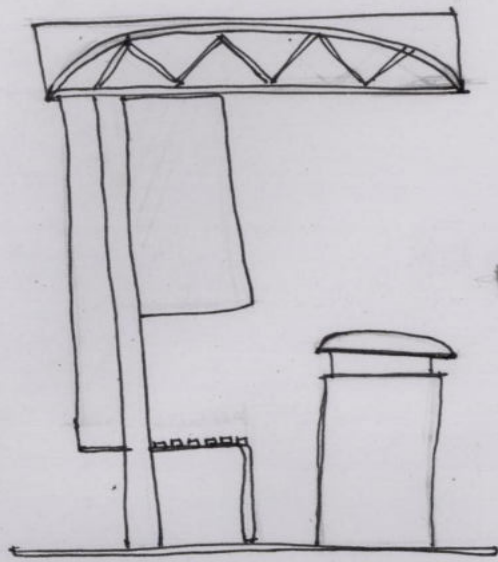
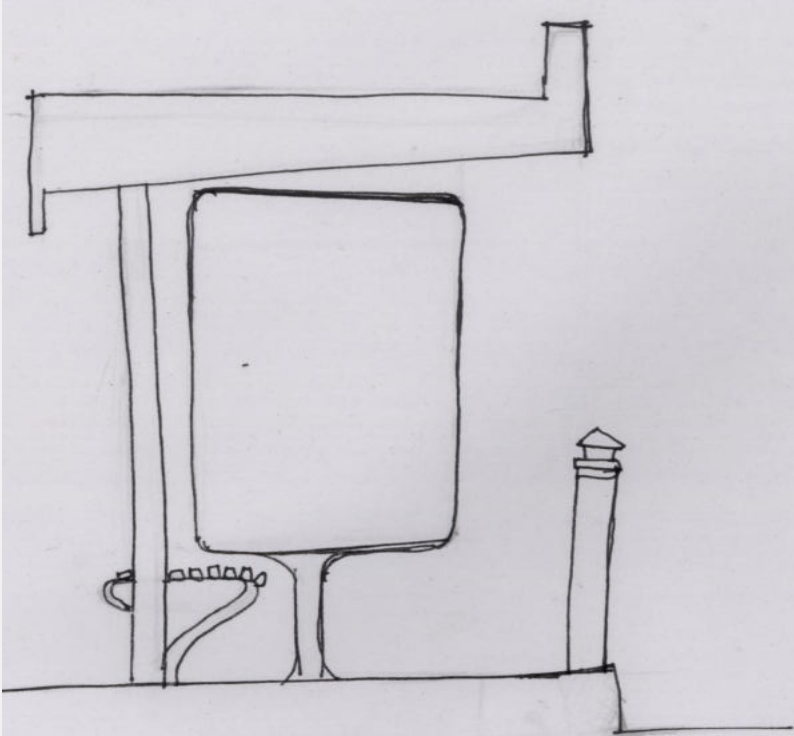

Information

ADVERTISEMENT

SOLAR PANEL FOR STREET LIGHTS

Advertisement

Bollard

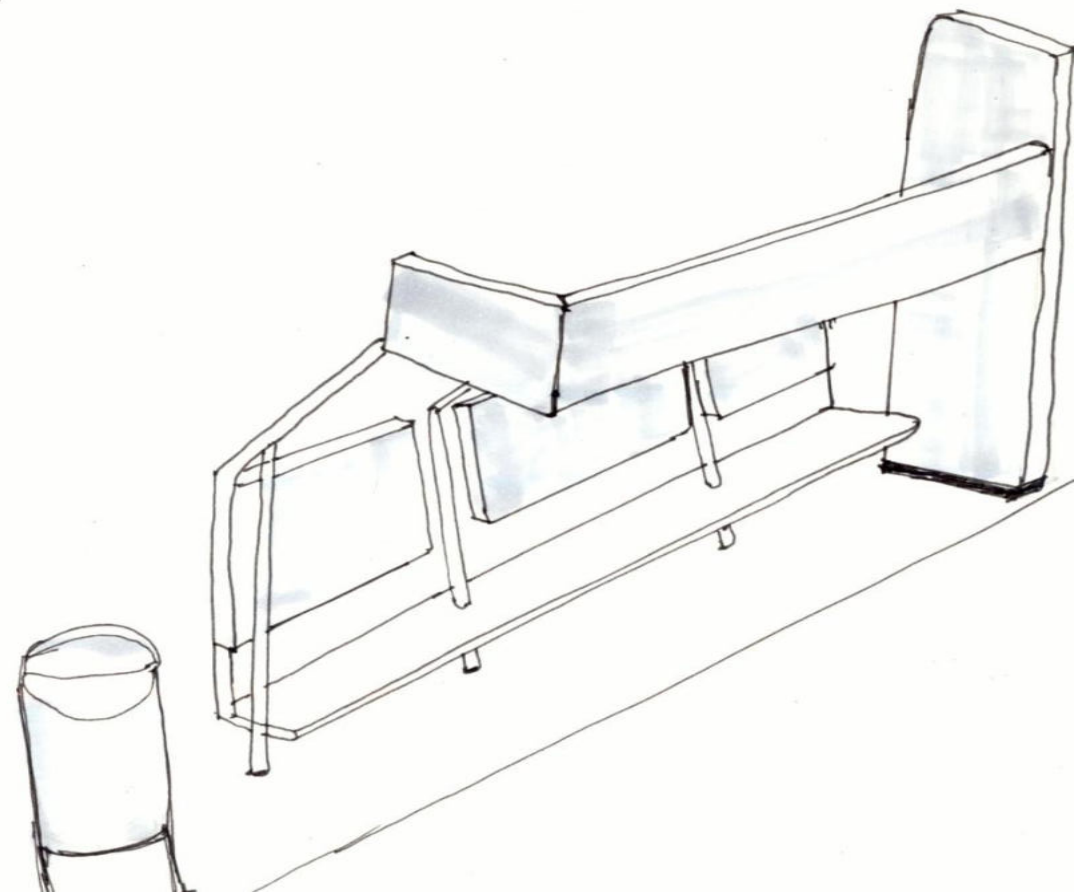
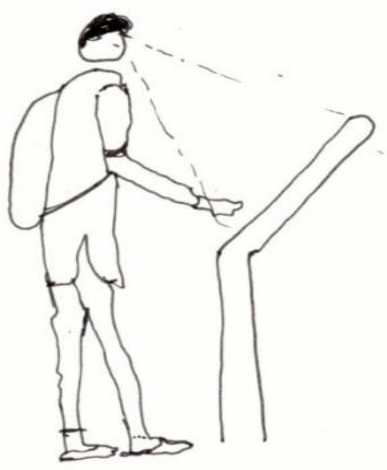
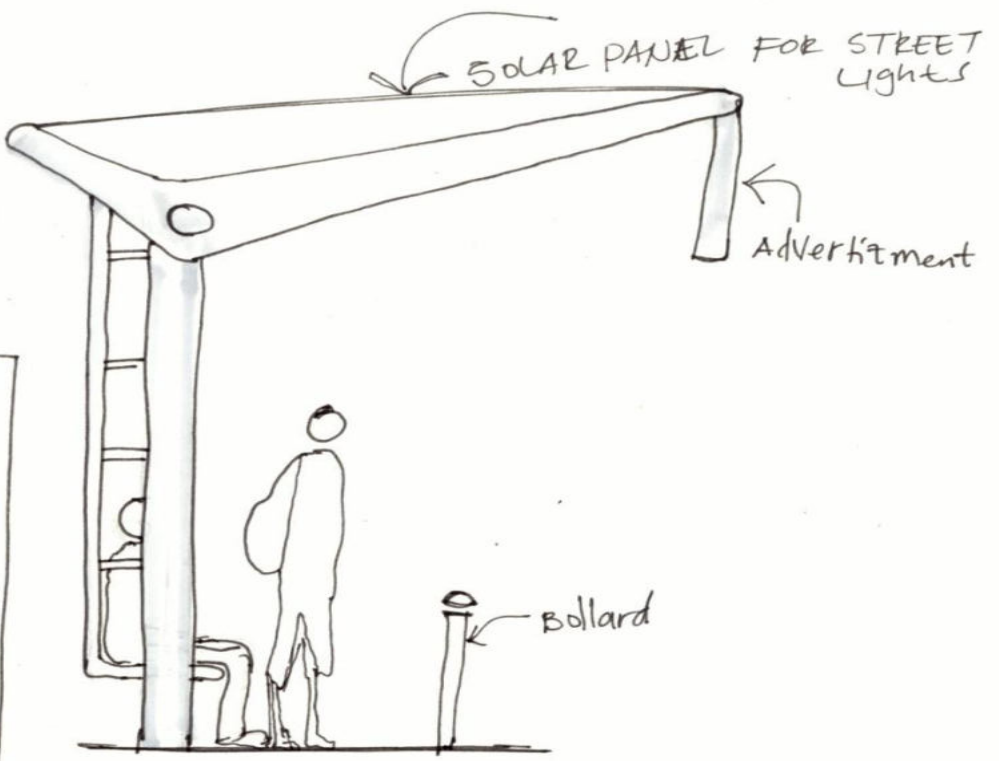
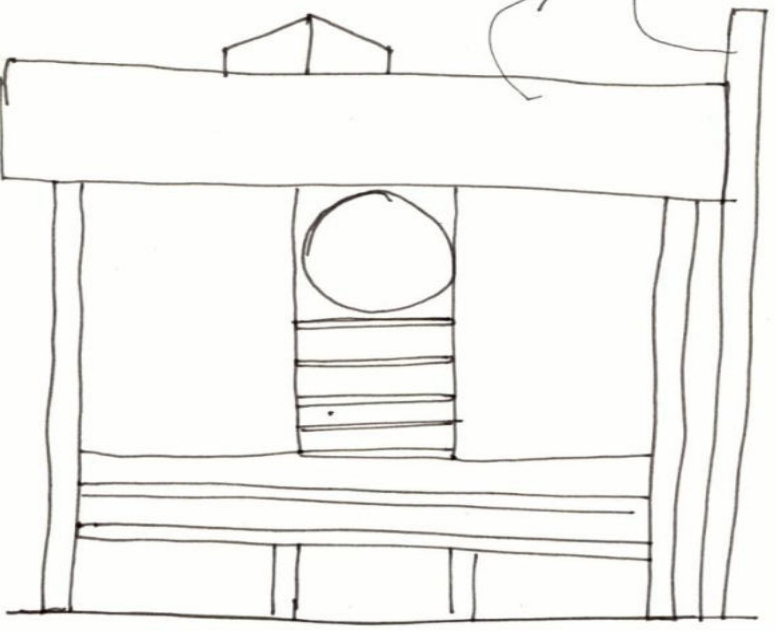

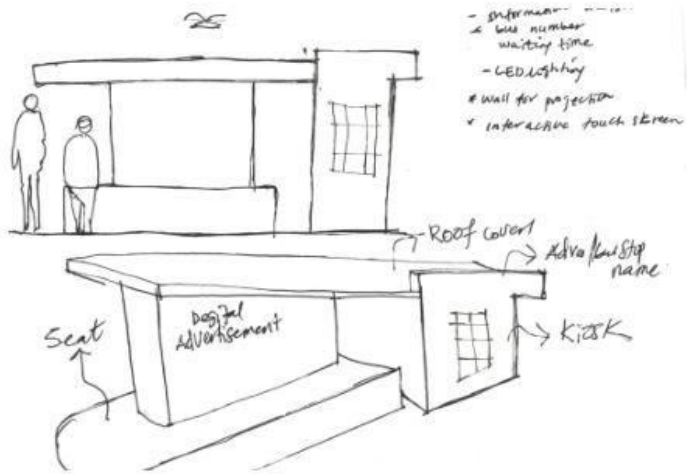
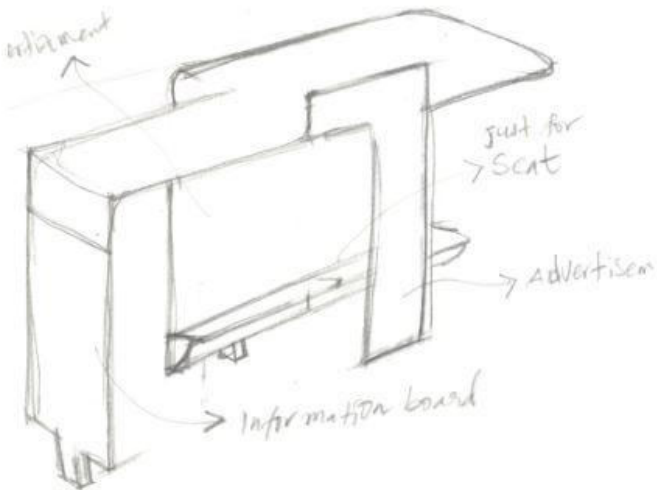
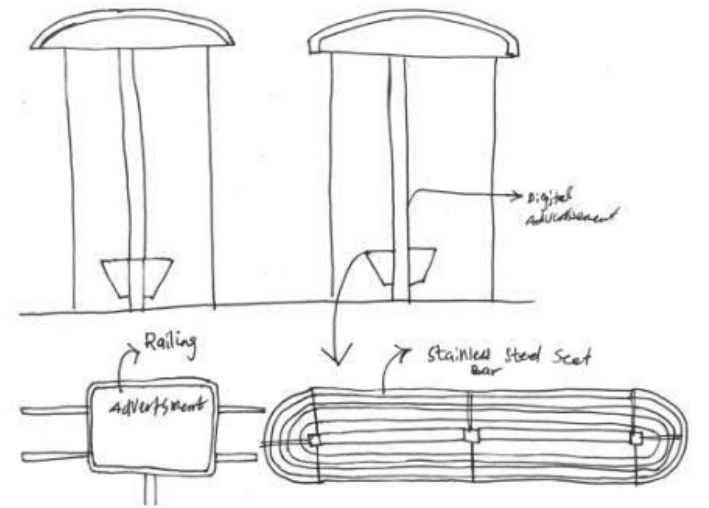
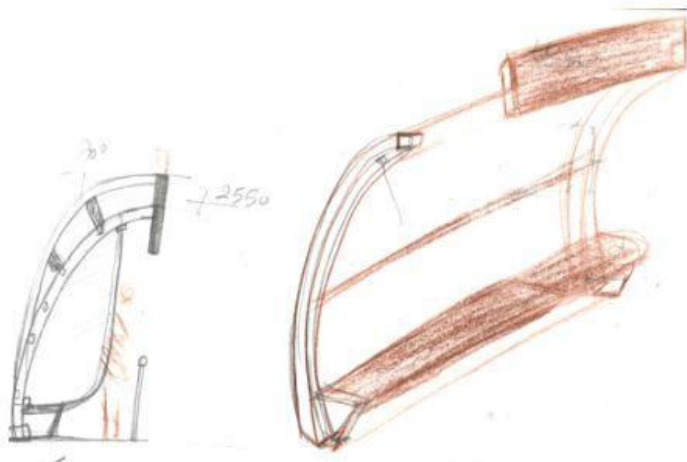
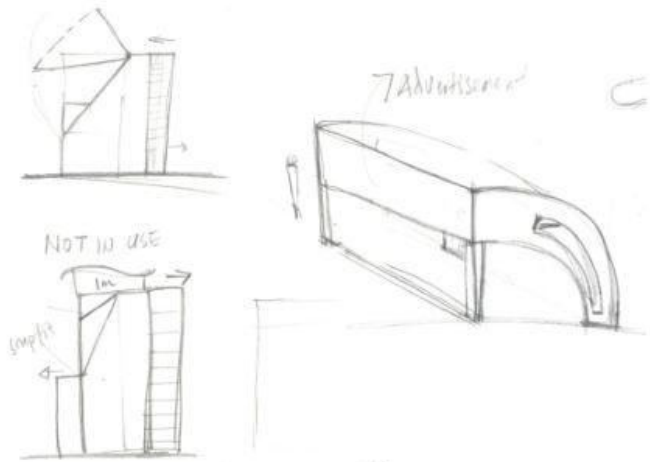
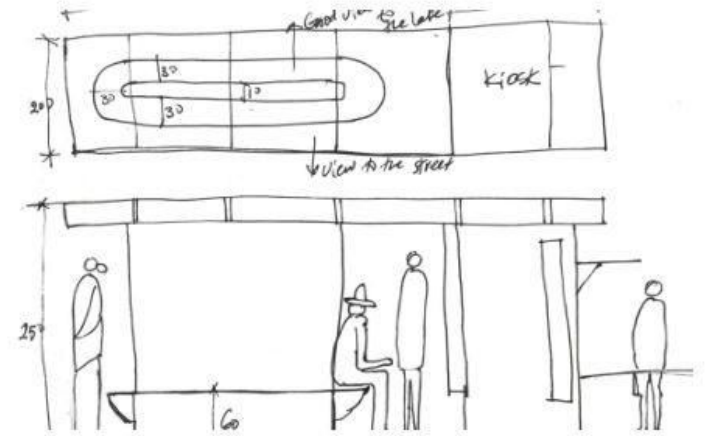
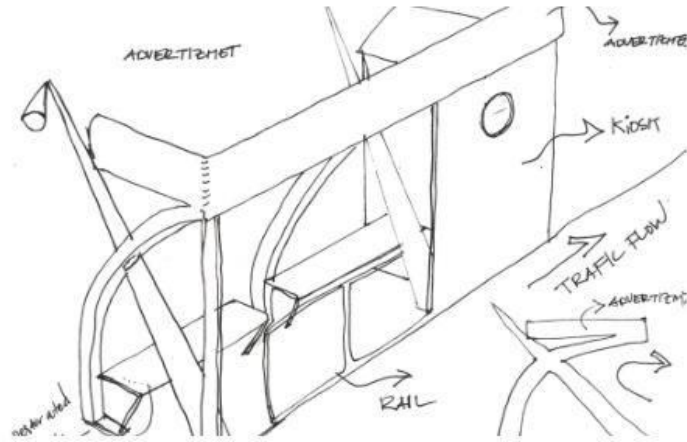
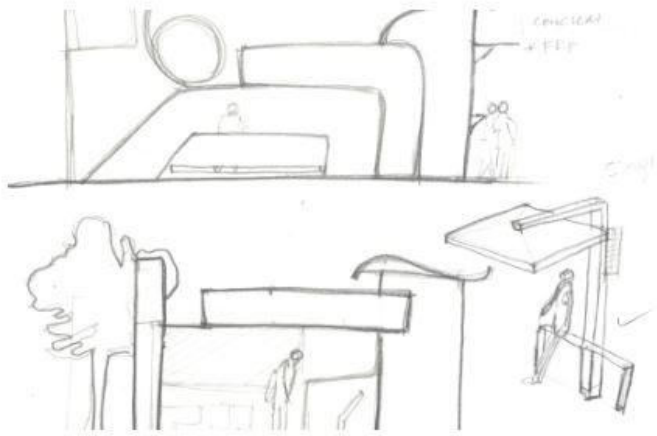

- Information
- bus number
- waiting time
- LED lighting
- wall for projection
- interactive touch screen

Figure 42 Bus stop

Public convenience

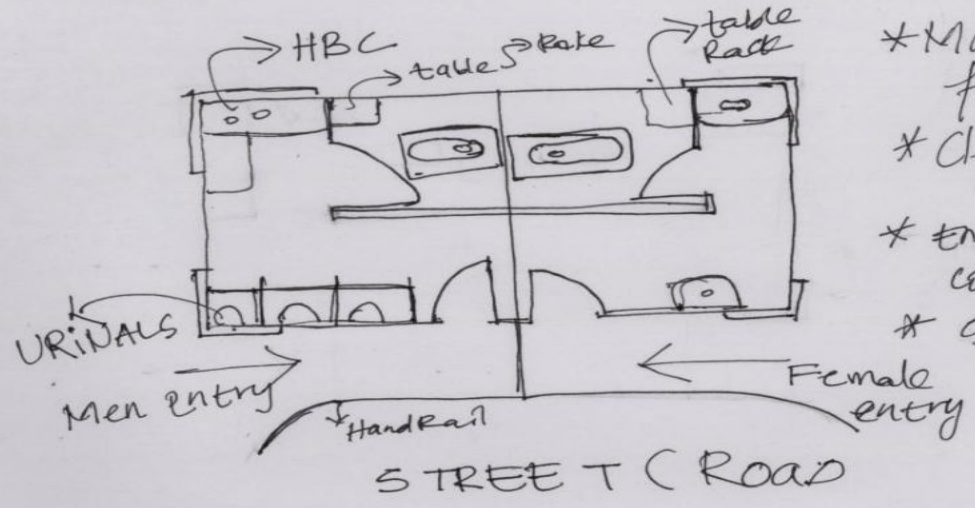
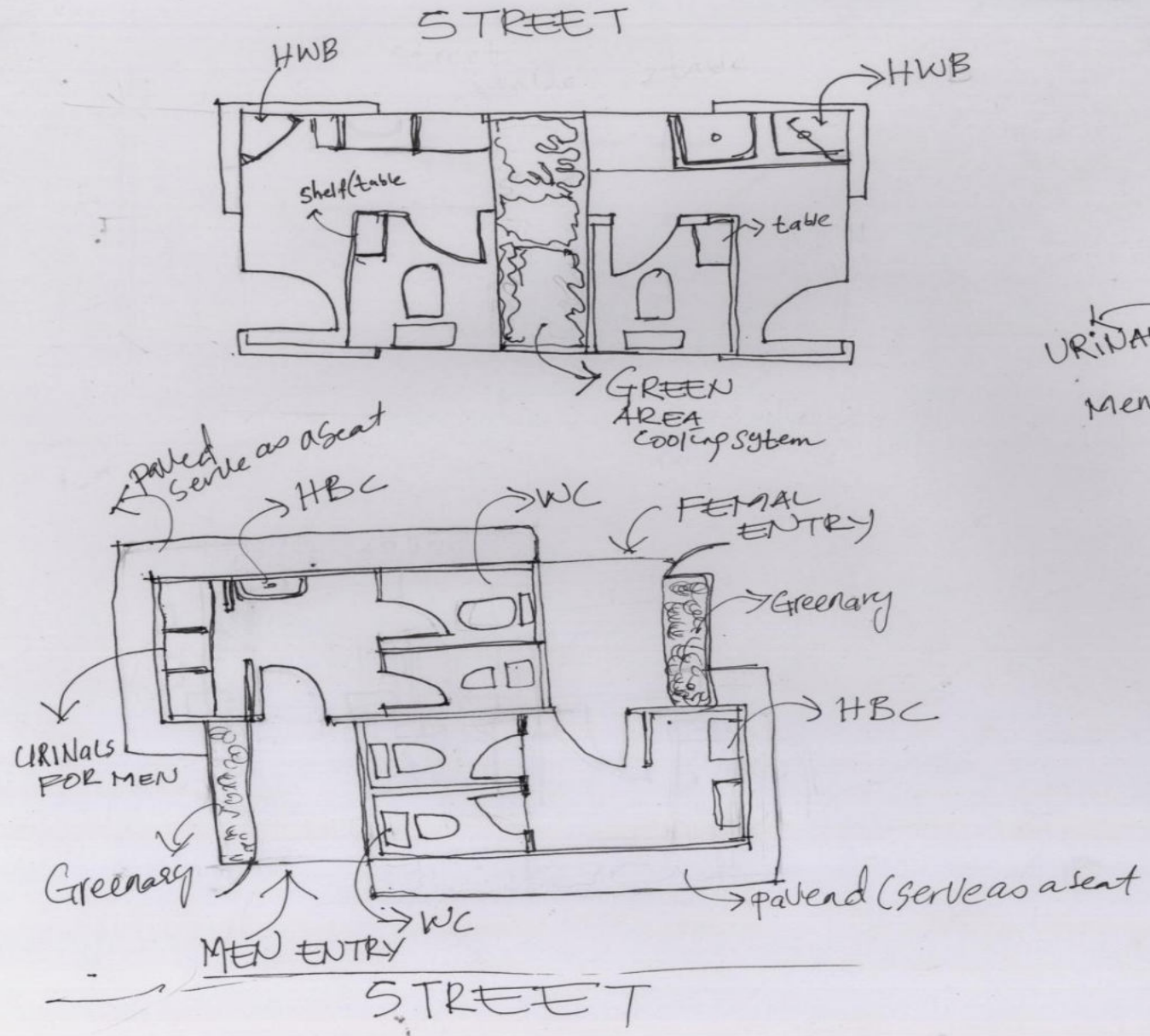

- * Make user friendly
- * Clean look
- * Environmental considered
- * Secure & safe

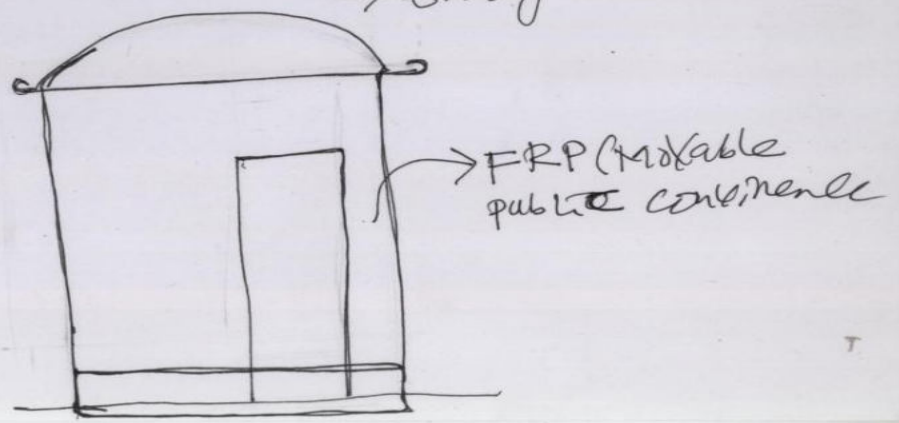
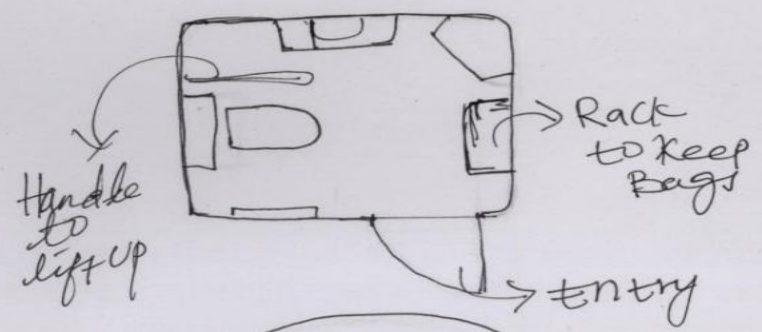

Bollards

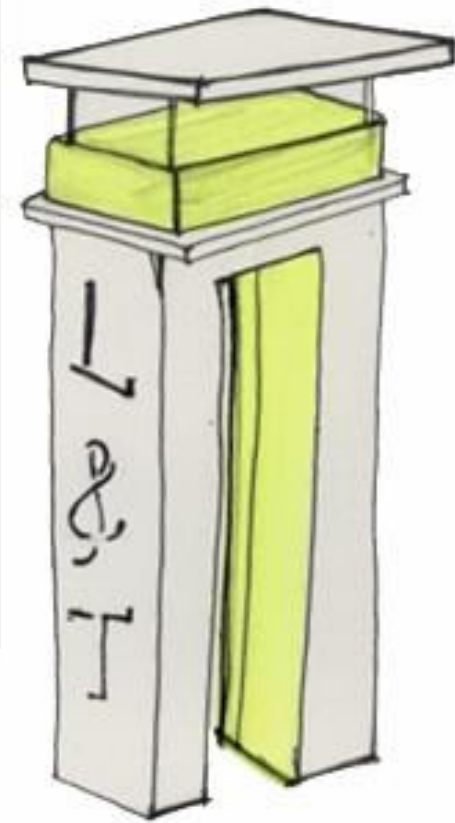
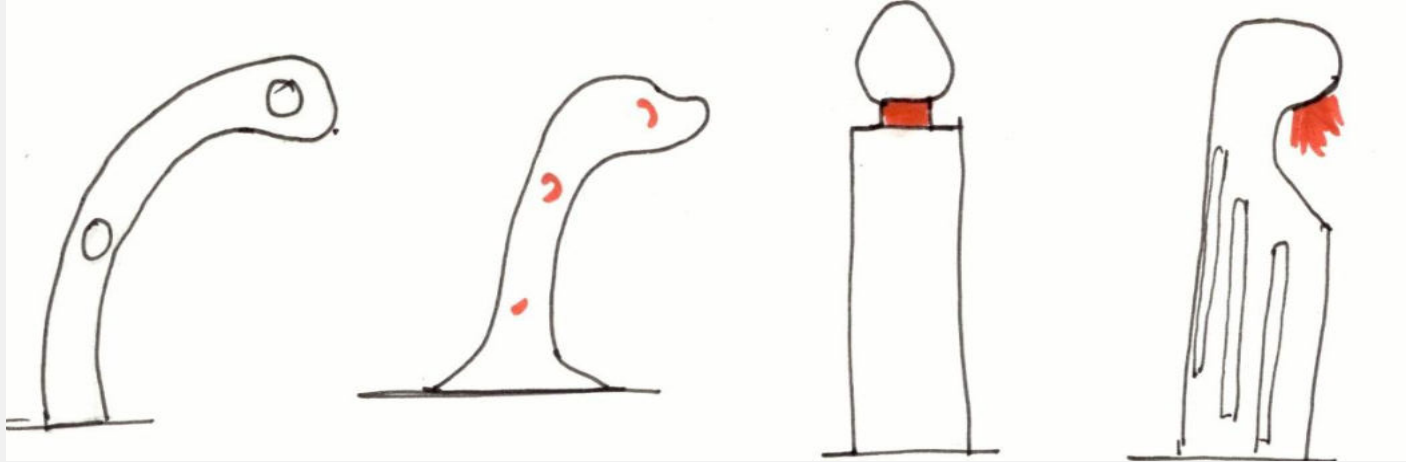
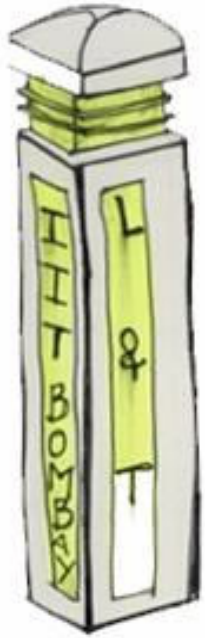

- Iconic
- Stable
- Reflector light

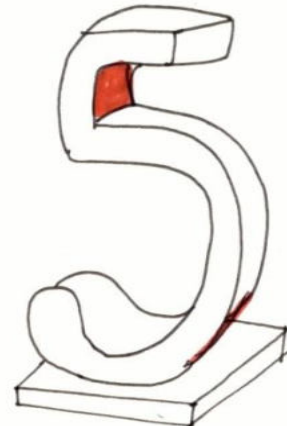
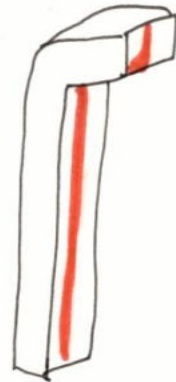
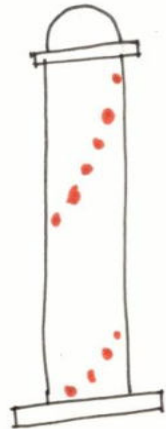
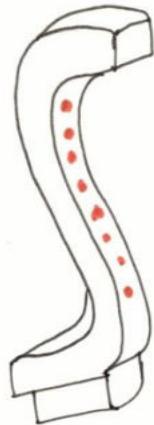
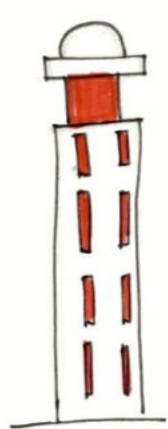
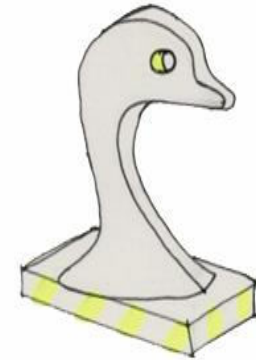
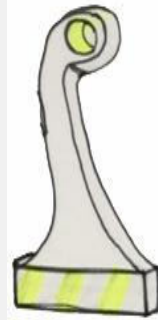

Direction boards

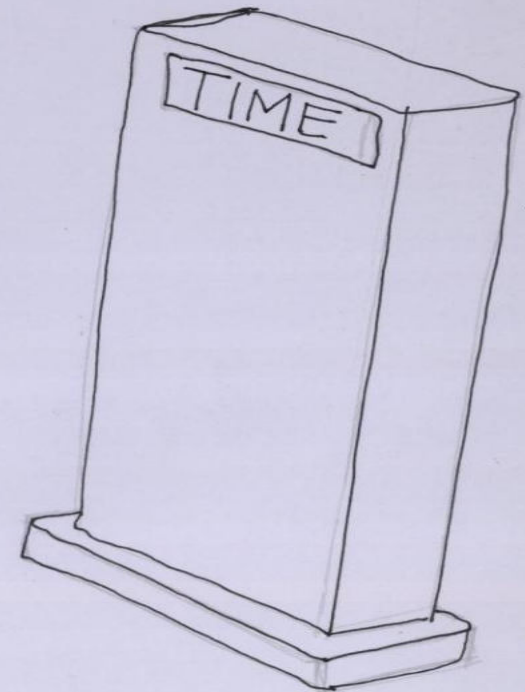
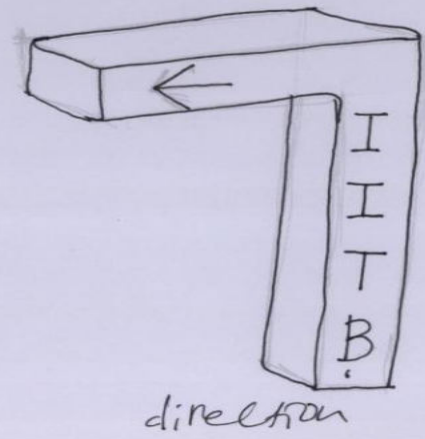
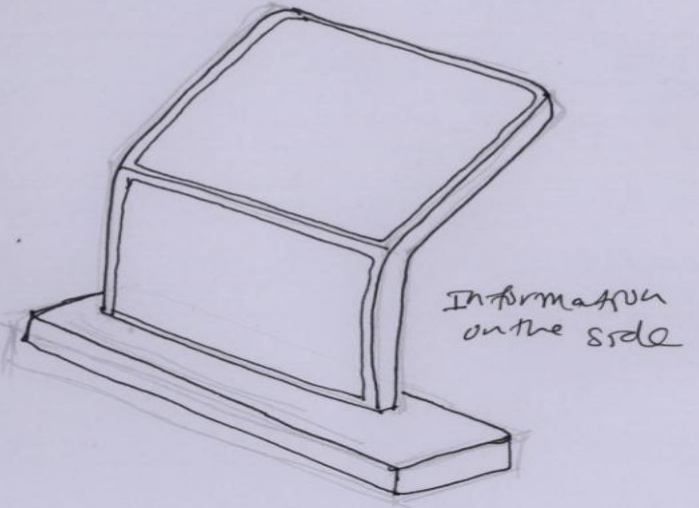
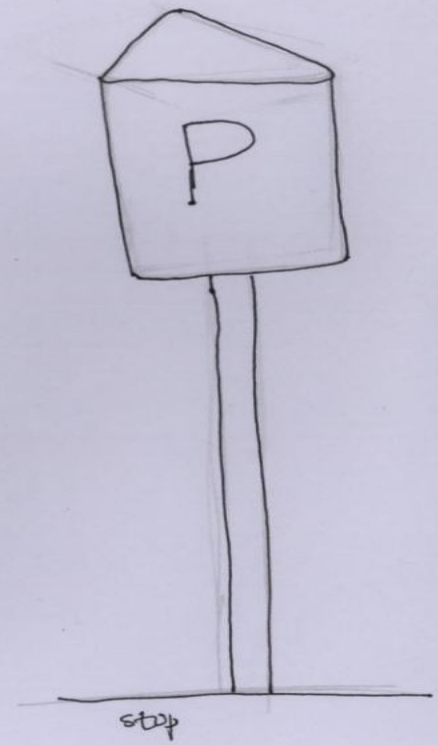
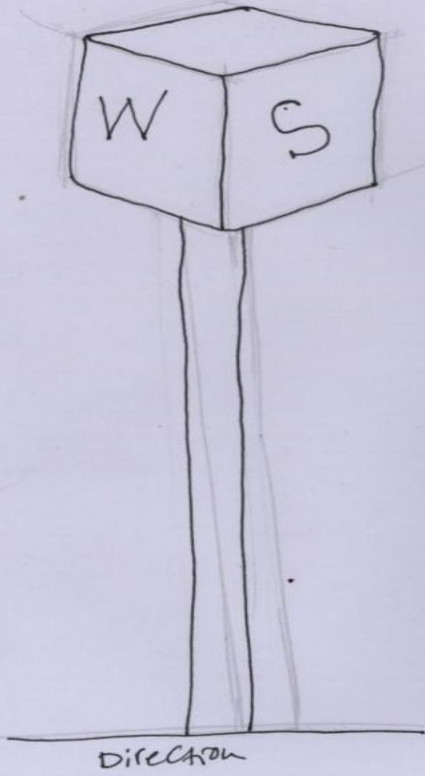

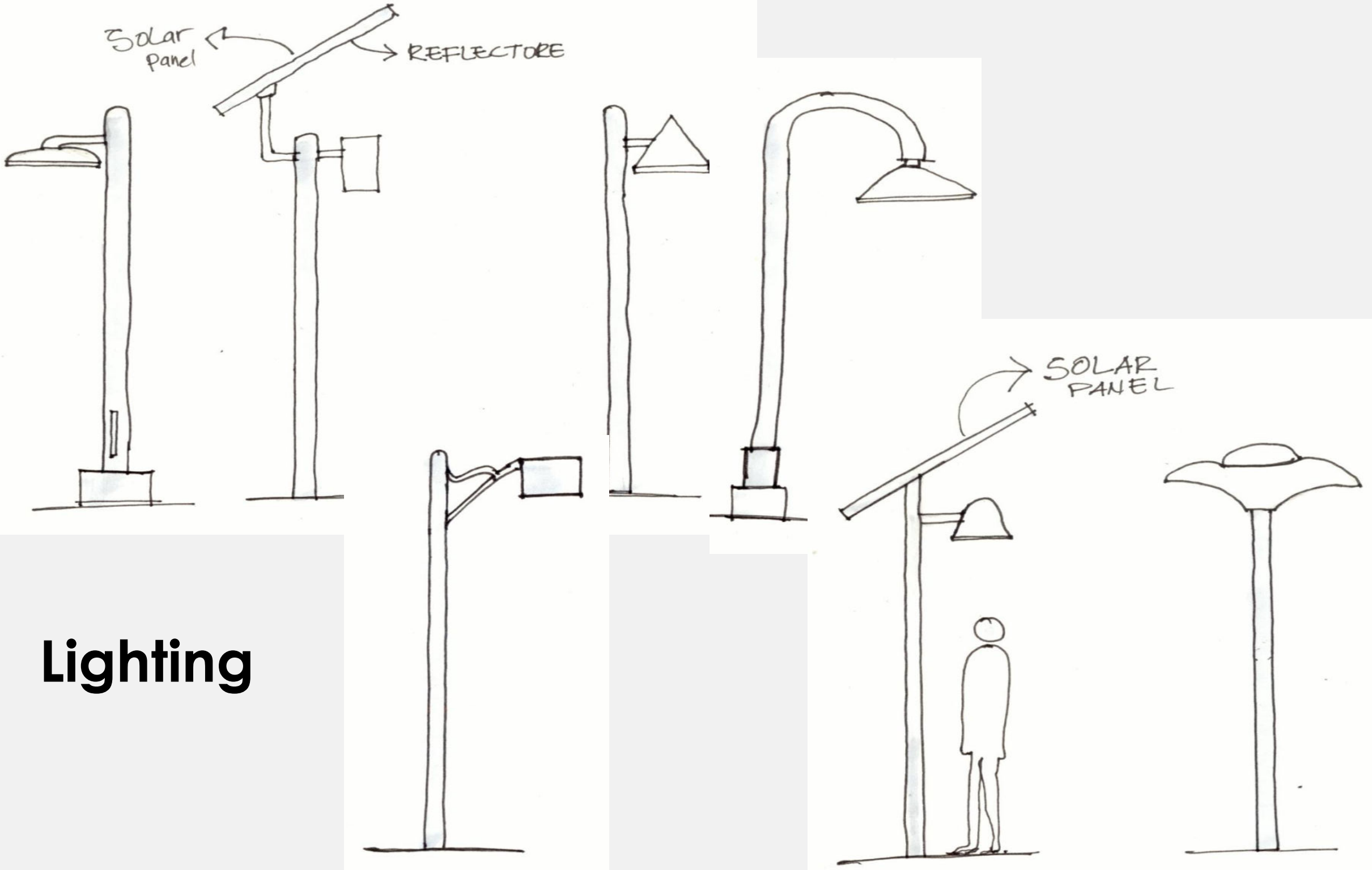

Solar Panel ← REFLECTORE

SOLAR PANEL

Lighting

How the furniture look same family

- Using same material for all furniture
- Use common shape/form/ elements in all
- Color of the furniture give family-ness
- Conceptual/semantics applying in all the furniture, such as high tech-ness, modern, classical, contemporary

Modern

- Optimum and elegant in form and detail
- Ergonomic and organic shapes
- Rectangular with filleted edges,
- Smooth surfaces/edges, soft look

Design language around "Powai" street

- Free flow forms/shapes
- Combinations of arcs and lines
- Repetition of elements
- Playful and recreation
- Reflection and movement
- Contemporary look

Concept development

1. Benches



- Simple
- Economical
- Usable

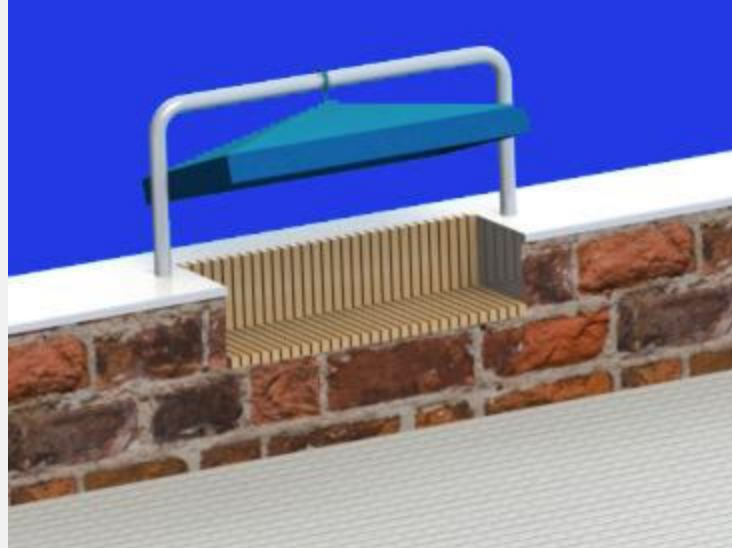

- Simple
- Comfortable in public places
- economical



Playful but unsafe



- Simple,
- usable

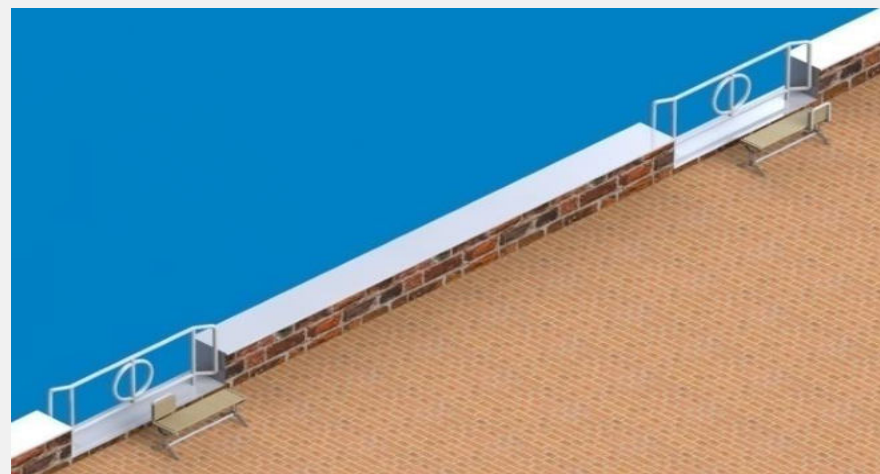

- Allow to see to ward the lake
- Break the chaos of the barrier



- Simple
- Fit to other places



- Stable,
- Allow to sit in different directions



Elegant, and unique



Stable, practical, comfortable



Practical



Practical, usable, comfortable



Adjustable back rest Allow to see in to different directions but looking heavy

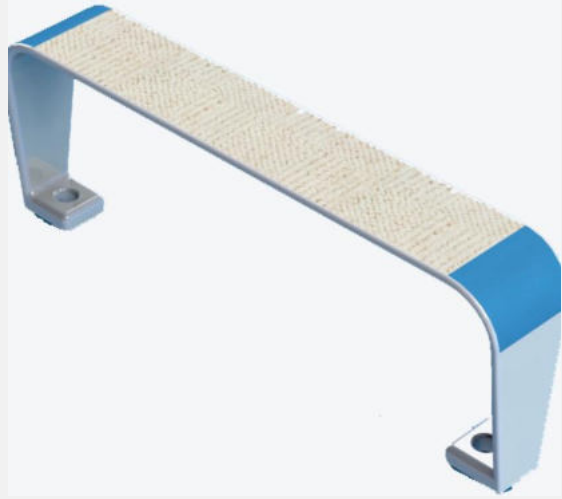

- Simple, elegant
- Can be used in Bus stop

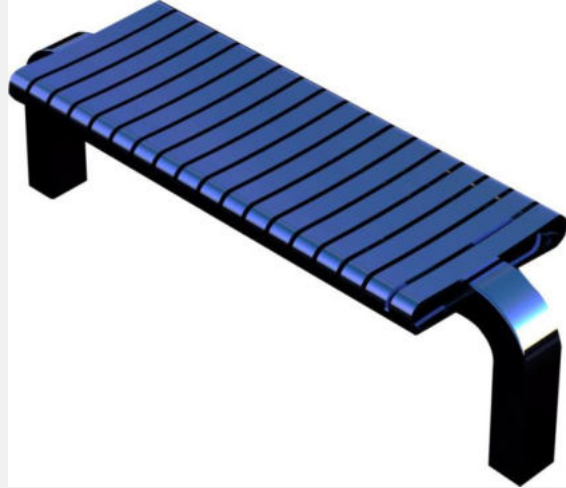

- Practice
- Durable
- Corrosion resistant



- Simple ,
- Can be used in bus stop
- Durable and practical



- Simple, elegant, practical



Elegant,



- Iconic,
- Provide save for advertisement

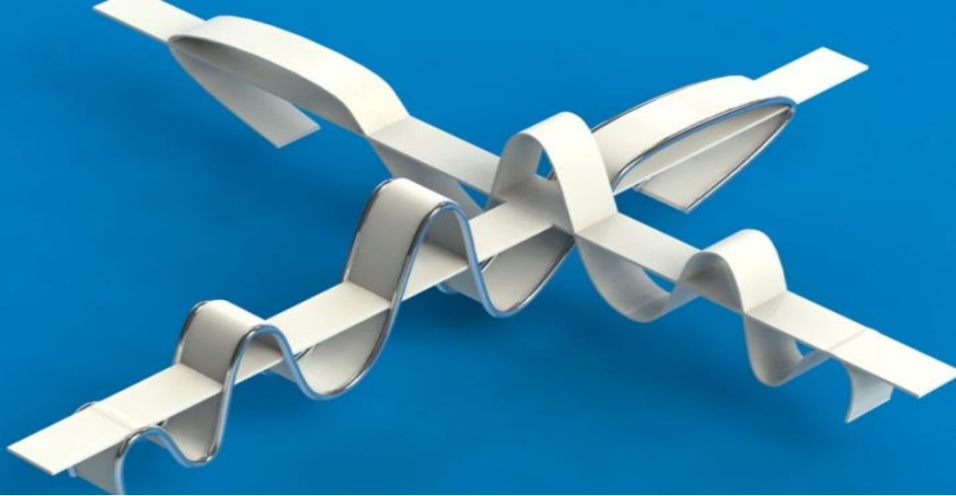

- Allow users to sit in group
- Different sitting posture



- Allow users to sit in group



- Allow users to sit in to both directions
But massive

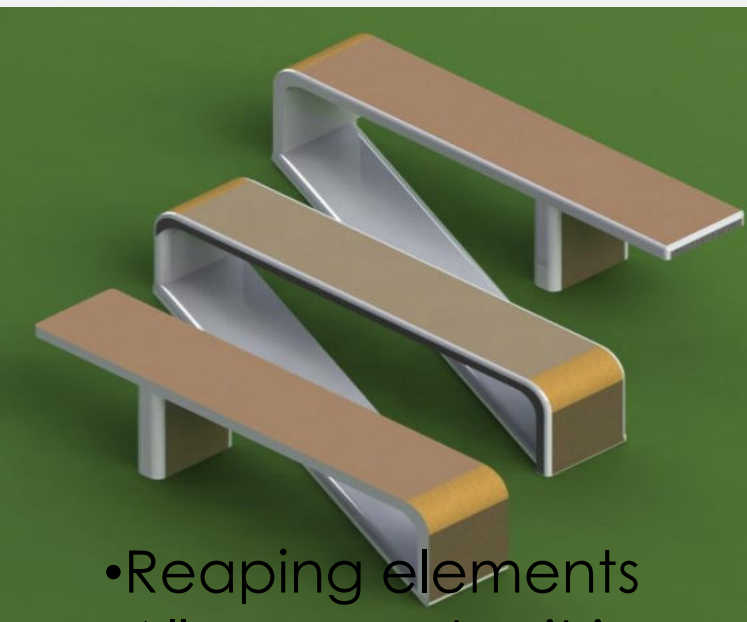

- Reaping elements
- Allow users to sit in group



- Playful

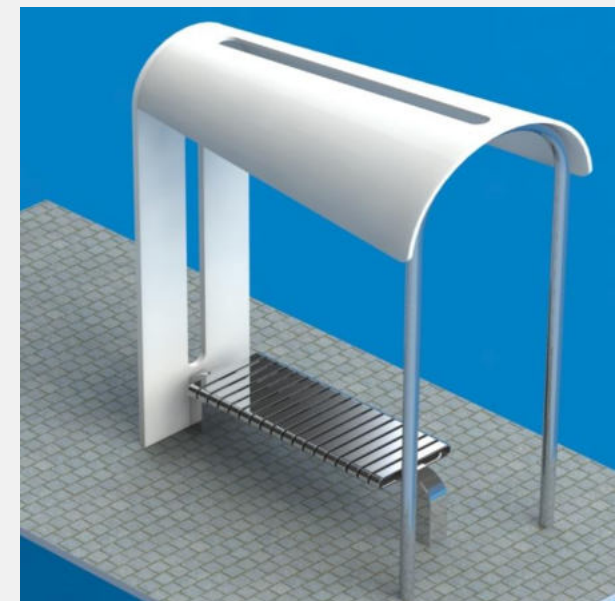

- Bench with sunshade



Comfortable, Playful and simple



Durable, usable
stable, Sturdy and
practical,

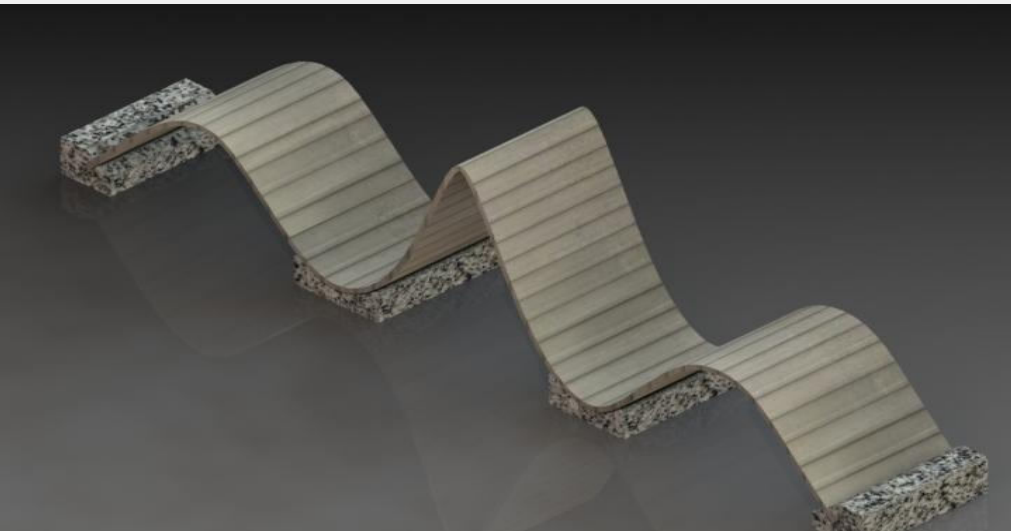

Allow to sear sleep and relax



Durable,
light weight



Just to seat a while



Stainless steel tube seat which is durable and usable



Simple, can be arranged in different positions

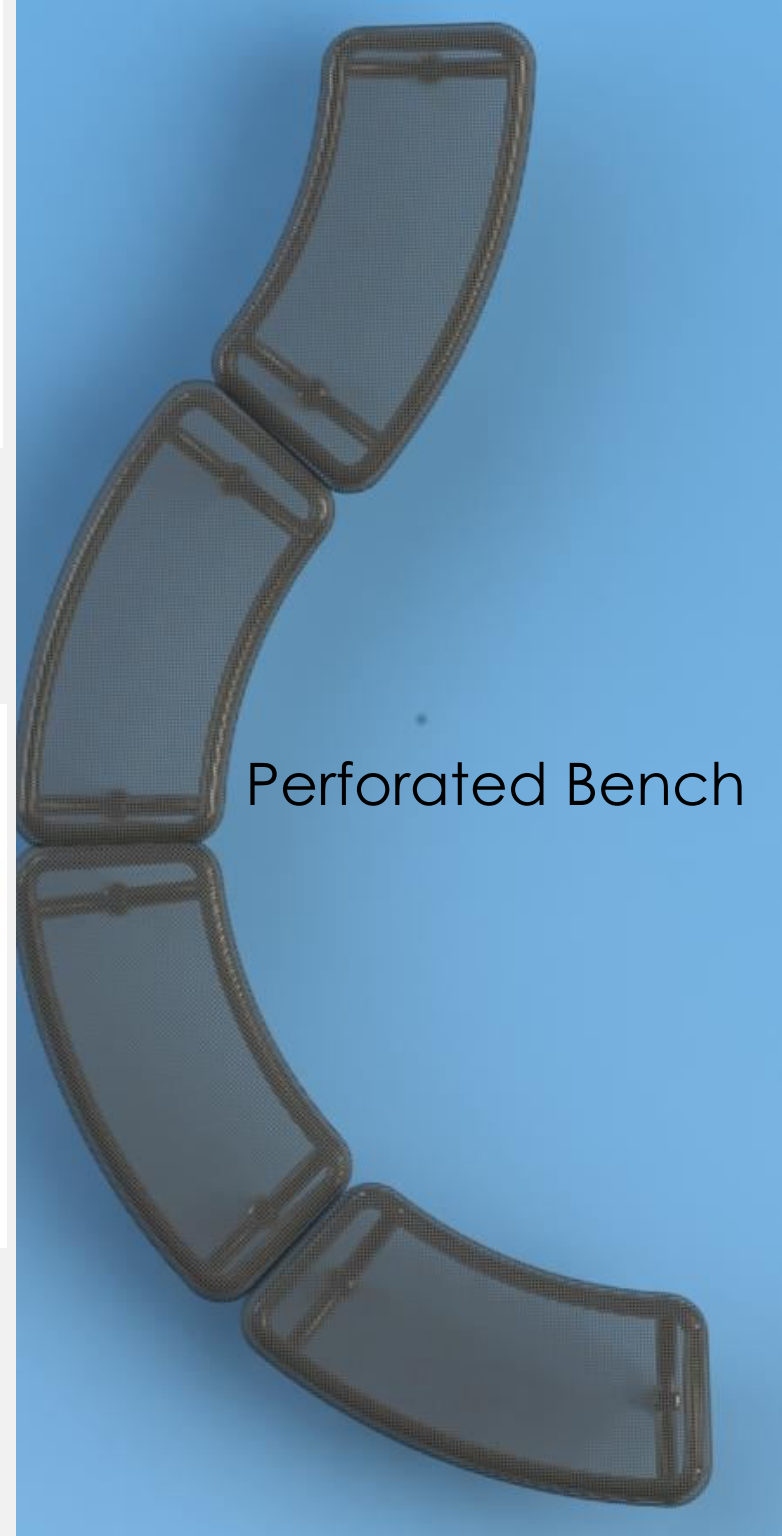

Perforated Bench

2. Bus Queue shelter

Bus stops are used

- As a shelter for the people while the buses are coming
- Land mark for a people to meet and stay for some time

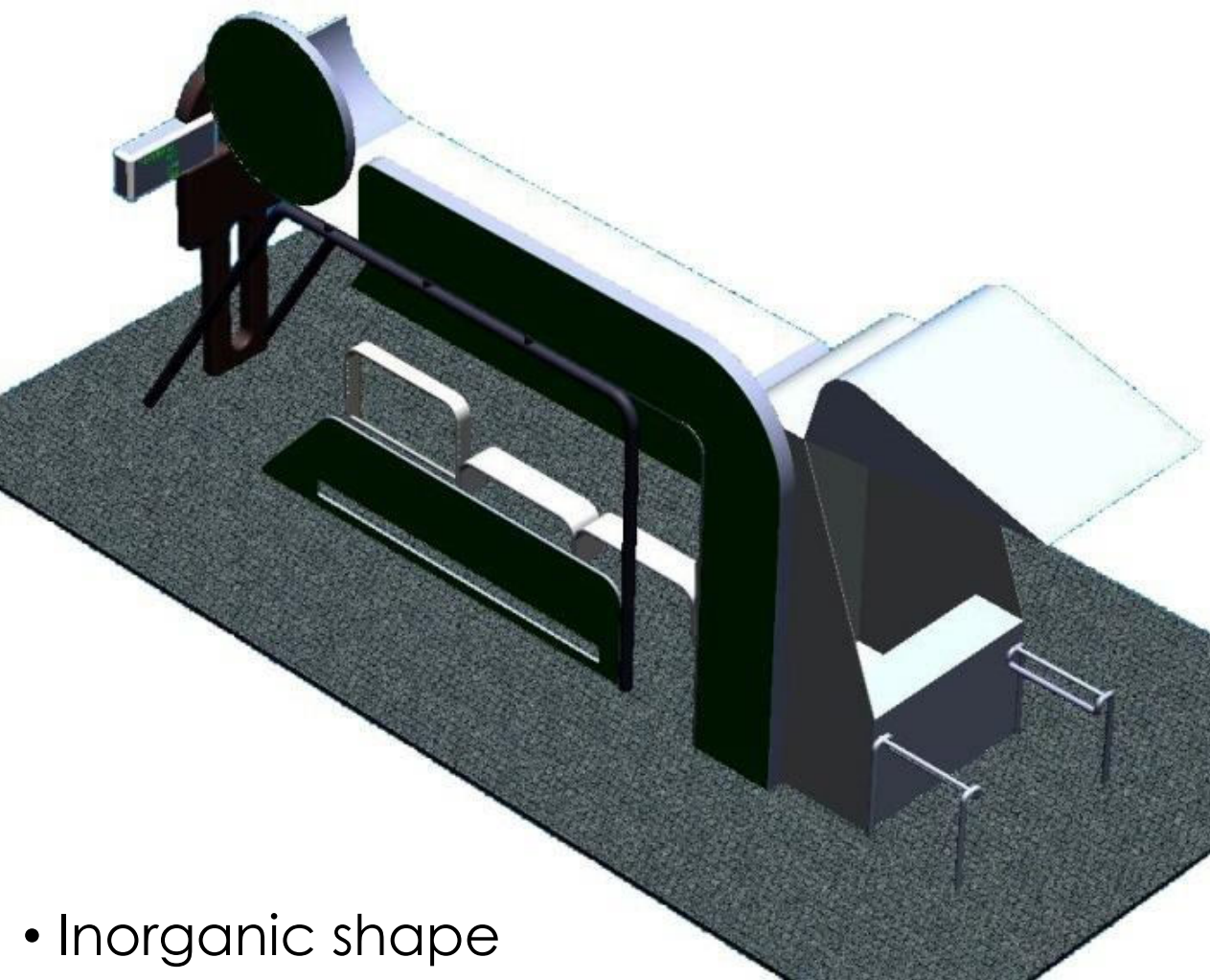

- Inorganic shape
- Digital bus information board
- Detected buses and tell how long it will delay,
But
- Looking heavy and massive

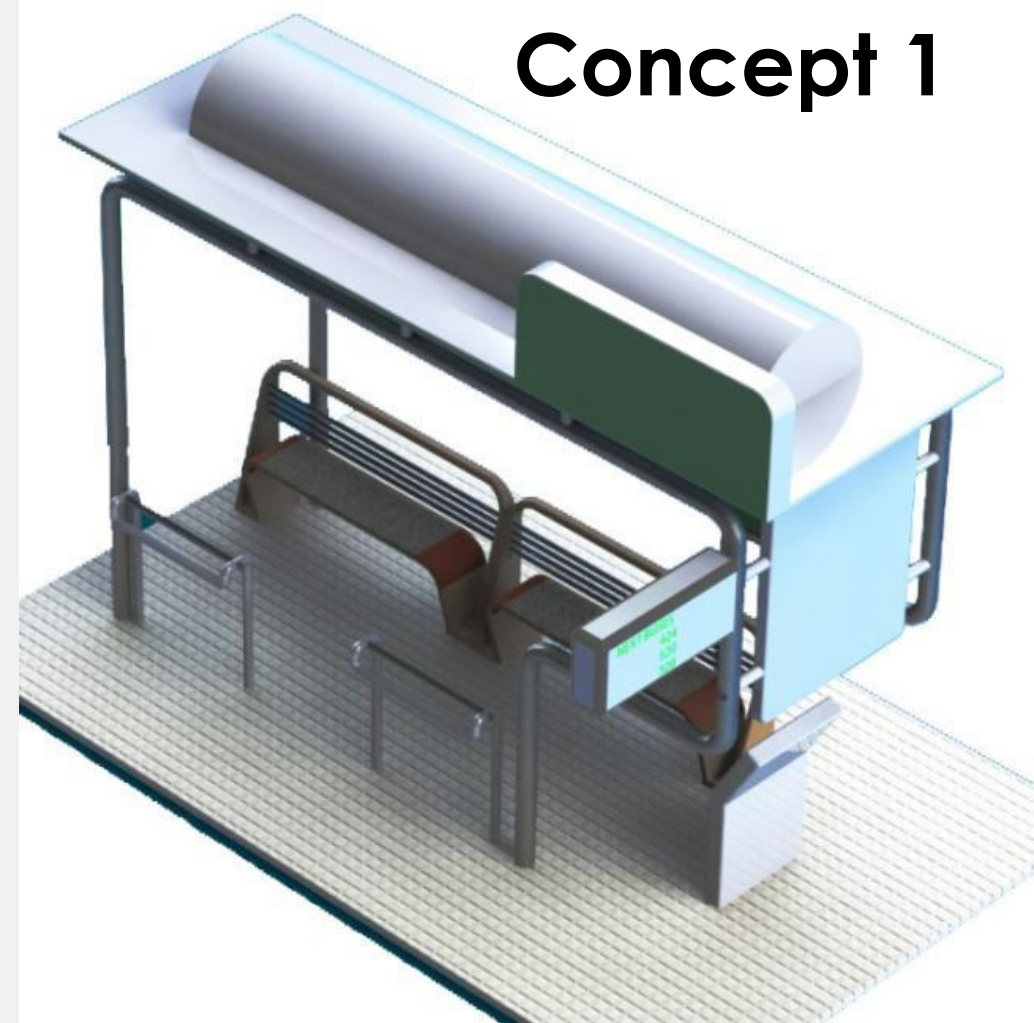

Concept 1

- Organic shape and form
- With digital display and interactive
But
- No enough space for advertisement

Concept 2

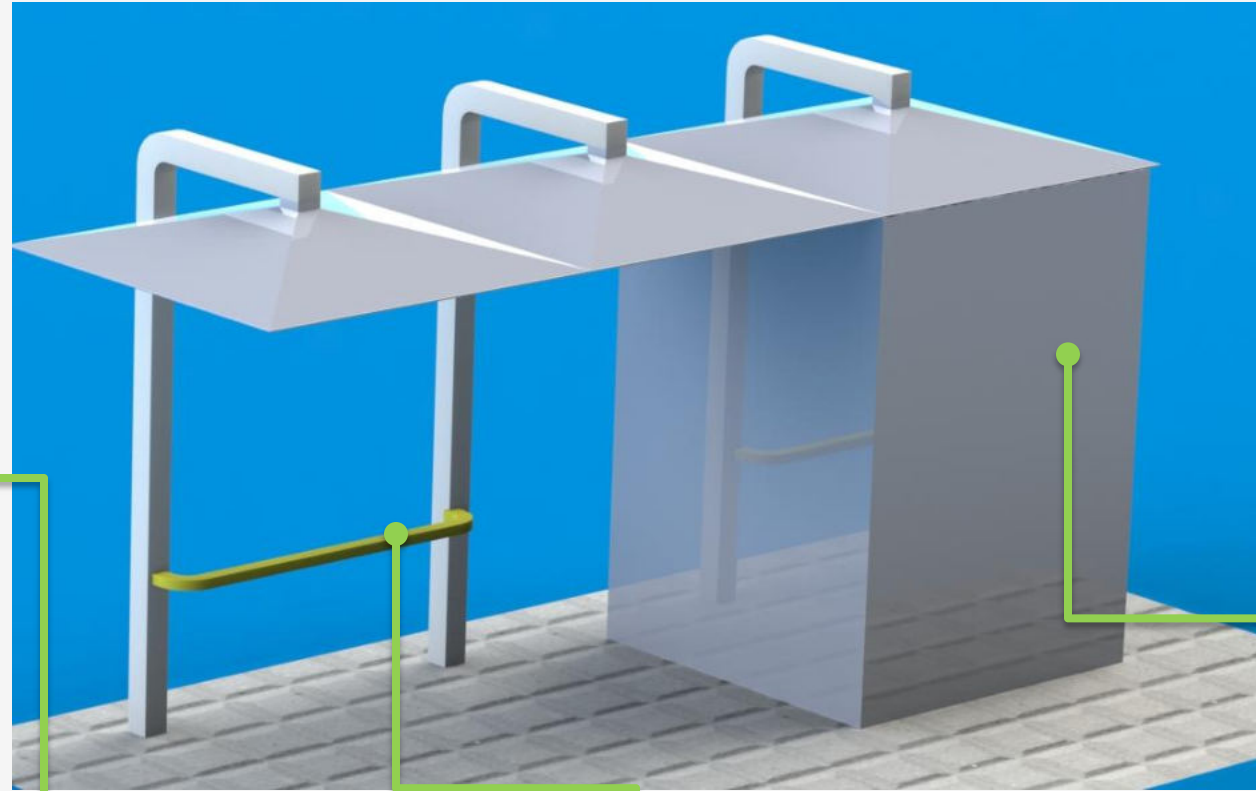
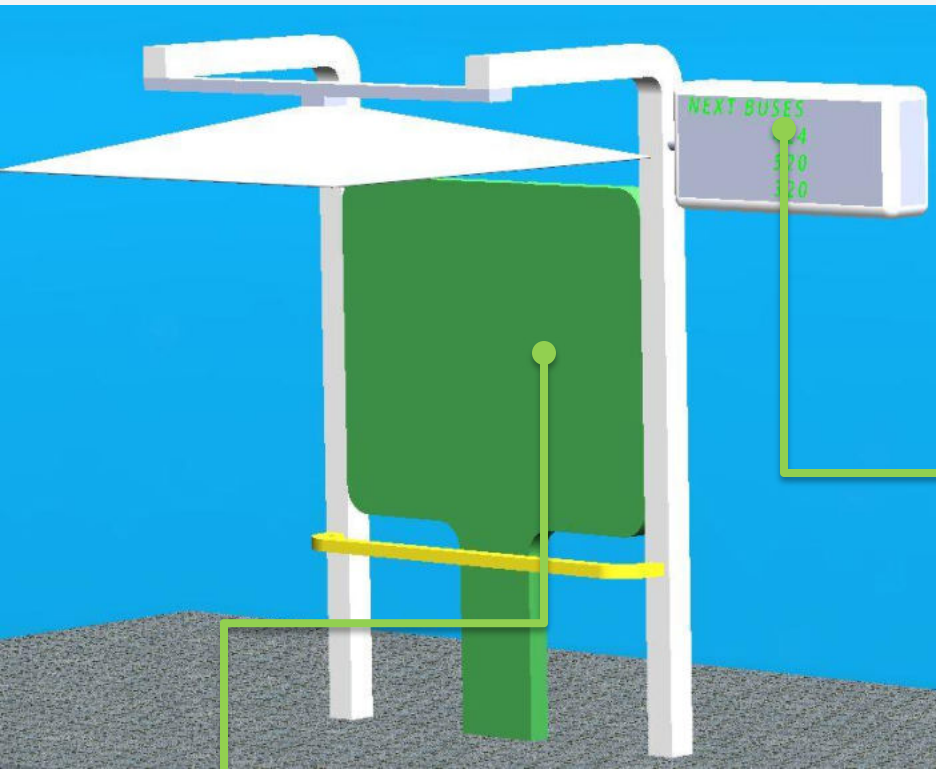

• Place for advertisement

• Digital bus information Board

• Simple Seat bolted to the poles

• Vending kiosk

Rendering

IIT B fence

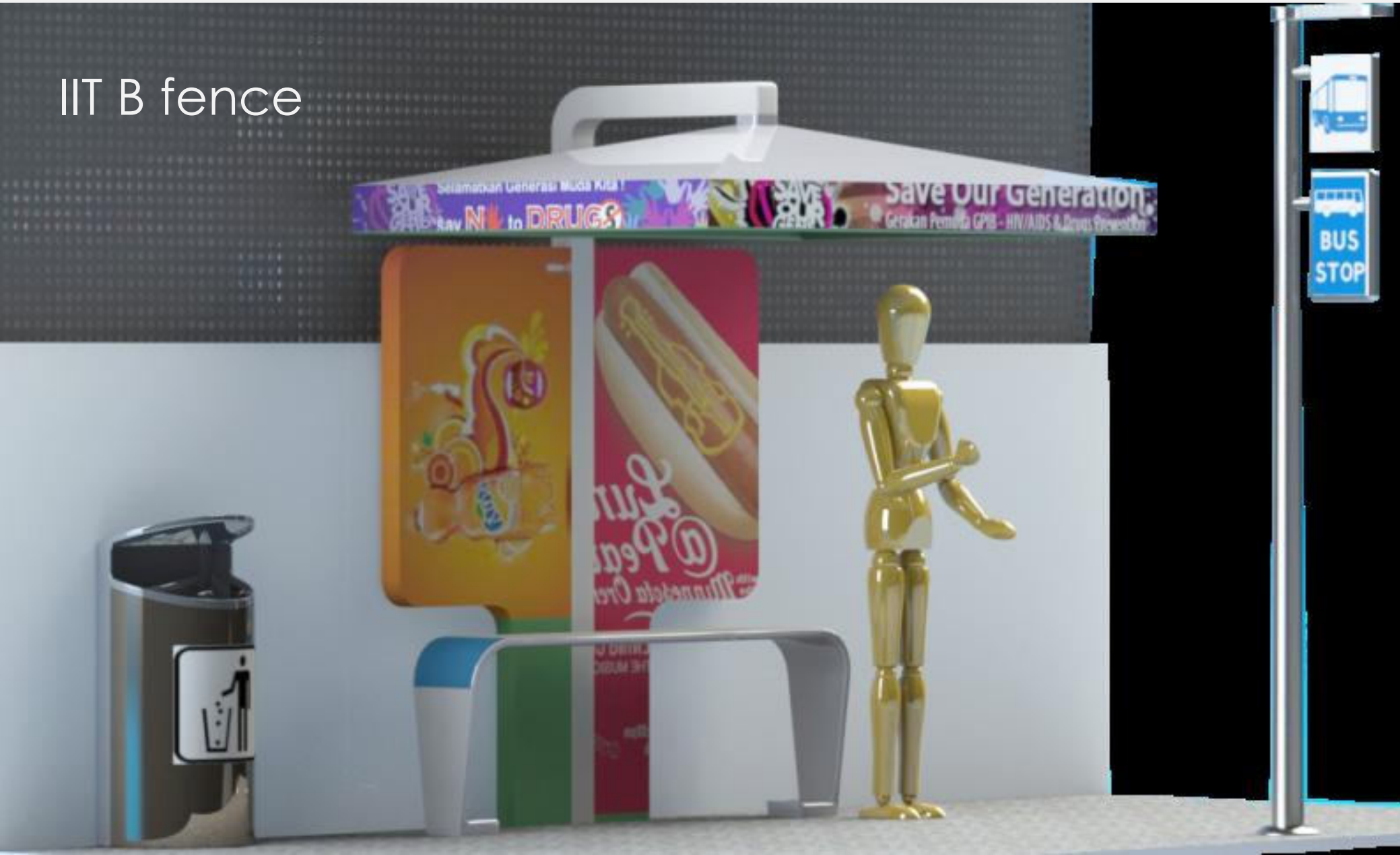

- Simple

- Usable in narrow place like IIT B fence

- Modular

Concept 3

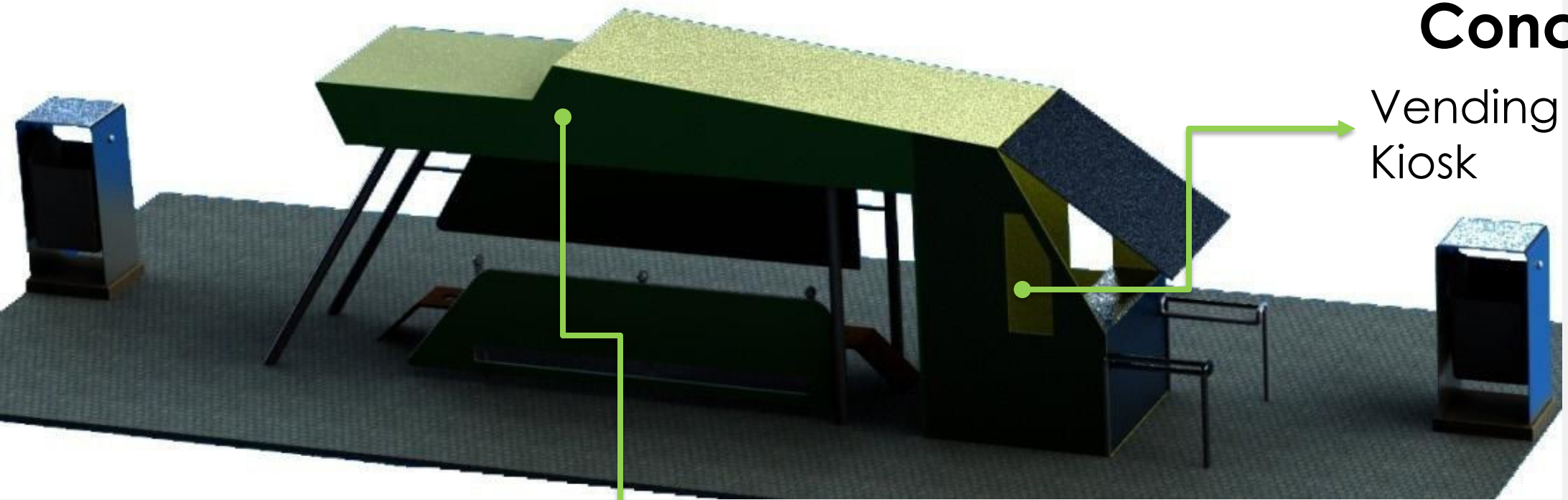

Vending Kiosk

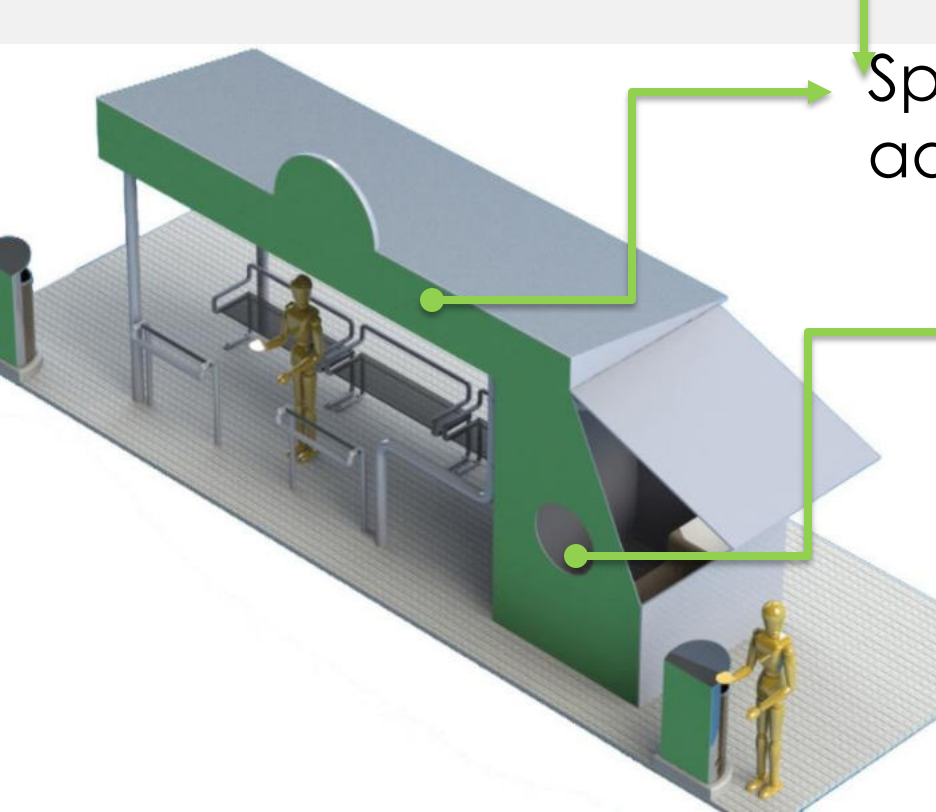

Space for advertisement

Vending Kiosk

- The concept is to mimic bus as a bus stop But looking heavy and massive

- Regular bus stop with Vending kiosk and provided space fro advertisement
- But looking hard and old style

Concept 3

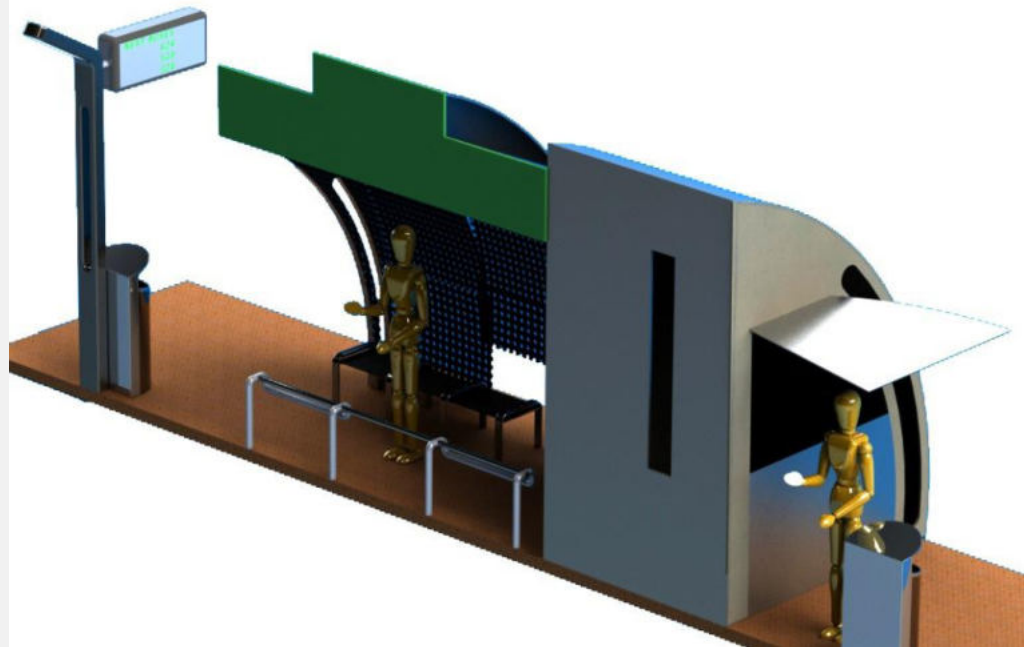

- Modular
- Practical
- Modern

But

- Massive
- No good view to the lake

Rendering

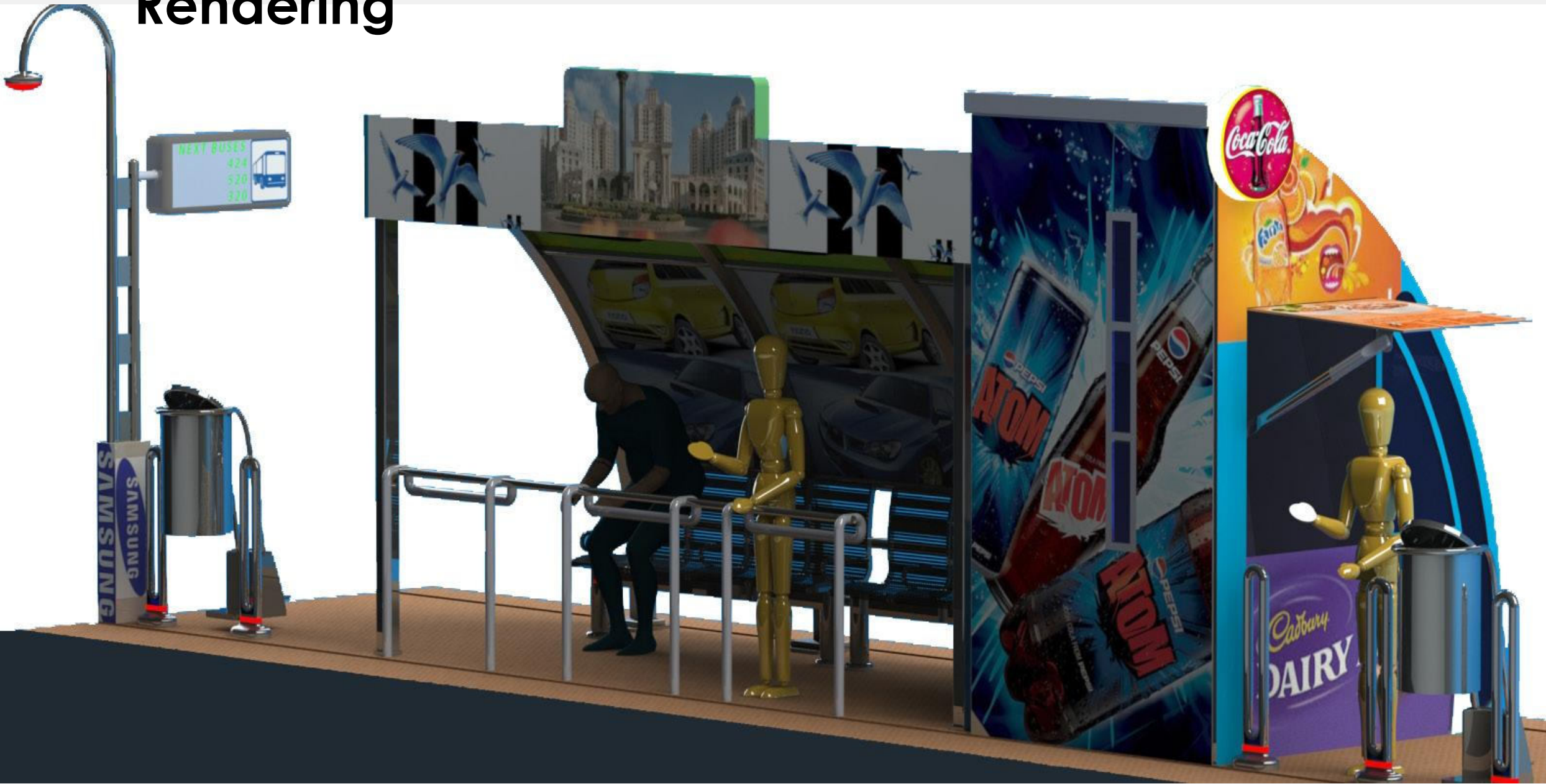

Concept 4

- Modular
- Practical
- Modern
- Simple
- Interactive
- Open
- Allow to view both sides

•Place for digital advertisement

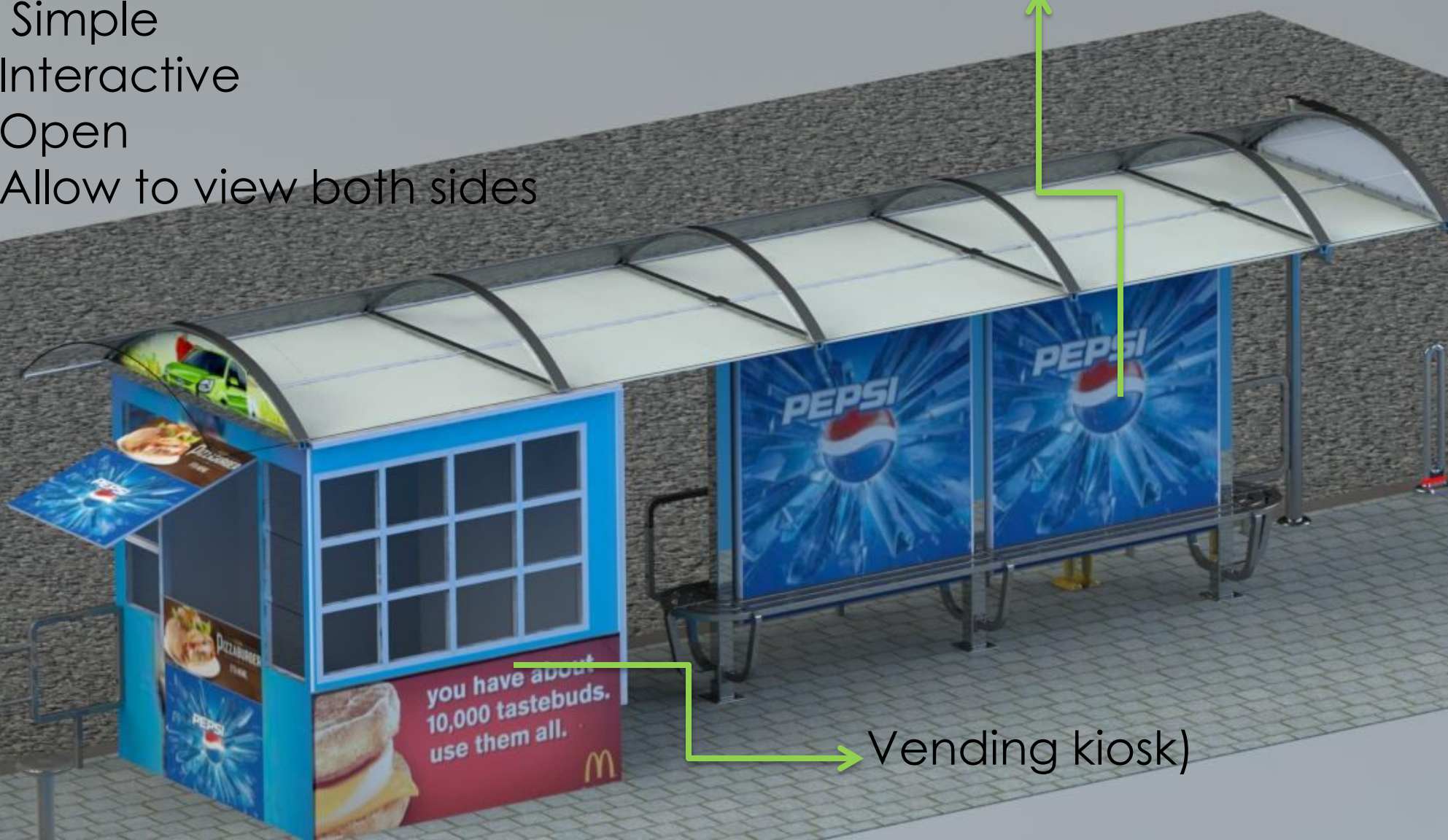

Vending kiosk)

Rendering

140 * 160 cm electronic display with hinged strong glass door for protection

Digital display Bus information Board

120* 160 cm Double Digital display back-lit

Polycarbonate roof cover

Litter bin

Rail, (barrier used to advertize

Bollards



Main road

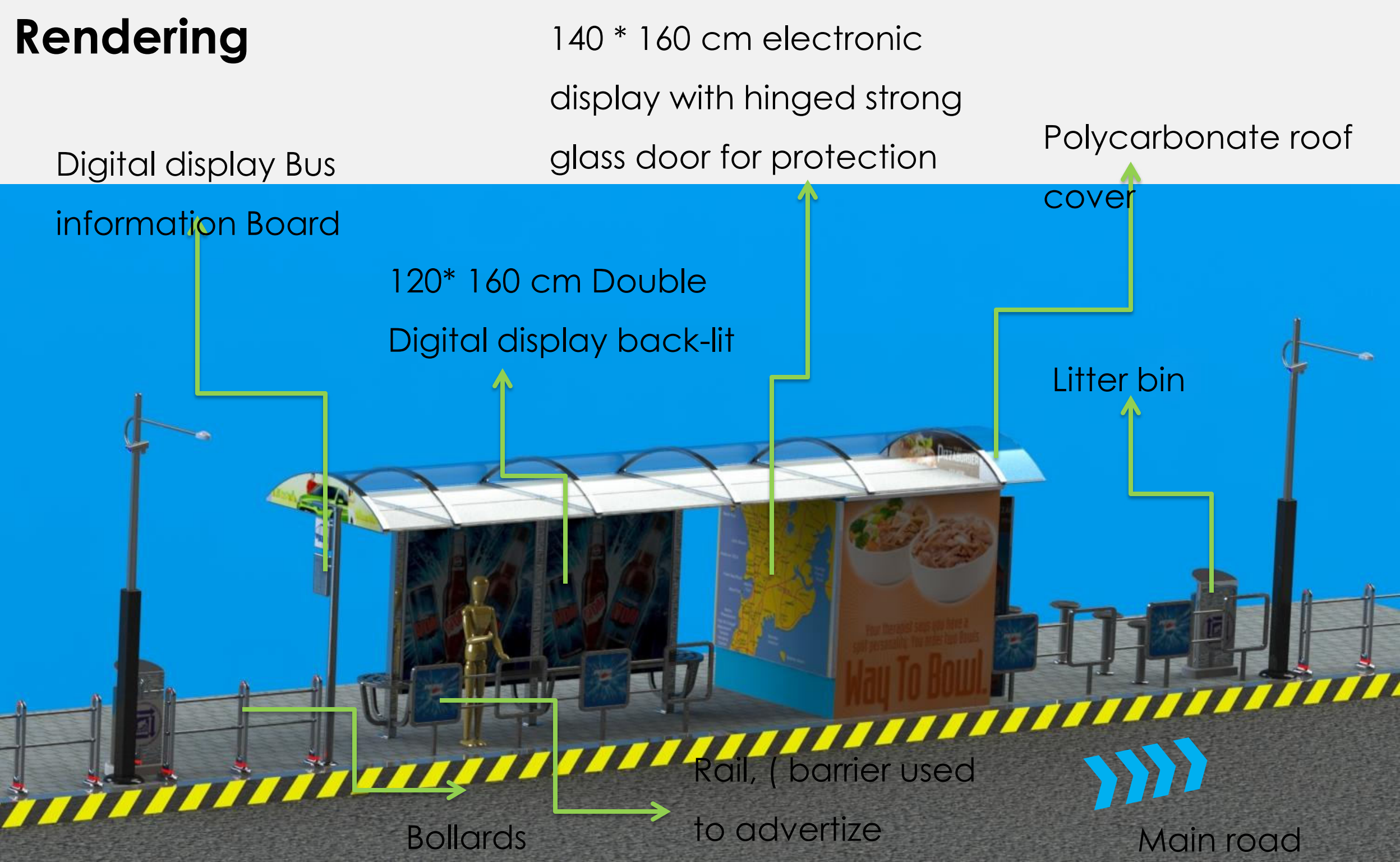

3. Vending kiosk

Concept 1

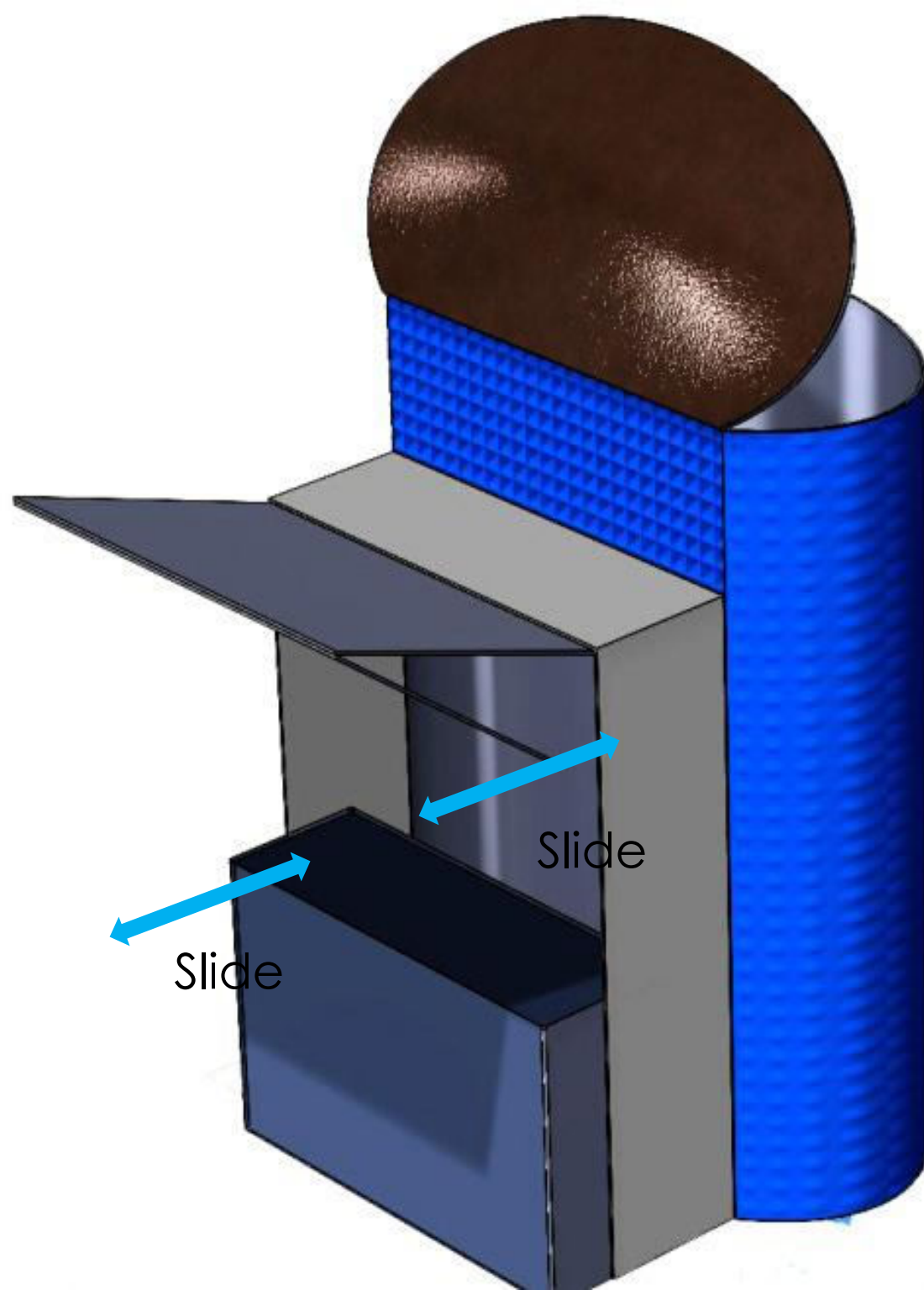

- Modern

- Usable

- Use less space

But

- Different family with the groups

Concept 2

Light pole with
CCTV camera

Extended from bus
stop

Shelf on the
door

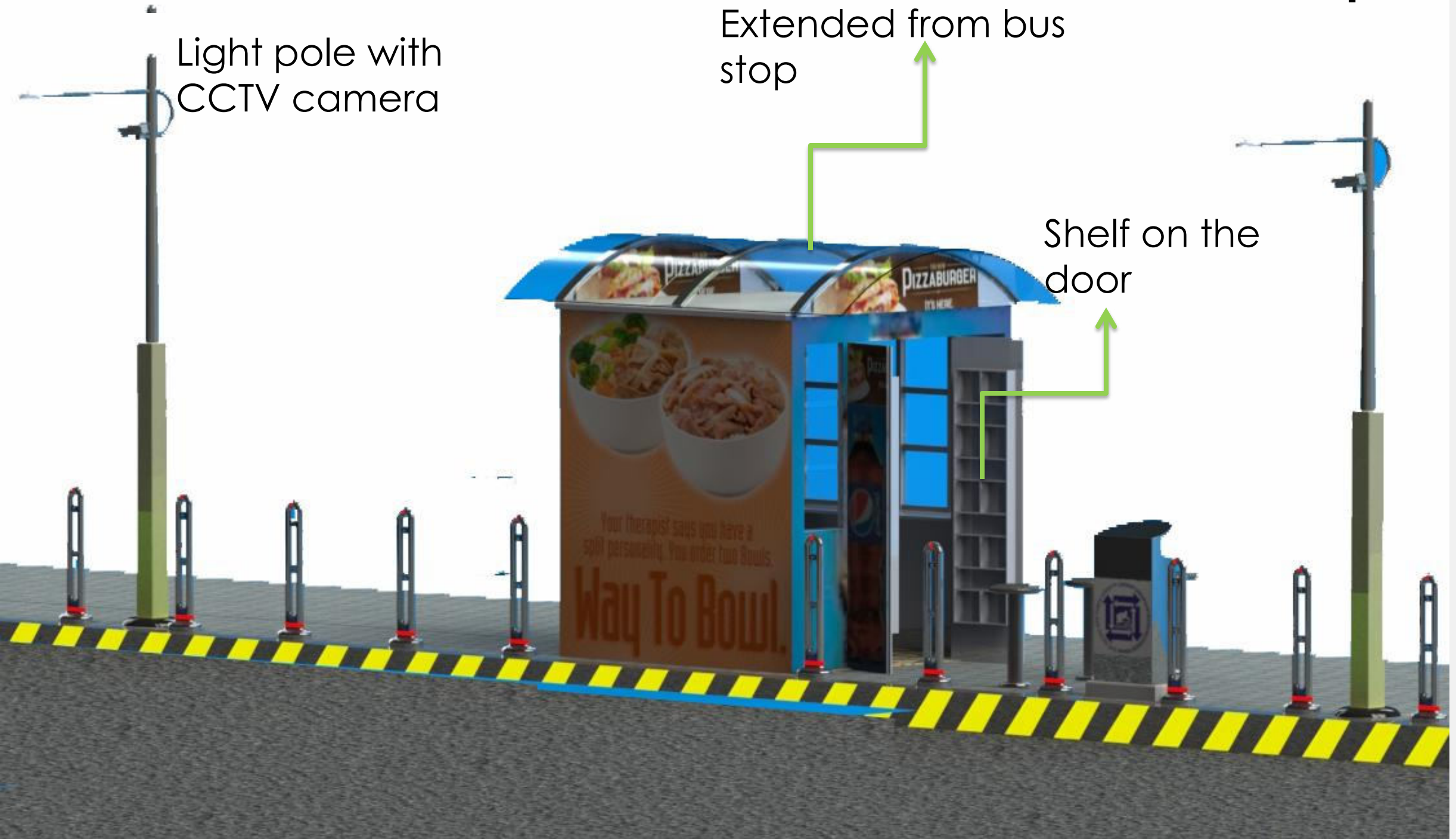

Concept 3

Light pole with CCT camera and place for advertisement

Mumbai Map and information

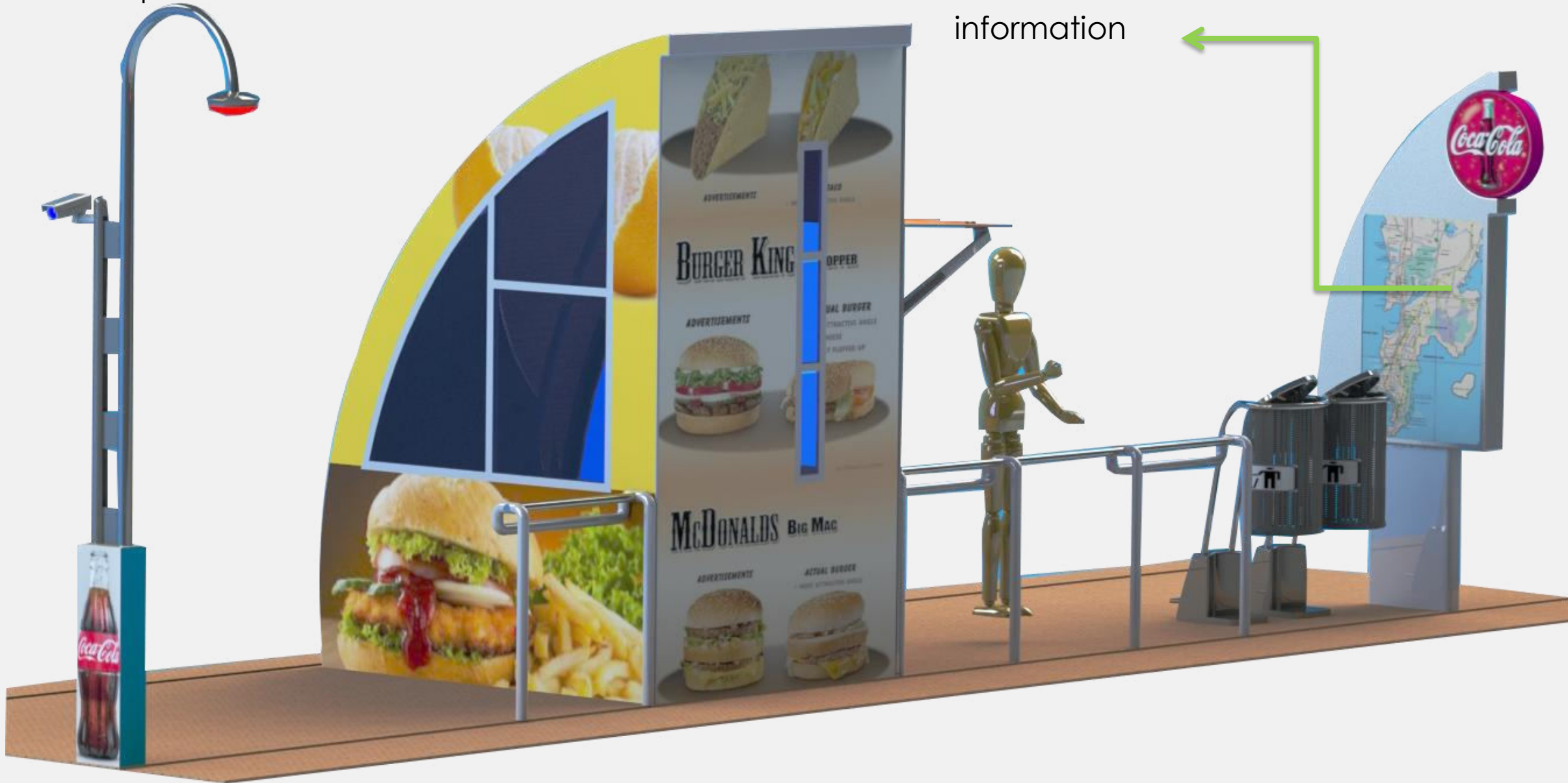

4. Public convenience

- In Public spaces, public convenience may be misused by users because those places are hidden places.
- People may use them for prohibited customs like using drugs, un-social behaviours

Concept 1

- Add some money to open the door
- Door and window should not allow to see inside
- Users would Not see the toilet fixtures directly when the door is opened.

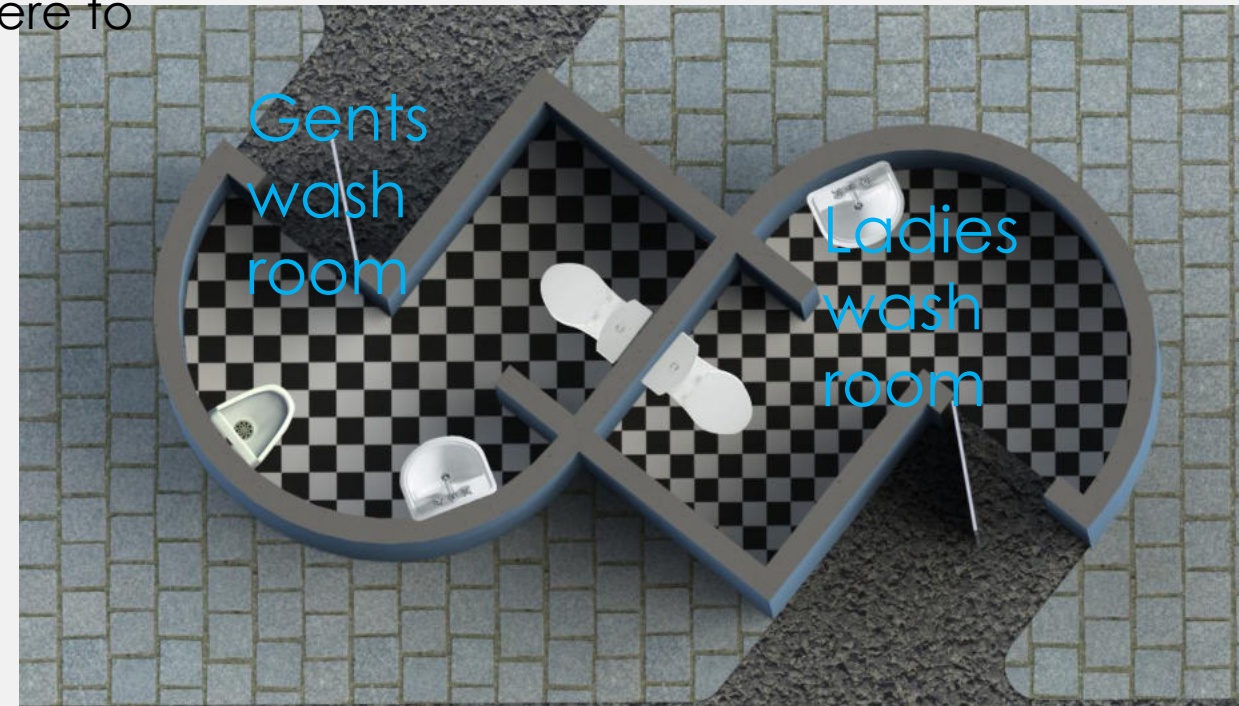

- Interlocking of forms
- Accessible
- Secure

But

- Cleaning issue

Concept 2

It has an office for a person who taking care of the toilet to clean and check every time after people use. This can be a good business generating by take and give mode.

Gents wash room

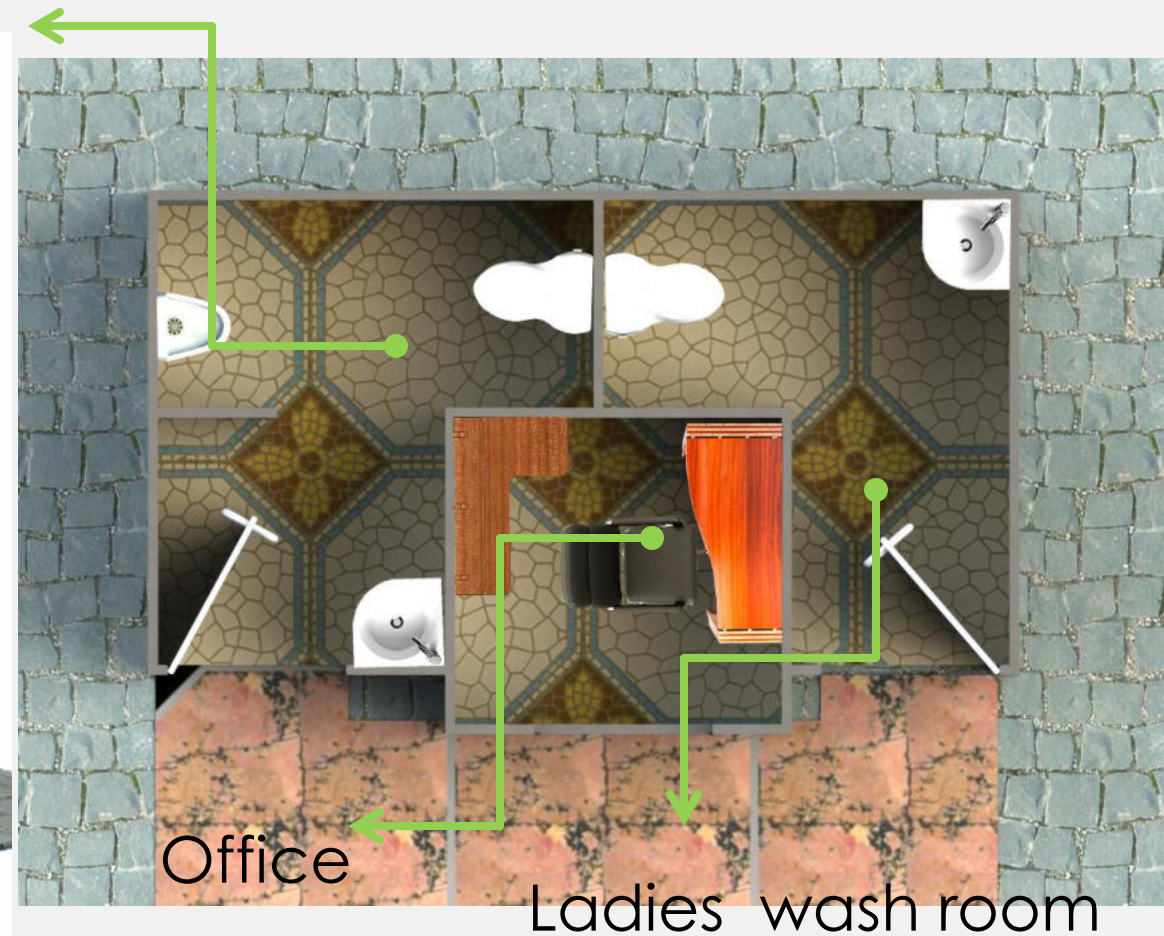
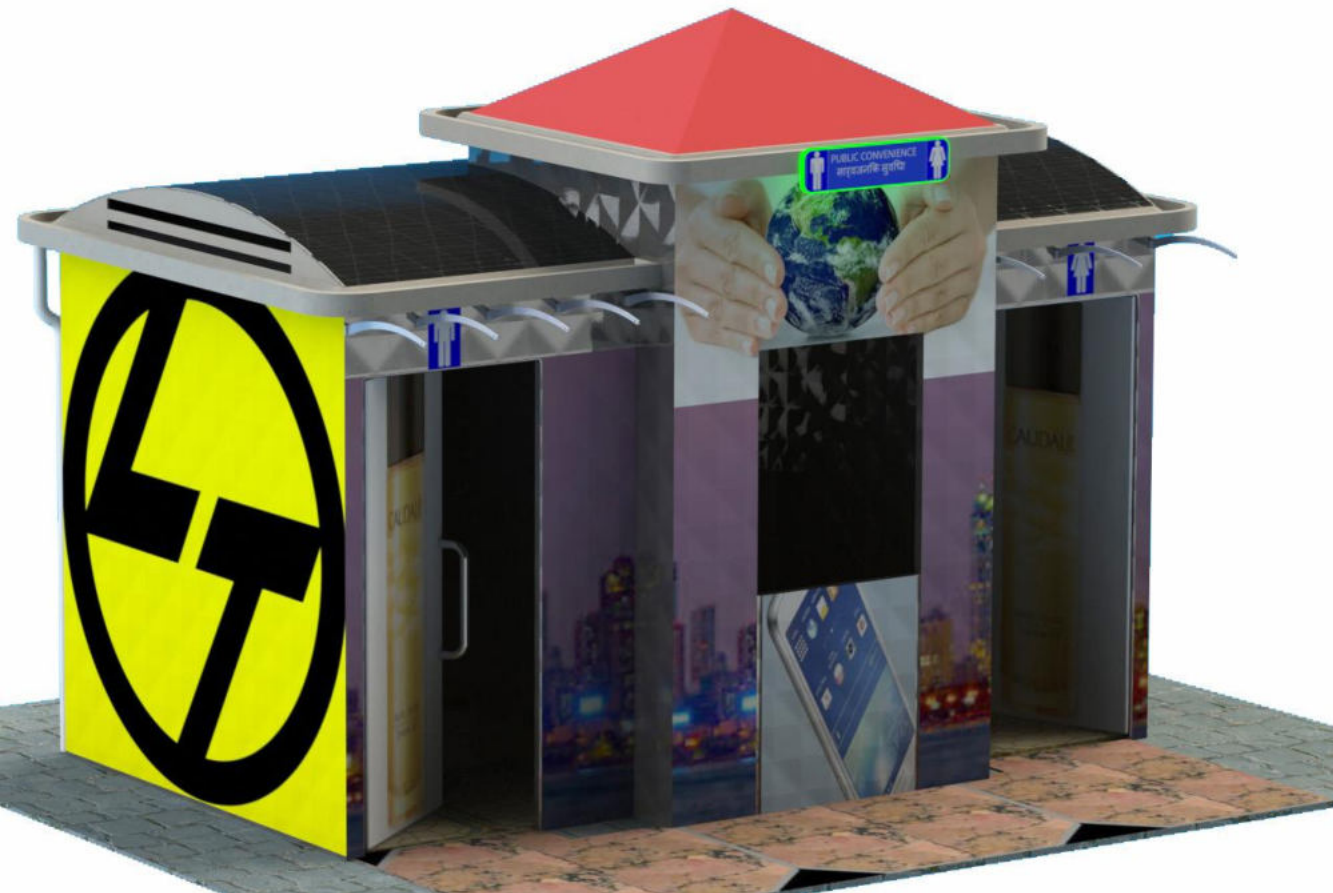

Concept 3



Concept sea shell, Urinal
for men



External urinal with in
ternal WC for both
Female and male

5. Litter bin

Concept 1

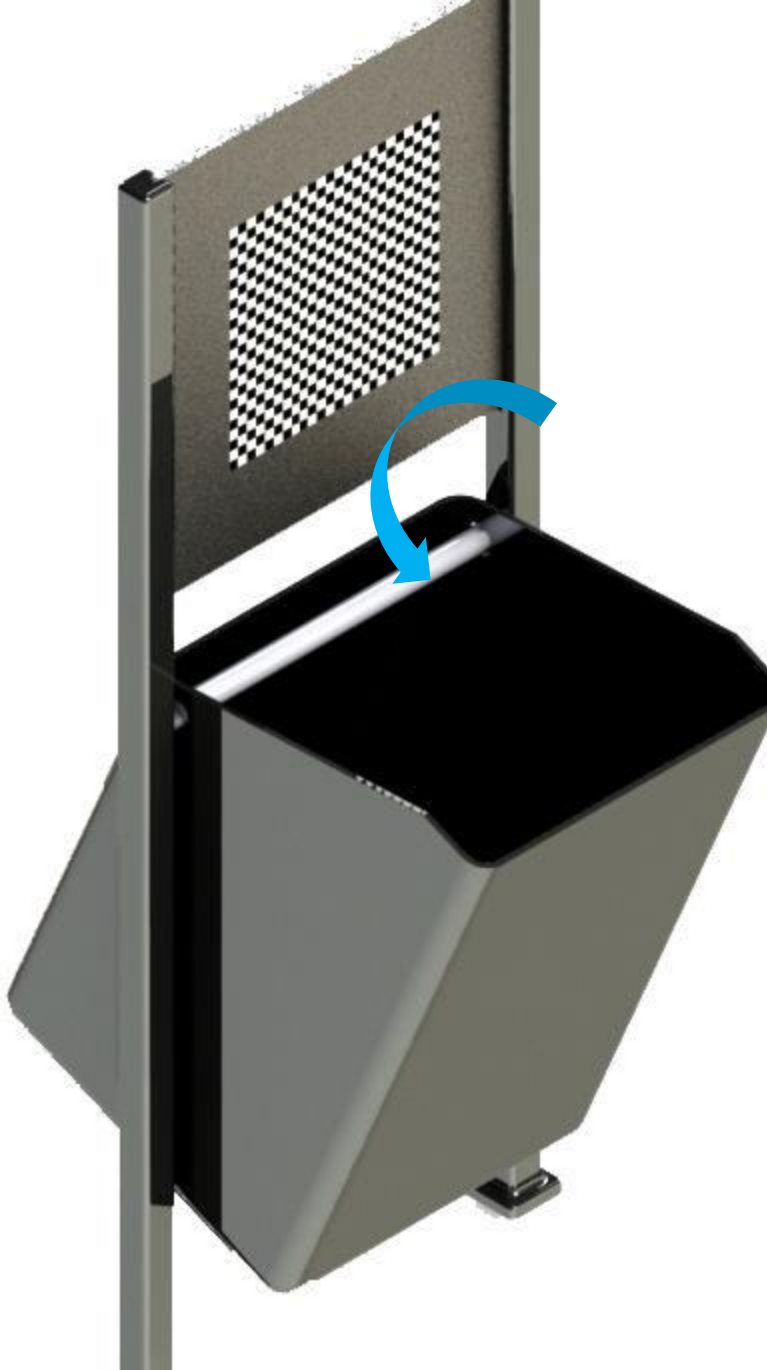

Concept of Basket ball
to throw a garbage in to
the bin as in basket ball
Easy to clean and
playful





Concept 2

The concept is to create simple and easy to clean by turning the body



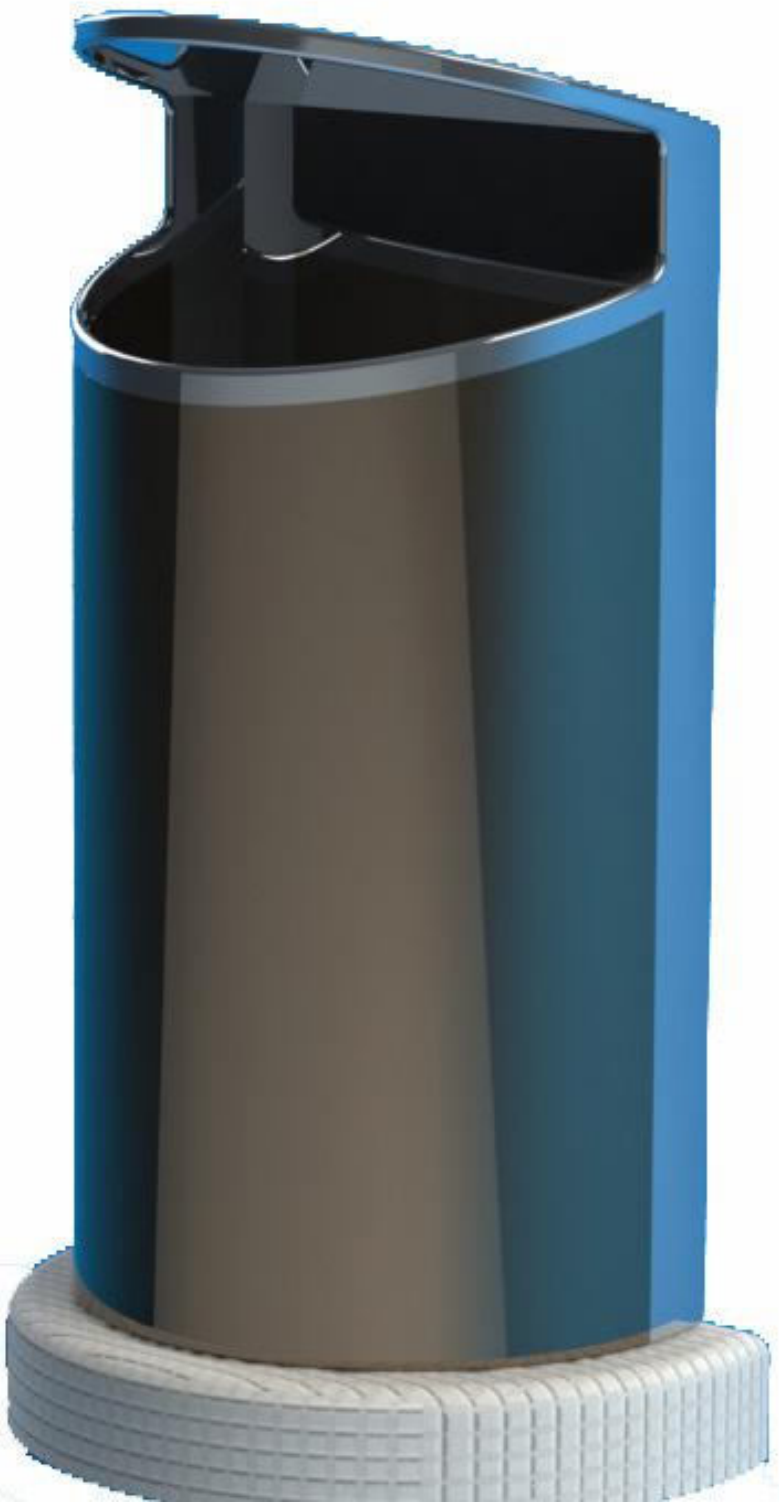

Concept 3

- Elegant
- Simple, usable
- Easy to clean(Open and takeout the container inside)
- Durable
- Invite to use

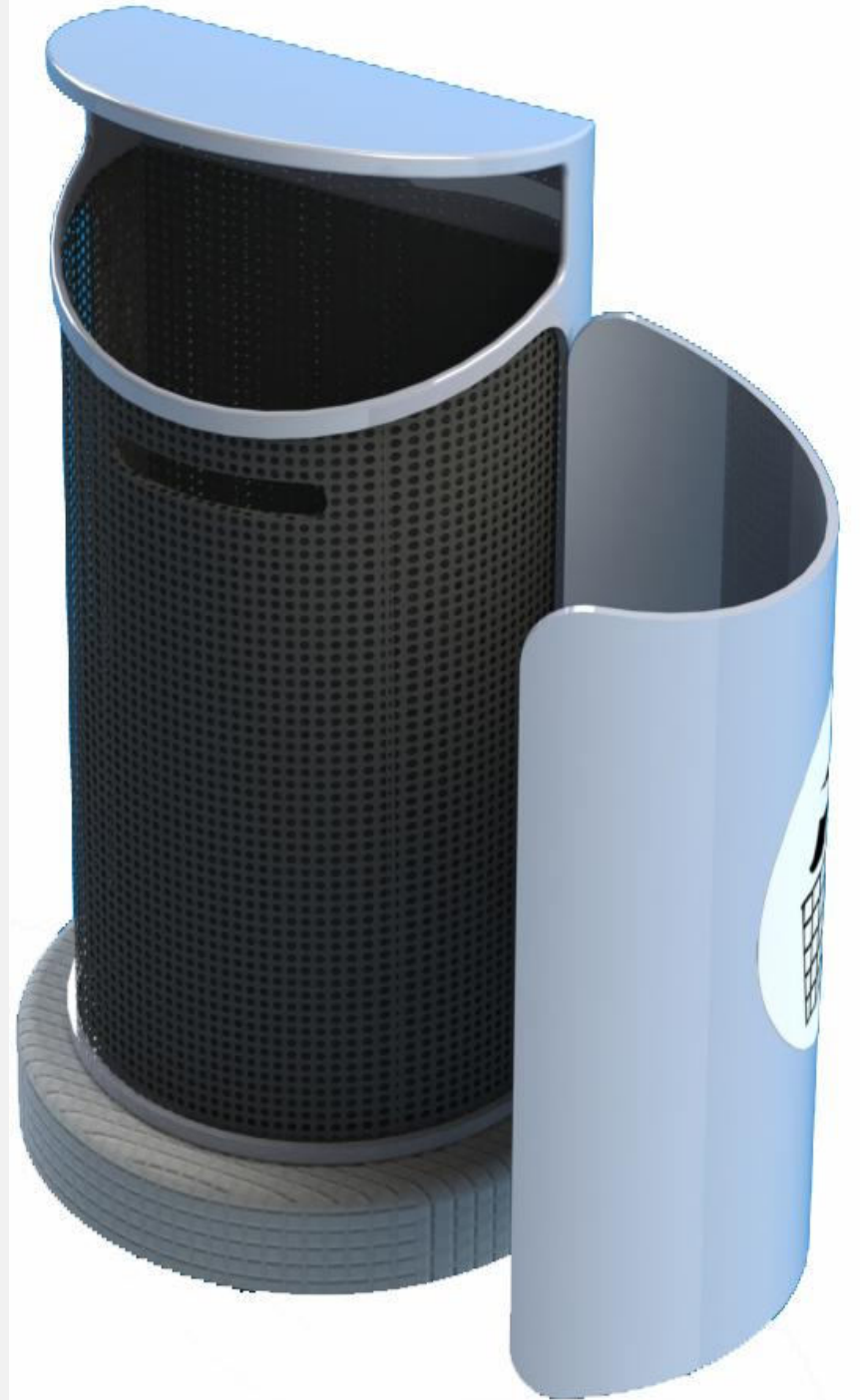

Concept 4

- Elegant
- Simple, usable
- Easy to clean
- Durable
- Invite to use



Concept 5

- Elegant
- Simple, usable
- Easy to clean
- Durable
- Invite to use

- To step on foot to open the cover



6. Lighting



- LED lighting with CCTV camera
- Space for advertisement



- Lighting pole with solar panel

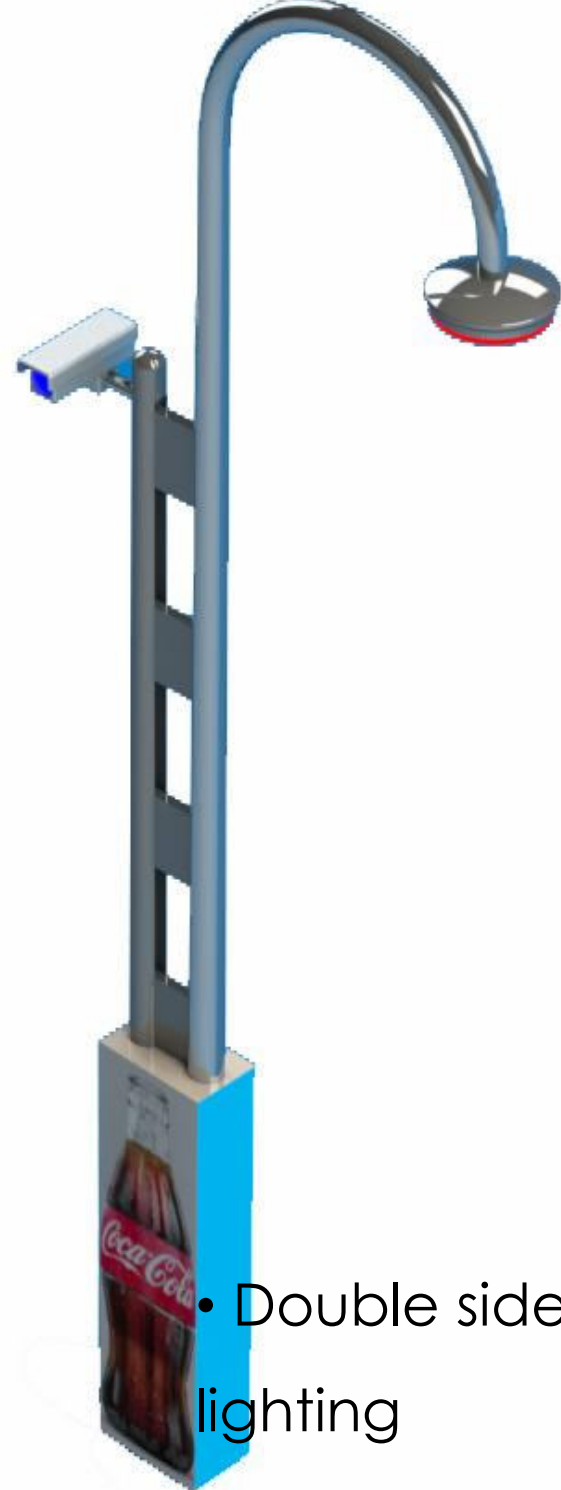

- Double sided lighting



- Lighting for around lake side

7. Bollards



- Simple
- Elegant
- Usable
- Practical

Not for public space



- Simple
- Elegant
- Usable
- Practical
- Stronger
- Can fit in the family

- Simple
- Elegant
- Usable
- practical

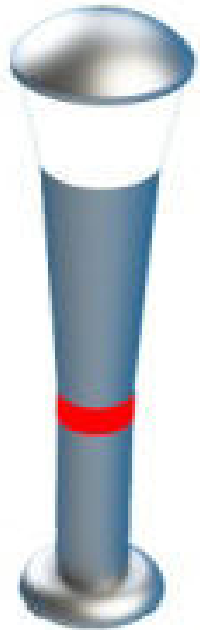

- Simple
- Elegant
- Usable
- Practical

Looking lighting for lake side

- Simple
- Elegant
- Usable
- Practical
- Space for company name



8. Information Boards



Information for bus directions at elevated



Serve as a bollard and directions for bus



Electronic display and reflected light in the bottom portion

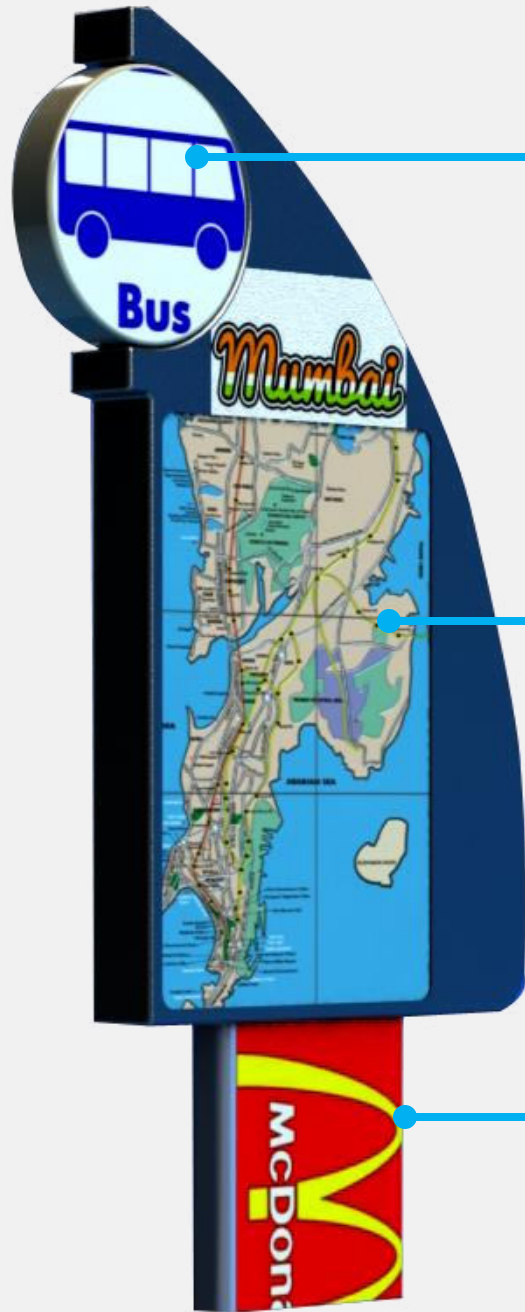







Space for advertisement





Display area of 1060 * 710 mm Double side backlit information panel with hinged temporary glass door provided with gas struts

Galvanized steel stand grouted to concrete base through anchor bolts

Concept evaluation

No	Bus Queue shelter	Sturdy	Modern and simple	More open to view	Iconic and memorable	Friendly and approachable	Enough space for advertisement
1		Yes	Yes	Yes	Yes	Yes	No
2		Yes	Yes	Yes	Yes	Yes	Yes
3		Yes	Yes	No	Yes	Yes	Yes
No	Litter Bin	Easy to clean	Elegant	Durable	Simplistic	Approachable	Practical
1		Yes	Yes	Yes	Yes	Yes	Yes
2		Yes/2	Yes	Yes/2	Yes/2	Yes	Yes
No	Public convenience Types		Usable	Clean and safe		Practical	Approachable
1			Yes	Yes		Yes	Yes
2			Yes	Yes/2		Yes	Yes

Benches		Simple, Sturdy	Durable and practical	Usable	Family looking
1		Yes	Yes	Yes	Yes
2		Yes	Yes	Yes	No
Bollards		Modern	Unique	Strong	Durable
1		Yes	Yes	Yes	Yes
2		Yes	Yes	Yes	Yes/2
Light pole		Modern	Unique	Strong	Durable
1		Yes	Yes	Yes	Yes
2		Yes	Yes	Yes	Yes/2
3		Yes	Yes/2	Yes	Yes

Vending Kiosk		Modular, simplistic and modern	Sturdy and family looking	Easy to access and erect	Environmental friendly
1		Yes	Yes	Yes/2	Yes
2		Yes	Yes	Yes	Yes
3		Yes	Yes	Yes/2	Yes
Information Board		Readability	Family looking	Modern	Usable
1		Yes	No	No	Yes
2		Yes	Yes	Yes	Yes

Selected concepts to group

SKYLINE 1

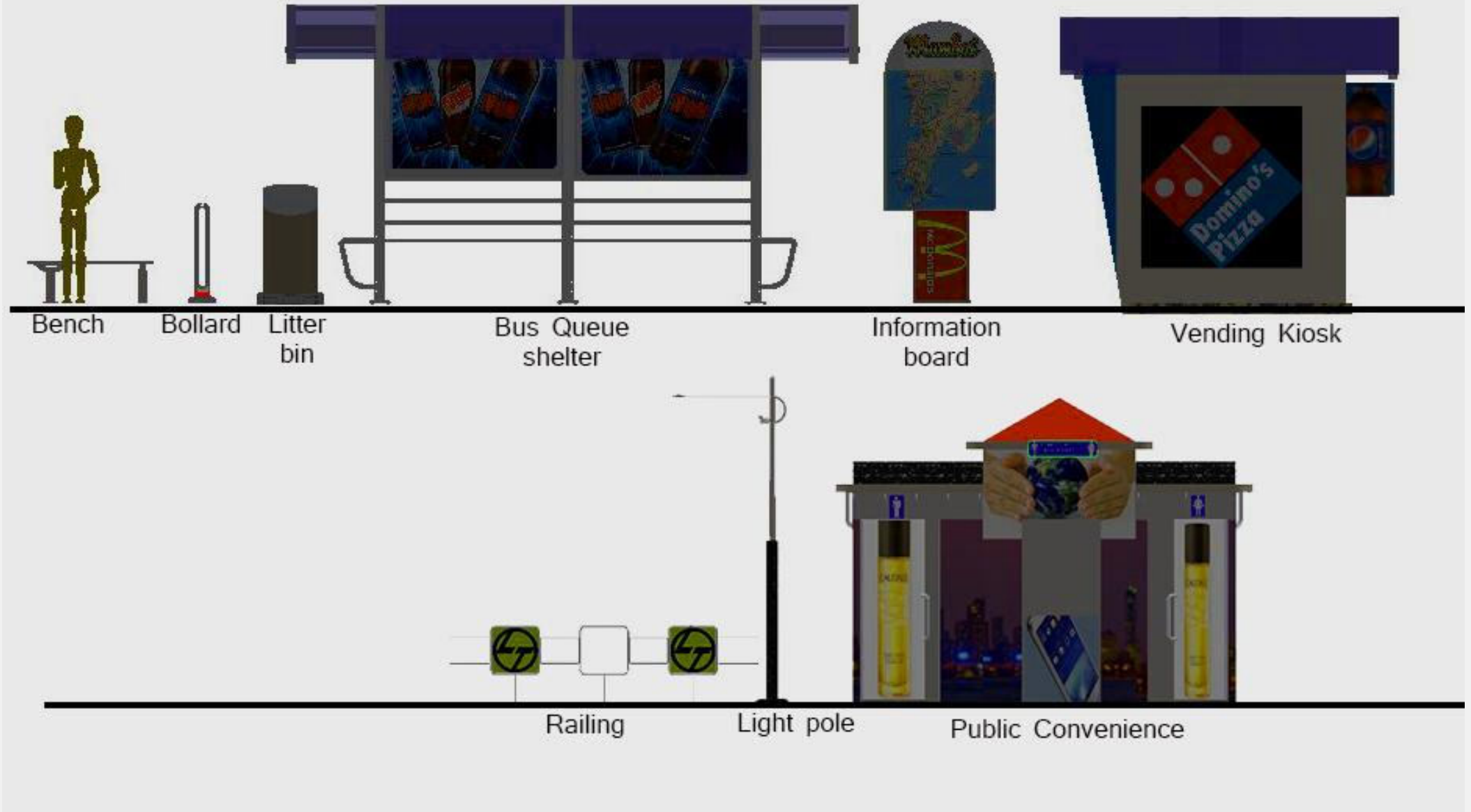



Information Board



Vending Kiosk



Bus stop



Sun Shade

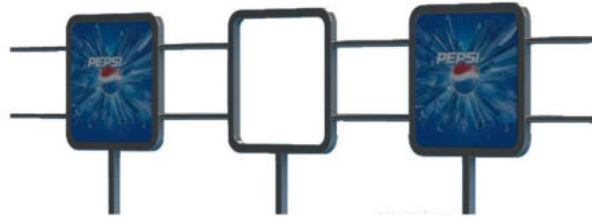

Railing in bus stop and in the street

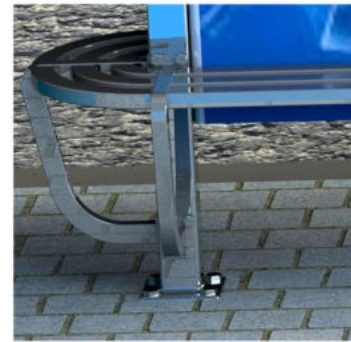

Bench and Bus stop seat with similar material and look



CCTV Camera with light pole



Public Convenience



Litter Bin



Bollards

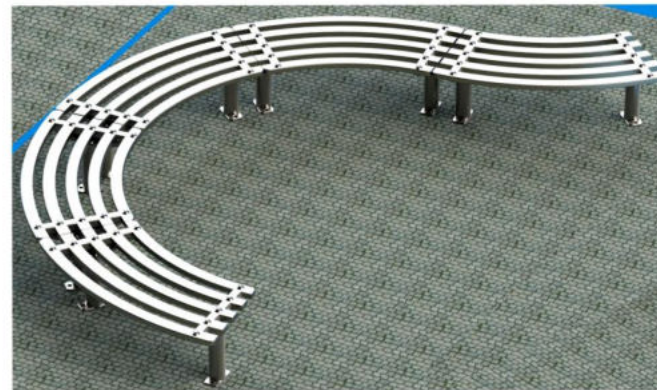

Bench that can be arranged in different arrangements

Light Pole

SKYLINE 2

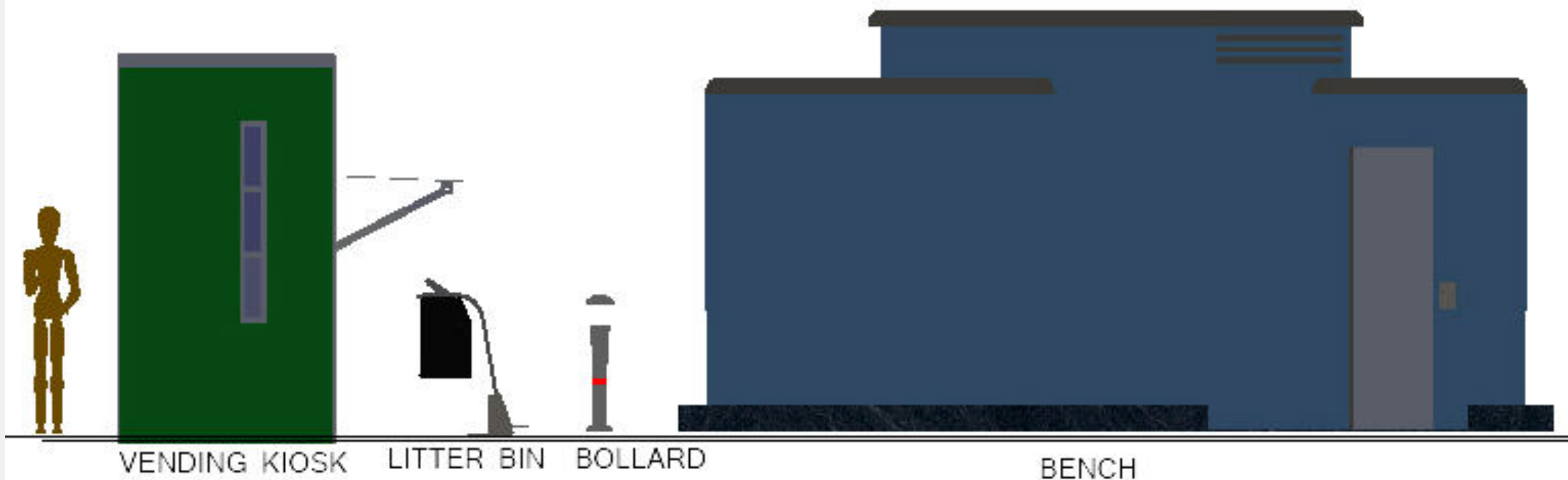

Light pole

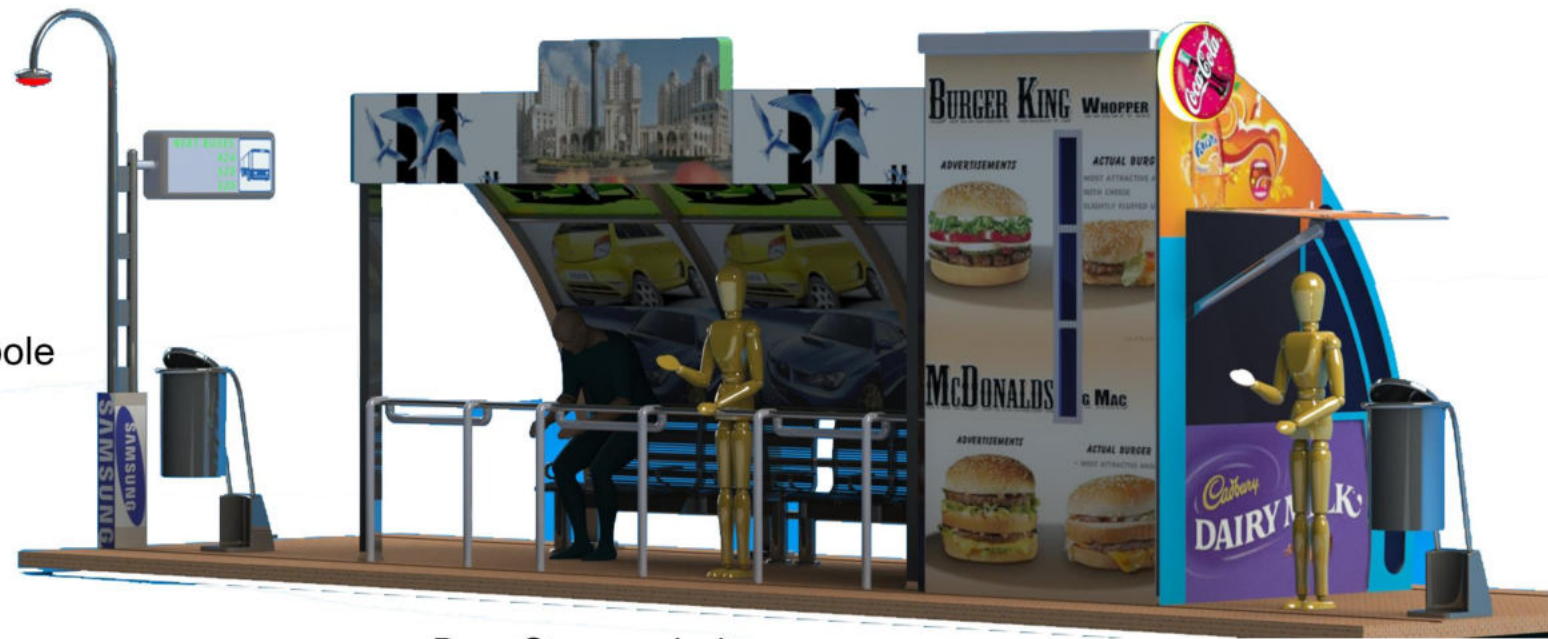

Bus Queue shelter



Bench



information board



Public convenience



Litter bin



Bollard

SKYLINE 3

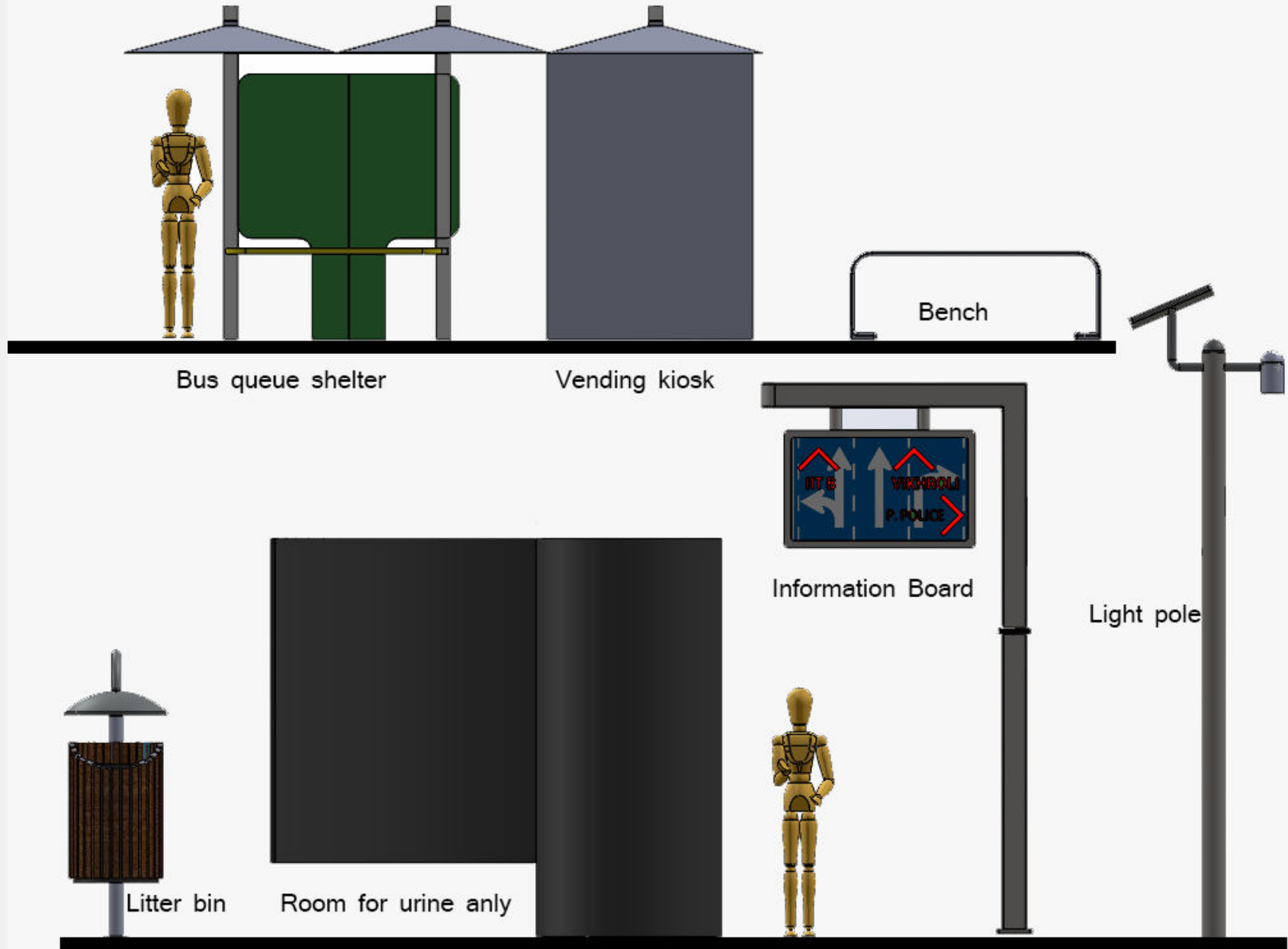

SKYLINE 3



BUS QUEUE SHELTER



BOLLARD



INFORMATION BOARD



LIGHT POLE

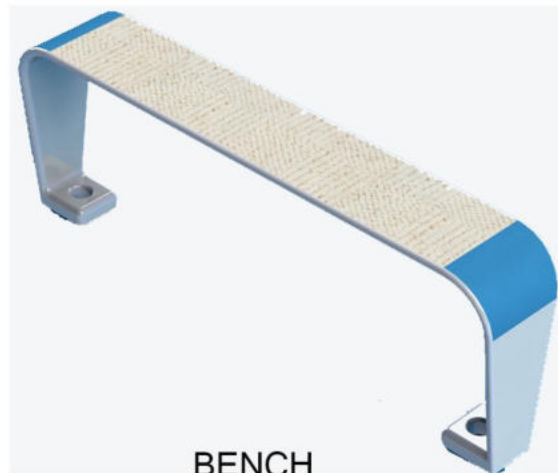

BENCH



LITTER BIN

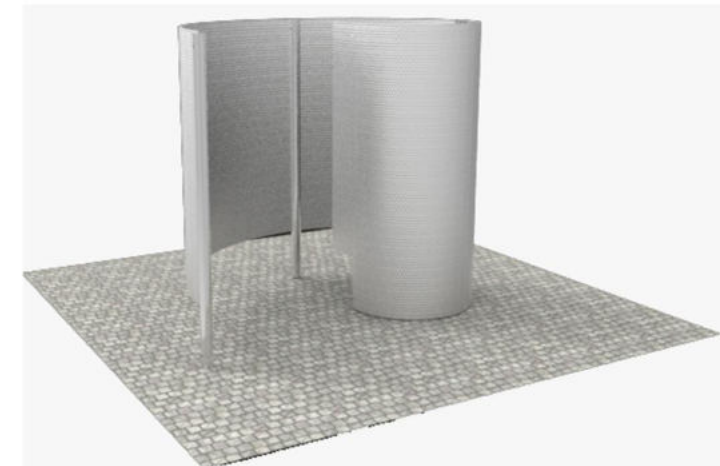

TOILET FOR URINE ONLY

Evaluation of family products

Selection criteria	Skyline 1	Skyline 2	Skyline 3
Family looking	Yes	Yes	Yes/2
Simplistic	Yes	Yes/2	Yes
Easy to maintain and erect(modular nature)	Yes	Yes/2	Yes
Usability and practical	Yes	Yes	Yes
More open space for users	Yes	Yes/2	Yes
Modernity	Yes	Yes	Yes/2
More space for advertisement	Yes	Yes/2	No
Approachable and interactive	Yes	Yes	Yes
Minimum use of space in actual construction(site)	Yes	Yes/2	Yes

According to the selection criteria given in table 4, skyline 1 (family 1) got more yeses. So, the products in skyline 1 are the final products to be installed in Powai lake face road. After this the bus and the vending kiosk in skyline 1 will be detailed, modelled, and rendered as a final out put. The rest of the products from skyline 1 (final products) are listed below with their dimensions and views for the future installation.

Possible Materials

- Products used near the lakes and seaside can maintain durability and weather resistance by applying a special layer coating done on steel structure called 'seaside treatment'.
- Ionized aluminum panel, suitable for application involving exposure to lakeside environments.
- Galvanized steel in internal frames, LED lighting for durability and power - saving and eco- friendly.

- All metal furniture and parts would be **Powder coated with polyester powder** with UV stabilized colors
- Vitreous enameling and steel treatment mostly used in military equipments
- Natural or processed wood (mixed with fiber and premium hard wood, Iroko, oak, etc.)
- 'Iroko' is suitable for weather resistance and durability.

- Fiber glass(FRP)
- Precast concrete
- Metal products either polished or powder coated
- Polyurethane(PU) Elastomer and Polyethylene(PE) is also suitable for street furniture.
- Copper alloys (20%) can also be used due to its anti-microbial property

Selected material

- Stainless steel is selected because of the following properties
- Rust and other forms of corrosion and has an attractive appearance.
- It has a unique self-healing property due to the alloying elements used, a thin, transparent layer is formed on the surface.
- It does not require any coating or other corrosion protection to remain bright and shiny even after decades of use.
- In case the surface is scratched or damaged otherwise, this thin layer, which is only a few atoms thick, immediately rebuilds with the assistance of oxygen from air or water

No	Furniture name	Final selected materials
1	Bench	stainless steel grouted to a concrete base
2	Bus queue shelter	All parts are stainless steel and columns are grouted to a concrete base for vandalism Roof cover: polycarbonate
3	Vending kiosk	Double layer stainless steel and thermo Cole in between the layers for heat resistance and sound proof
4	Litter bin	stainless steel external body and perforated steel in side to collect the garbage
5	Public convenience	Double layer stainless steel thermo Cole in inside in between for heat resistance and sound proof
6	Light pole	stainless steel grouted to a concrete base
7	Bollard	stainless steel grouted to a concrete base
8	Information Boards	stainless steel grouted to a concrete base and electronic display

Manufacturing

- Strong materials
- Rest proof (stainless steel)
- Pre fabricated materials which can assembled on the site.

Maintenance

- All the public amenities on the street should need maintained regularly at public expenses.
 - Earlier furniture was erected by BEST (Bombay Electric Supply and Transportation)
 - Current furniture are donated/sponsored companies to run the hidden agenda 'Advertisement'
 - Self financed at zero cost to the city by advertizing
-
- ❖ Based on the experience of MMRDA, sponsoring companies (L&T and Hiranandani) are interested to erect based on '**built and operate system**' by giving limited advertizing rights.

Final concepts 2D drawing

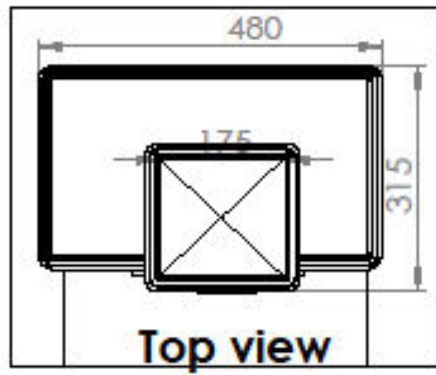

Public
convenience

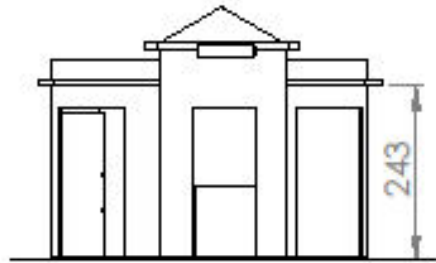

Front view

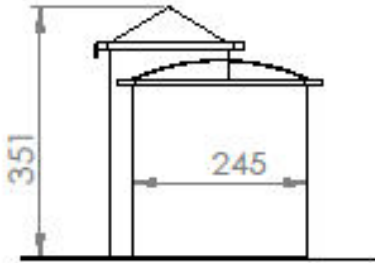

Side view

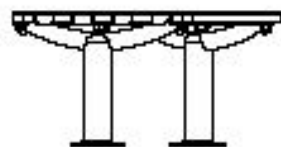
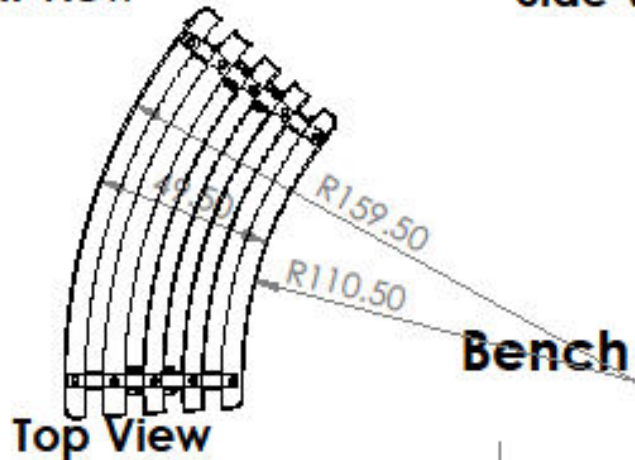

side view

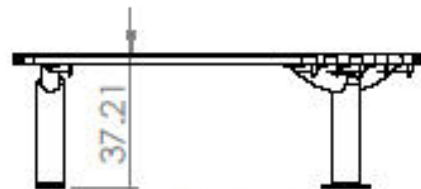

Front view

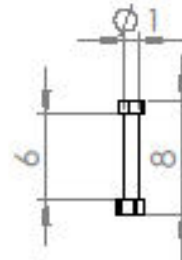
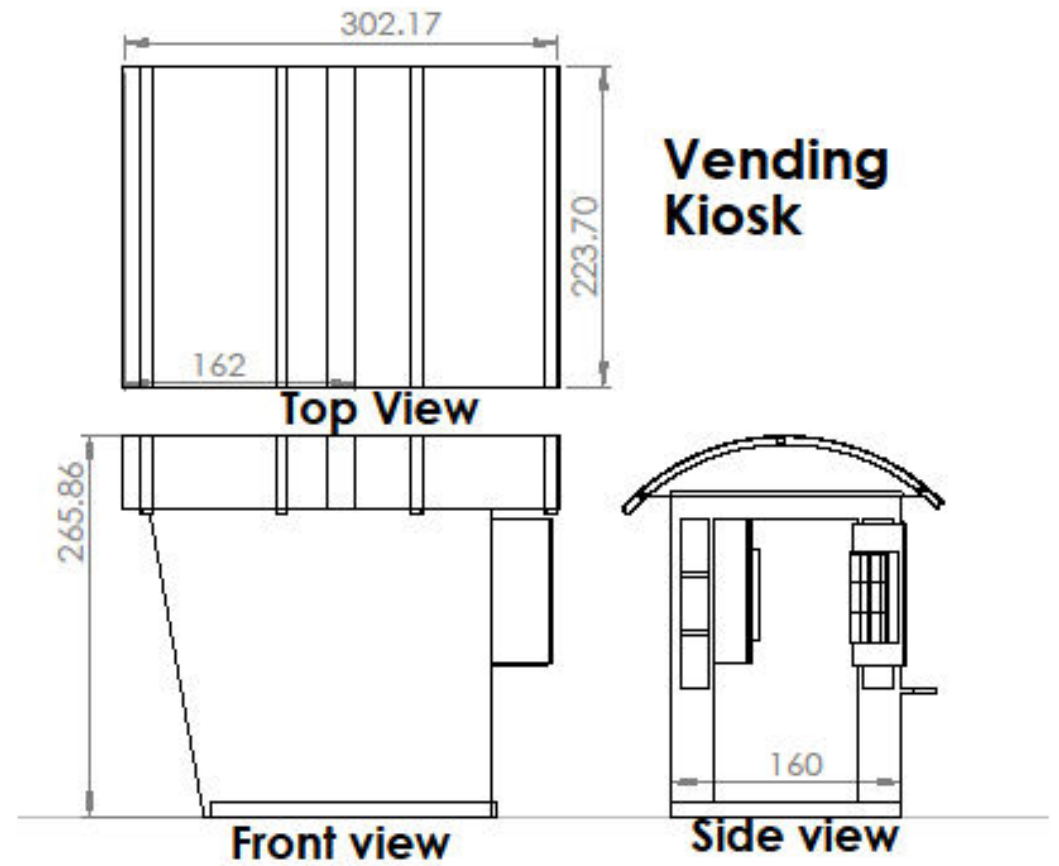

2D drawings of Public
convenience, Vending
kiosk and bench with bolt
to fix the products with
concrete block

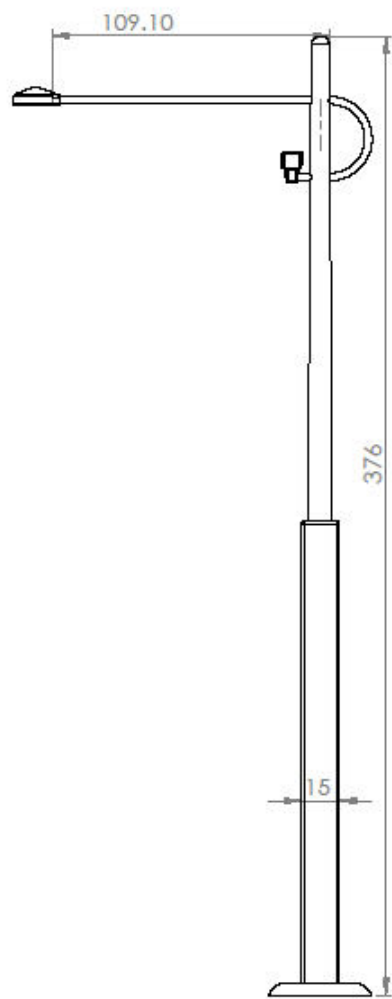

Light pole

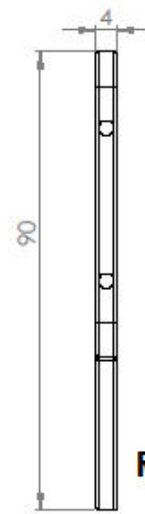
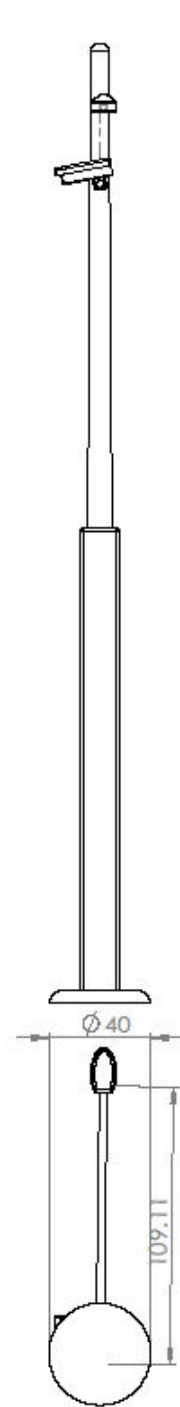

Rail in bus stop

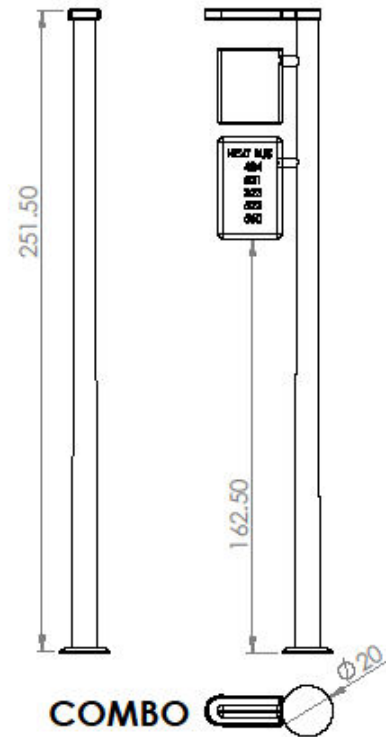
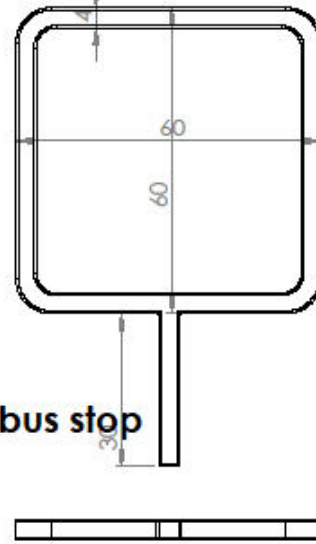

COMBO

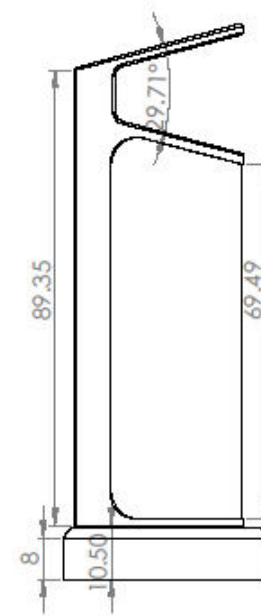

Litter bin

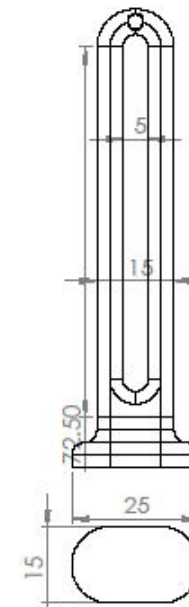
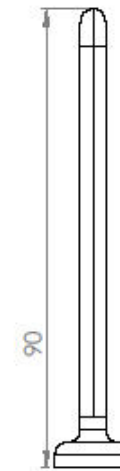
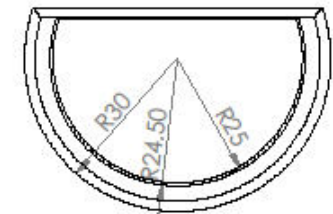
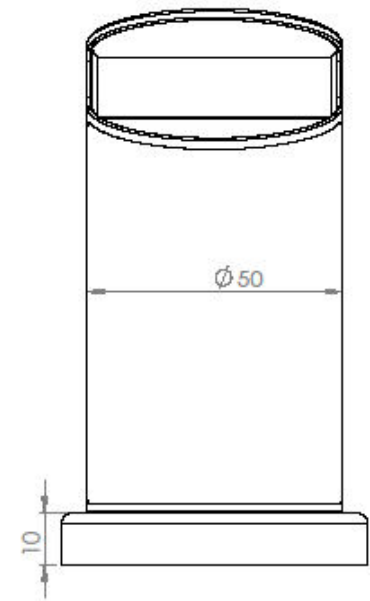

Bollard @ 90 cm distance on the street

Final concepts

Plan of bus stop and kiosk

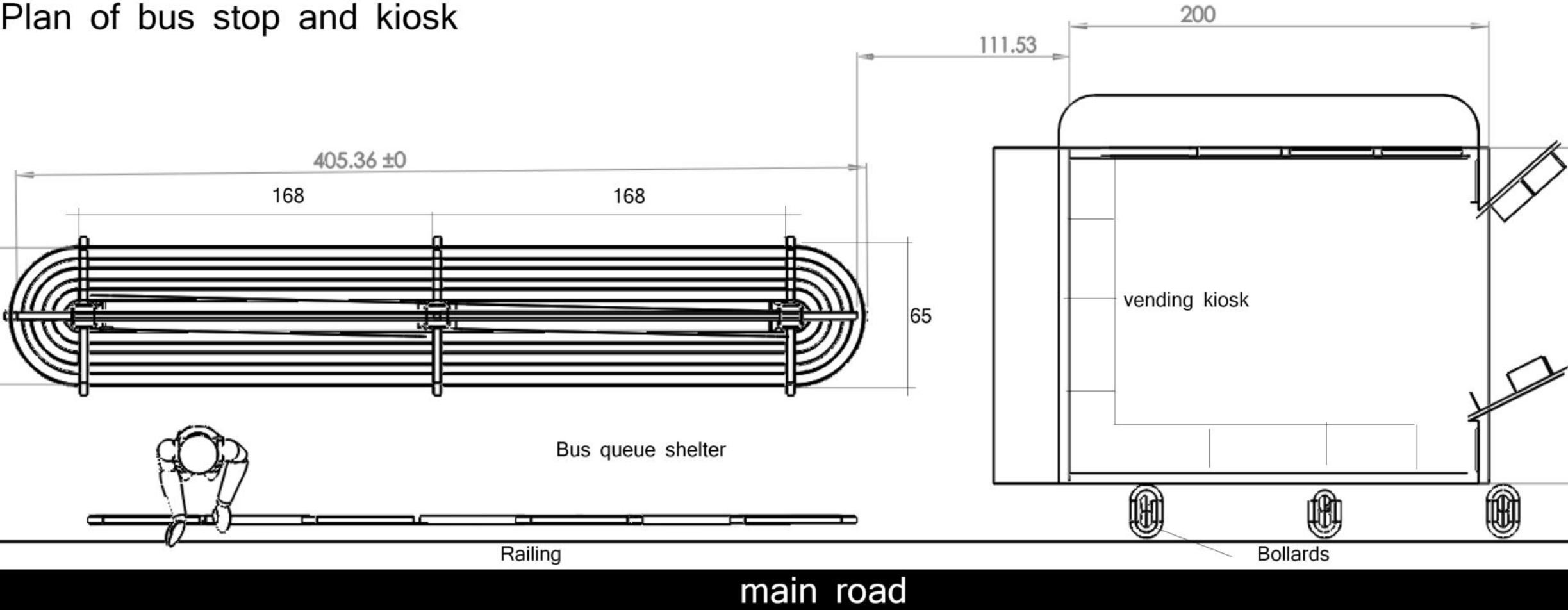

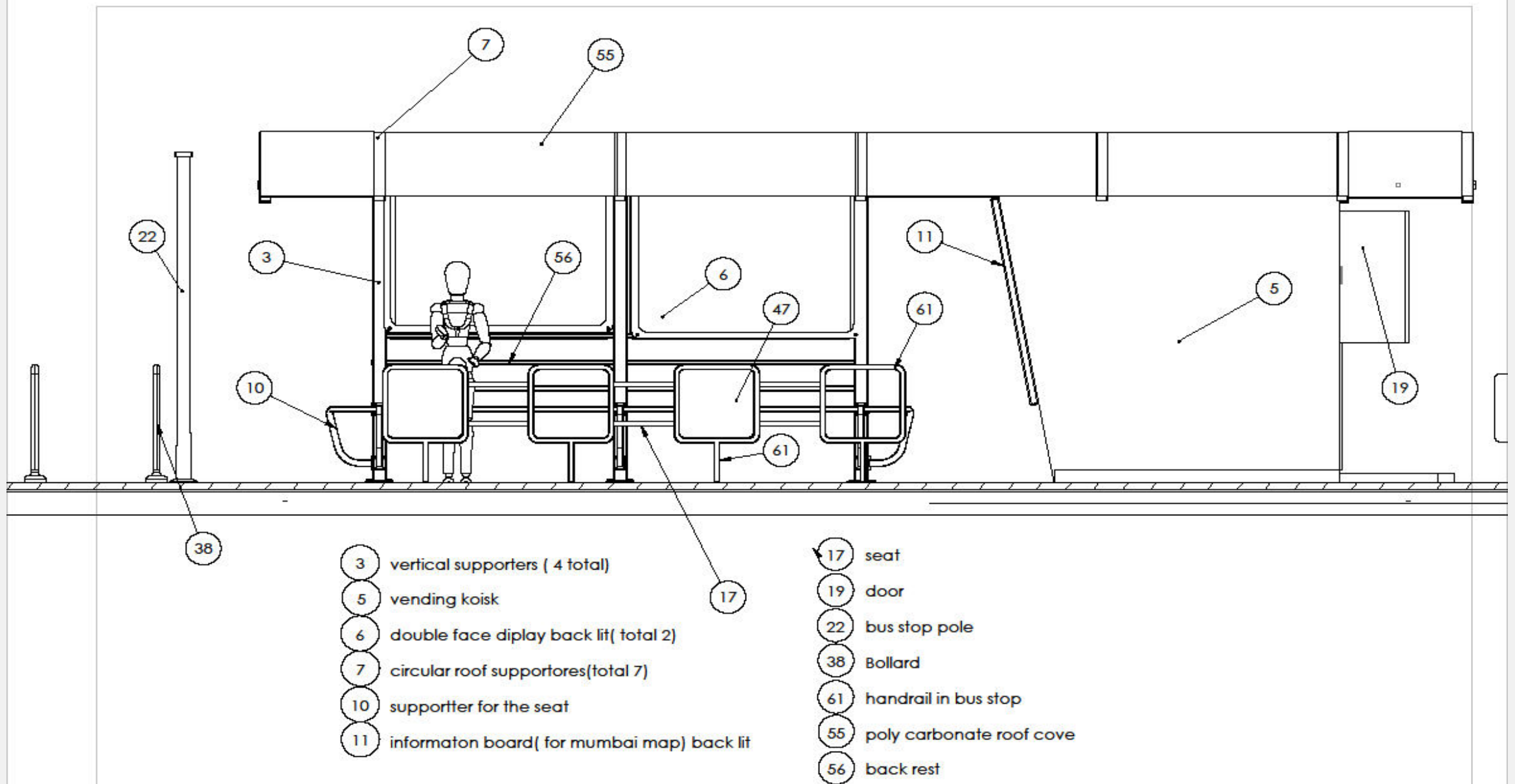

Detail drawing

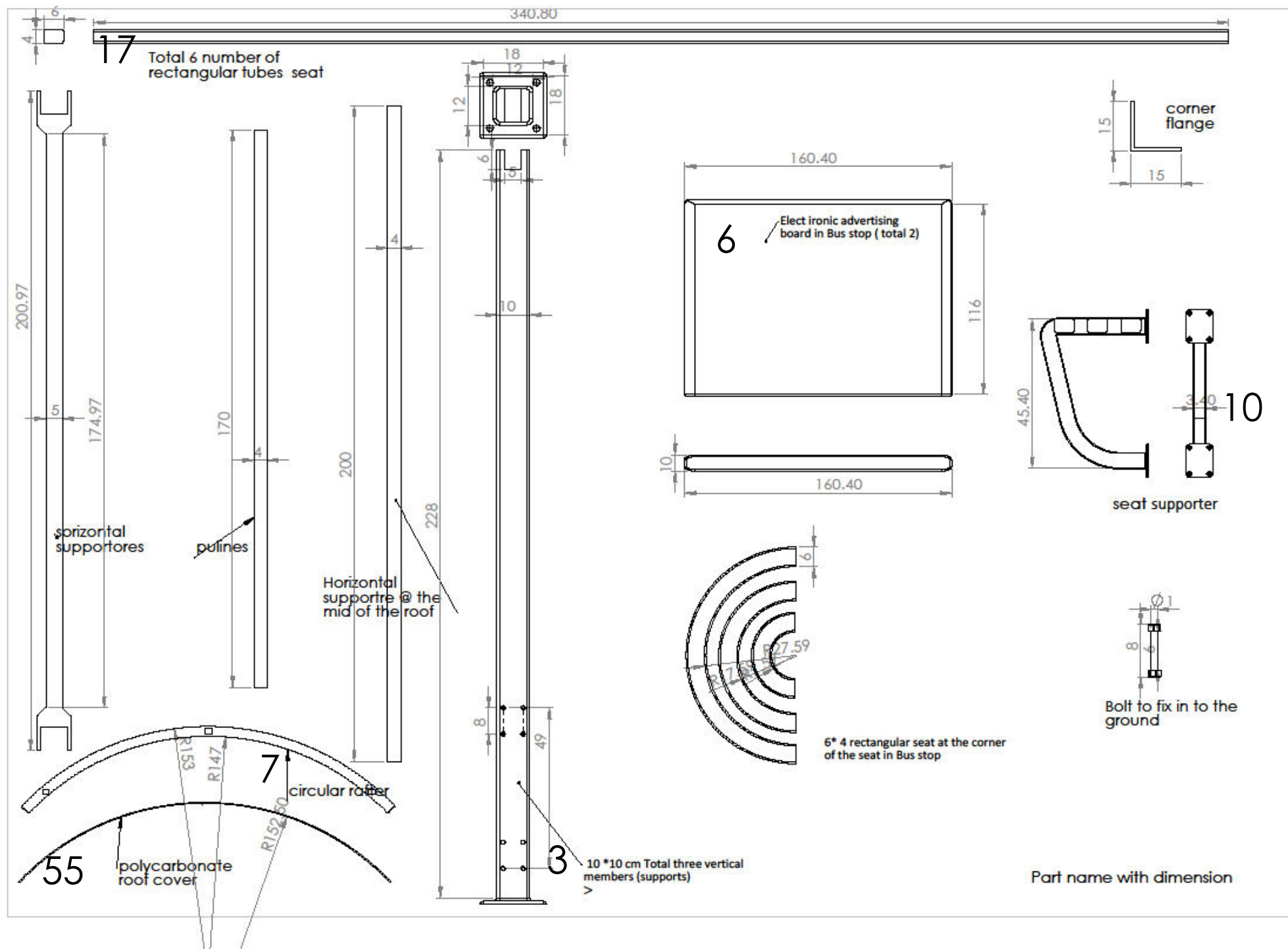

Final rendering of bus stop with vending kiosk



Final rendering of bus stop



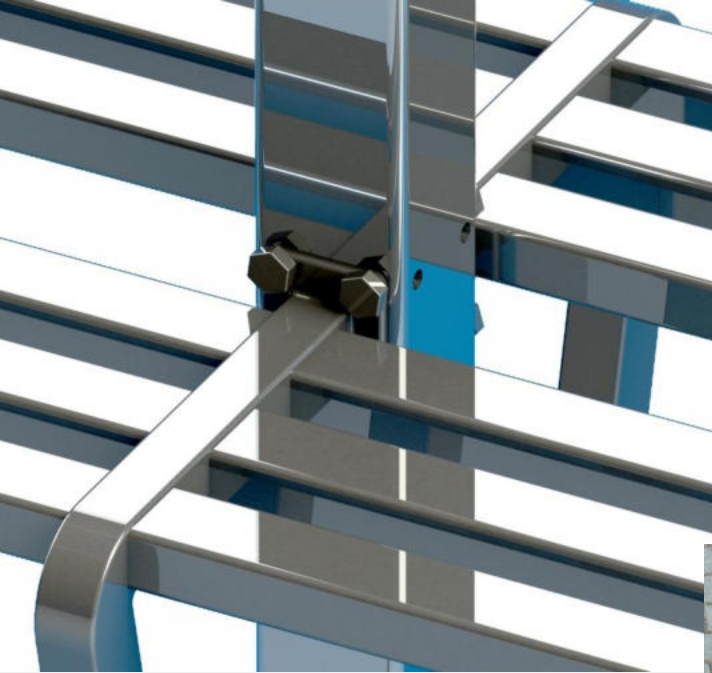

4*6 cm Staines steel rectangular tube
Seat



Eave detail

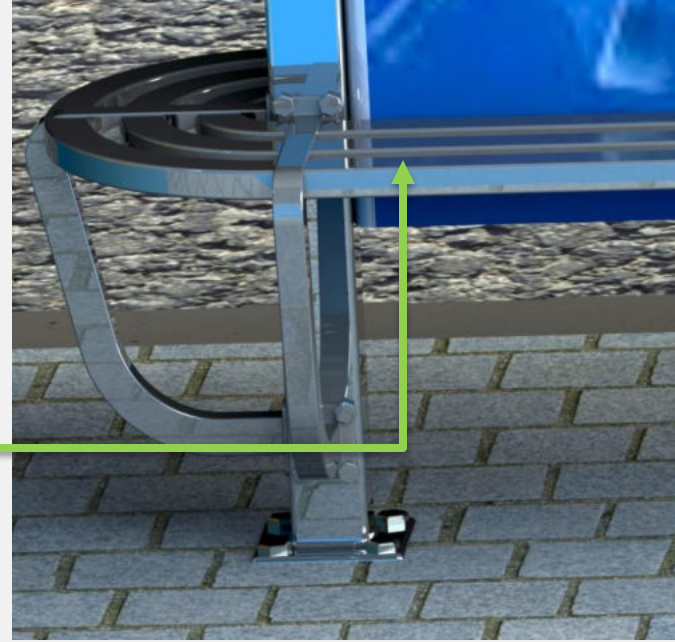

Seat on the corners

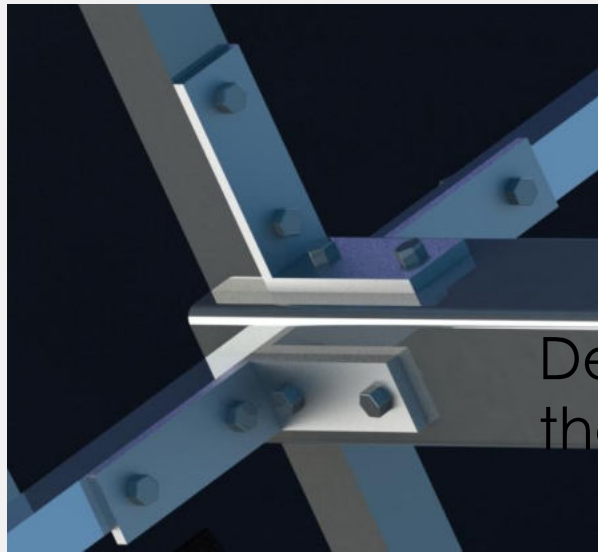
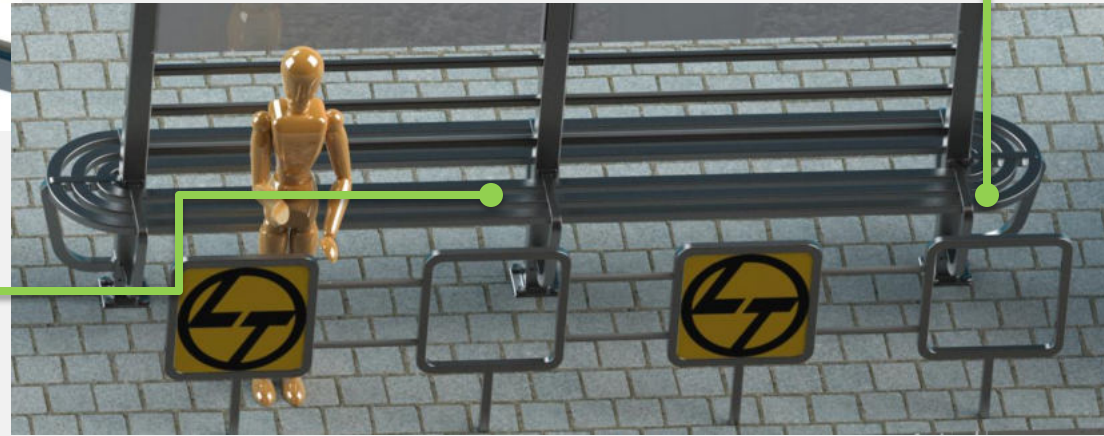

Detaille on the roof

15 * 15 cm rectangular tube stainless stainless steel column



Advertisement on walls

Rectangular
steel frames

wall

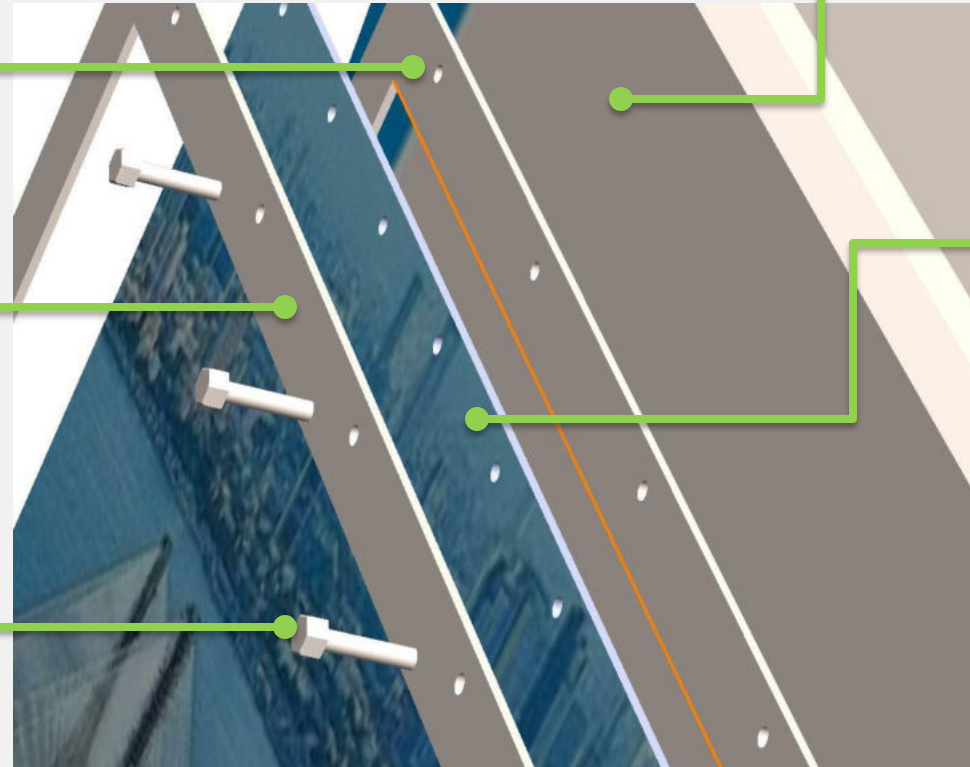

Printed panel
for
advertisement

Bolts or screw

Site location plan where each furniture item is located



KEY

- Bus Stop(2)
- Vending Kiosk(2)
- Bench(35)
- Bollard(@ 90 cm in the street where it is needed)
- Public Convenience (3)
- Litter Bin(in each bus stop and vending kiosk and @ 200m on the lake side)

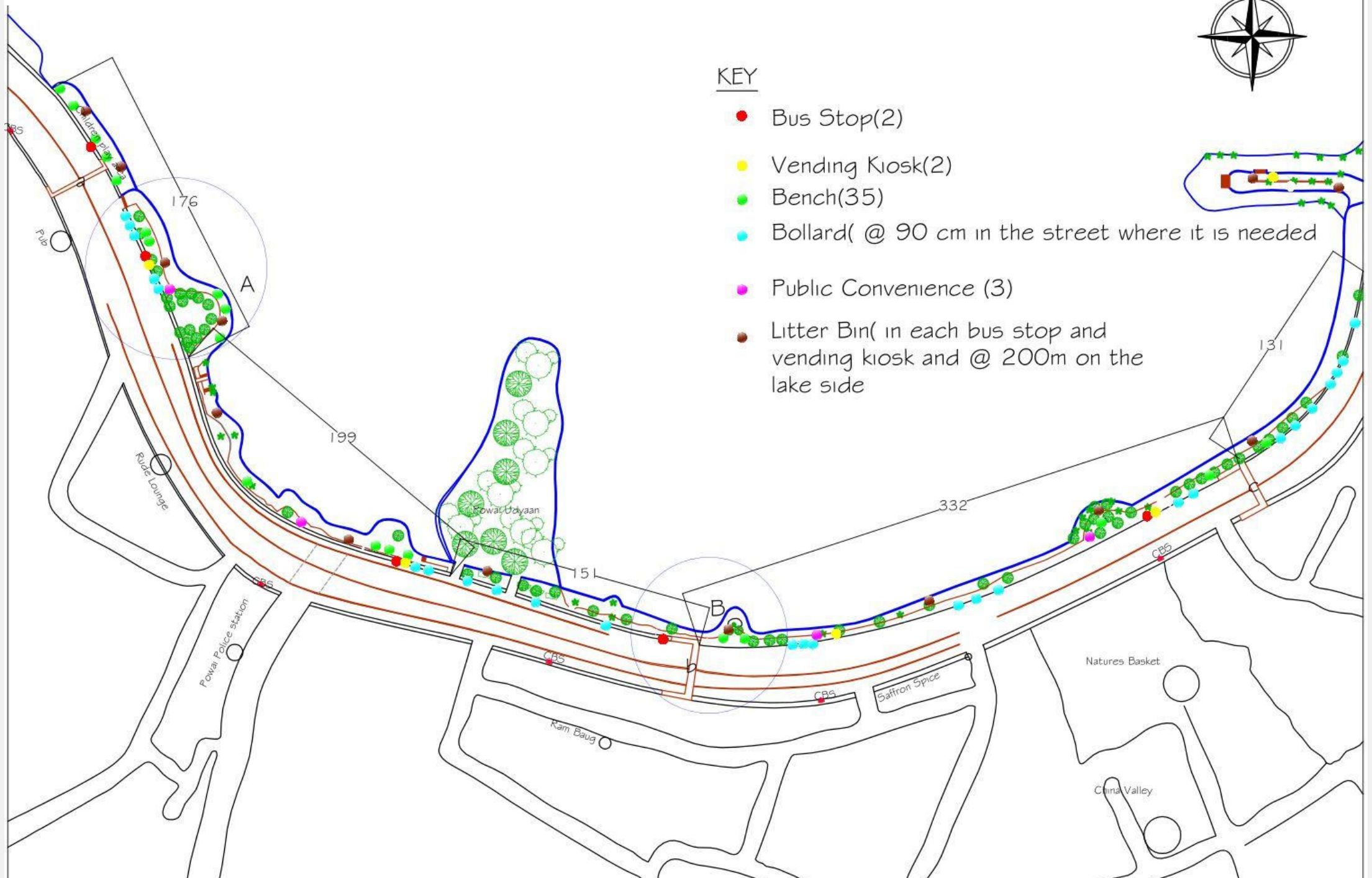

A

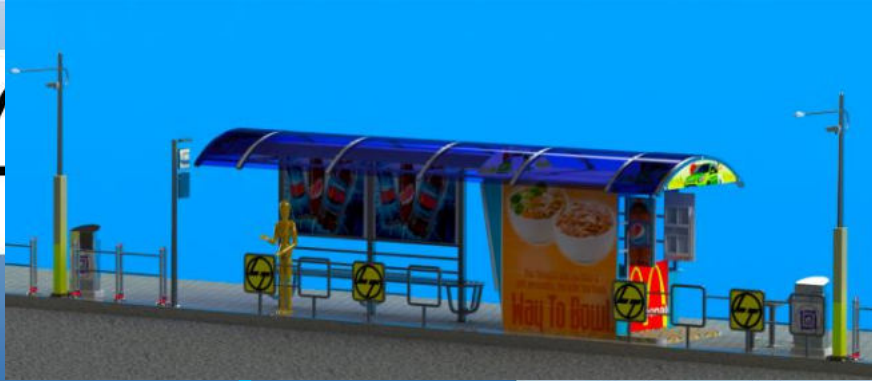

street

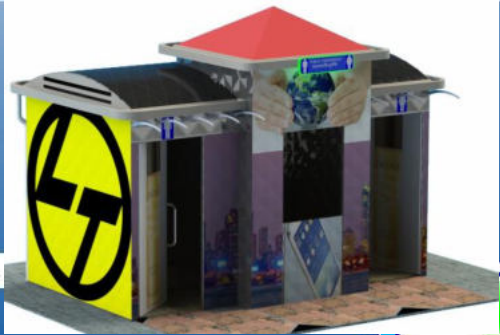

Litter Bin(in each bus stop and vending kiosk and @ 200m on the lake side

X

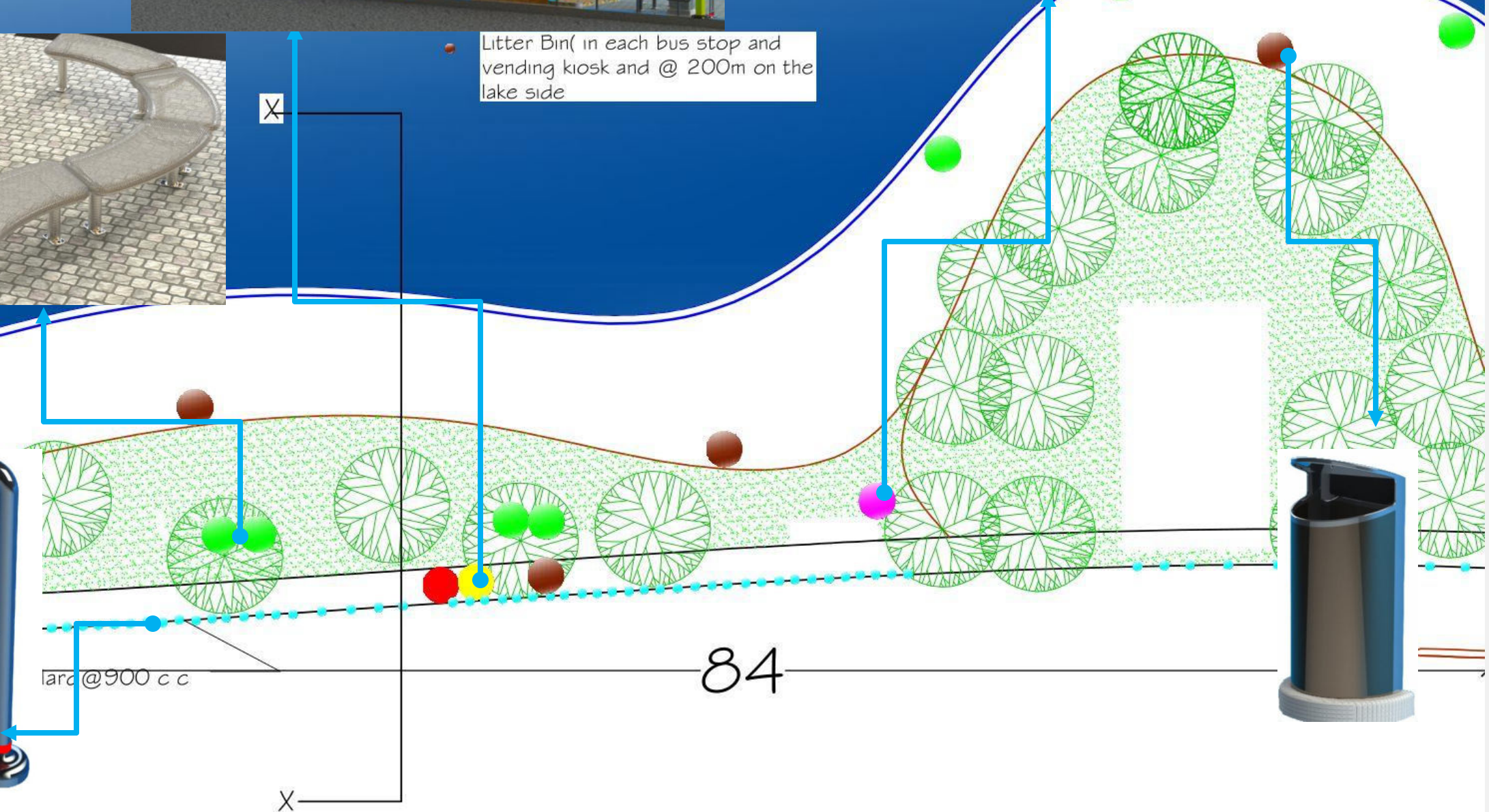

lard@900 c c

84

X

