

# Water taxi for inland water ways-Kerala

Design project III

Project guided by - Prof. K Ramachandran

By - Unni Mohan M

126390006  
Mobility & Vehicle Design  
IDC,IIT Bombay

# Genesis

Article



Initial study



- There are 67 navigable rivers in the state.
- Peculiar feature of Kerala -Canals link the lakes and backwaters to form an uninterrupted inland water navigation system from Thiruvananthapuram to Vadamkara - a distance of 450 kms.

# Research

## Inland Water Transport



*Waterways are the cheapest means of transport. They are most suitable for carrying heavy and bulky goods. It is a fuel-efficient and environment friendly mode of transport.*

## Cost-effective and eco-friendly option

- IWT developed along existing rivers, canals and waterways-no question of land acquisition.
- The per km cost of development of a waterway is insignificant compared rail or highway.
- The maintenance cost of a waterway is also less.
- The time taken to develop waterway routes is negligible.
- IWT more environment-friendly than either road or rail.
- Congested roads and indisciplined drivers -accidents on highways.
- The least hazardous mode of transportation.

## Notable Inland waterway around the world

Venice



Bangkok - Thailand



## Inland vessels

- Inland vessels are usually less sturdy than ships built for the open seas, with limited navigational and rescue equipment,
- Not to survive the high winds or large waves characteristic to large lakes, seas or oceans.
- They can thus be built from light composite materials.
- They are limited in size by width and depth of the river as well as the height of bridges spanning the river.
- They can be designed with shallow drafts,.
- Ferryboat is often used to cross a river, Riverboat is used to travel along the course of the river.

## Inland Water ways-India

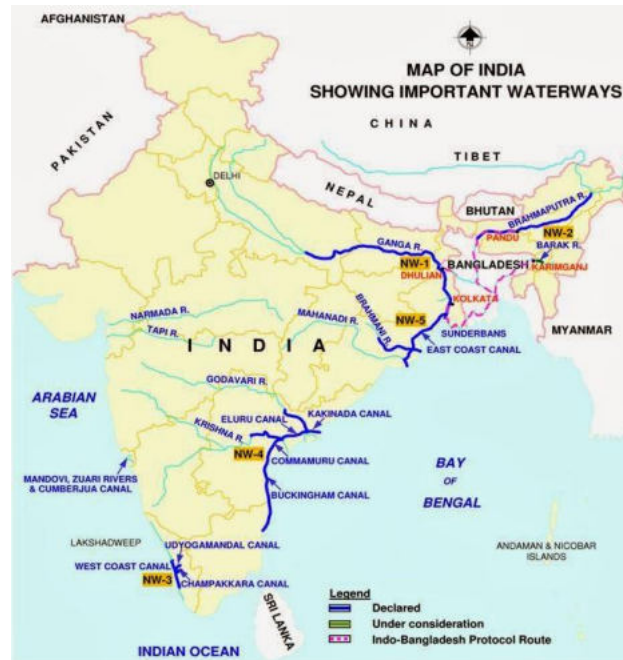

- Inland navigation waterways of 14,500 km in length.
- 3,700 km are navigable by mechanized boats.
- In India, only 0.15 per cent of domestic surface transport is done through this route.
- Roads and railways continue to be the bulk carriers

Waterways declared as the National Waterways-

1. The Ganga river between Allahabad and Haldia- N.W.-1.
2. The Brahmaputra river between Sadiya and Dhubri (891 km)- N.W-2.
3. The West-Coast Canal in Kerala (Kottapurma-Komman, Udyogamandal and Champakkara canals-205 km) – N.W.-3.
4. Godavari & Krishna rivers & Canals between Kakinada and Puducherry (NW-4.)
5. The East Coast Canal stretch along with Brahmani and Mahanadi delta river system is defined as NW-5.
6. Barak river from Bhanga to Lakhimpur(121 km) in the State of Assam.

# Inland Water ways- Kerala

## Historic relevance

- Canals link the lakes and backwaters to facilitate an uninterrupted inland water navigation system from Thiruvananthapuram to Vadakara, a distance of 450 kms.
- Kuttanad in Alappuzha district alone has more than 20 per cent of India's total length of waterways.

## The Varkala canal.

The Varkala canal runs parallel to the Arabian Sea and NH 47. This canal was built by linking the natural water bodies. The conditions of the canal do not allow navigation now.

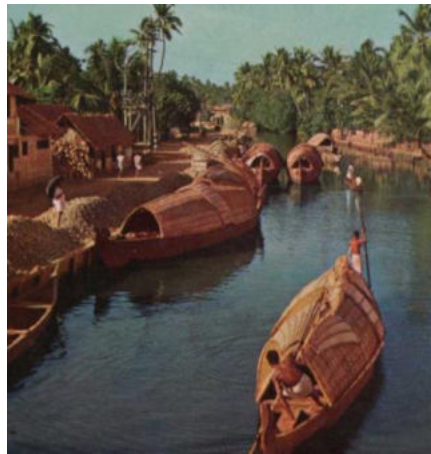

## The Varkala tunnel

Magnificent feat of Engineering - The Varkala tunnel.

- The 722-m-long Sivagiri tunnel and the 355-m-long Chilakoor tunnel in the stretch are the main bottlenecks in the waterway.
- The Sivagiri tunnel, completed in 1880, is reported to be the only one of its kind in Asia.
- It was given a facelift in 1942.
- The tunnel was navigable till 1970.
- The National Transportation Planning and Research Centre (Natpac) has suggested several improvements for the tunnel at Varkala to commence boat services.
- The tunnel rises to a height of five meters, siltation restricts the air draft to only 1.3 meters now.





## Kerala State Water Transport Department

**Boat Capacity** - 50 to 150 passengers (wooden boats)

**Speed of operation** - 10 to 15 km per hour

**Boat Size**- Length: 20 to 35 meters, Width: 3 to 4.5 m, Depth: 2 m

**Empty Weight** - 5 to 15 tons

**Crew per boat** - 5 max.



## A host of issues

- As per norms, NW III must have a two-meter depth and 32-metre width so that even huge barges that transport 600 tones of goods may safely use them.
- Land owners on either side welcome depositing of sand on their premises, but are opposed to depositing of slush.
- Fishing nets erected illegally on water bodies too stifle the movement of boats.
- Lorry lobby



## Tourism

- Kerala was placed among the '50 destinations of a lifetime' by National Geographic Traveler in a special collectors' issue released just before the turn of the millennium.
- The kettuvallams (Kerala houseboats) in the backwaters are one of the prominent tourist attractions in Kerala. More than 2000 kettuvallams ply the backwaters. Kerala government has classified the tourist houseboats as Platinum, Gold and silver.
- Thatched roof covers over wooden hulls, 100 feet (30 m) in length, provided protection from the elements. The houseboats have become floating cottages having a sleeping area, with western-style toilets, a dining area and a sit out on the deck. Kettuvallams are motorized but generally proceed at a slow speed for smooth travel.



## Future Potential

- 74 km Kovalam- Kollam stretch of the waterway is included as a part of the Smart Waterway project of the Central Govt.
- Works for widening the canal to 14 meters and to a depth of 2.2 m and restoration of the Sivagiri tunnel to complete the linking of the stretch to the National Waterway have started.
- Roads are clogged, railways are overburdened, water transport as an alternative reduce the nightmarish congestion on roads.
- It will also be far more economical than widening the existing roadways or building new roads in the densely populated state.
- While National Highways are being upgraded to 45-meter-wide, Kerala state government has requested NHAI to reduce the width of National highways in the state to 30-meters.

## Related articles

### THE HINDU BusinessLine

[Home](#) [News](#) [Markets](#) [Companies](#) [Tech News](#) [Economy](#) [Opinion](#) [Features](#) [Blogs](#)  
[National](#) [International](#) [Sports](#) [Politics](#) [Science](#) [Travel](#) [Education](#)

**Kerala Govt plans movement of petro products thru waterways**

### THE HINDU

[Home](#) [News](#) [Opinion](#) [Business](#) [Sport](#) [S&T](#) [Features](#) [Books](#) [In-depth](#) [Jobs](#) [Classif](#)

TODAY'S PAPER » NATIONAL » KERALA

KOCHI, November 27, 2013

**Protesters against highway widening show no work done on acquired land**

# Kerala Naval architecture\icons

Chundan Vallam - Speed and  
performance

Chundan Vallam (Beaked Boat), known to the outside world as Kerala snake boats, are one of the icons of Kerala culture used in the Vallamkali (boat race).

- Traditionally each boat belongs to a village.
- Only men are allowed to touch the boat, and barefooted.
- The Snake Boat Race of Kerala boasts of being the largest team sport in the world is a magnificent fiesta that brings alive the tranquil backwaters.



- About 83 feet length & 6 inches thick long wooden planks are used for the construction of the hull.
- The boats is 158 feet long and holds 107 men.
- Head & tail will project 5 & 3 feet above the water level. 64 seating compartments -represent the 64 art forms.
- 4 Master oarsmen (representing 4 vedas) are seated at the head of the boat, with large controls the direction of boats.
- Boat is coated with animal fat boiled with lime but the inside is usually smeared with fish oil.
- In order to make the boat slippery in water, coconut shell carbon, eggs & fish oil are used.

## Kettu Vallam - Luxury and comfort

- The original kettuvallams were used to transport rice and spices about 30 tons, from Kuttanad to the Kochi port.
- Present day houseboats are huge, slow moving exotic barges used for leisure trips.

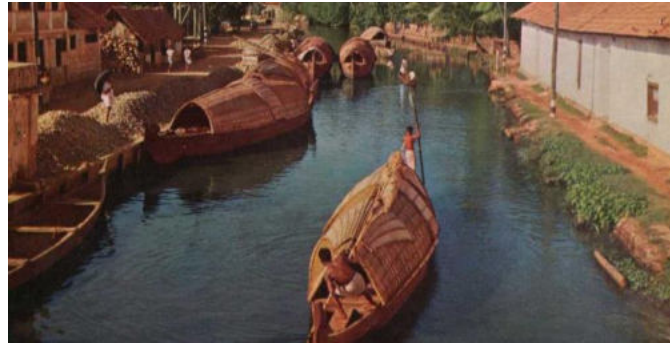

## Features

- The kettuvallam is held together with coir knots. The boat is made of planks of jack-wood joined together with coir.
- This is then coated with a caustic black resin made from boiled cashew kernels.
- A portion of the kettuvallam was covered with bamboo and coir to serve as a restroom and kitchen for the crew.
- In Alappuzha alone, there are as many as 500 houseboats.
- Bamboo mats, sticks and wood of the areca nut tree are used for roofing, coir mats and wooden planks for the flooring and wood of coconut trees and coir for beds.
- For lighting though, solar panels are used.

# Climatic conditions

- Kerala has hot and humid climate during April-May and pleasant,cold climate in December-January. Summer extends from the month of April to June. During this period the temperature reaches to a maximum of 33 degrees centigrade.
- South West Monsoon that starts pouring in the month of June and continues till September,with the increase in humidity.
- The North East Monsoon begins in the month of October and stops at the end of December.
- Occasionally very little rainfall accompanied by thunder and lightning takes place in the northern region of the state.
- Highest rainfall is received by Kottayam during this winter season.

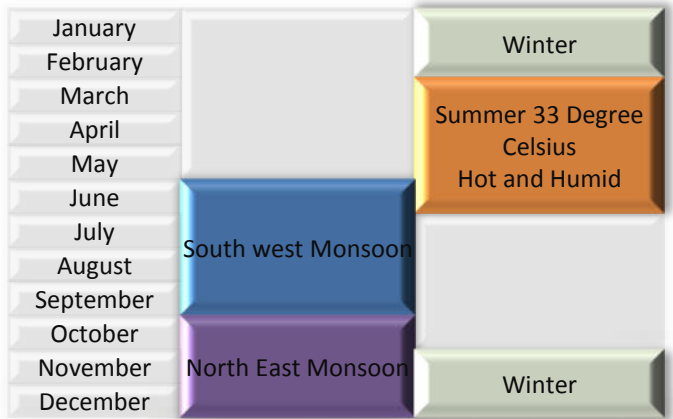

## Takeaway from research

### Observations

- Native and gifted waterways.
- Historically water ways were life line for people movement and also for goods.
- Economical and environment friendly.
- NW-3 runs almost parallel to NH-47.
- Varkala tunnel and canal are magnificent feat of engineering.
- India's first NW to become 24hrs operational.
- Highly used for tourism.
- Kerala has two iconic navel architecture- Chundan Vallam and Kettuvallam.
- State water transport dept. active but localized to small part.
- Strong presence of monsoon in the state.
- Comfortable and refreshing travel experience.
- Works ongoing for elongation of water way from kollam to Trivandrum.
- Many govt. projects on maintenance and development.

### Comments

- Water travel experience remains same in terms of ride comfort but in road transport, surface condition matters.
- Road going experience is never beautiful as water ways.
- Congested and accident prone National highways.
- Over burdened railways.
- Unlike other NW,Nw-3 has combination of rivers and lakes (which keeps floods under control and remains operational almost all seasons).
- Kerala highways are only 45 m compared to national width of 60m.Protest at many part restricting it to go beyond 30m width.
- Current water transport vessels are large and slow (average speed of 15 km/hr. ).
- Family privacy(trains offers best travel comfort,but lacks privacy,especially for family).
- Water ways,a sensible transportation model for densely populated Kerala.

# Field study

## Long distance journey

Alappuzha - Kollam/Kollam-Alappuzha  
backwater cruise

Journey time 8 hours

- Departure: 1030 hrs. from DTPC boat jetty.
- Fare: Rs 300 per head.
- No of seats- 80.



Observations.

1. Only two halts-one for lunch and other for tea.
2. Toilet inside the boat is convenient.
3. Upper deck highly preferred by travelers.
4. During Initial hours,travelers enjoyed scenic beauty.
5. As time passed,tourists moved into reading book and other activities.
- 6.Strong sound and vibration from diesel engine filled the cabin.
- 7.Smell of oil,diesel and occasional entry of smoke in the cabin.
- 8.Seat comfortable for 8 hrs.
- 9.Airy feel of cabin was inviting.
- 10.Water cooled engine.
- 11.No nights trips (excessive reflection from the water surface).

Observations.



*Boat roll while ingress and egress.*



*In narrow channel, boat tends to move and hit the walls.*



*Bored with lengthy travel.*



*Waves from other boats affects the ride.*



*Small size of vessel could improve average speed.*



*Size seems good for speed and crowded parts of waterways.*

# Study of Chundan vallam

## Observations

- Crafted by hand.
- Centre part is first constructed in inverted position with the help if jigs.
- Tail design is made at the end and is left with the creative mind of master at that point of time.
- Rear has to look like a snake with head held high. This gives visual dominance to the boat. Visually rear looks heavy.
- The tall rear helps the master oarsman to command the boat with fine control.
- Rear is enriched with fine craft work and brass ornamentation.



# Chundan Vallam

Observations



# Takeaway from Field study

## Observations

### Long distance journey

- 6.5 hrs. for a distance of 86 km.
- Tiresome because of sound and vibration of diesel engine.
- Boats does not give a feel of safety from outside,presence of life jackets inside gives confidence.
- Rolling of boat while ingress and egress scare first time travellers.
- Toilets in side a must,as unlike roads the cannot be stopped near banks easily.
- It could easily penetrate inside town.
- Reflection from water-less night trips.
- Boats never have a complete stop.
- Speed equivalent to 12km/hr.
- Small size boats could move through house boats and other vehicles easily without slowing down.

### Short distance journey-

Used by people as the only source of transport, the journey and travel experience has become a part of culture for the users.

## Comments

- Lengthy journey.
- Great visual experience .
- Boats has been associated with the fear of capsizing.
- Rolling of boat not very inviting.
- Passengers finds difficulties with ingress and egress.
- Engine could be isolated from cabin.
- Roads towards district capital are heavily clogged,boats have an advantage here.
- Solution for night journey.
- Boat journey can offer better privacy compared other means of transport.

# Vehicle idea

Indicators to a new vehicle.

- Time spent in travel should be actually spent for it in comfort - Congested roads and over crowded railways.
- Idea about a vehicle which can be hired to travel long distance in water and offers better privacy and space especially with family.
- Vehicle which can offer better space for passengers especially for travelling long distance. Road vehicles have space limitations (other than custom build). Railways cannot offer personal space or privacy.
- Water vehicle can offer better space than road vehicles and better travel experience than trains.
- A big mpv in water.
- Other than railways, a vehicle going experience reminds us about the presence of engine or propulsion system.

## Vehicle idea

A fast water vessel which can be hired for long distance travel?

Examples around the world?

## Water taxi



# Benchmarking

## Water taxi

### Water taxis around the world

- A water taxi or water bus, also known as a **commuter boat**, is a watercraft used to provide public transport, usually but not always in an urban environment.
- Service may be scheduled with multiple stops, operating in a similar manner to a bus, or on demand to many locations, operating in a similar manner to a taxi.
- A boat service shuttling between two points would normally be described as a ferry rather than a water bus or taxi.
- The term water taxi is usually confined to a boat operating on demand, and water bus to a boat operating on a schedule.

### San Pedro water taxi



- The boats are completely covered and are powered by three 250 HP Yamaha out board four-stroke engines. This makes the ride vibration, smoke and noise free..
- The seats are completely padded with back-rest, head-rest and hand-rest.
- The boats can carry a sixty passengers.

Dubai -Water taxi



Yellow Water Taxis Sydney Australia



Hydrogen-powered ferry service - Bristol



The Beirut Water Taxi



## Other examples of interest

### Cabin cruiser

- A **cabin cruiser** is a type of power boat that provides accommodation
- A cabin cruiser usually ranges in size from 25 to 45 feet (7.6 to 13.7 m) in length, with larger pleasure craft usually considered yachts.
- These craft are generally equipped with a head (toilet), a galley, and at least one berth.



### Yacht

- Yachts are different from working ships mainly by their leisure purpose,
- A luxury craft smaller than 12 meters (39 ft.) is more commonly called a cabin cruiser or simply a cruiser. A superyacht generally refers to any yacht (sail or power) above 30 m (98 ft.) and a megayacht generally refers to any yacht over 50 meters.



## Catamaran

- A catamaran is a multihulled vessel consisting of two parallel hulls of equal size.
- A catamaran is geometry-stabilized,.
- A catamaran can have a very shallow draught. The two hulls will be much finer than a monohull's, the reduced drag allowing faster speeds.

### Features

- Catamarans, specifically the multi-hulls, are normally faster than single-hull boats.
- The major increase in speed over a monohull is due to the hull shape. Catamarans make use of needle like hulls which significantly reduce wave drag.
- Catamarans are typically lighter and thus have less displacement (weight). They don't require a keel counterweight since righting moment is derived from the spacing between multiple hulls.
- Catamarans have a wider beam (the distance from one side of the boat to the other), which makes them more stable and therefore able to carry more sail area per unit of length than an equivalent monohull.

- A catamaran is most likely to achieve its maximum speed when its forward motion is not unduly disturbed by wave action.
- This is achieved in waters where the wavelength of the waves is somewhat greater than the waterline length of the hulls, or it is achieved by the design piercing the waves.
- Thus catamarans are especially favorable in coastal waters, where the often sheltered waters permit the boat to reach and maintain its maximum speed.



## Solar catamaran Solon C60

- With a length of almost 18 meters and a width of 7 meters, the Solon is driven by two electric motors, which speed the Catamaran to a maximum speed of up to 15 mph.
- With sunny weather the solar panels on the roof guarantee the ability to run indefinitely.
- The shape of the ship was optimized under bionic aspects.
- The double hulls contain a tunnelled propeller system, which guarantees a high efficiency propulsion and thus takes much less surface water in. Additionally, it protects the propeller from touching the ground.



## Planet Solar

- The largest solar-powered boat in the world.
- In May 2012, it became the first ever solar electric vehicle to circumnavigate the globe.
- The 31-meter boat is covered in over 500 square meters of solar panels rated 93 kW, which in turn connect to one of the two electric motors in each hull.
- There are 8.5 tons of lithium-ion batteries in the ship's two hulls.
- The boat's shape allows it to reach speeds of up to 14 knots.



# Vehicle Image

## Inputs for the new vehicle

### A water taxi

- Hired for long distance travel in NW-3.

### Size

- Big enough for comfort and
- small enough go fast maneuver around.

### Travel experience

- Comparable or even better to a good road travel experience.
- Advantages of inland waterways (decongested and comfortable).
- Speedy enough to attract road users.

### With

- navigational aids for night and safety
- Good seating,
- privacy,
- spacious cabin,
- facilities (toilet, luggage).

Initial images supporting the thoughts.

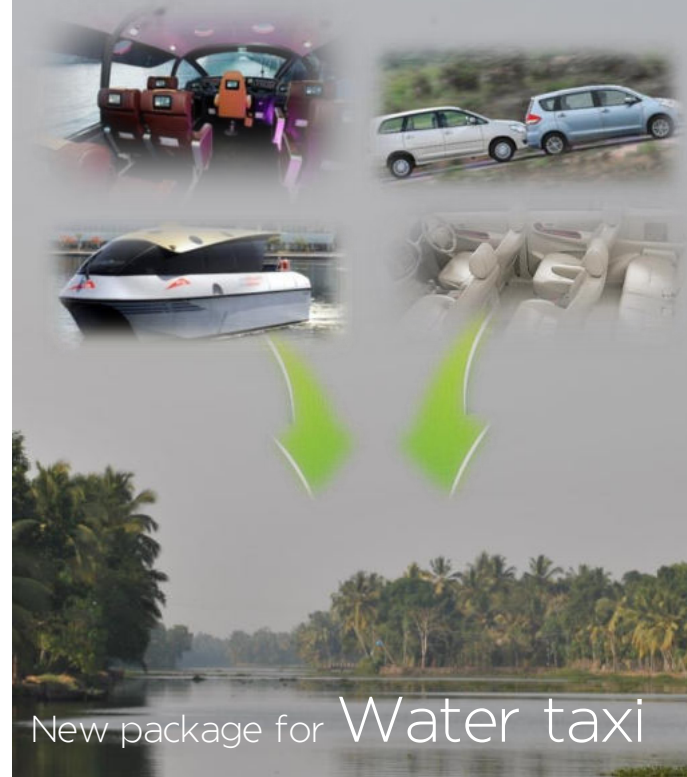

## Water taxi to

### Users-

- Family hiring mpv or taking personal vehicles.
- Tourists-domestic and international.
- Business trips.

### Experience-

- Can be related to a comfortable mpv experience (comfortable road experience which can be hired by masses.)
- with better space ,privacy and comfort (than rail and road)

### Distance and speed-

- Average distance between district capitals along NW-3 is 70 km (total distance of 250 km).
- Average speed equal to or greater than NH-47 which runs parallel to NW-3 .

## Additional inputs

Discussion and feedback from guide.

- Good over night travel experience (seating + light experience).
- Ingress and egress during rains.
- Feel of safety without being loud.
- Interior seat configuration-  
flexible  
interactive,  
relaxing for sleeping,  
conferencing,  
individual entertainment.
- Idea about isolating engine.
- Separating driver from cabin.

# Design considerations

## Boat architecture selection

### Catamaran Pros

- Roominess
- The cockpit, is usually huge, since it spans over both hulls. Light and spaciousness,
- As a result of this roominess, a catamaran rarely feels crowded.

### Stability

- Catamarans have a phenomenal stability:
- They do not heel under way and do not roll at anchor, no seasickness.
- Stability is also a good factor for elderly people and/or first time traveler..
- Catamaran excellent impression for their first cruise

### Speed & maneuverability

- Catamarans are faster under power or sail. than a monohull.
- Catamarans have shallow drafts.
- The phenomenal maneuverability of the cats. With 2 engines spread apart, pivot around the boat's central axis and without rudders.

### Monohull

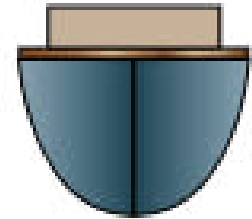

### Multihull Catamaran

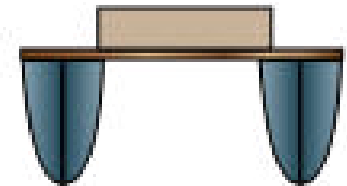

## Constraints -Dimension

The Varkala Tunnel is only five meters wide, while the standard width of the National Waterway is 14 meters.

Reversible head lock designed to control currents or water levels in either direction. The usable dimension appears to be 45m by 8.40m.

- A Kerala houseboat is on an average 70 feet (21.3m) long boats with 15 (4.5m) feet width in the central section.
- The standard width of the National Waterway is 14 meters.

Average width of house boat -4.5m.

Taking a scenario of going through two house boats on 14m NW-3 stretch,  
Space available after giving 1 m tolerance.  
 $14 - (4.5m+1m + 4.5m+1m) = 3m$

Taking above factors into account-  
3m exterior dimension is considered.



# Seating.

## Considerations-

- Good over night travel experience (seating+light).
- Feel of safety without being loud.
- Interior seat configuration-flexible interactive, relaxing for sleeping, conferencing, Individual entertainment

Based on desirable features and taking an external dimension of 3m, seating is taken as 7 (6 users+ driver) for initial exploration.



## Speed

BY Road - NH-47

Drive from Trivandrum  
to cochin

Distance =220Km

Time taken = 5hrs30min

Average speed=40Km/h

Water taxi with average speed 40 or more  
make a tempting choice

## Propulsion

Catamarans with two engines and two propeller

With 2 engines spread apart,catamarans can  
pivot around the boat's central axis and without  
rudders ,making it extremely maneuverable.

If electric propulsion is considered-battery and  
electric motor can be place in the floats allowing  
isolation and advantage of space.

Catamarans with single engines and single  
propeller.

By allowing propeller to change angle,handling  
can be greatly improved .

To explore both for initial ideation

# Sketches

Free explorations

Ideations for seating and doors.

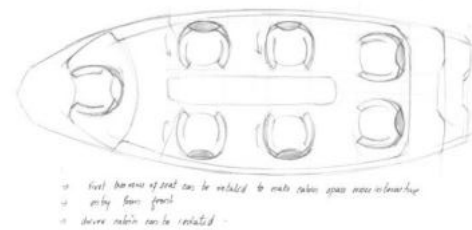
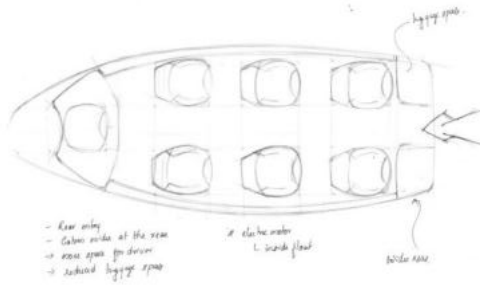
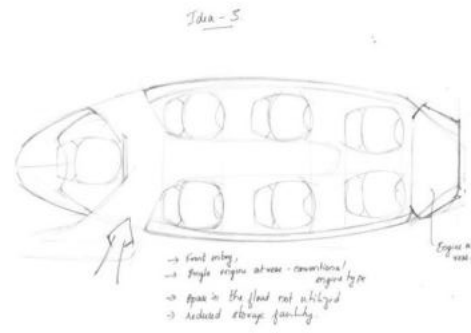
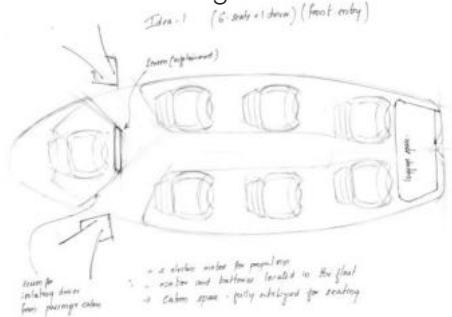

Ideations for seating - front view

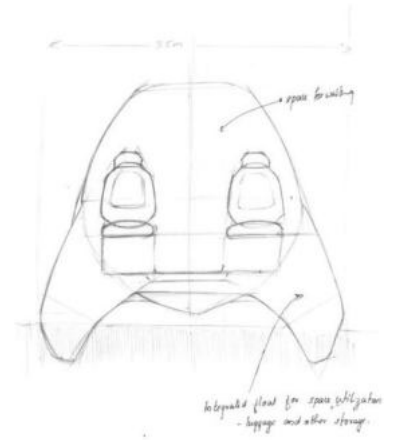
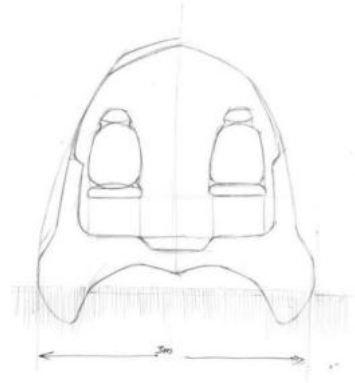

# Sketches

Ideation on float design

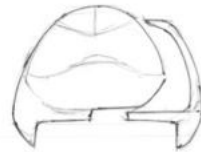
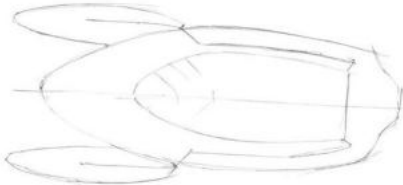
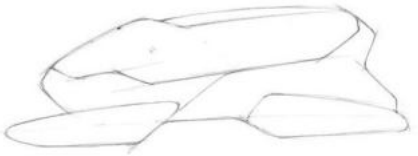
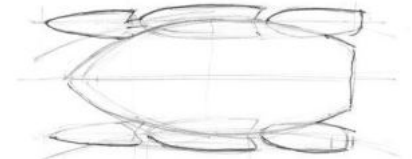
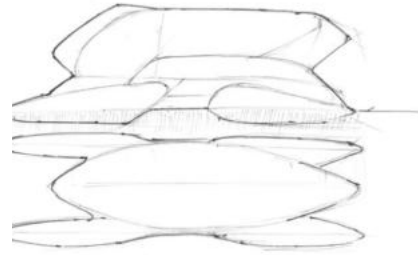
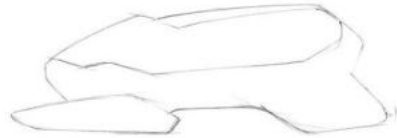
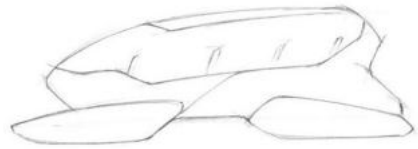

Reducing float area



flexible floats

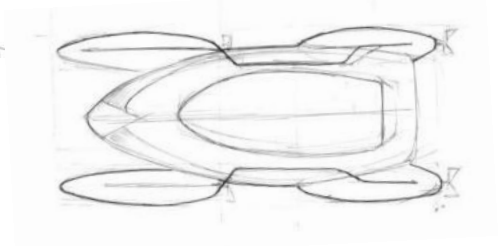
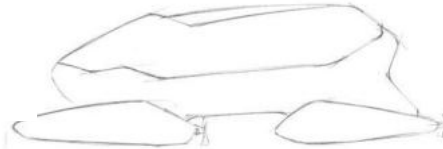
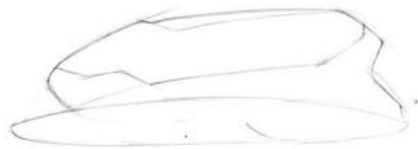

# Design brief

## Intent-

Design of water taxi for Kerala inland water ways.

## Offering-

Comfortable long distance travel experience for 6 adults plus driver.

## Cabin

Offers-

privacy, space, comfort and facilities (toilet)

Interior seat configuration-  
flexible  
interactive.

## Specifications-

- Catamaran architecture
- Design allows comfortable ingress and egress.
- Protection from rain.
- Single person control.
- Average cruising speed of 21 knots (40km/h) or above.

## Aesthetics-

- Taking design clues from naval architecture icons.
- Feel of safety without being loud.

# Human factors

## Design from Inside to Outside

Space for walking ,  
sitting(reclined) and  
movement to toilet has to be considered

# Human factors

## Anthropometric data

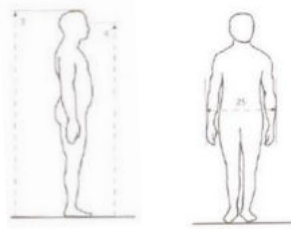

Stature

Max body width

## Facilities-Toilet.

### GLOVA Bus toilets



## Cloths and body language



- Traditional dressing Body parts exposed.
- one hand is used to hold mundu and sari while walking.

# Propulsion

## 1. Conventional IC engines

Most widely used method of propulsion in marine industry.

## 2. Electric propulsion.

Electric propulsion is faced with the problem of energy density.

Solar power cannot be considered as the prime source of power.

The energy storing capacity of batteries for a long distance service is also a matter of concern.

The option of electric propulsion makes more sense when it is considered as an auxiliary propulsion taking examples from hybrid cars which are becoming popular in present time.

Day time solar energy can be harnessed from overhead panels and used to give auxiliary propulsion.

## 3. Hybrid-IC plus electric

A combination of IC engine and electric propulsion. Energy for electric propulsion can be obtained batteries which are charged by solar power or some sort of energy recovery or regeneration. In this case IC engine acts as primary propulsion system.

## Conventional IC engines

Engine-Inboard or outboard ?

Single or double outboard engines ?

Waterjet or Propeller ?

Engine-power?

# Concept Development

## Drive and propulsion inputs

Catamaran type architecture with the center platform joining two hulls can be entirely used for cabin design as the propulsion units are either out board or placed inside floats.

## Seating layout

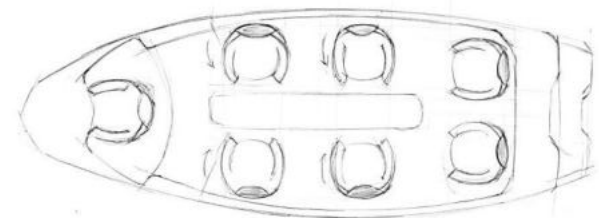

- First biomass of seat can be rotated to make cabin space more interactive
- easy from front
- diverse cabin can be isolated

# Concept Development

## Luggage placement

Following scenarios are considered for travelers in water taxi.

- Family
- Business trips
- Domestic and international tourists



### Baggage-luggage



# Concept Development

Explorations on luggage packaging

Luggage packaging -1-a



Luggage packaging -1-b



Luggage packaging -2

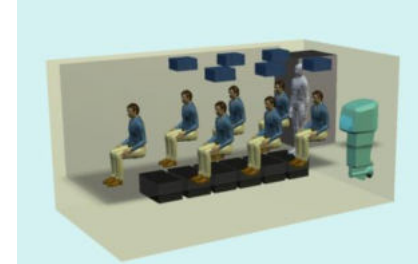

Luggage packaging -3-a

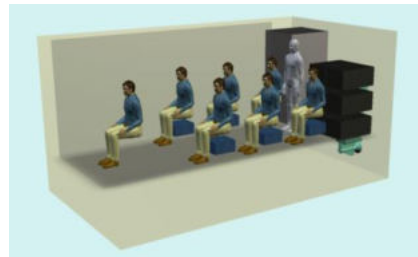

Luggage packaging -3-b

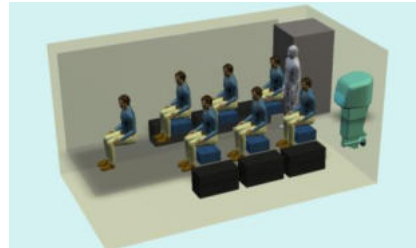

Luggage packaging -4

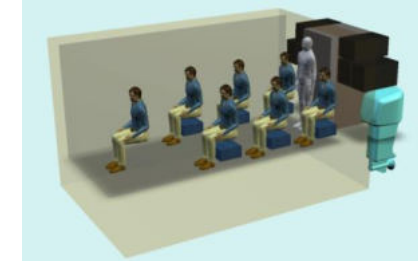

Embark and disembark



Floating Jetty



# Concept Development

Platform height

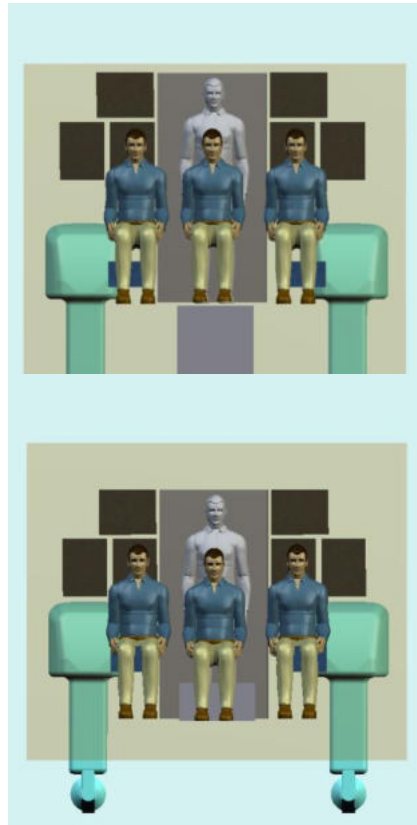

Door ideations

Considerations-

Dressing pattern -

2. Boat rolls
3. Jetty height
4. Rain

Hand rail(Inside and outside)

# Concept Development

## Seat design

Ergonomic considerations

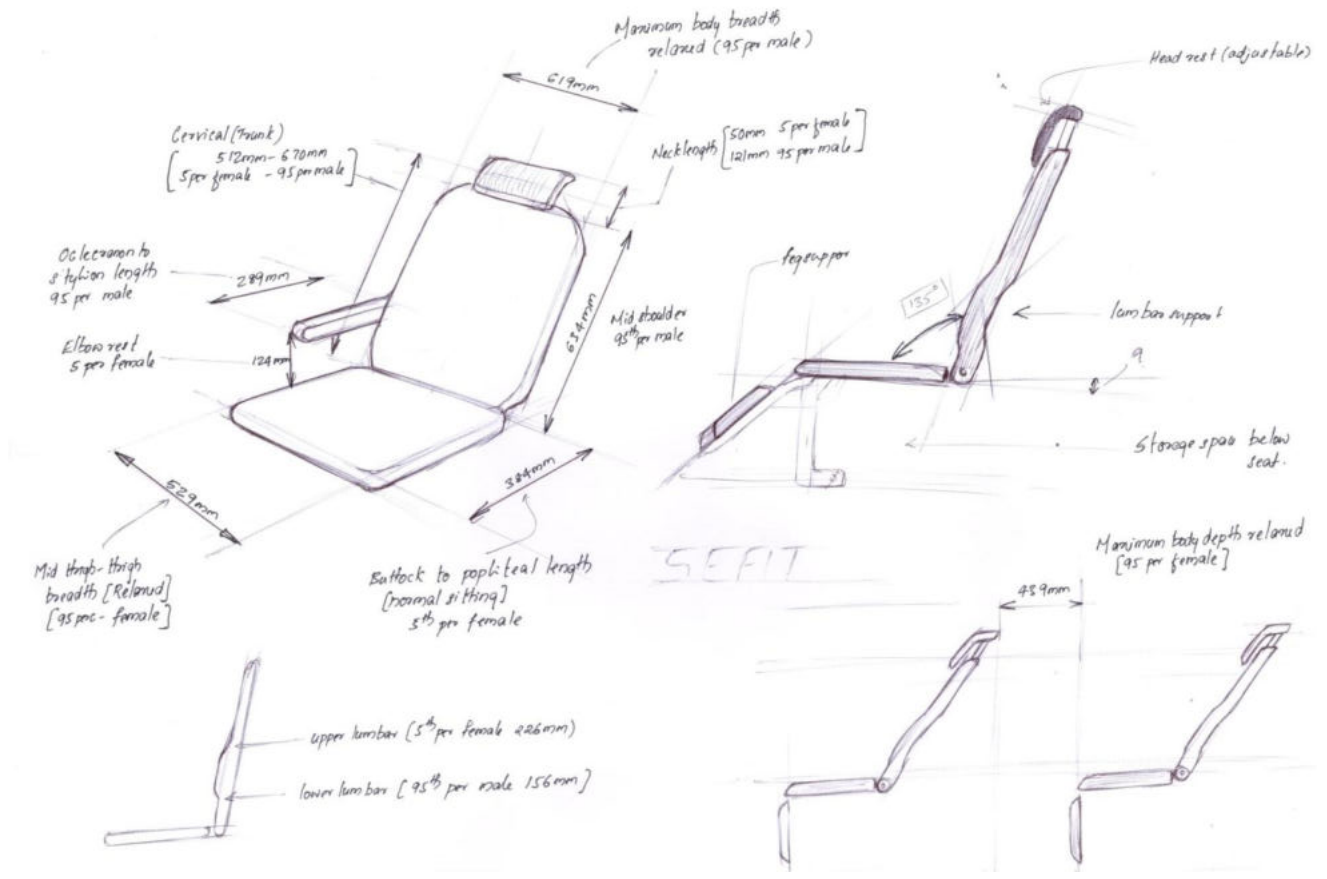

Reference -Indian anthropometric dimensions for ergonomic design practice - Debkumar Chakrabarti ,NID

# Concept Development

Seat design based on ergonomic inputs



# Concept Development

## Defining interior space

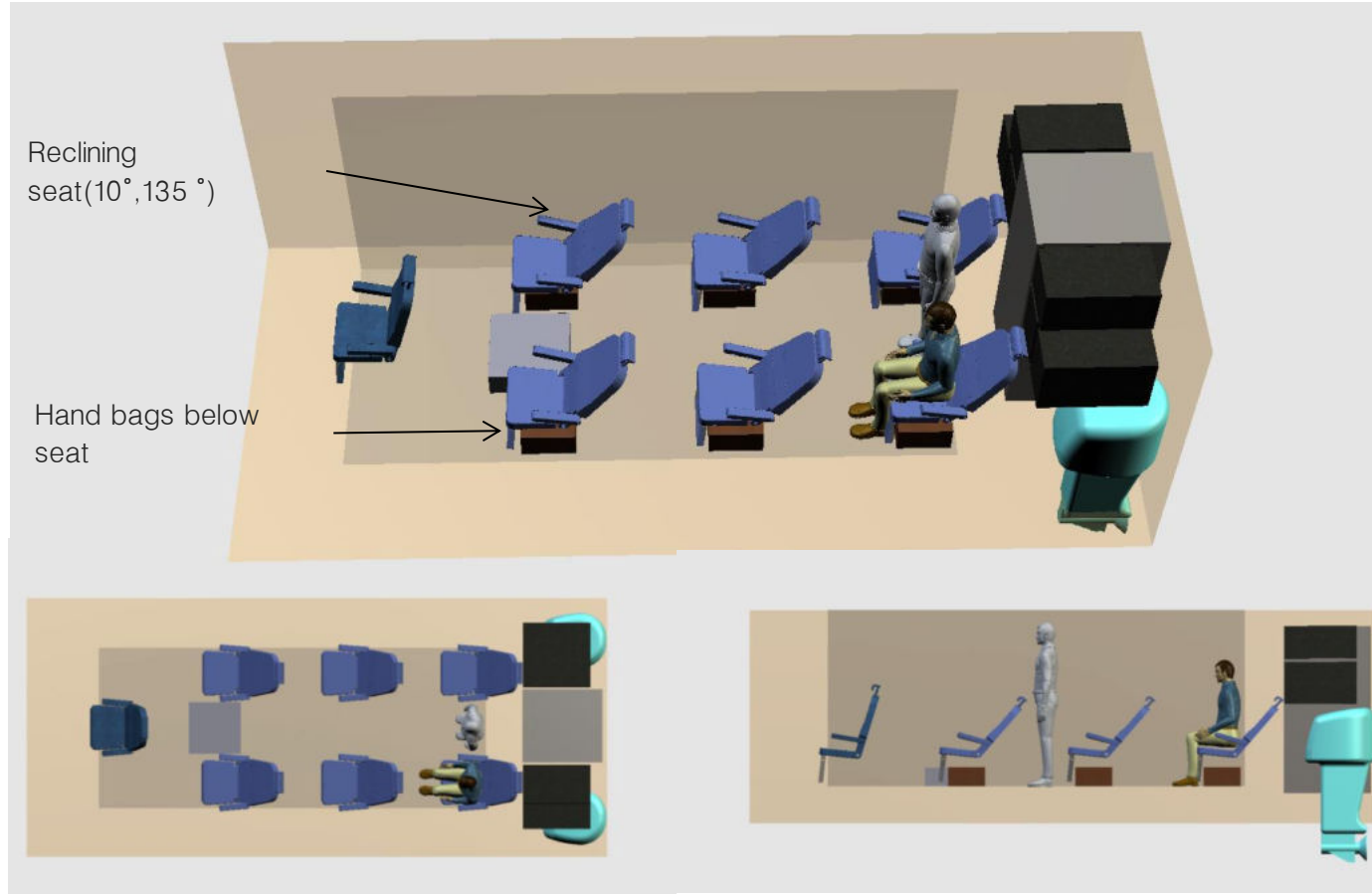

# Concept Development

Alternate luggage arrangement

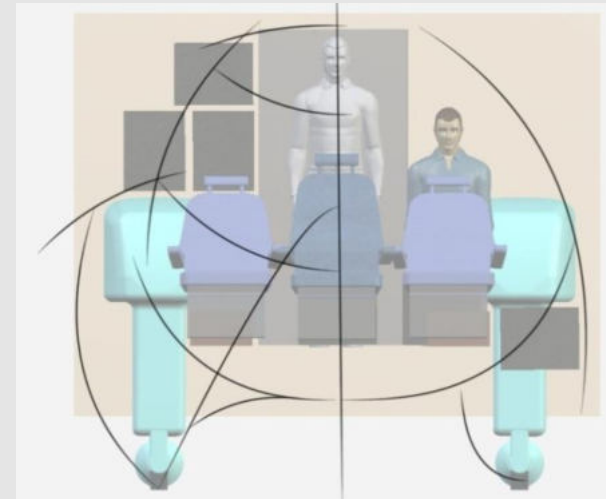
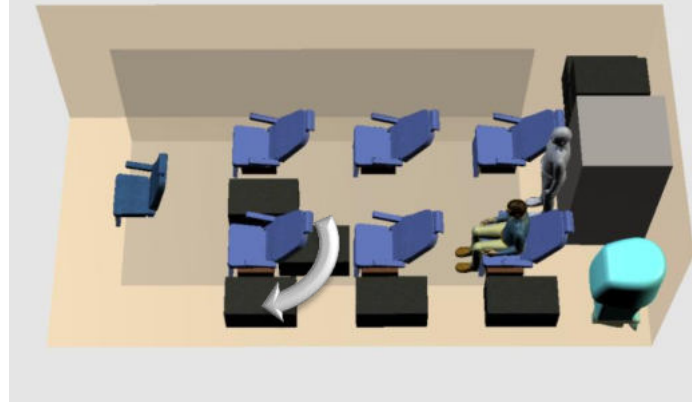
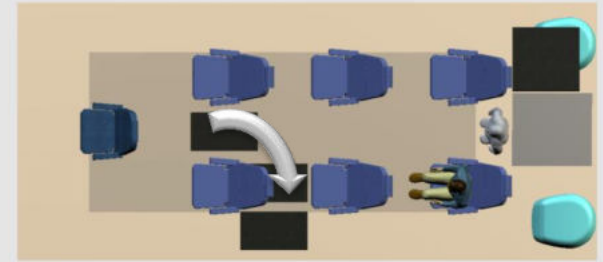
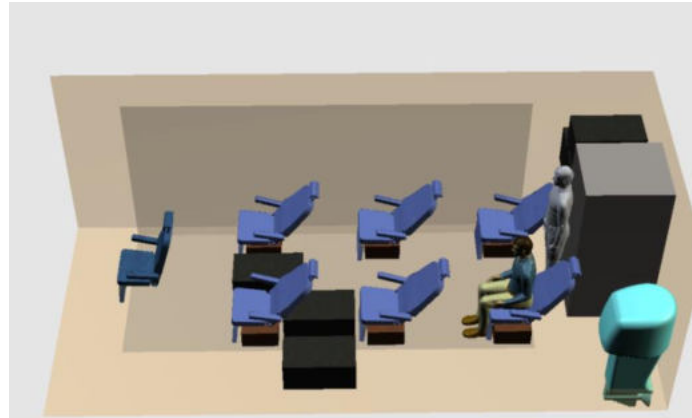

# Concept Development

Braking

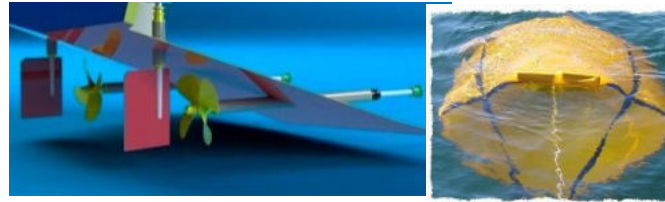

Strong presence of water hyacinth in Kerala inland waterways

Other inspirations for float design



# Concepts (float and propulsion)

## Concept-1

### 2-Outboard IC propulsion

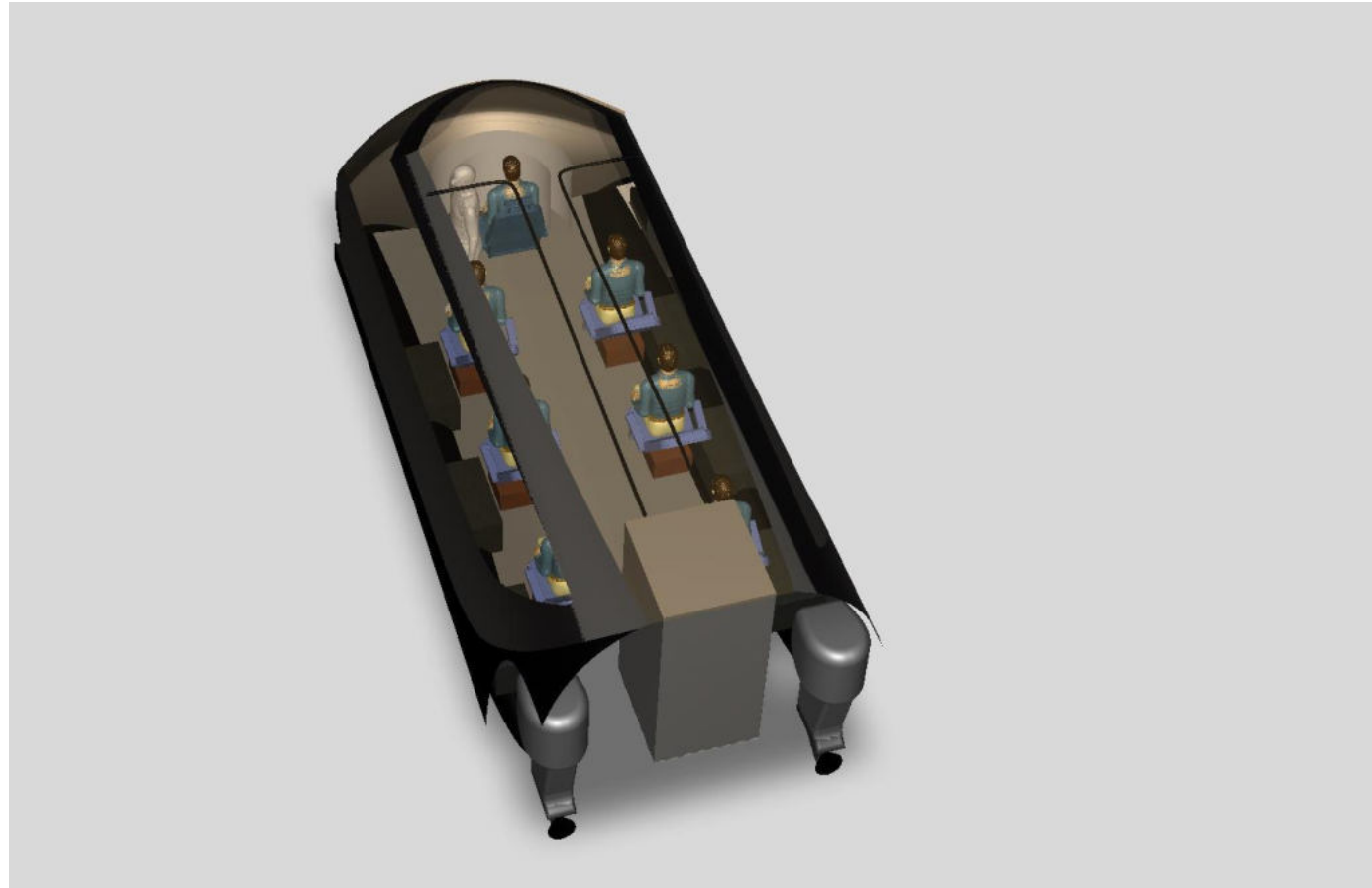

*This concept has two outboard IC engines placed behind each floats. Layout is inspired from conventional catamaran architecture. Each floats can be separately steered to give good handling.*

## Concept-2

Electric propulsion in two floats

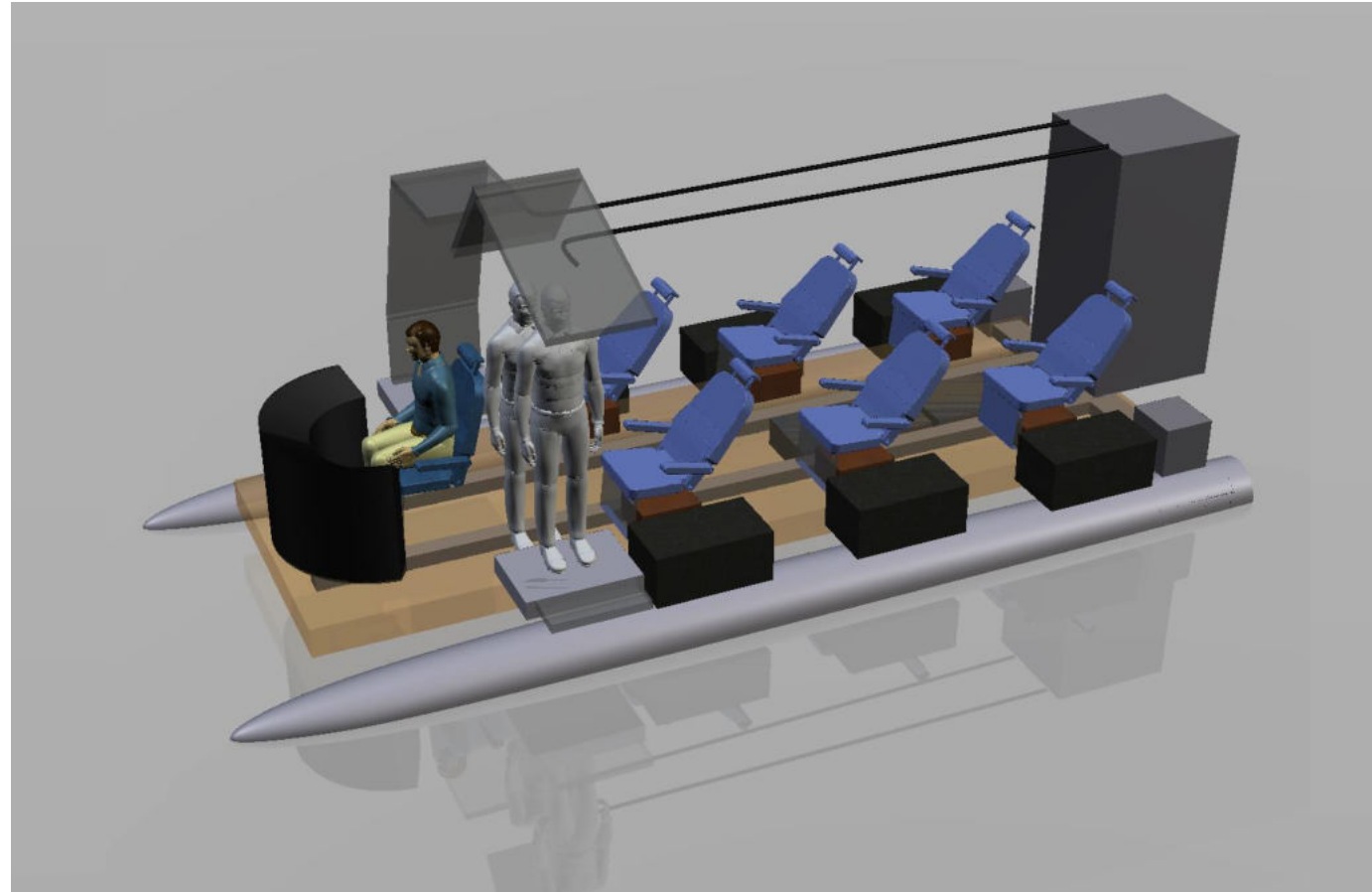

*Concept 2 has two electric motor powering two propeller placed in each floats. The batteries and motors are packed in floats.*

*Reference to this layout is from Planet solar.*

## Concept-3

Hybrid - IC outboard and two electric motors

*This hybrid concept has electric propellers in each floats in addition to single IC outboard at rear. IC outboard provides main thrust. Electric propulsion is considered as auxiliary source. Electric propellers can help when going through narrow sections or during embark and disembark. Charge for electric propulsion can be generated from solar panels place on the roof.*

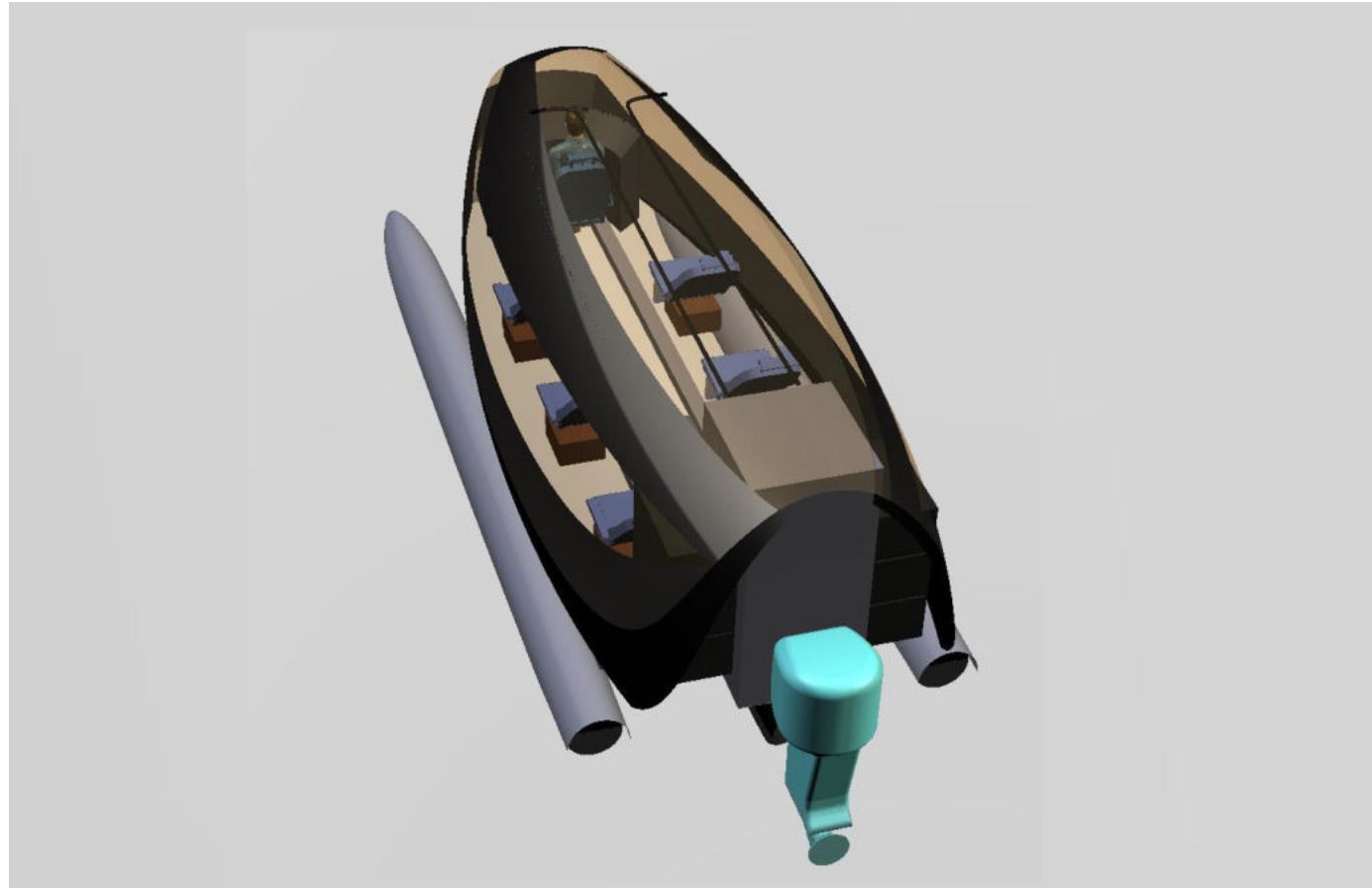

## Concept-3.1

Hybrid - IC outboard and two electric motors

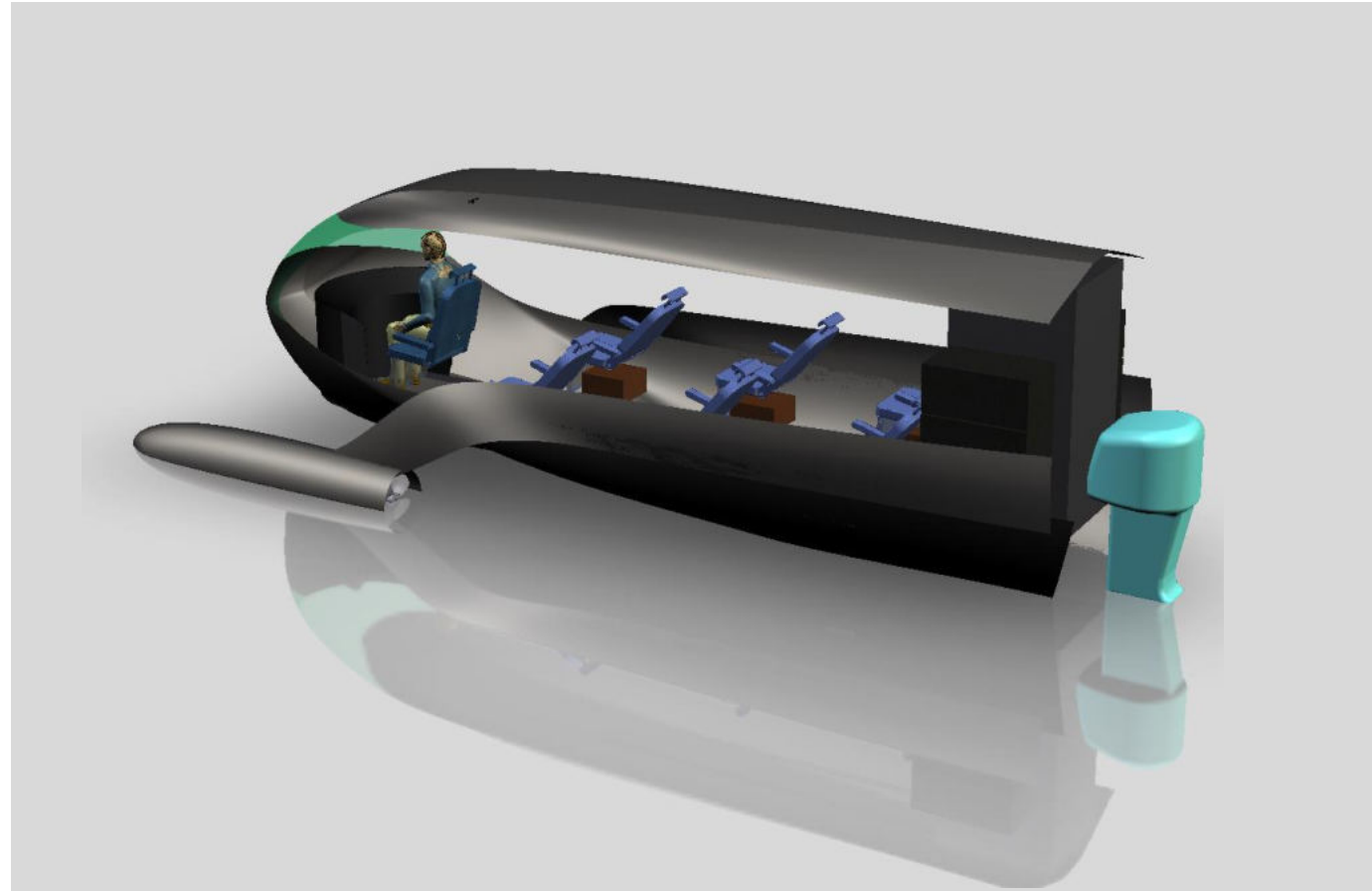

*This hybrid concept has a Trimaran layout.*

*Rear part is similar to monohull boat design, but front has steerable floats with catamaran layout*

## Concept-4

Four electric motors on four floats

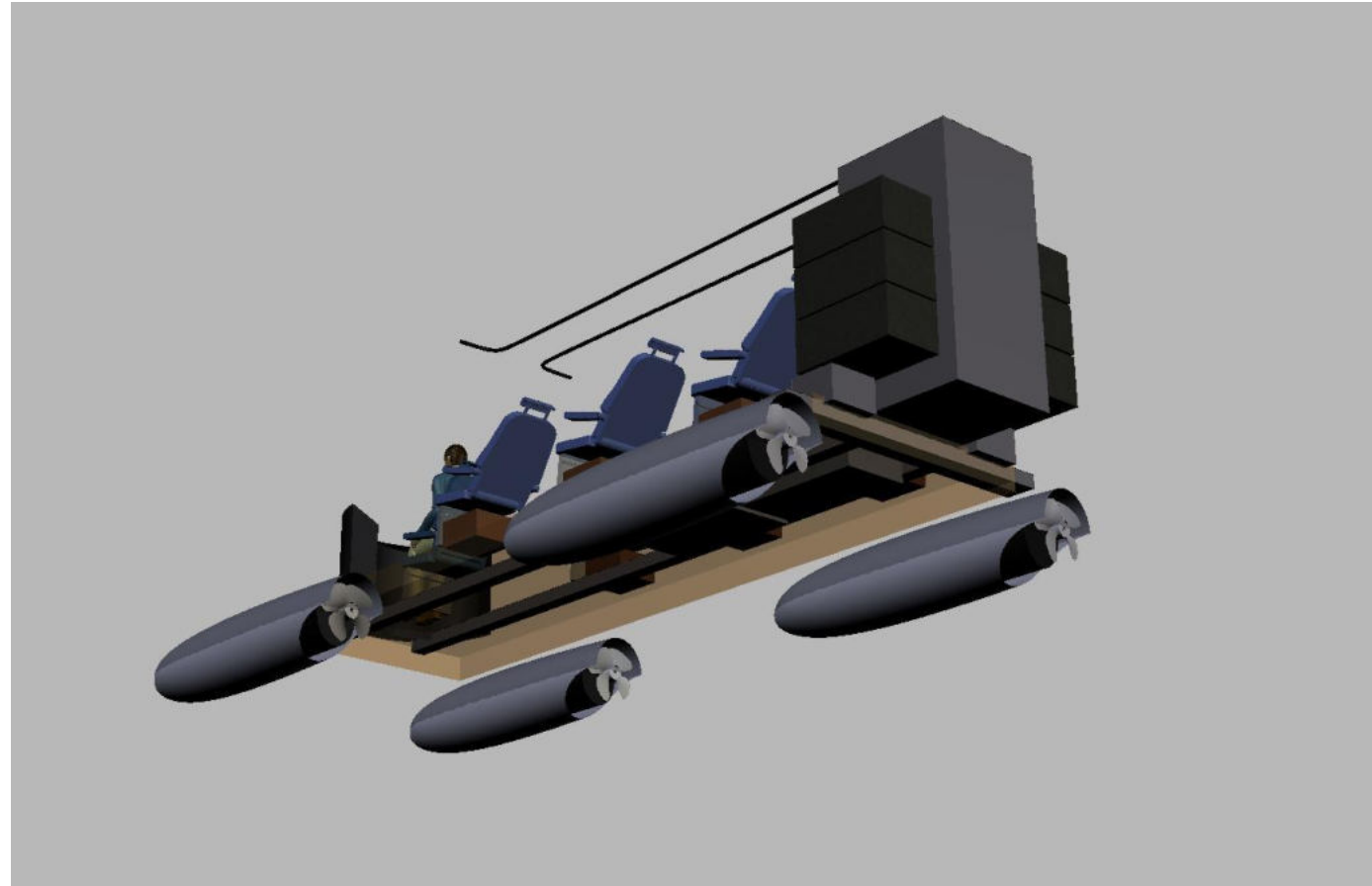

*In concept-4, regular floats of catamaran are replaced with 4 separate floats which can be steered individually. Each float has electric propulsion. These floats helps in better control and braking ability.*

## Concept-4

Four electric motors on four floats

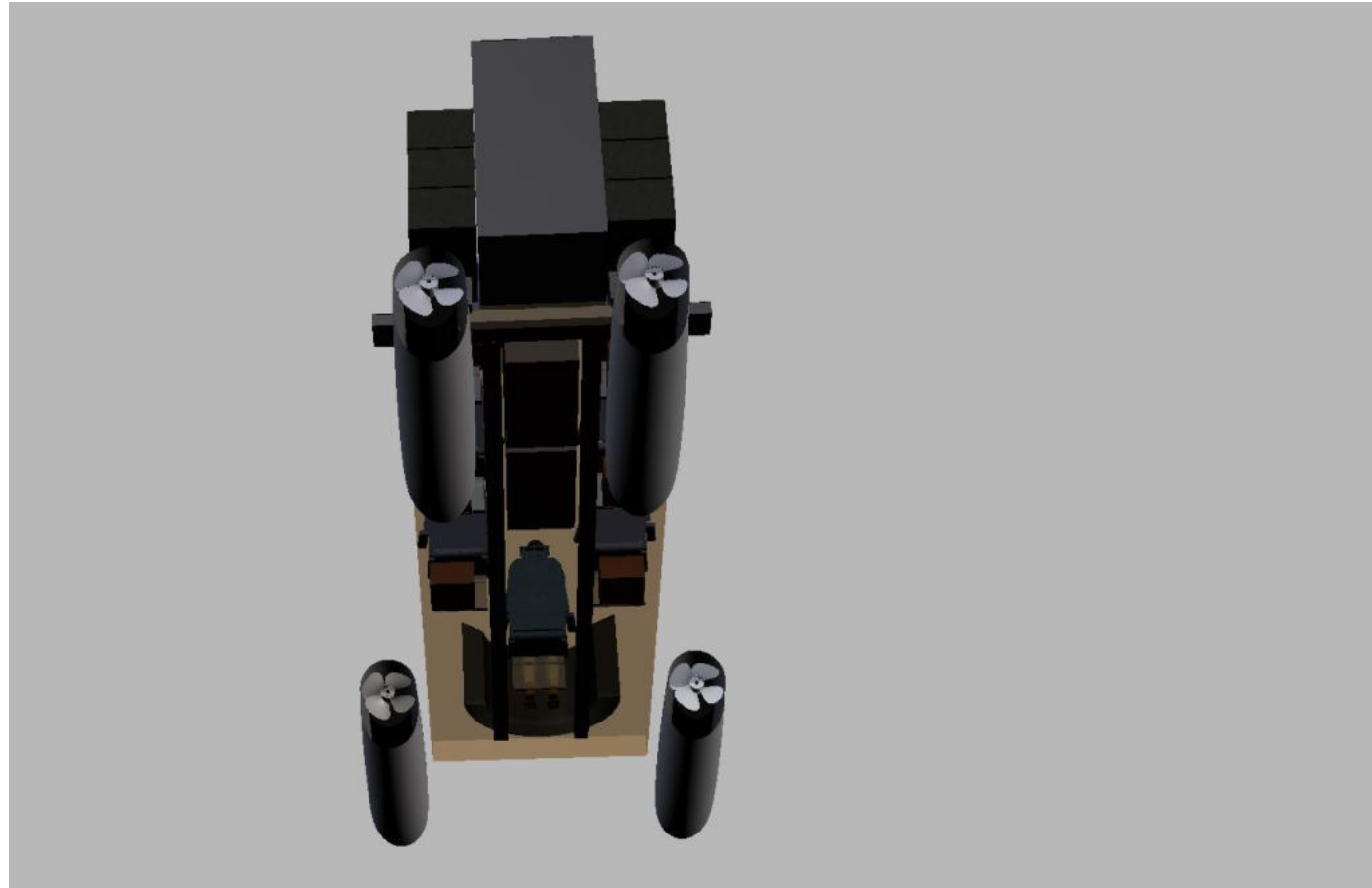

*Variation of concept-4 with rear floats placed near to body to avoid disturbed water from front propellers.*

## Concept-5

Fully flexible float design



*Fully flexible float design with electric propulsion.*

## Concept-5.1

Flexible float design



*Semi flexible float design with electric propulsion.*

# Ideations Interior

Other image inspiration for seating

## Seating

Three scenarios

1. Family
2. Business trips
3. Domestic or international tourists

The seating layout can give a feeling of being connected together. At the same time seating can also be distinct in terms of comfort and personalized feel.



# Seating ideations

model of interior is made.

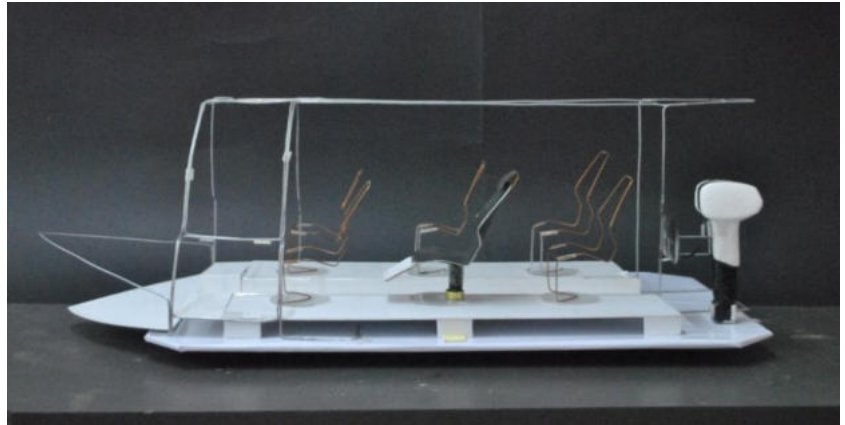
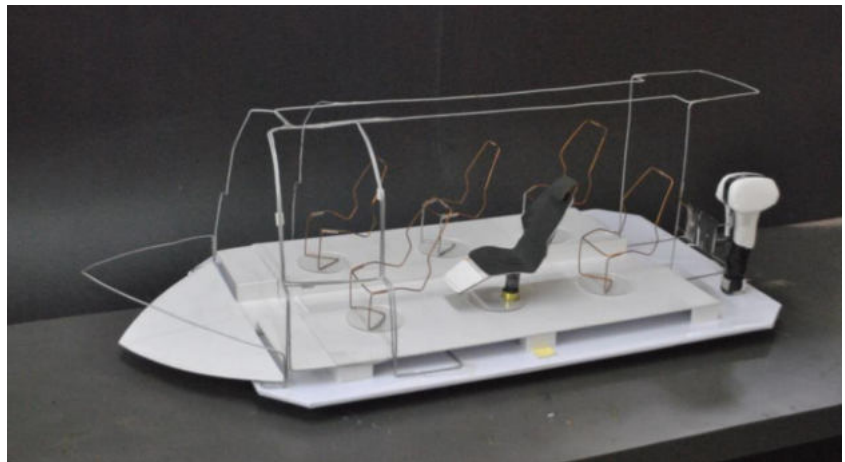
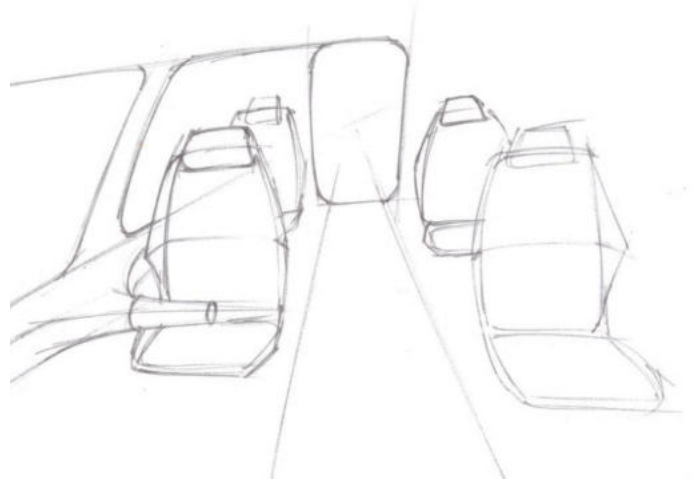
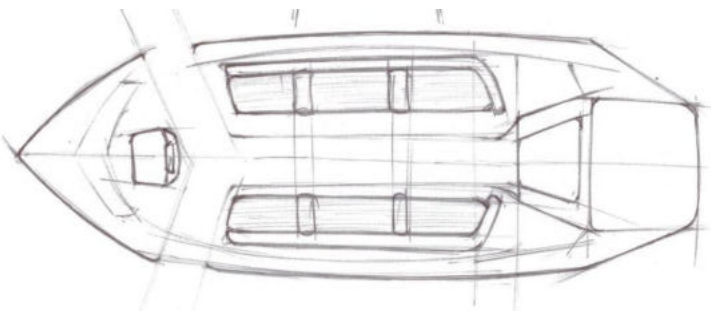

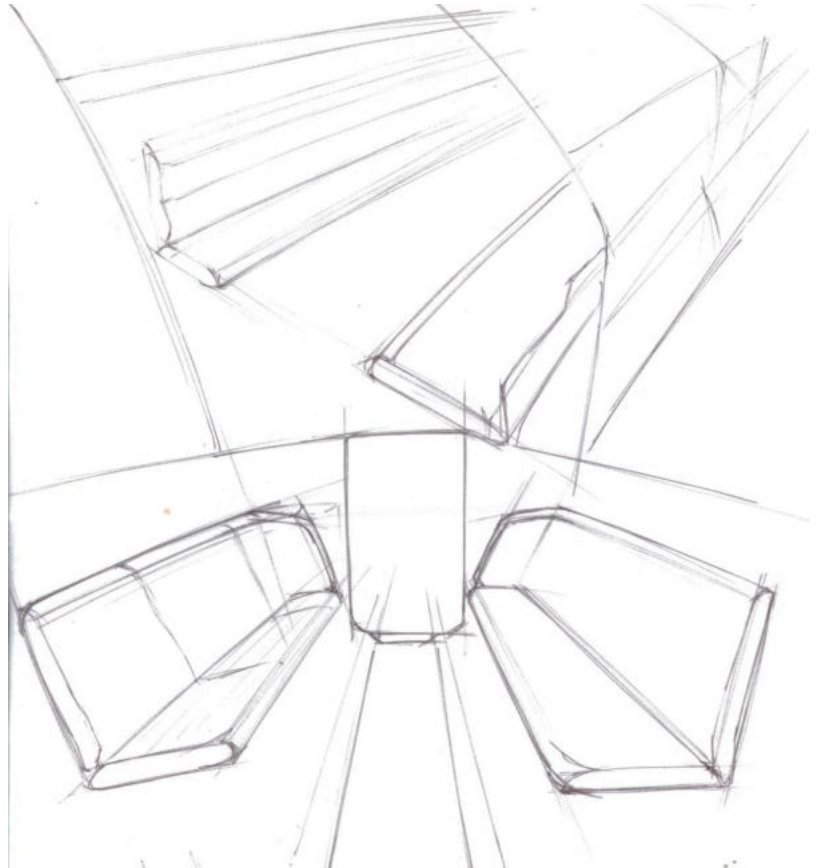
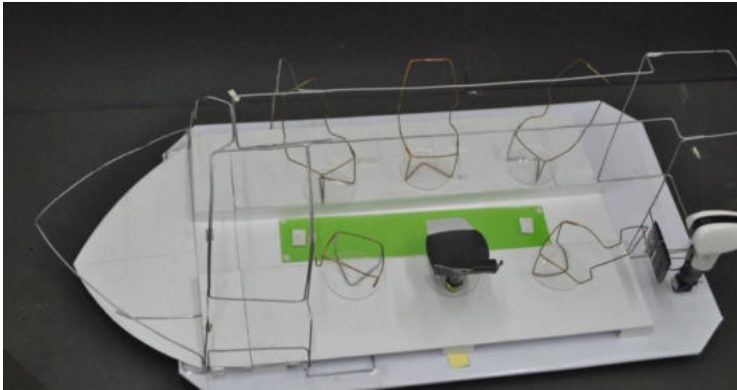

# Door

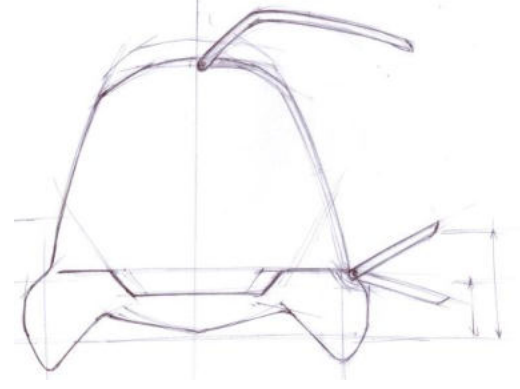
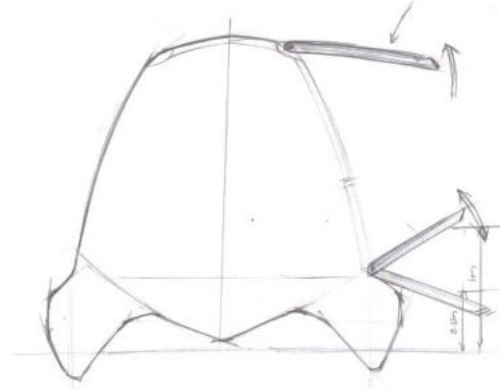
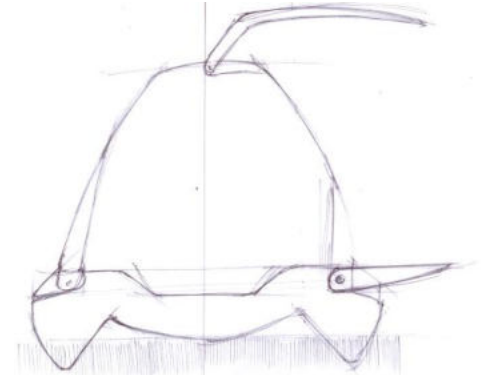
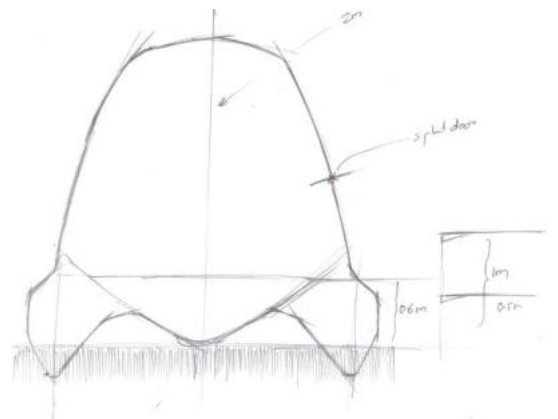
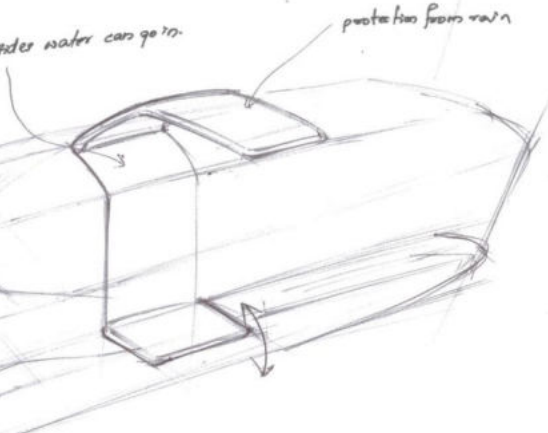

Hand rail.

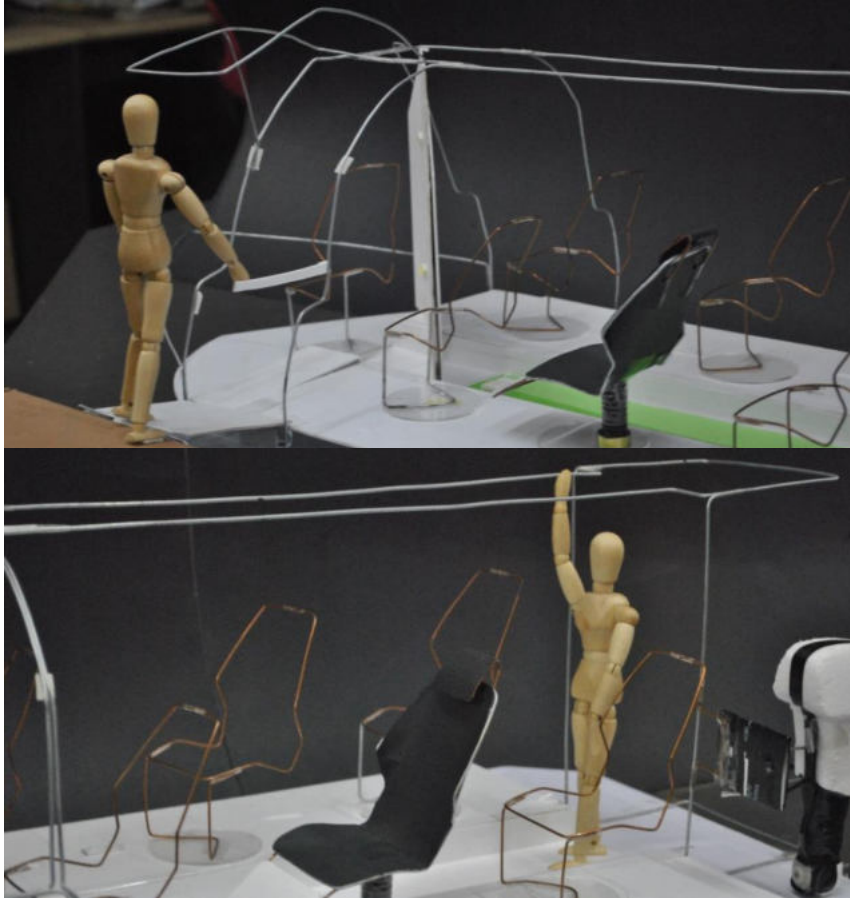
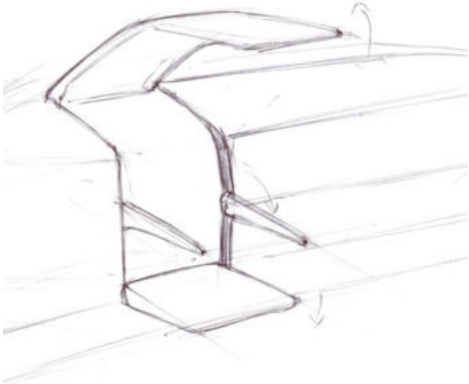

# Cabin isolation and infotainment

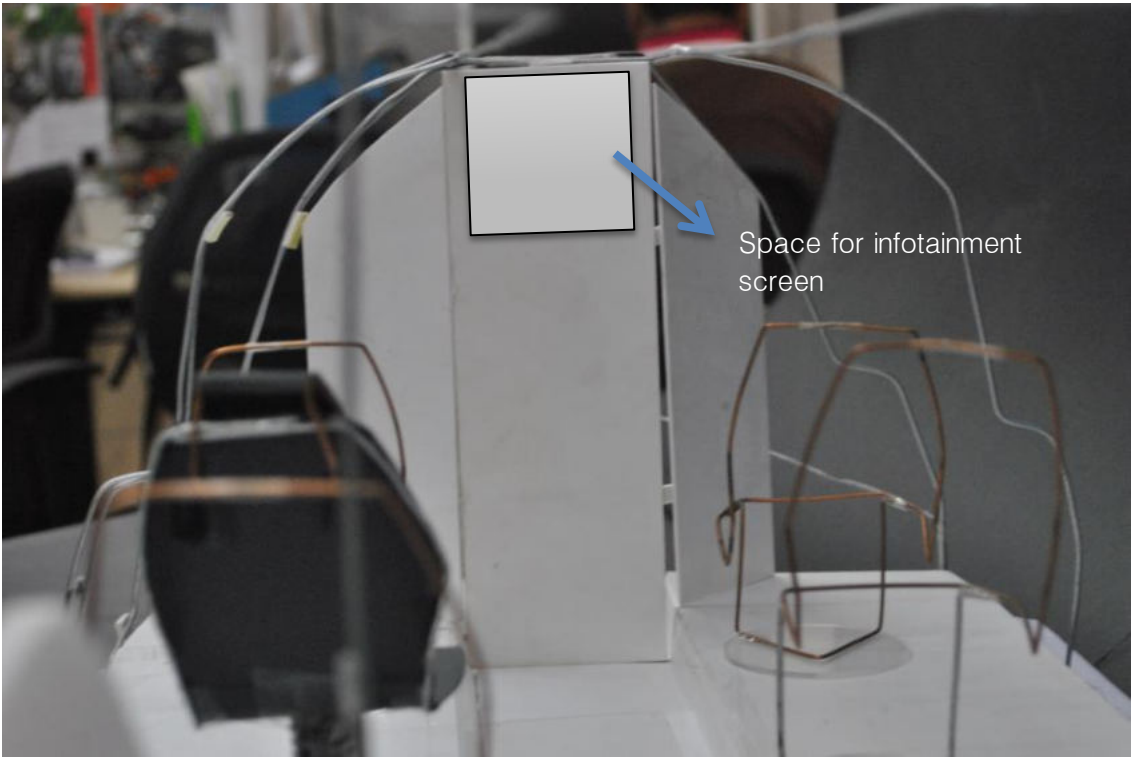
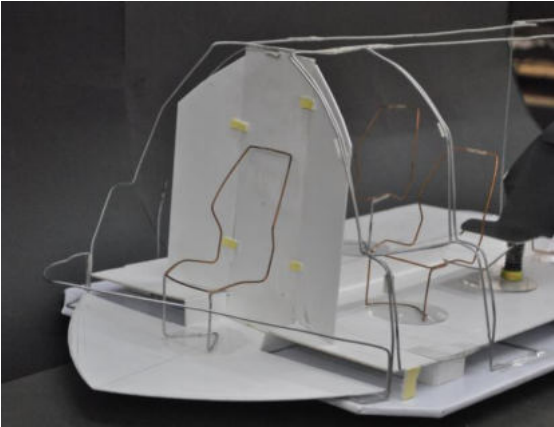
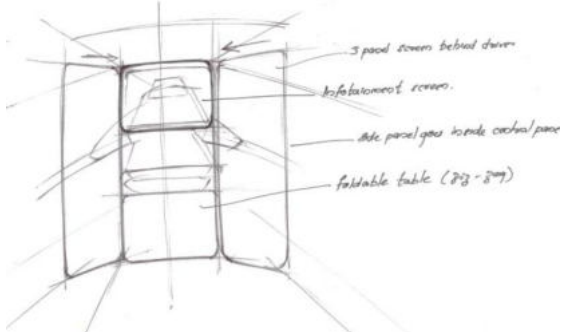

# Driver movement

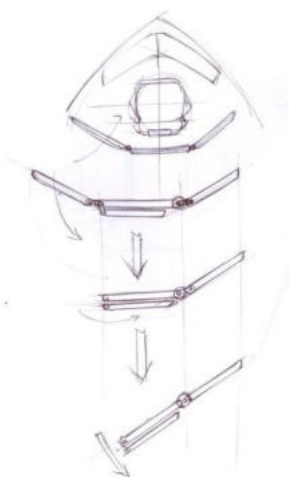

*The pictures shows movement of driver from side door to the cabin. One of the side panel slides/folds into middle panel and the middle panel opens to provide room for driver movement as shown in sketch.*

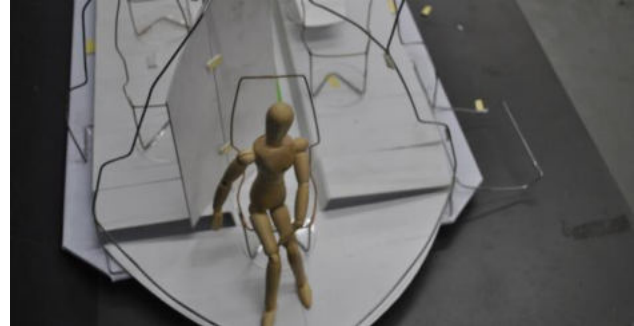
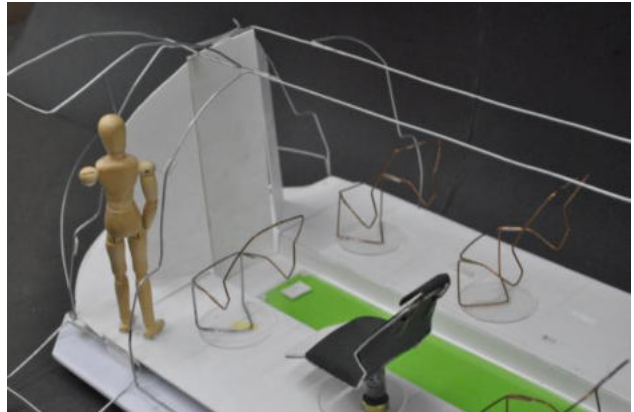

# Interior panels and tray

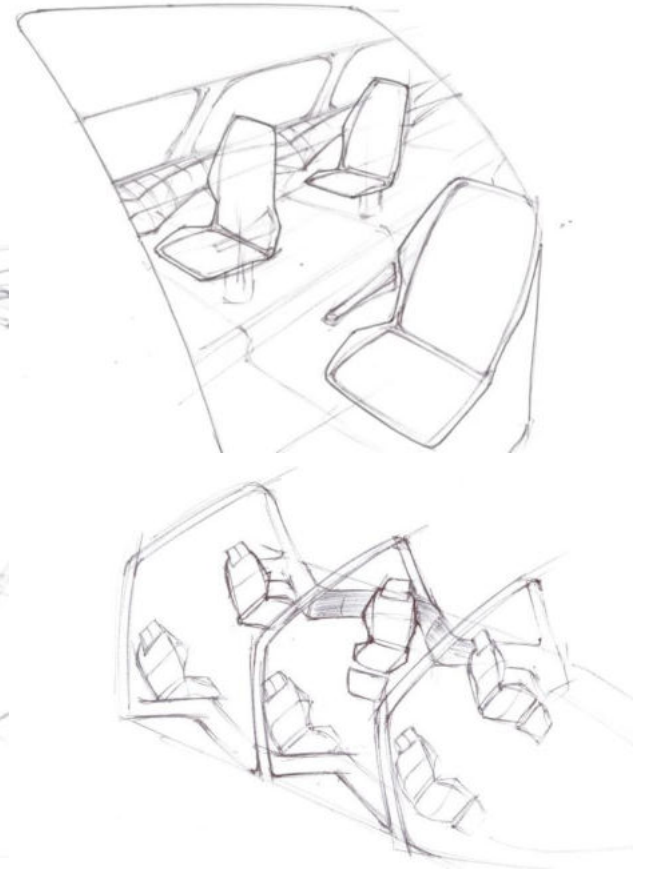
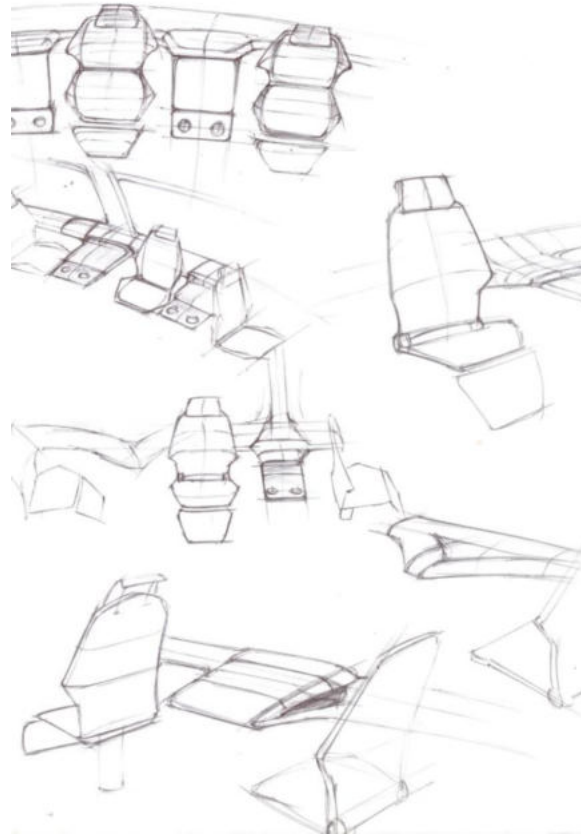
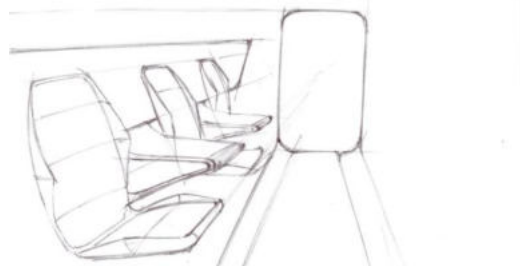
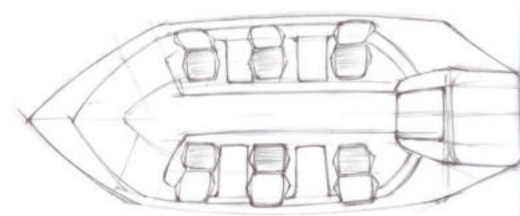

# Seat ideations

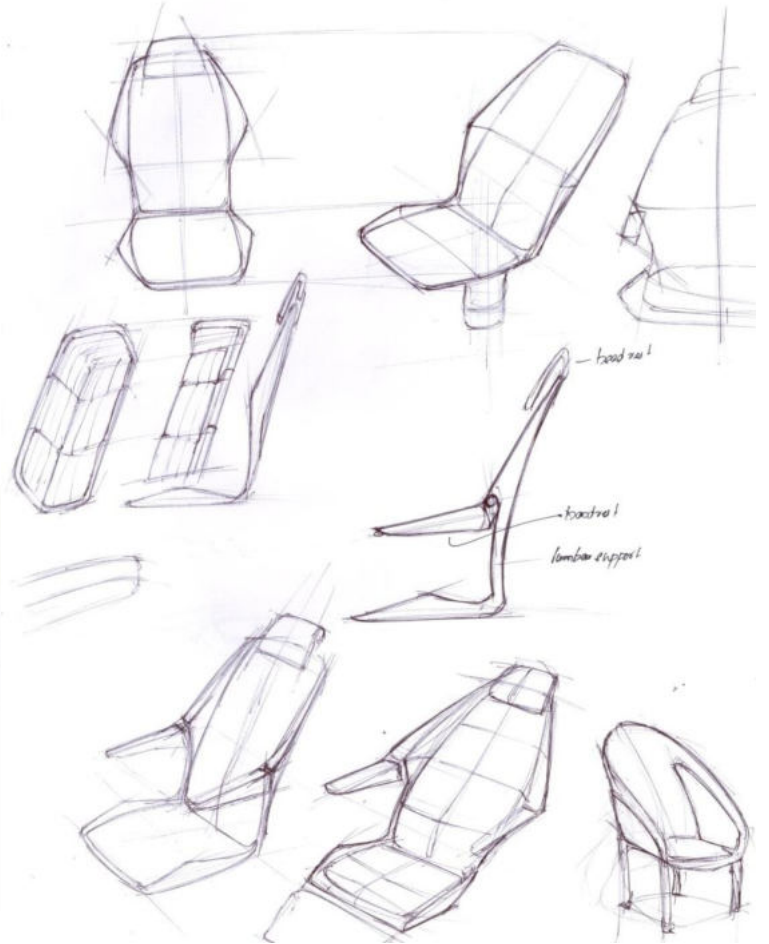
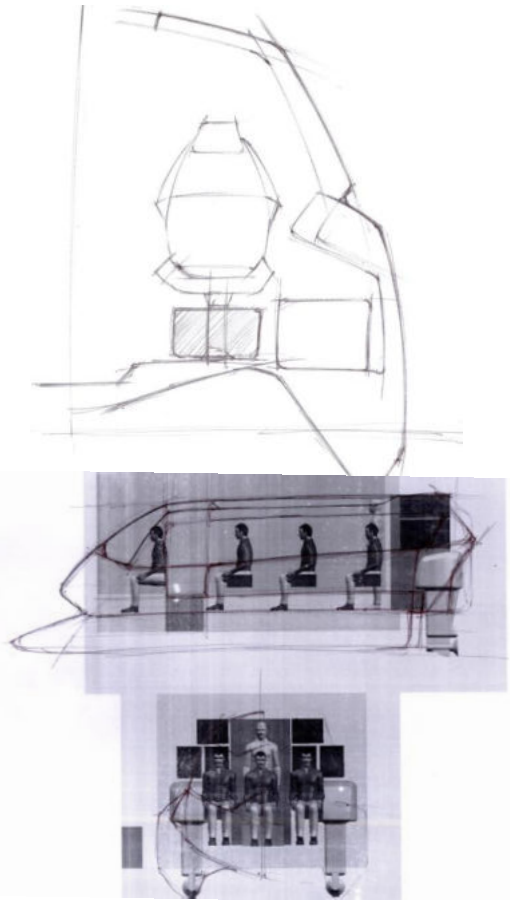

# Ideation in CAD

Seat

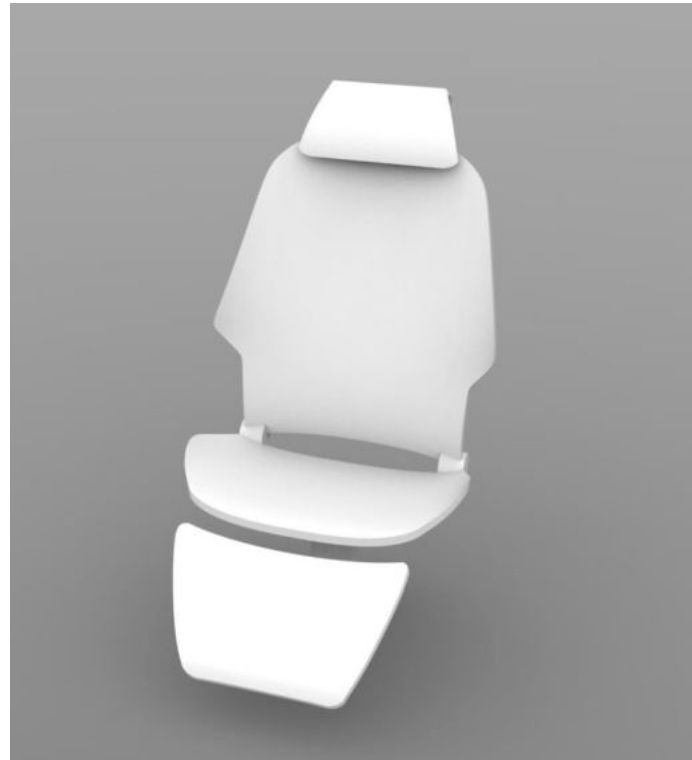

# Seat layout with luggage arrangement

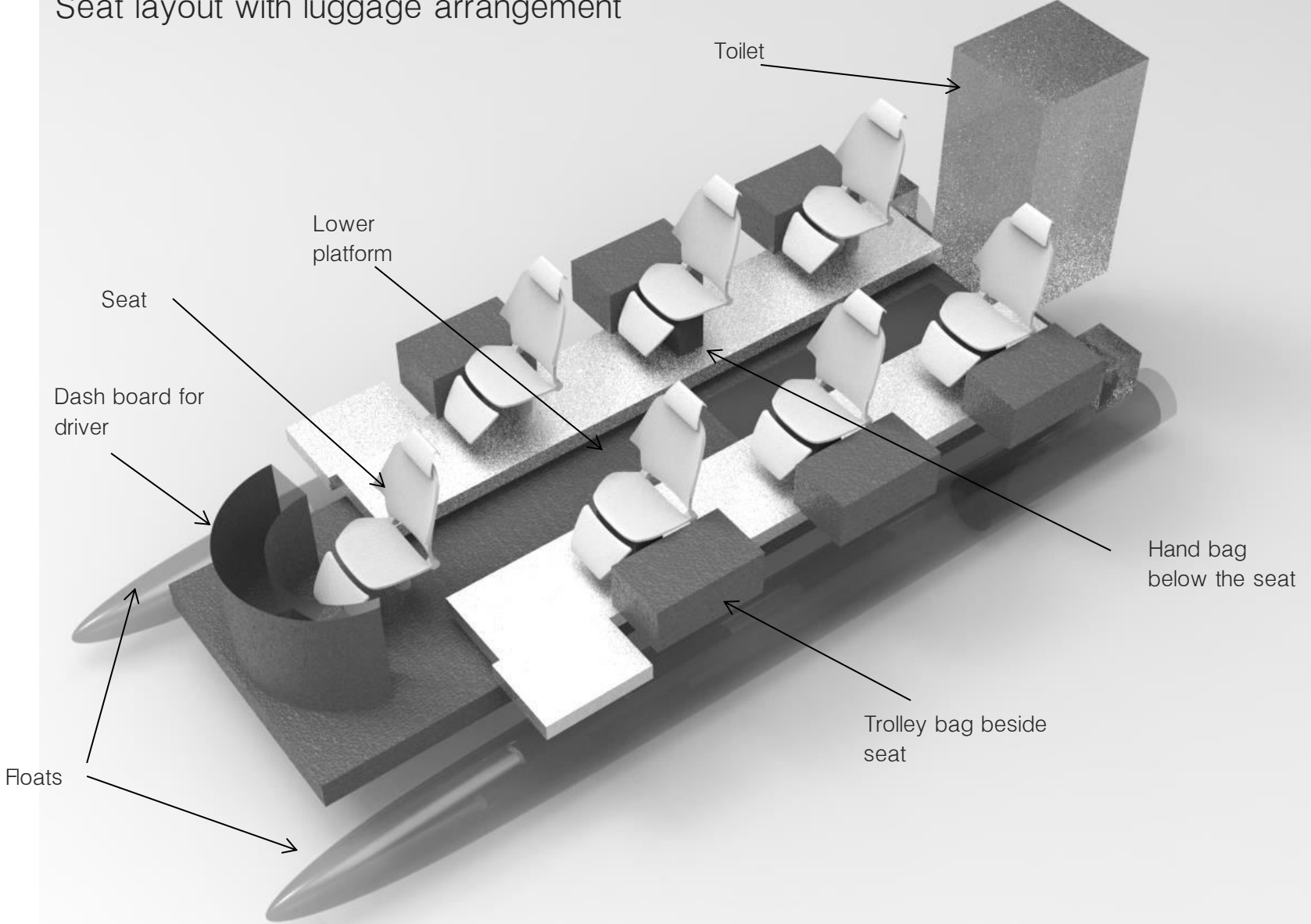

Seating flexibility

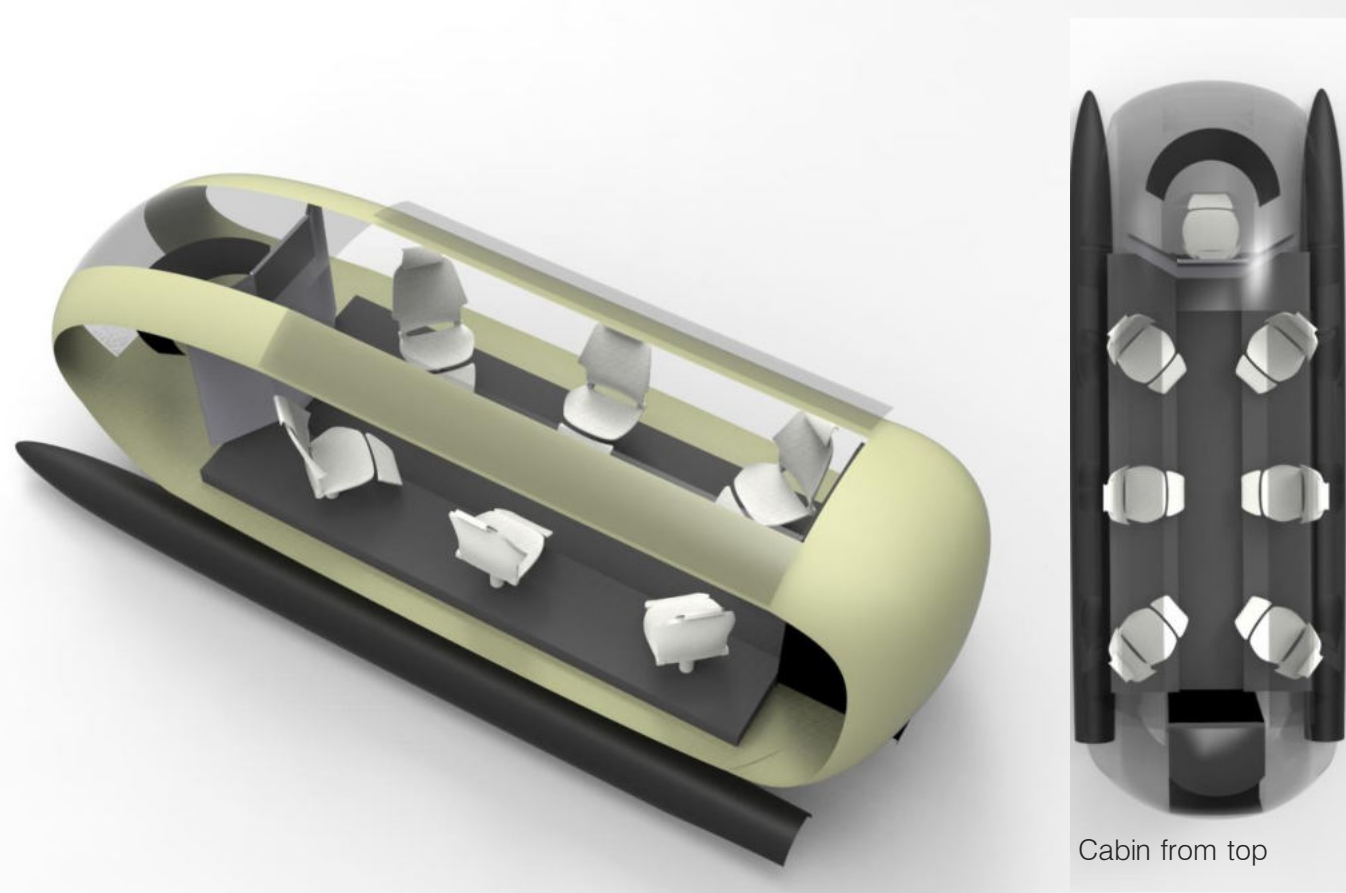

Cabin from top

Defining exterior volume

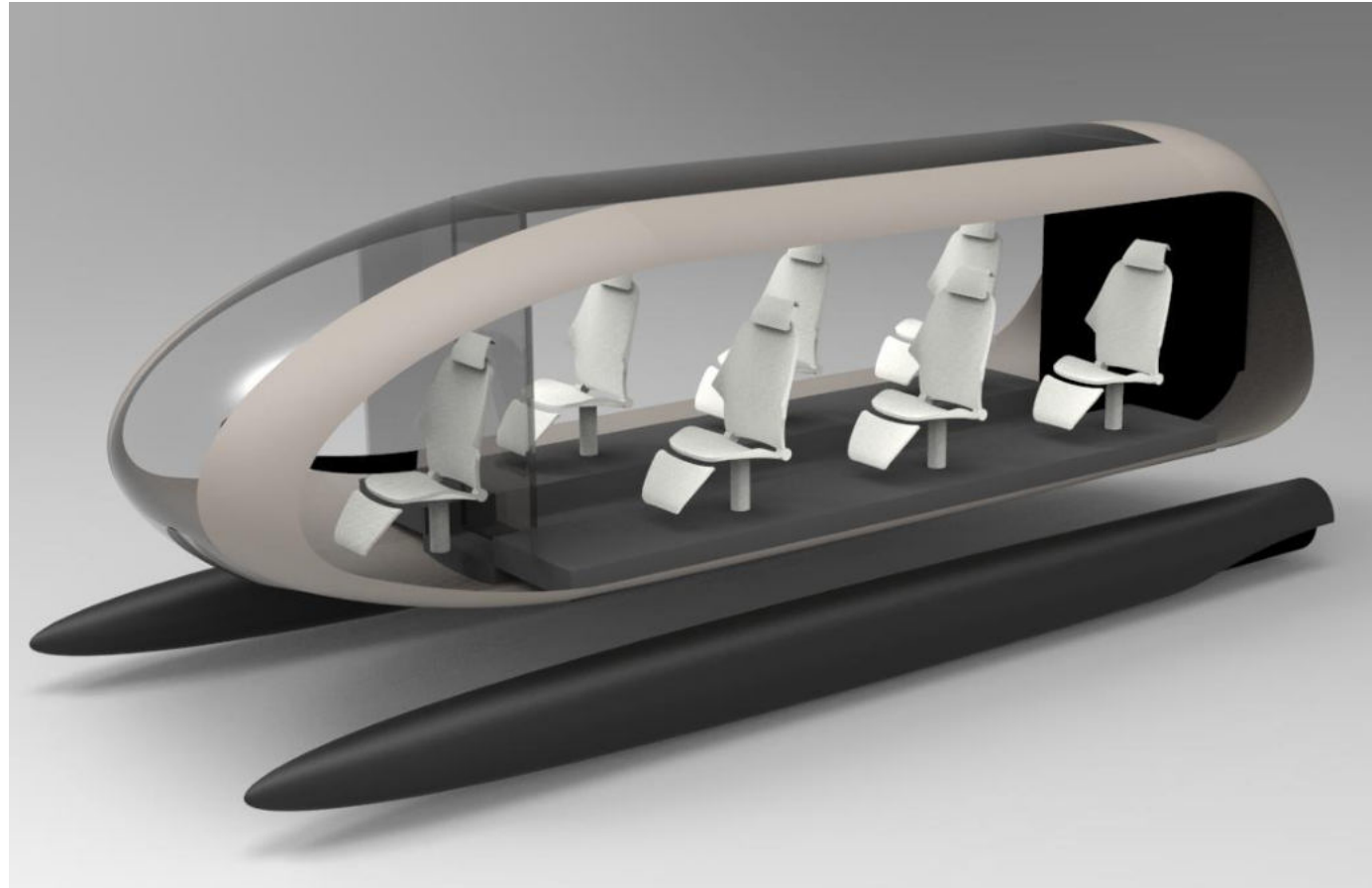

Doors

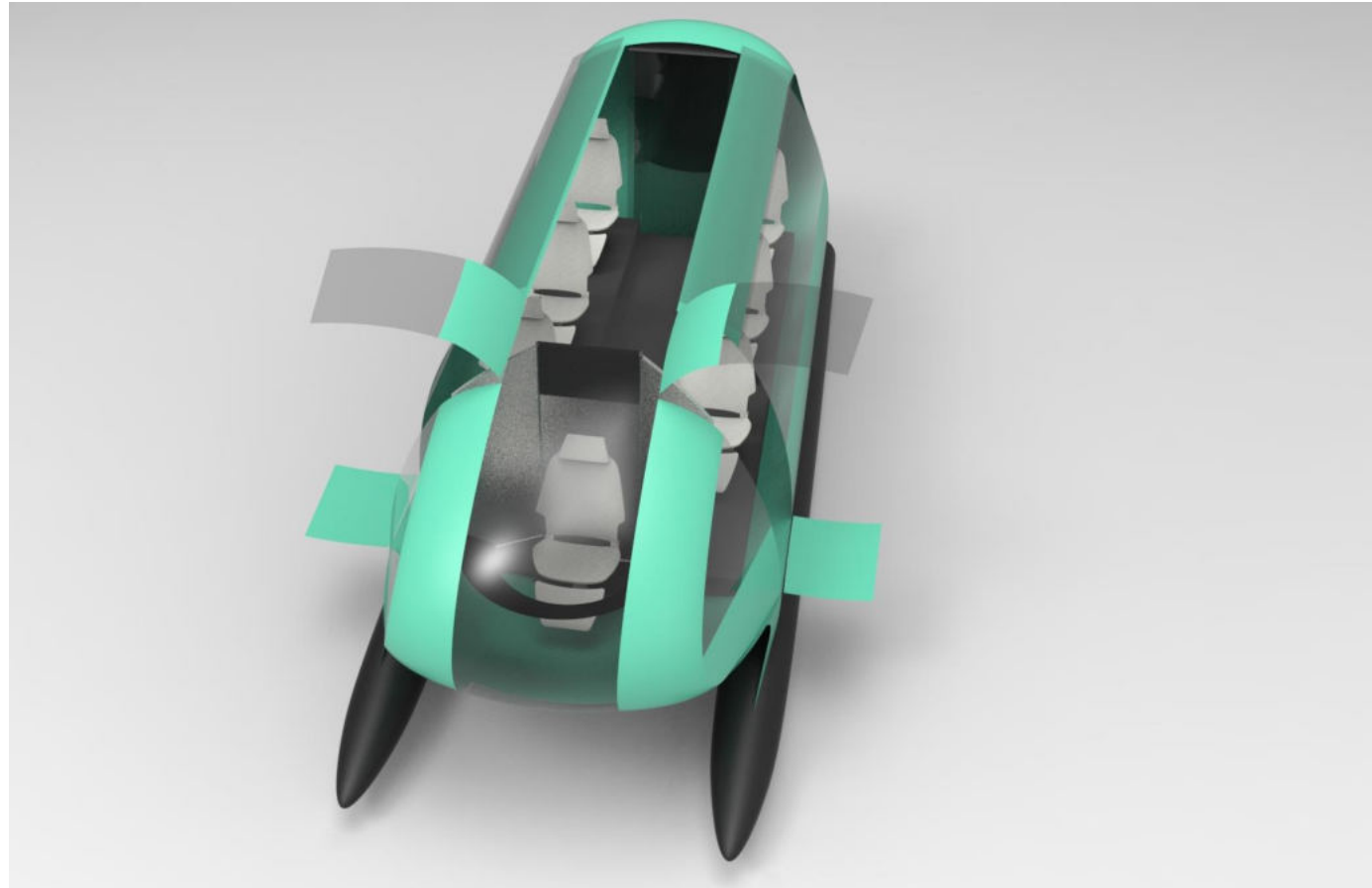

Infotainment



Interior view



Interior

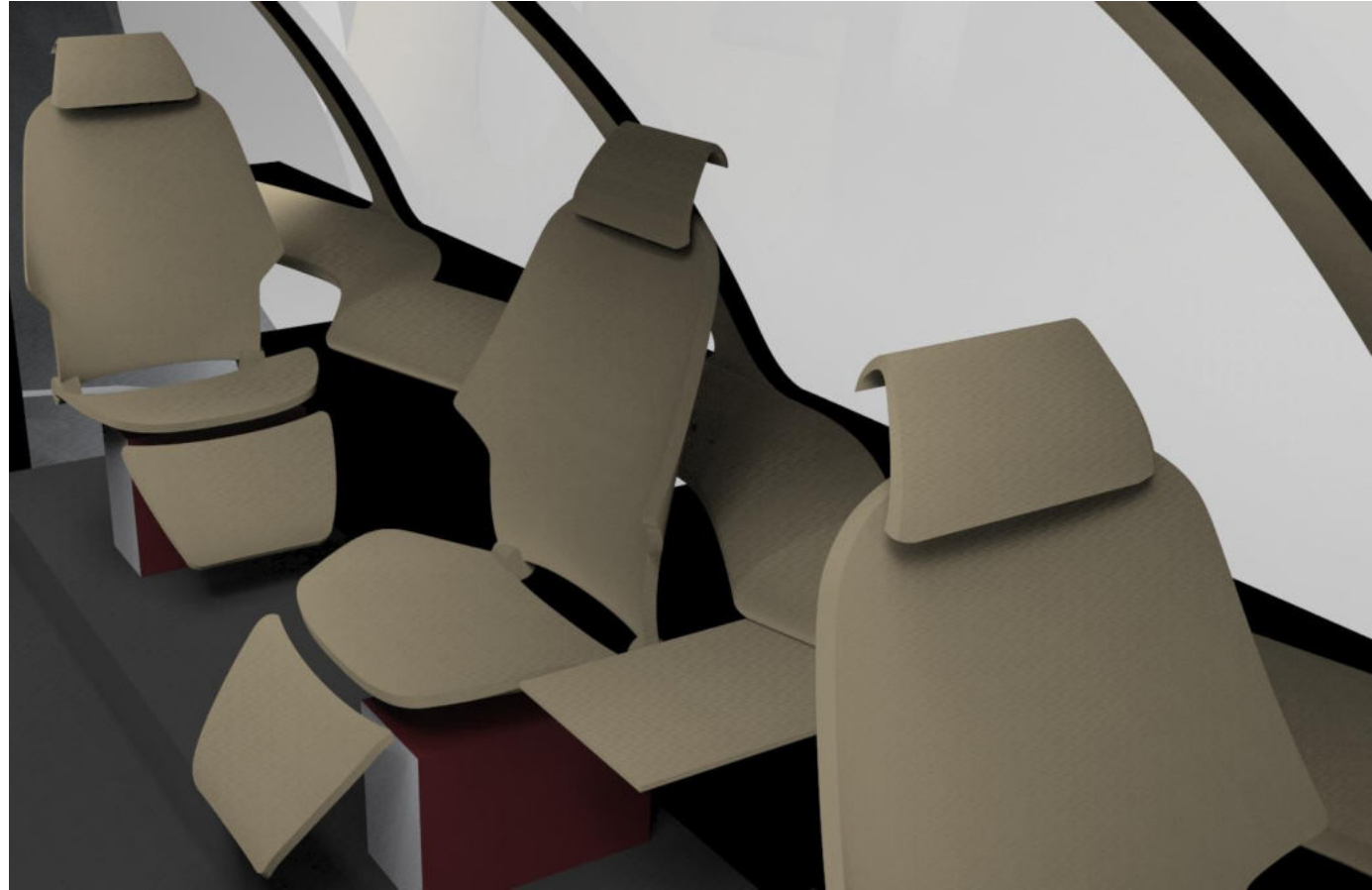

Ideation on frame

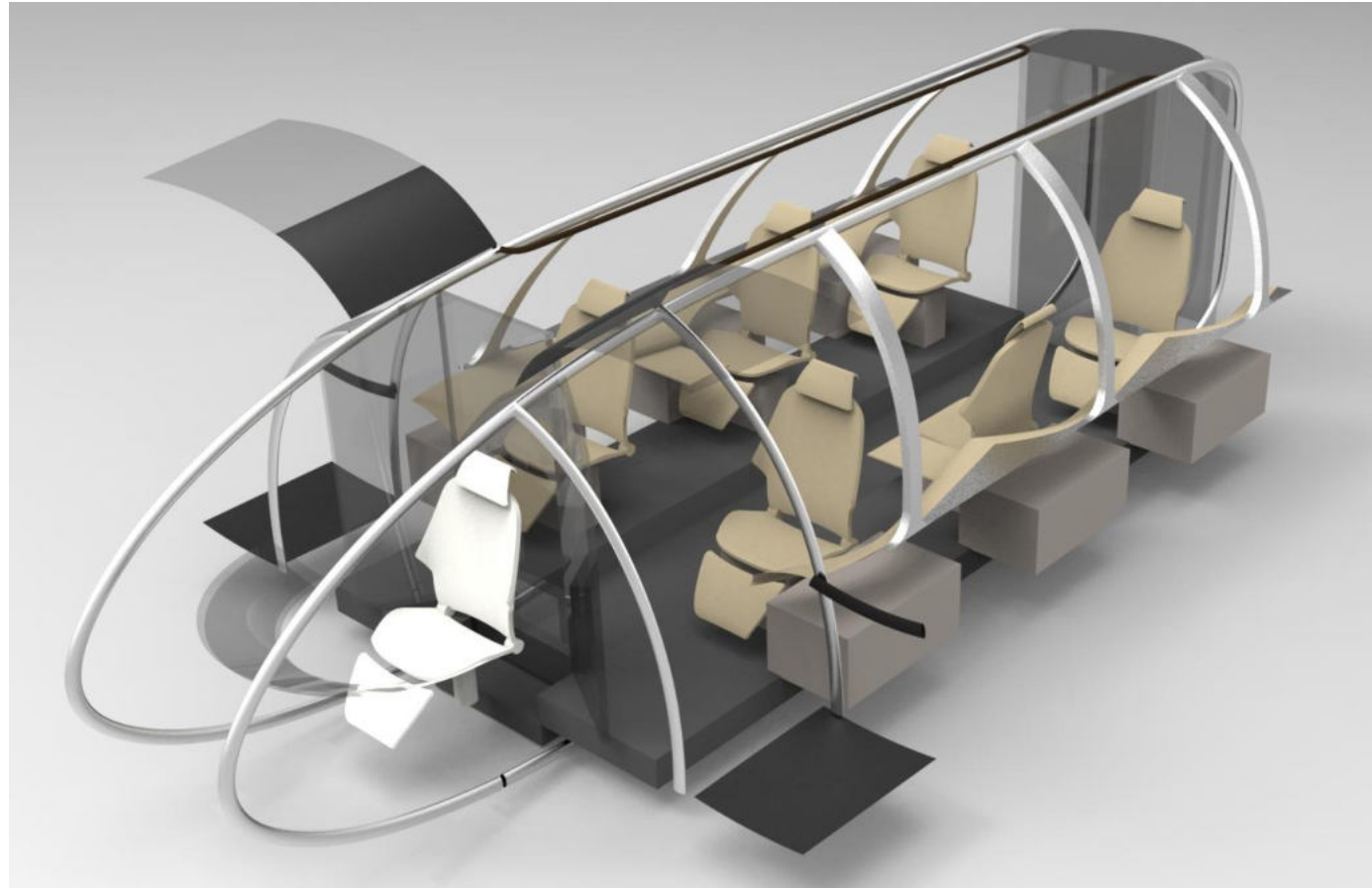

Console in front of seat.

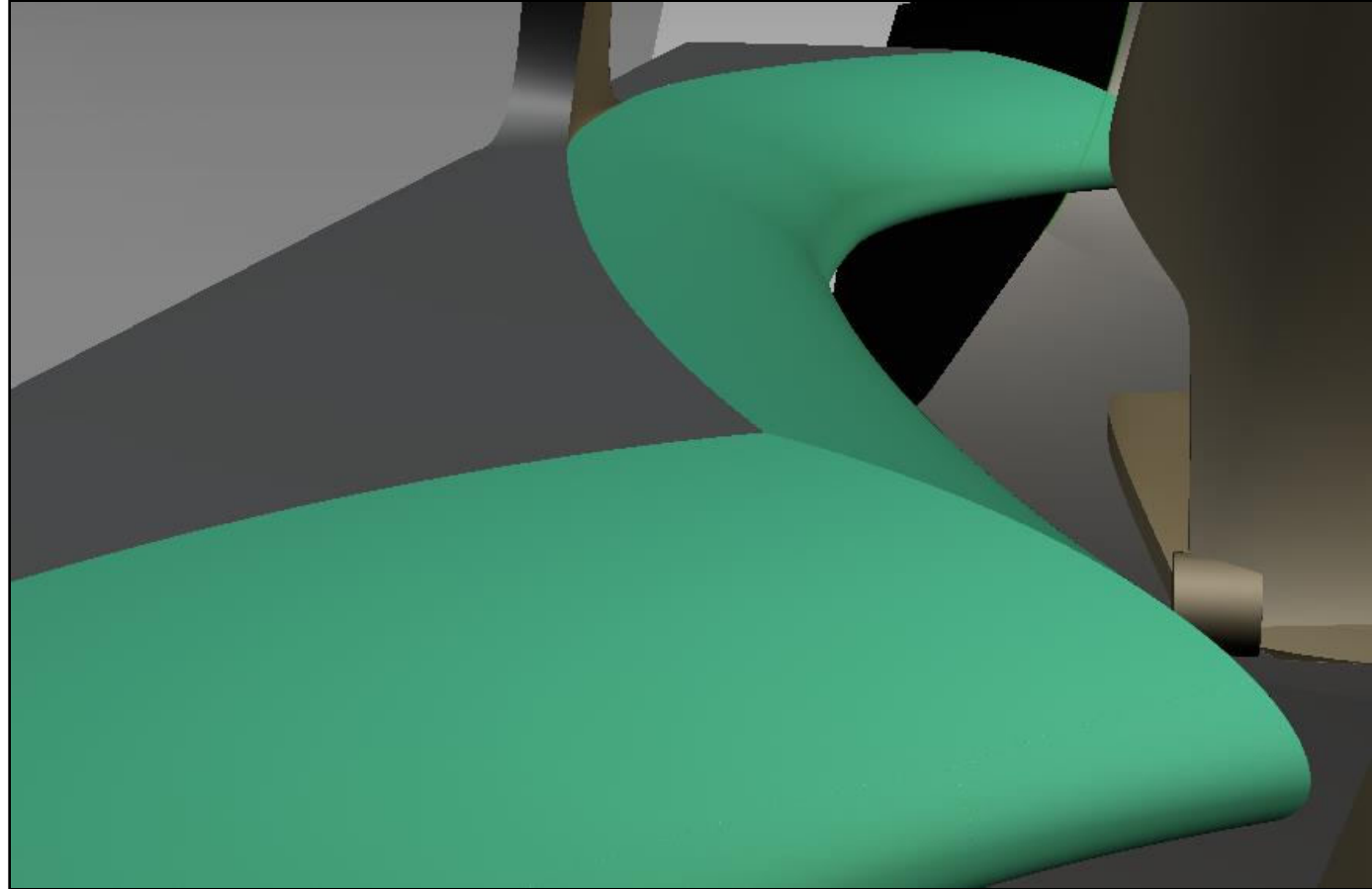

# Design inputs

For better understanding about exterior design Dr. Dileep K Krishnan from ship technology from Cochin University of Science and Technology was approached with works till date. Professor was kind enough to spent good quality time on discussions and feedback.

Route constraints NW-3

Catamaran Floats can be

- Normal semi submersible floats
- Fully submersed floats

Hull Materials

Current materials of choice

- Steel
- Aluminum
- FRP
- Wood

Weight of the catamaran.

With a seating capacity of 7 persons ,passenger weight comes around **525kg**.

- Luggage taken around 27kg(20kg(trolley bag)+7kg(hand bag)),bringing total luggage weight to **189Kg**.
- Outboard engine weight for 115hp comes at190Kg.With two engines total engine weight comes to **380Kg**.

Total weight of boat= Occupants+ luggage +Engine + Support systems + Material weight of catamaran.

Support system includes AC compressor, batteries and water storage for toilet.

Material weight of Catamaran= Float+ super structure + Interior

Approximate factor for FRP shell weight is 13kg per sq.m

FRP body requires stiffeners, which will add 40% to FRP body weight.

## Resistance.

- Frictional resistance
- Residual resistance

Residual resistance is the sum of all other resistances of which wave-making, form, and yaw are the most important.

## Why weight is so critical

While road vehicle has to overcome rolling resistance and air drag, boat required energy mostly for

- getting forward thrust from water ,
- also to generate waves

Wave generation is an undesirable character of boat movement. Wave strength increases with ratio of length and breadth of immersed portion of boat. Normally in Catamaran design this ratio is small due to two narrow floats.

Volume and surface area

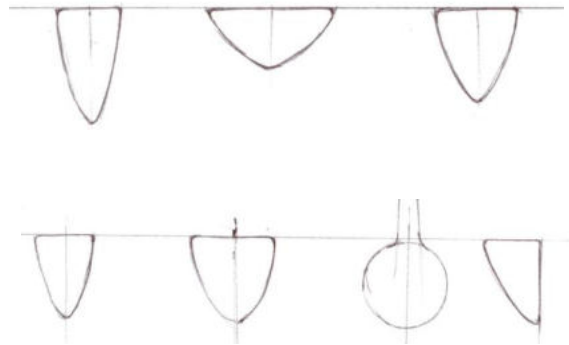

Cross section for float

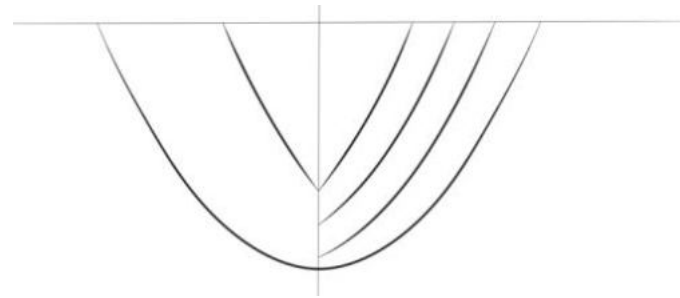

Transition of cross section

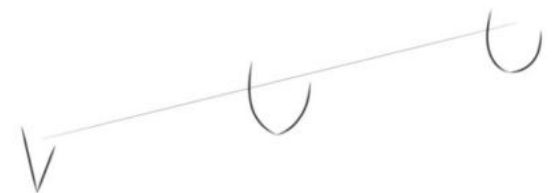

# Evaluation

Internal combustion engine	Electric propulsion
Polluting in nature	Clean source of power
Output from combined weight of engine and fuel is higher	Output from combined weight of electric motor and batteries is less.
Low initial investment	High initial investment
High running and maintenance costs.	Low running and maintenance costs.
Refill is possible almost every where enabling a long range	Limited range
Low end torque is less	Better low end performance

Though electric propulsion has been successful in many examples around the world, IC outboard makes more sense as the source of propulsion in long distance water taxi.

Catamaran design with twin propeller behind each floats enable it to do a 360 turn in its own length. This advantage with the architecture does not demand for further experiments on float design.

For this project rigid float design is selected for design explorations, though flexible designs on float seems to have practical potential.

# Concept selection

IC out board



Hybrid Single IC and two electric motors on floats

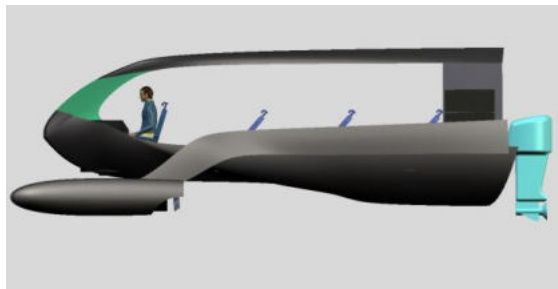

Pure electric with rigid floats



Electric outboard with flexible floats



Electric with split floats

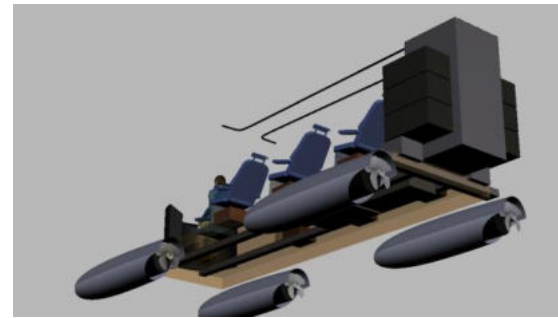

# Concept detailing

## Float designs selection

Catamaran with two outboard IC engines

Semi submersed floats

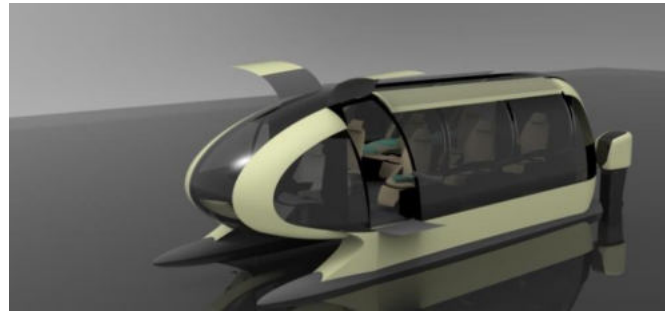

Fully submersed floats

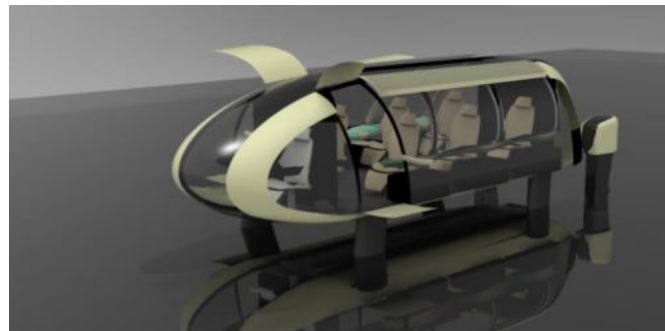

Evaluation-Peer review

Semi submersed floats

- Stable feel
- Looks complete and aggressive.
- Feels like floating.
- Safe and balanced with larger surface area on side.

Fully submersed floats

- About to topple down.
- Lacks stability.
- Feels static.
- No floating feel.

# Native Inspirations

Chundan vallam

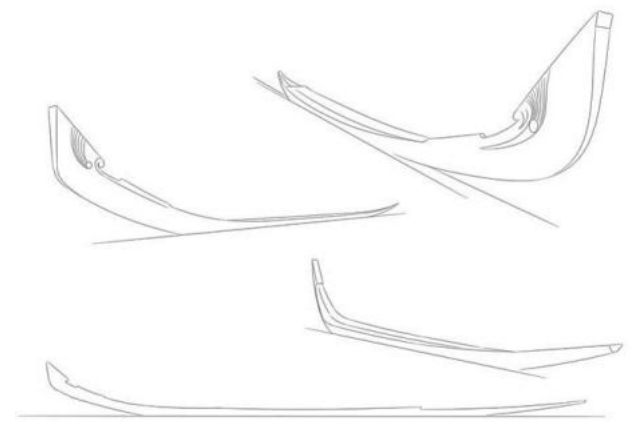

Kettuvallam

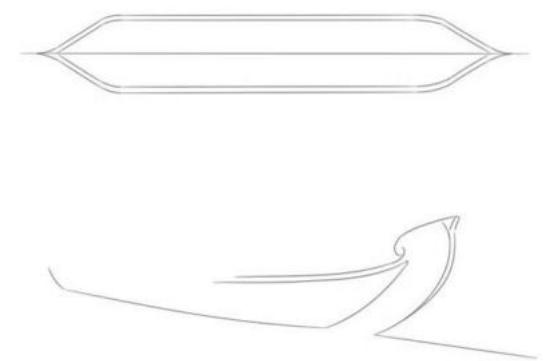

# Silhouette explorations

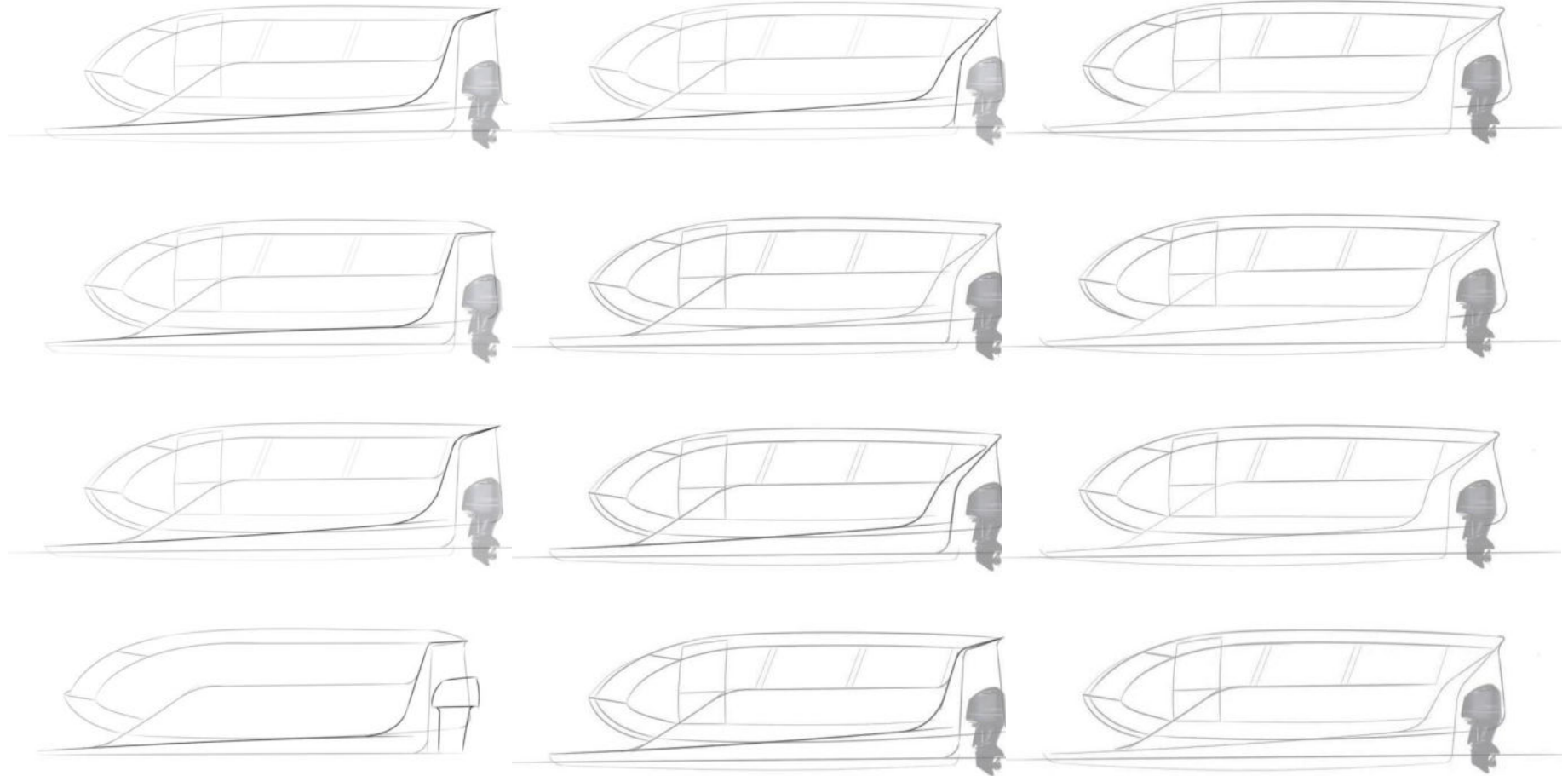

# Silhouette explorations

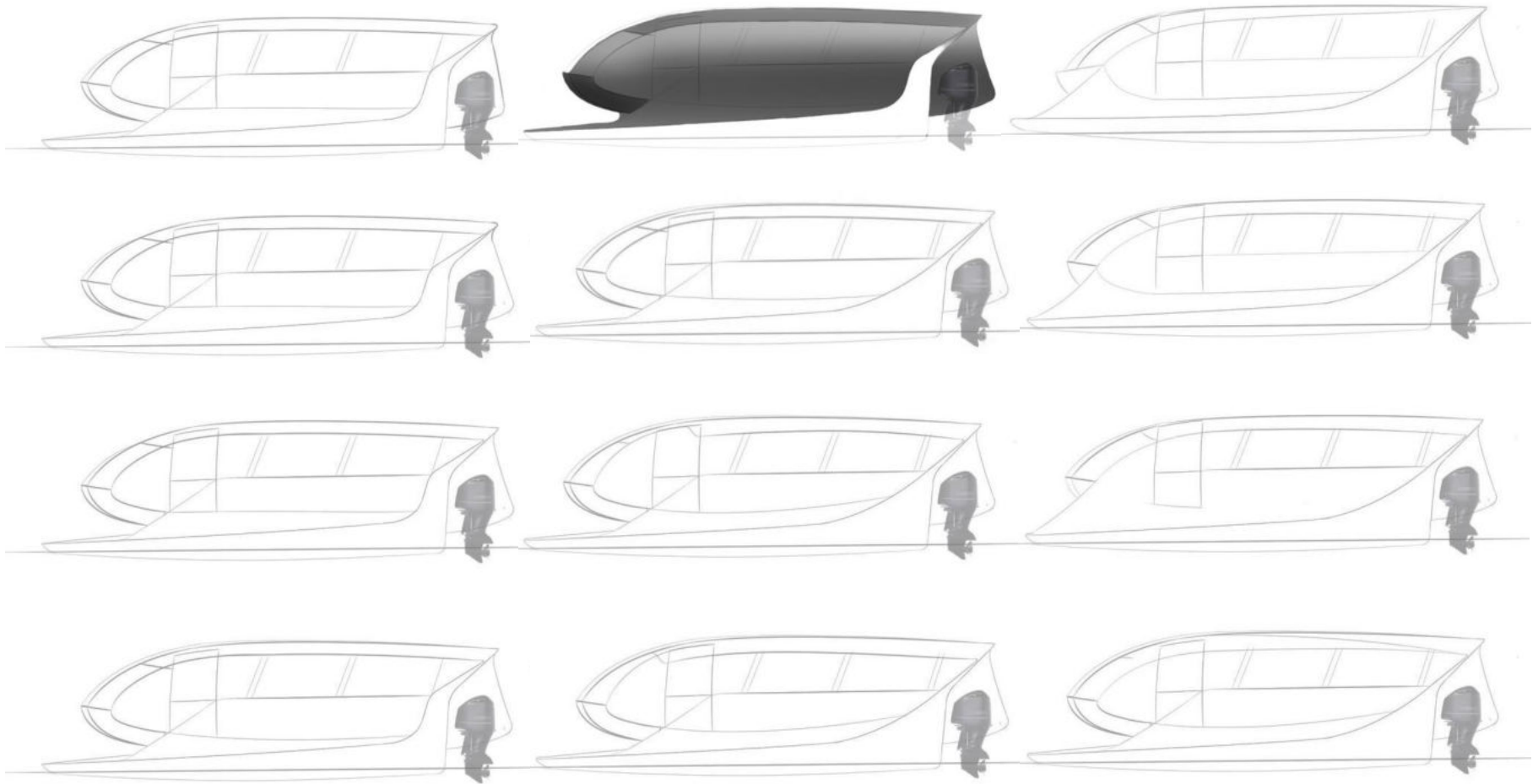

# Silhouette explorations

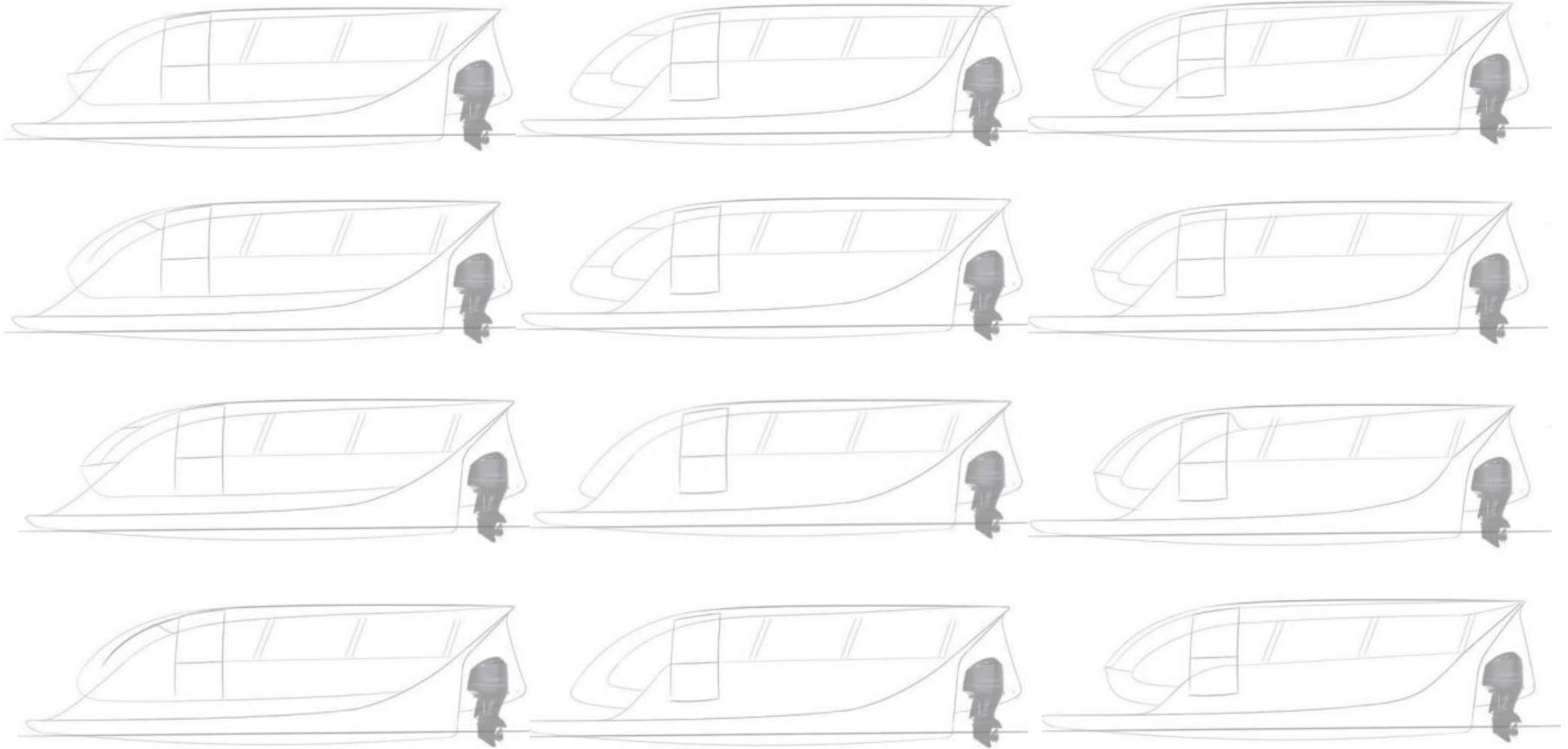

# Sketch development

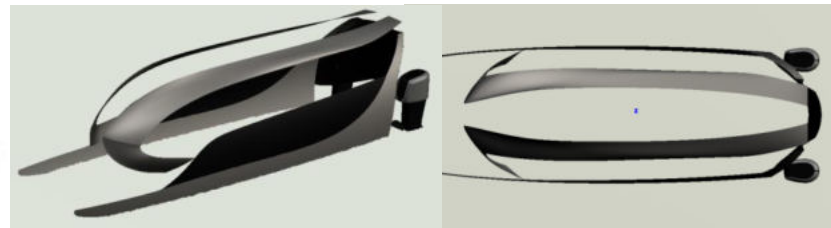
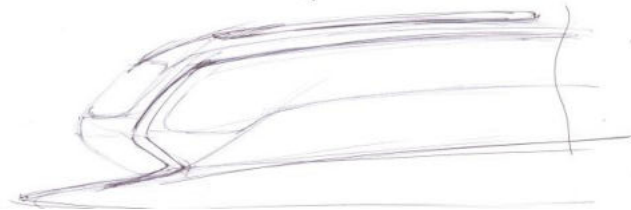
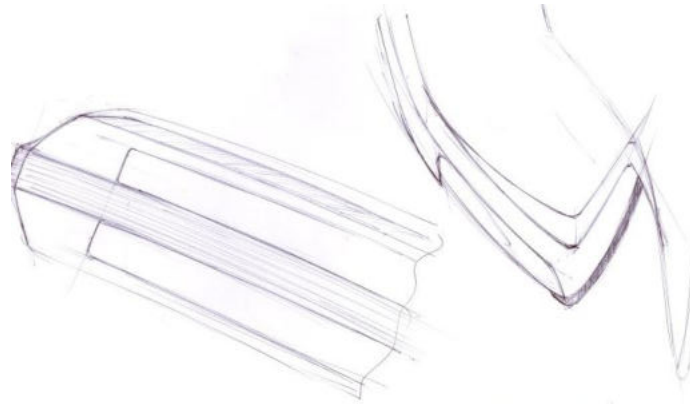
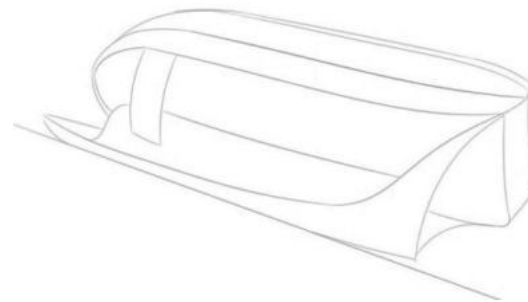
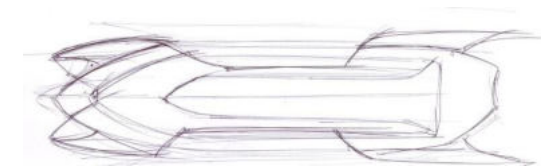
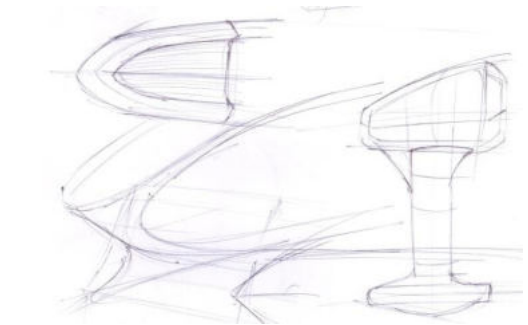

Design-1

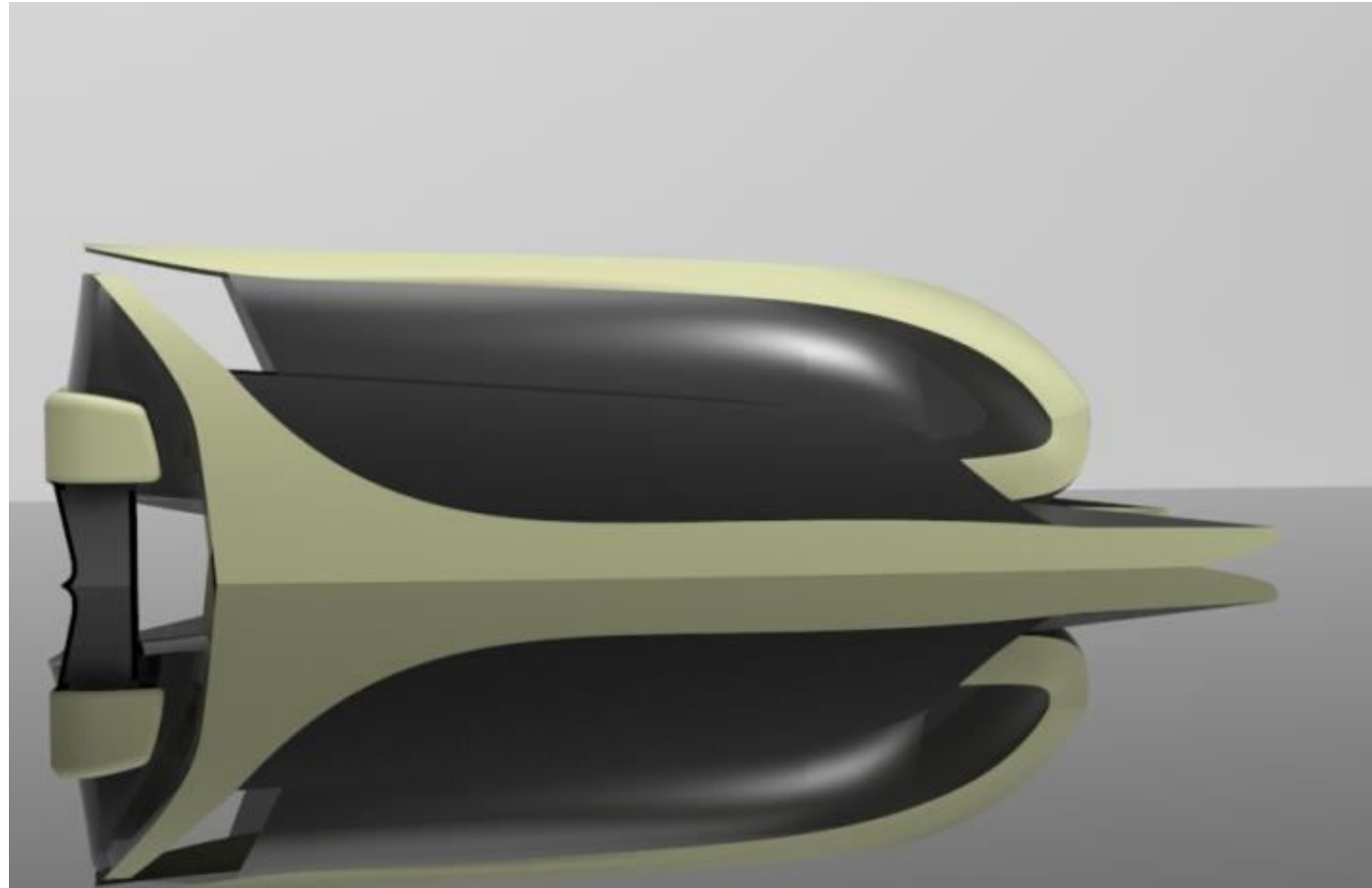

Images for inspiration

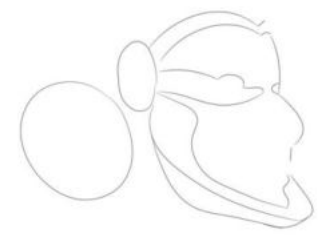
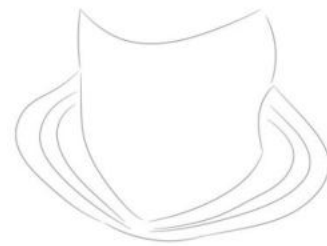

Images board



Inviting



Swiftness

Expressive



Safe



Design-2

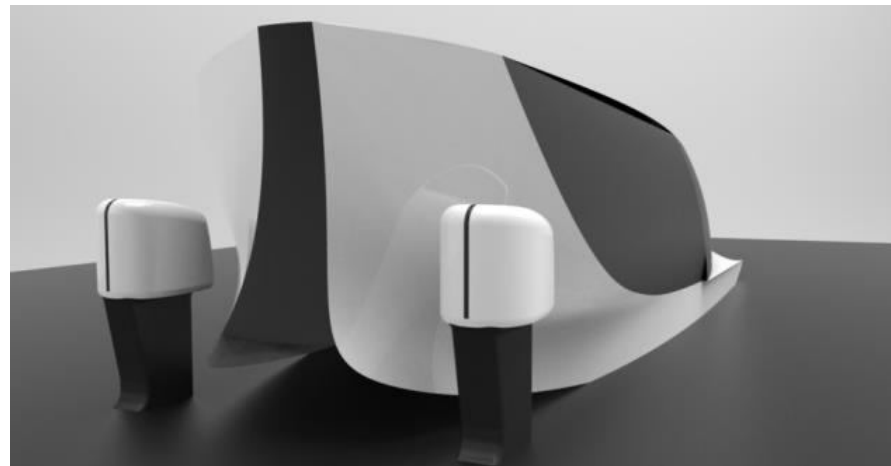
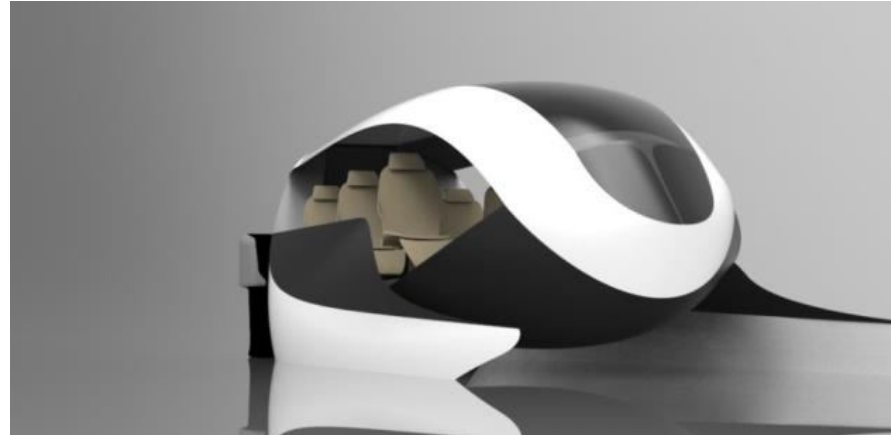

Design-3

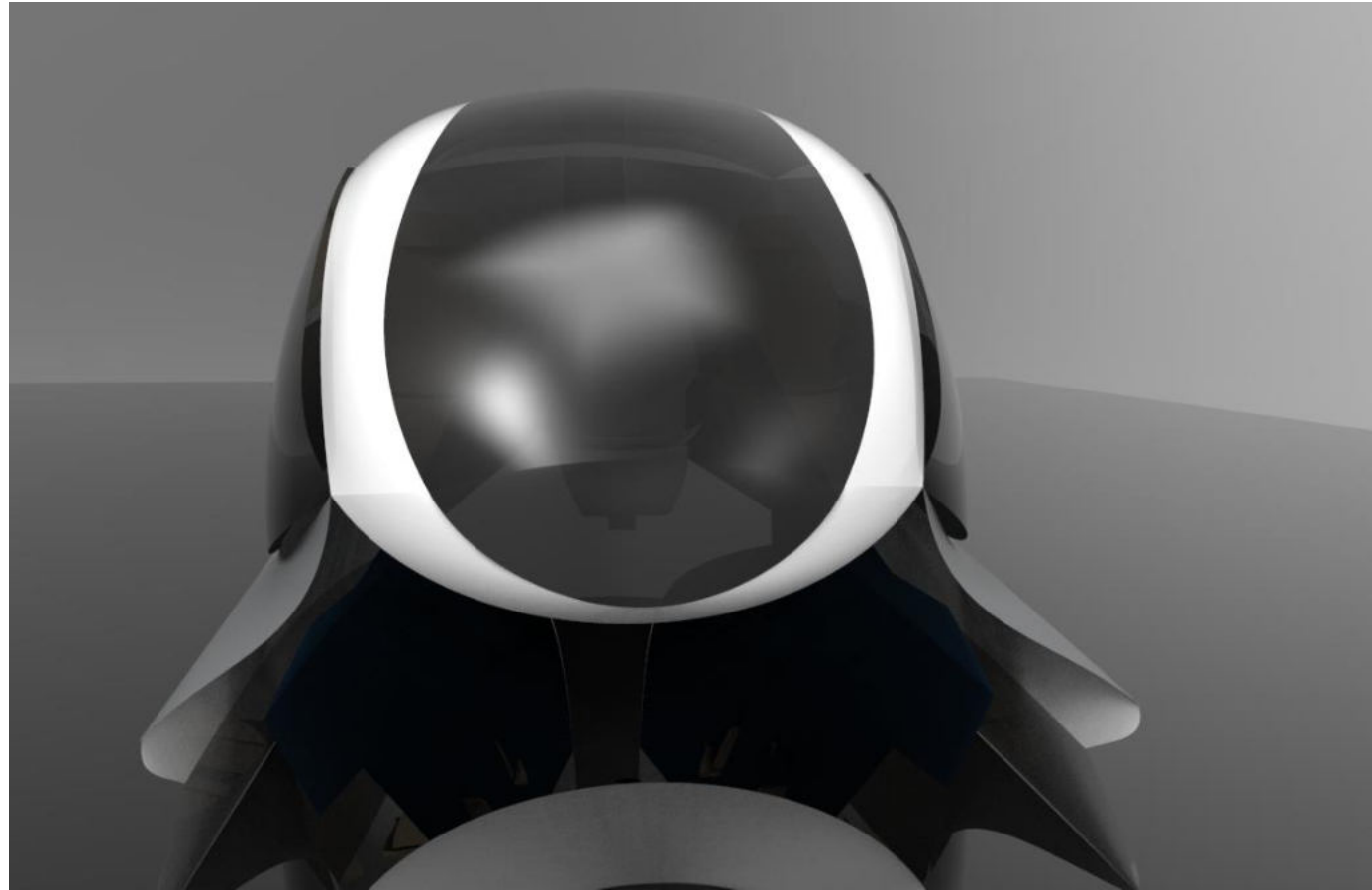

Design-4



Design-5

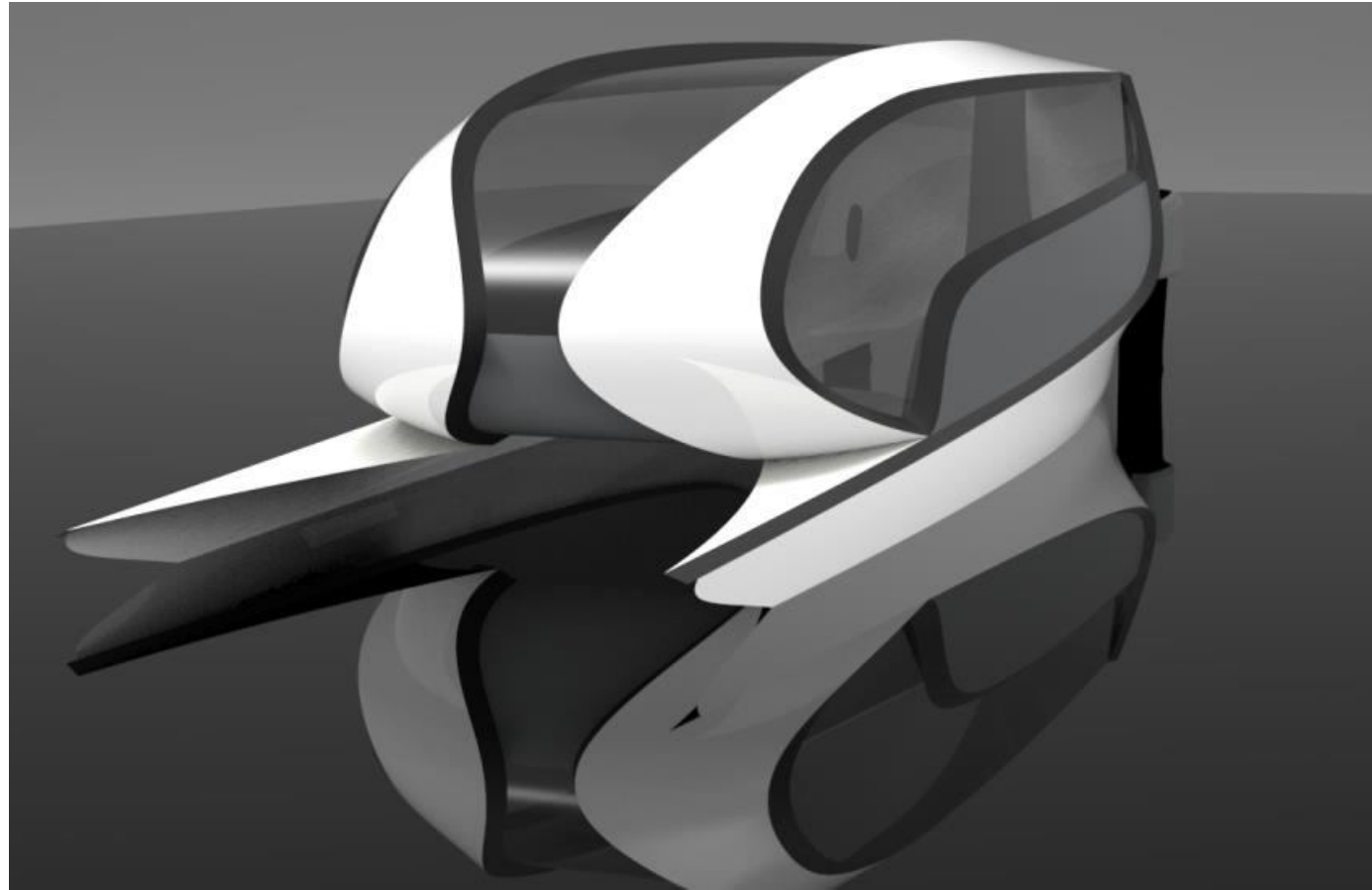

Design-6

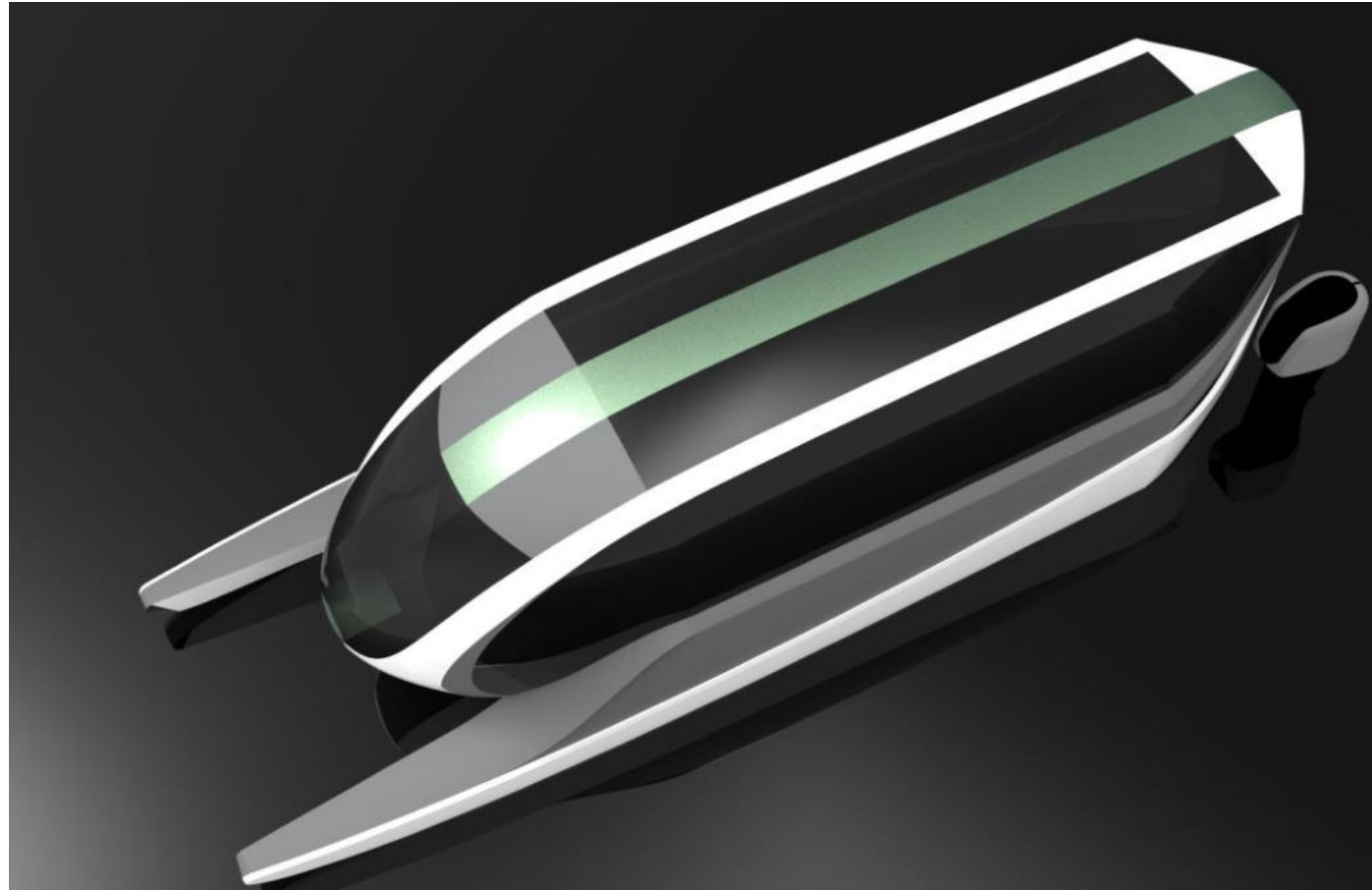

# Final concept

## Design-6 Exterior

*Design 6 being the most evolved and refined, is taken up as the final concept*

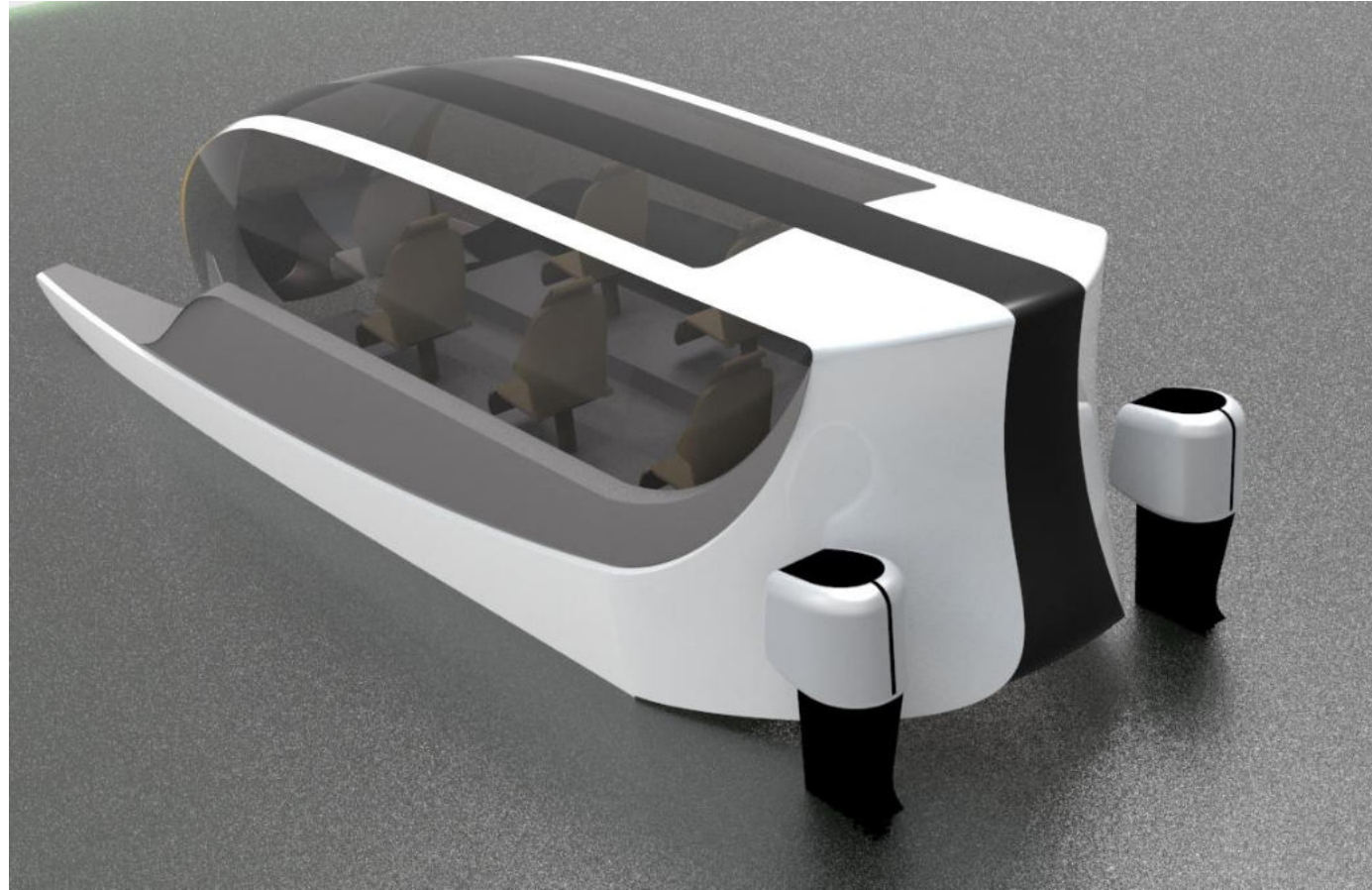

Final concept

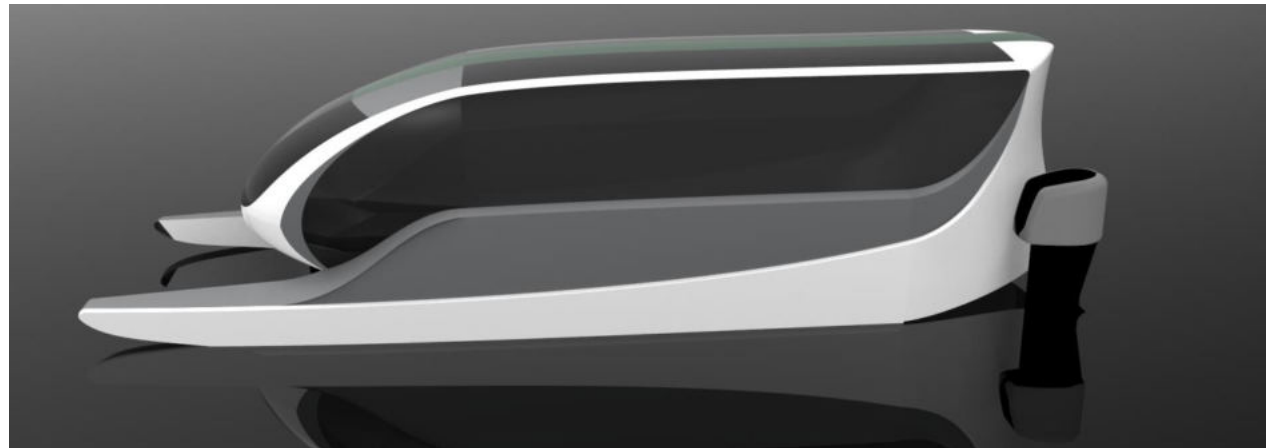
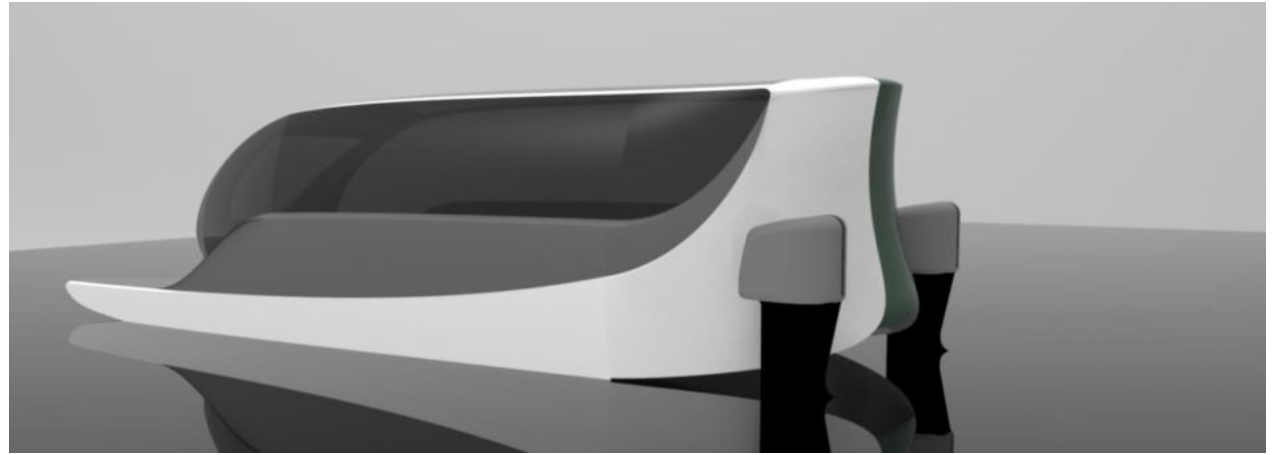

# Scaled model

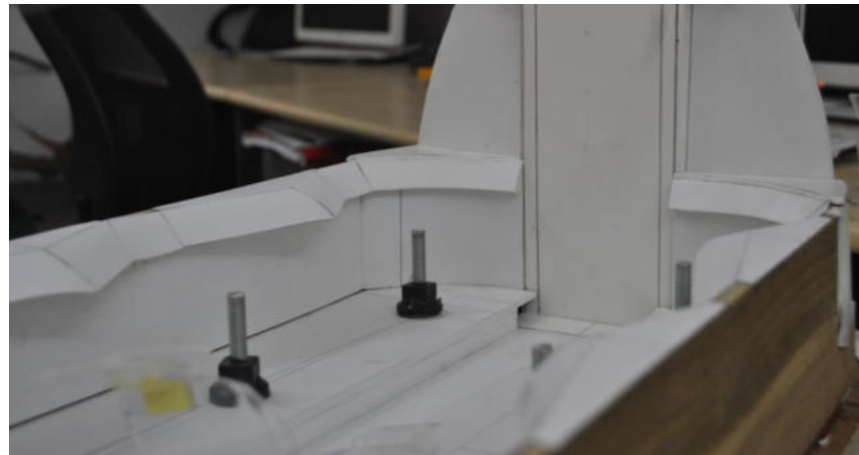

*Base of prototype is made from plywood.*

*Sun board and hard papers are used for defining interior space and panels.*

*Laser cut acrylic provides reference to the exterior volume.*

# Scaled model

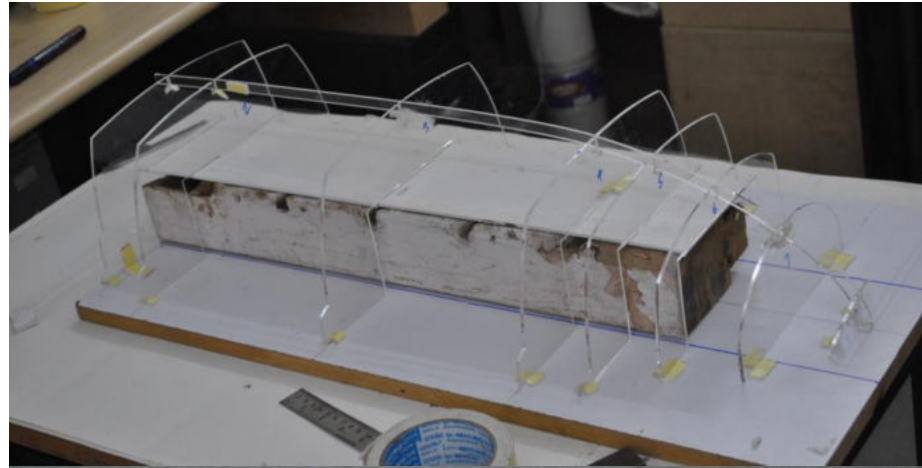

*Top part of super structure is made with cross sectional reference from CAD model. Laser cut acrylic are used for model reference.*

*Industrial clay is used as skin and is finished to define surfaces.*

*POP mould for vacuum forming is made from this model.*

# Scaled model



*Base is also covered with clay.  
The top part is placed to this base for  
corrections and refinement.*

# Scaled model



*Clay model with roof and window lines.*

# Scaled model



*Mould for vacuum forming*



# Scaled model

*Interior.*



# Scaled model



# Logo design

