

**Pakhi**

**BIOMIMETIC TOY FOR  
TODDLERS (9-15 MONTHS)**

**HAPPINESS**

**FUN**

**PLAY**

**Minal Agarwal**  
**146130002**

# Product Design –II Toy Design for kids taking Bionic Inspiration(9 to 15months)

## Characteristics of the toddler

Newly mobile and more vocal , the kid is full of , the kid is full of , enthusiasm and —sometimes —a very strong will.

## Early Learning



### PHYSICAL

Become a confident walker



### SOCIAL & EMOTIONAL

Show affection with hugs, kisses, smiles and pats



### COGNITIVE

Be better at entertaining herself, and more deliberate in exploring

## Making them learn more

Help a new walker practice balancing and walking by encouraging him/her bring a toy along on little excursions through the house. It will boost their confidence.

## Skills to be learnt

Action and reaction  
Cause and effect  
On and off

Stacking  
Effect of music  
Recognizing sounds  
Learning about shapes  
Alphabets and numbers

## User Study Interview 1

### Sumaira , 9 months

- Hanging toys
- Toys with movement
- Lights attract her
- Colors like red
- Or soft and squishy materials



## Interview 2



### Riyansh and Ridan , 18 and 12 ,months

- Love to play with kitchen utensils,
- Don't like playing with a single toy for long
- Prefer toys with keys, to see action and reactio
- They like to observe how parts use the toys.
- Few toys they get attached to.

## Interview 3

### Arya, 14 months

- Loves to play with stacking toys
- Soft toys
- Bright colors

## Interview 4

### -Adya, 18 months

- Loves to play with hanging toys
- Loves bright colors.
- Toys which make sounds



# Market Study



# Design Brief

## MUST HAVES

### PROBLEM

Designing a wooden toy for age 9-15 months

### USER REQUIREMENTS

- Should cater to the **curiosity** of the kid
- Should be **safe** in its usage, form-function and material
- Should have the **strength to withstand wear and tear**
- Should be visually approachable.

## MAY HAVES

- Should be **transformable** or should have the option to be used in multiple ways.
- Should help in the **physical development of the kid** by involving the movement of kid while operation
- Should be **unpredictable**.
- Should be **interactive**.

## SCOPE

The scope of the project includes:

- Working out the **basic design** of the toy.
- Working on the **mechanisms** of operation of the toy.
- Proceeding with the **form**
- And **manufacturing** of the wooden toy.

## PRODUCT LIFE CYCLE

To be used for a span of **about 1 year**



## USER AND TARGET GROUP

### PRIMARY USER

Kid between the age of 9 to 15 months.

### SECONDARY USER

Parents.  
Baby sitter  
Housemaid

### TERTIARY USER

Scrap pickers



<http://childadoption.in/west-bengal/>

## CONSTRAINTS

- Use of **wood** as the primary material.
- No involvement of electronics in the toy.
- Use of **simple mechanisms** to work out the movement.



<http://www.coalmerchantsfederation.co.uk/products/wood-logs>

## MICRO-ENVIRONMENT

To be used in the interiors of **Indian houses**

## BROAD PRODUCT SPECIFICATION

- Product should be majorly made out of wood.
- Should be around **1 feet in length**.

## FREQUENCY OF USAGE

Shall go to through **rough daily usage** by the kid.



<https://depositphotos.com/115373718/stock-photo-indian-kids-playing-with-block.html>

# IDEATION

Keeping in mind the User Studies, Market Studies and Bionic Inspiration, We proceeded with IDEATION.

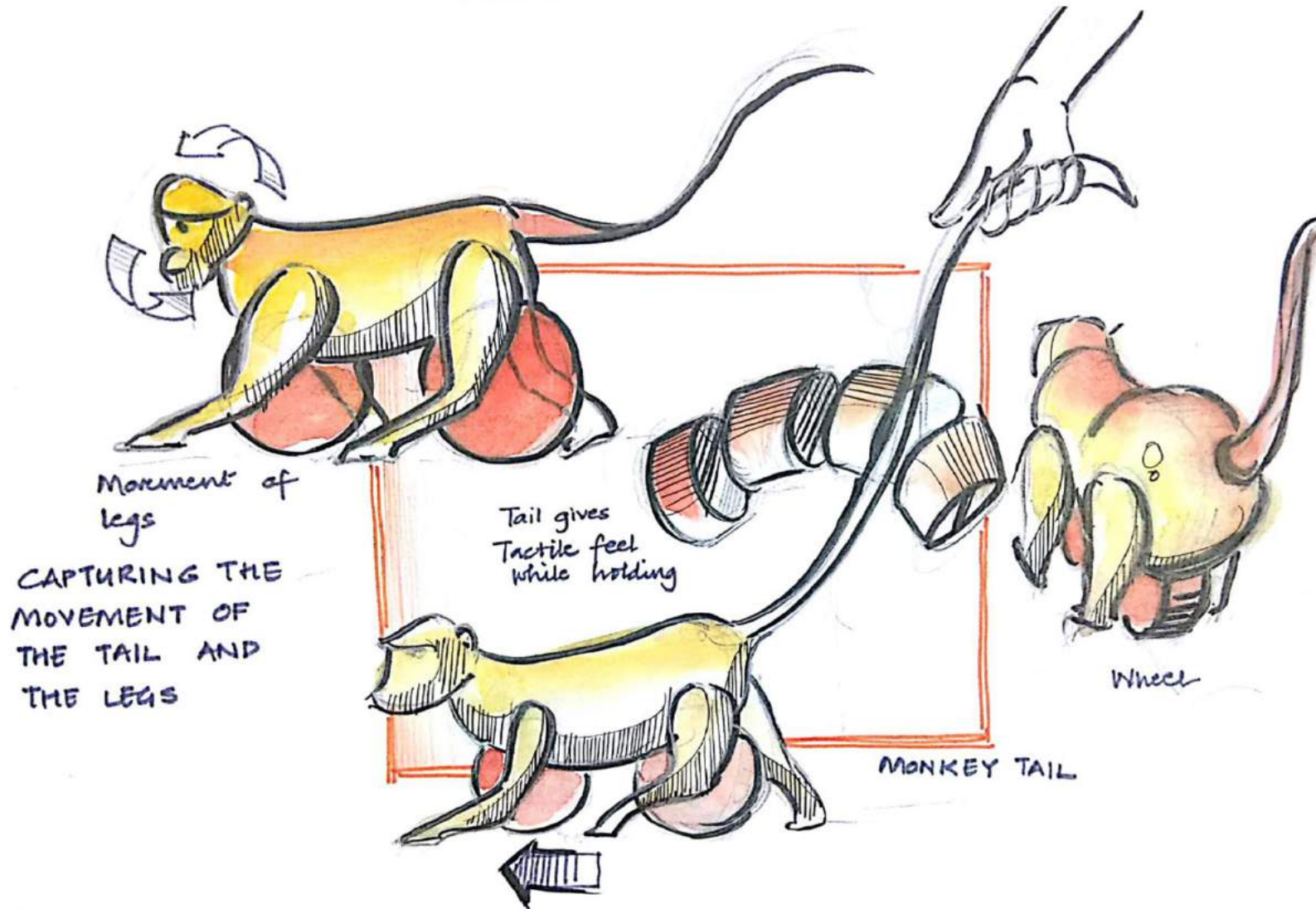

HANDLED BY THE TAIL

# IDEATION



②

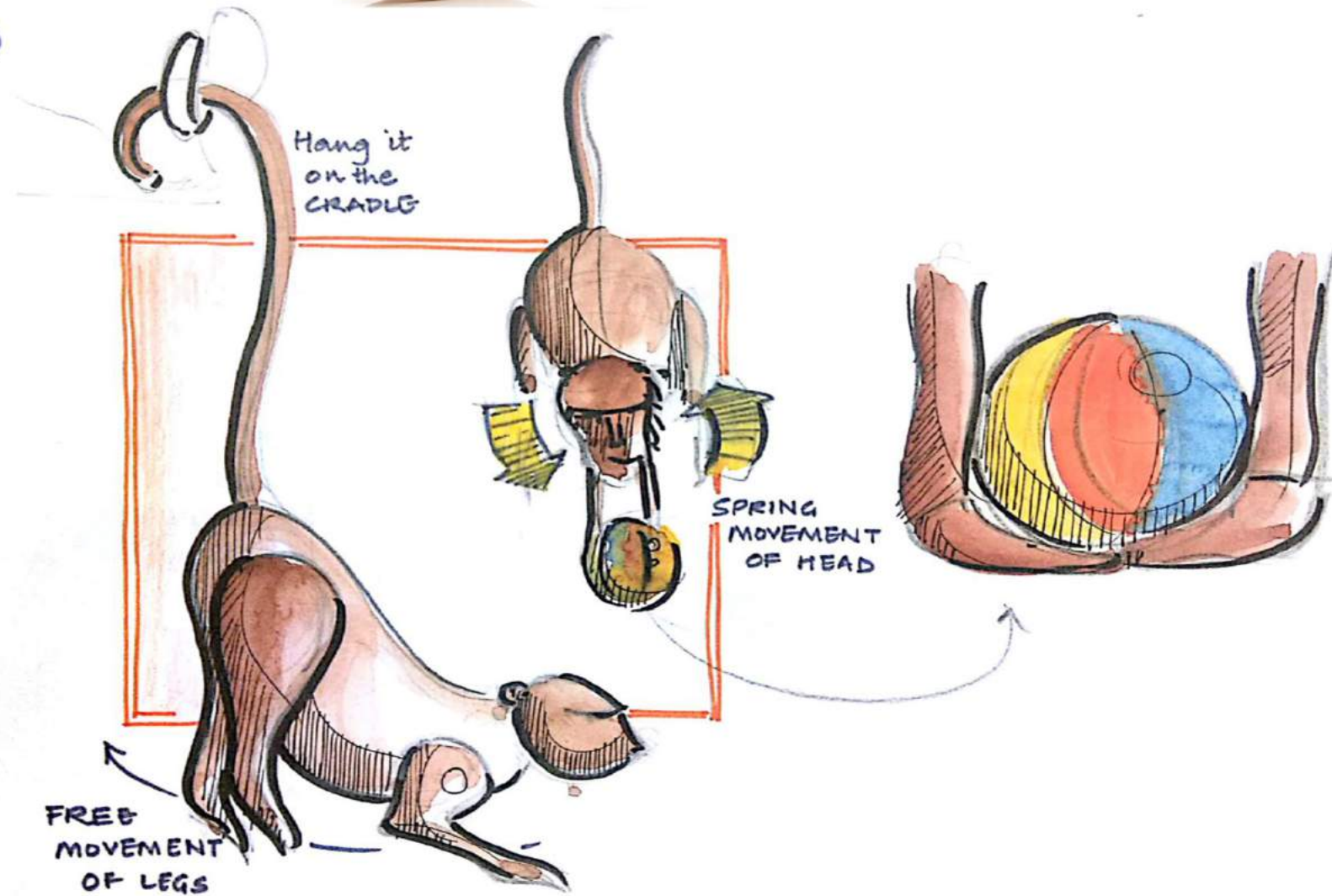

HANGING MONKEY

IDEATION



TACTILE TAIL



③

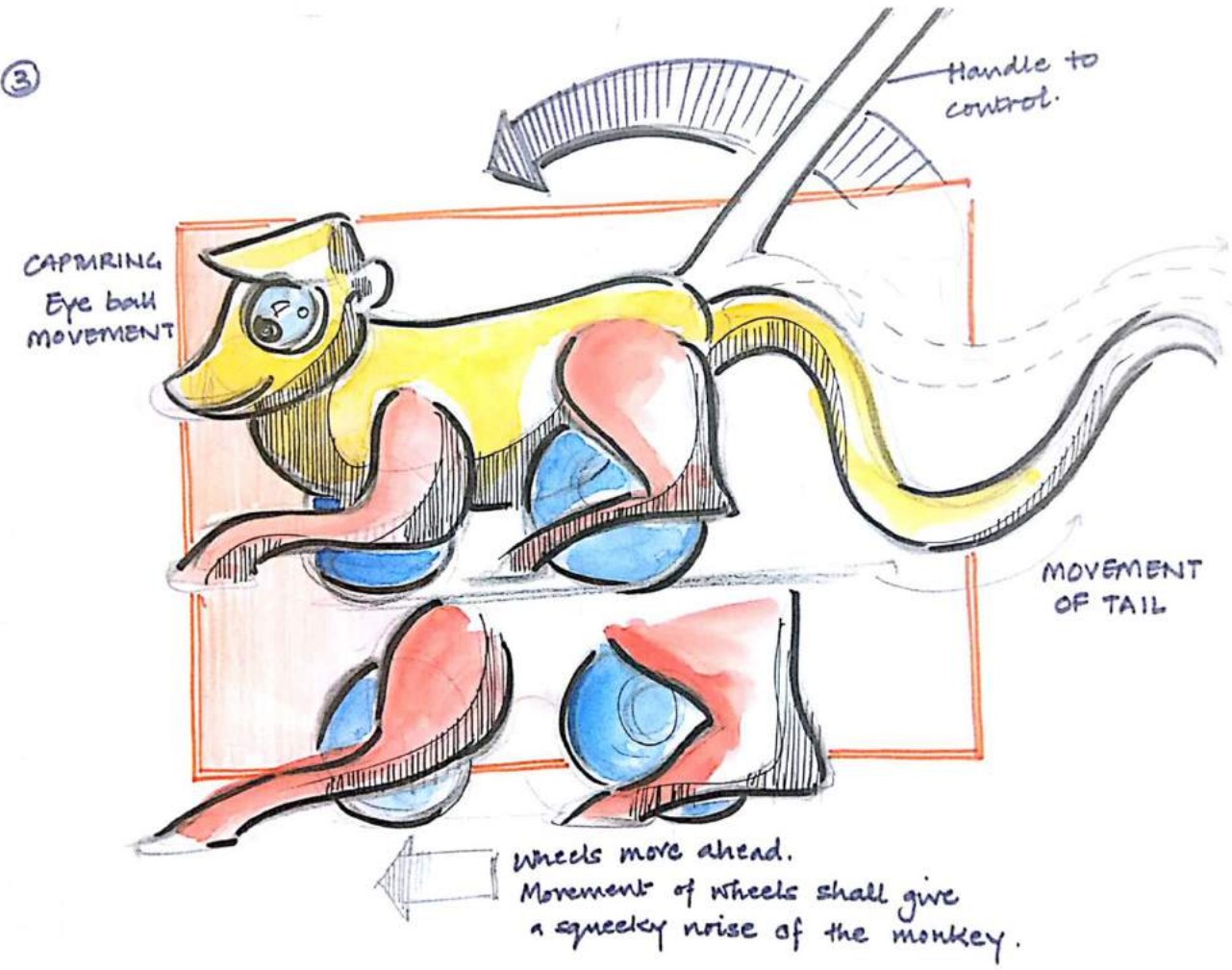



MUM AND BABY

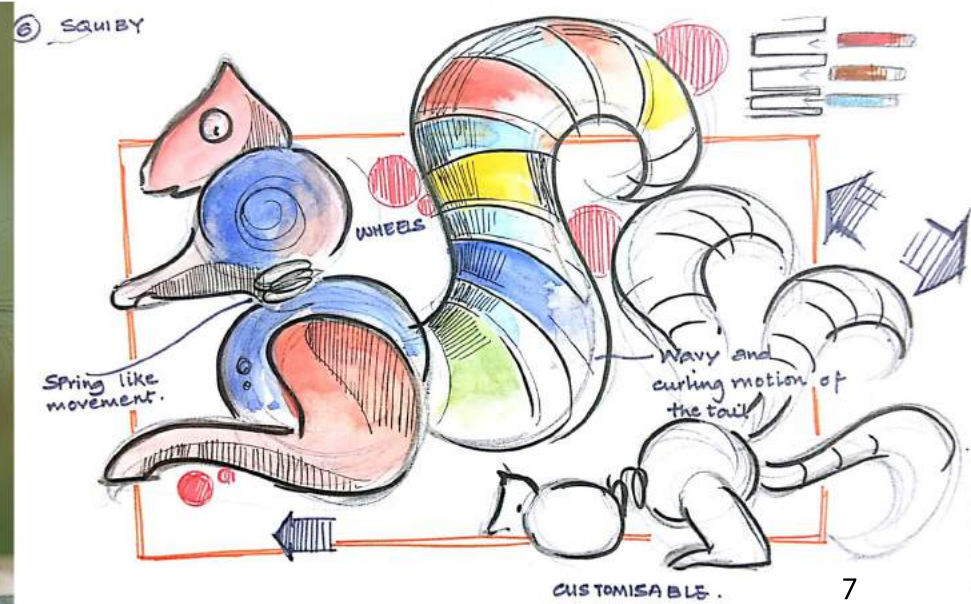
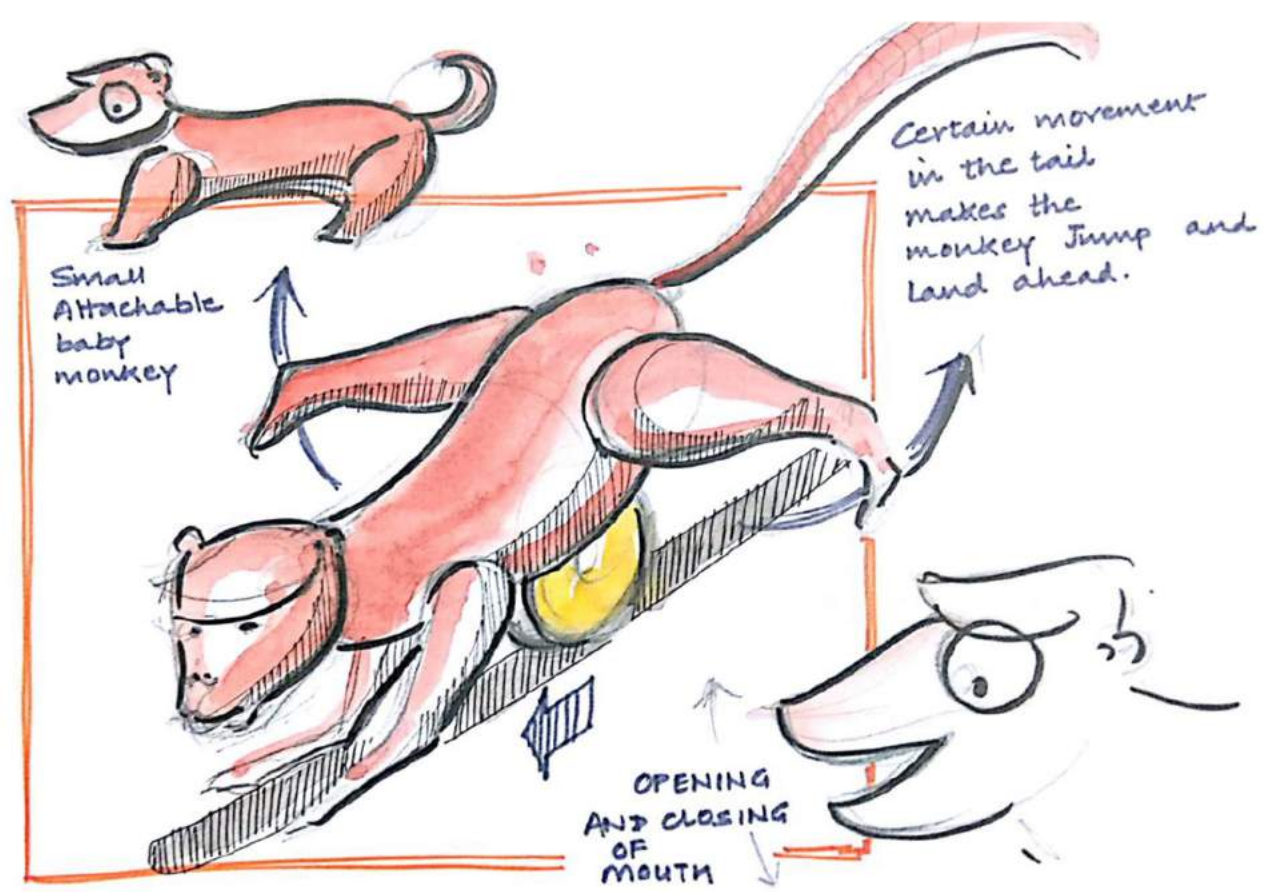



# MUSICAL MONKEY

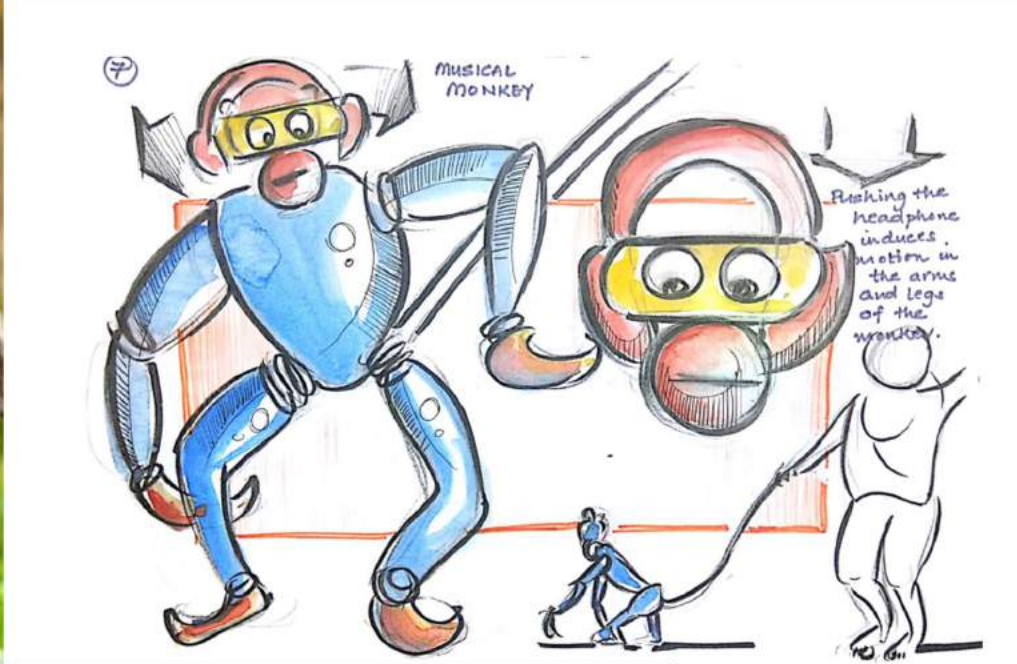

# INTERACTIVE TAIL

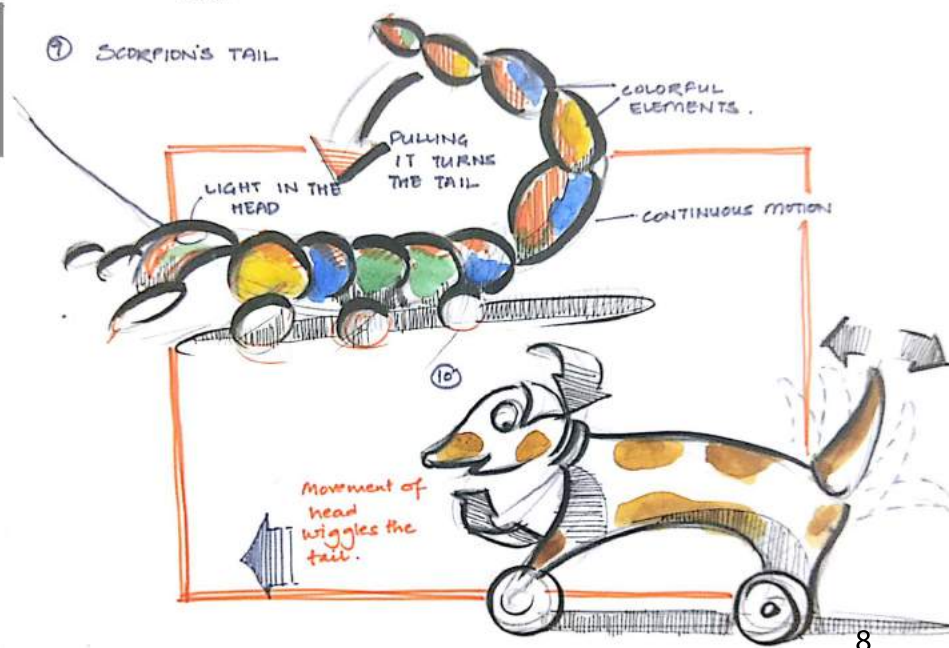
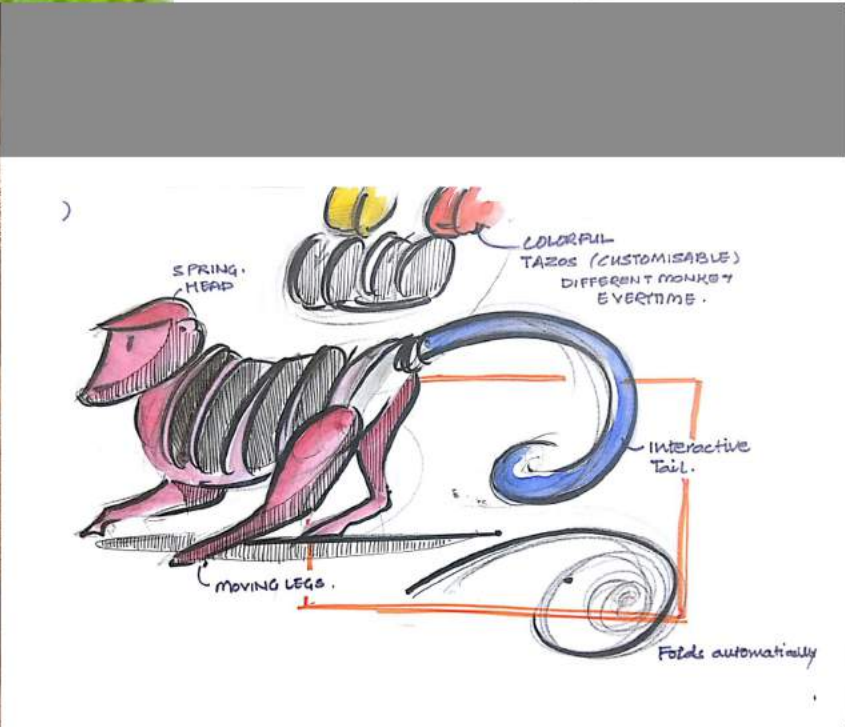

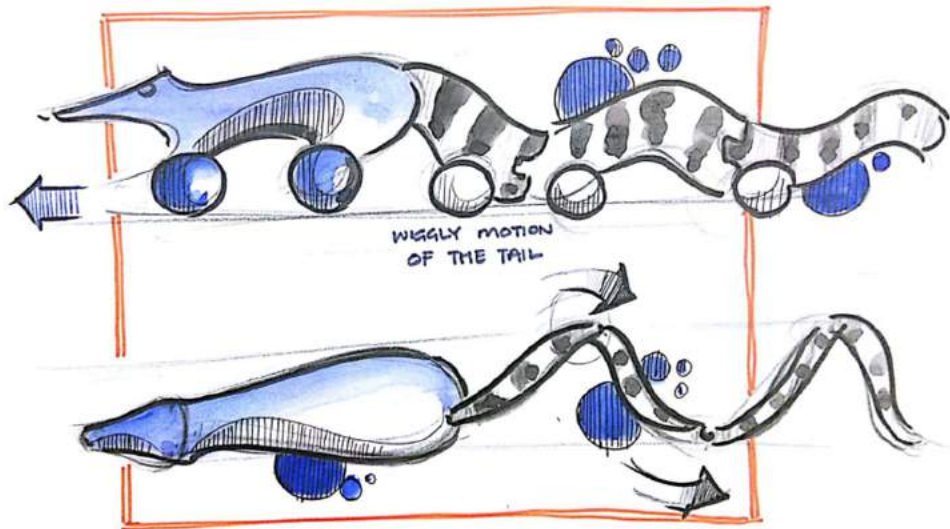

# NAUGHTY RACCOON

# GLASS FROG

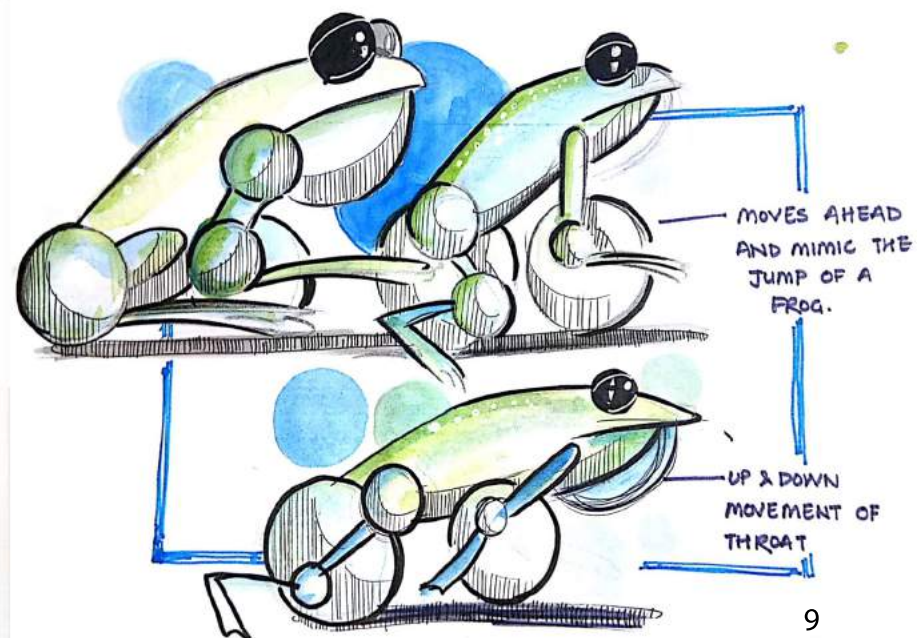



RED BIRD OF  
PARADISE



SPIDER  
MONKEY

# SHORTLISTED CONCEPTS

The concepts were shortlisted with the help of friends and classmates.

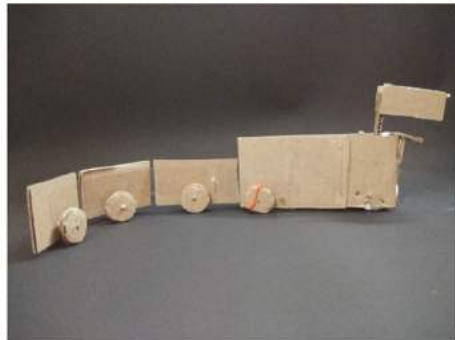
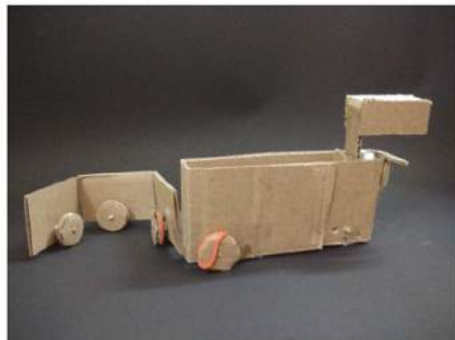

PROTOTYPES

# 1. NAUGHTY RACCOON

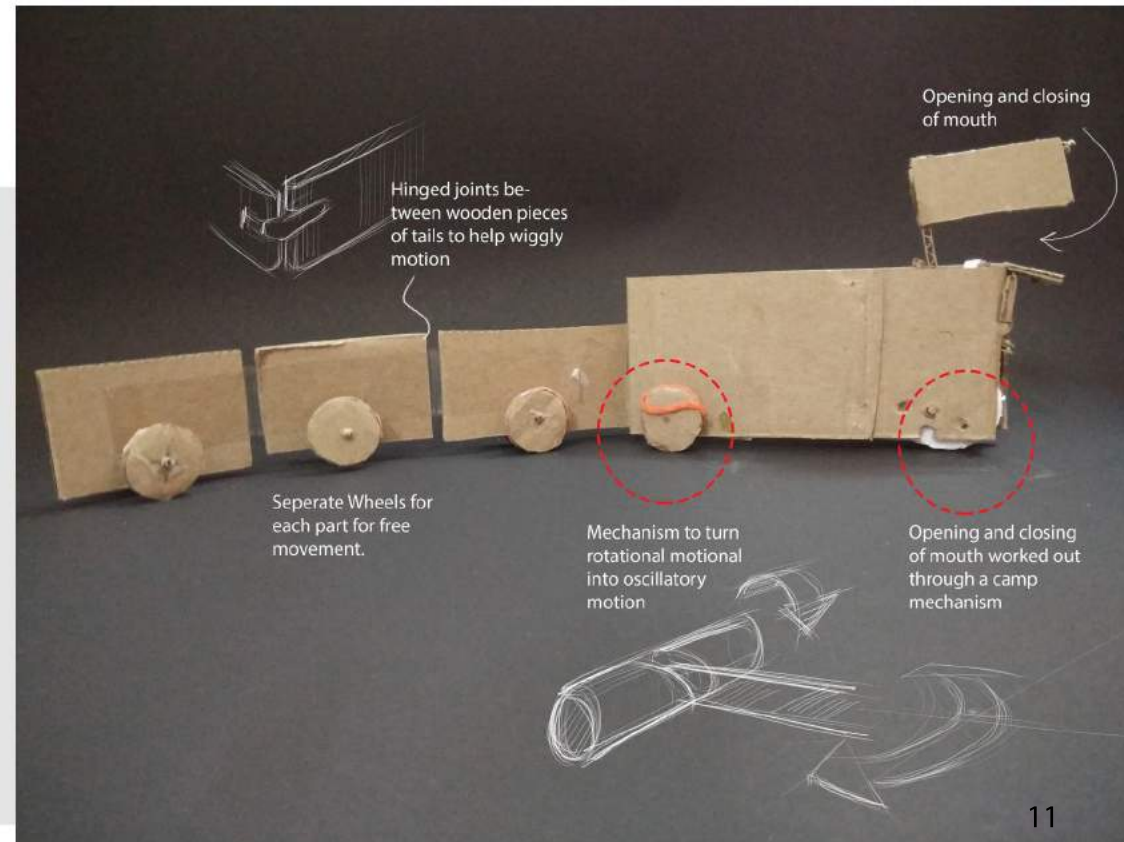
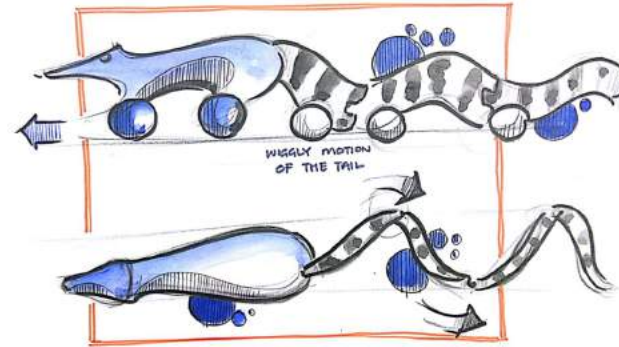

## 2. GLASS FROG

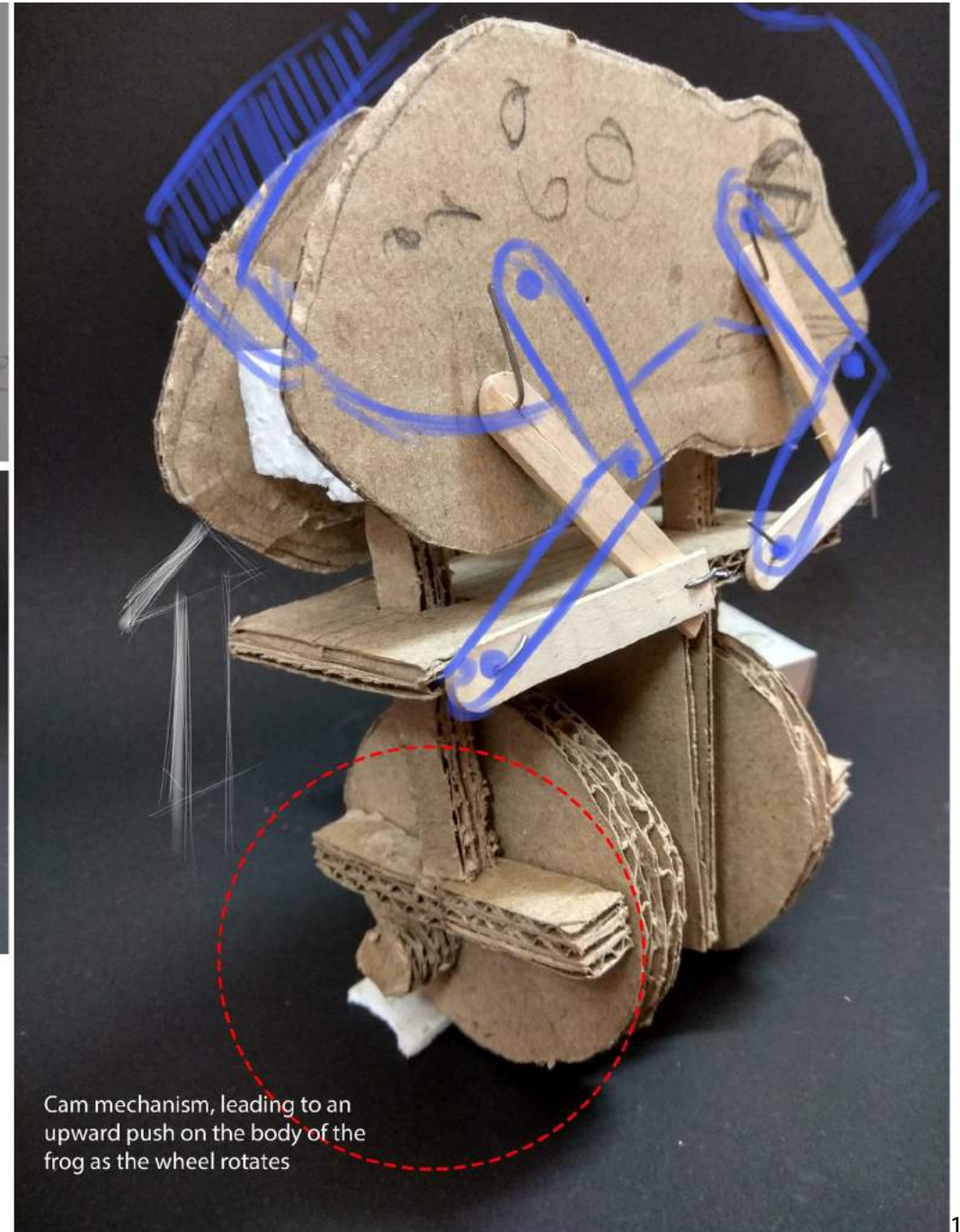
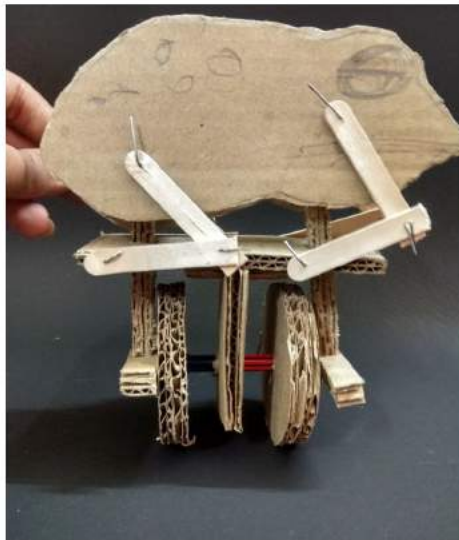
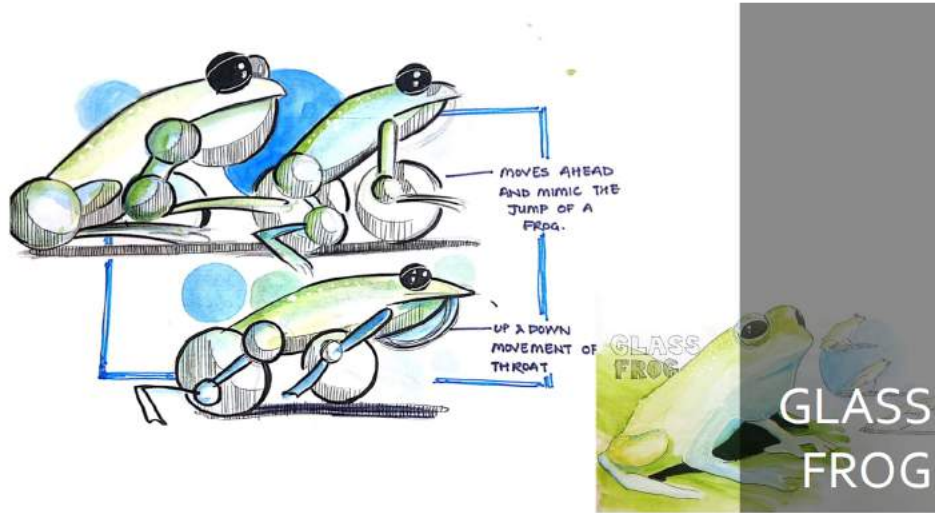

### 3. RED BIRD OF PARADISE

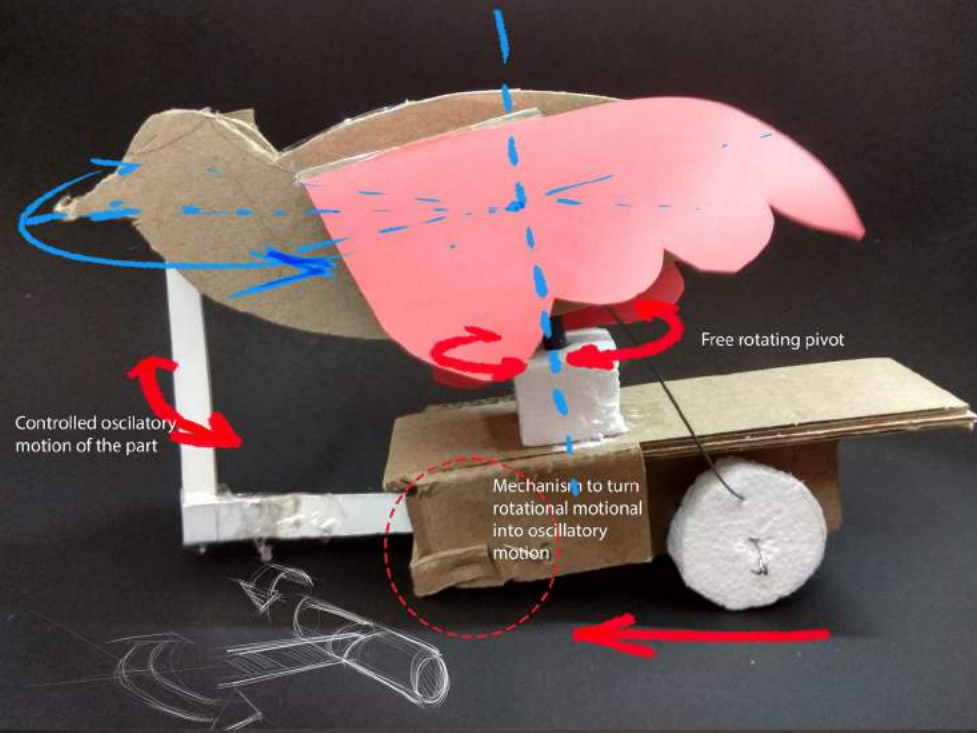

### PROTOTYPE

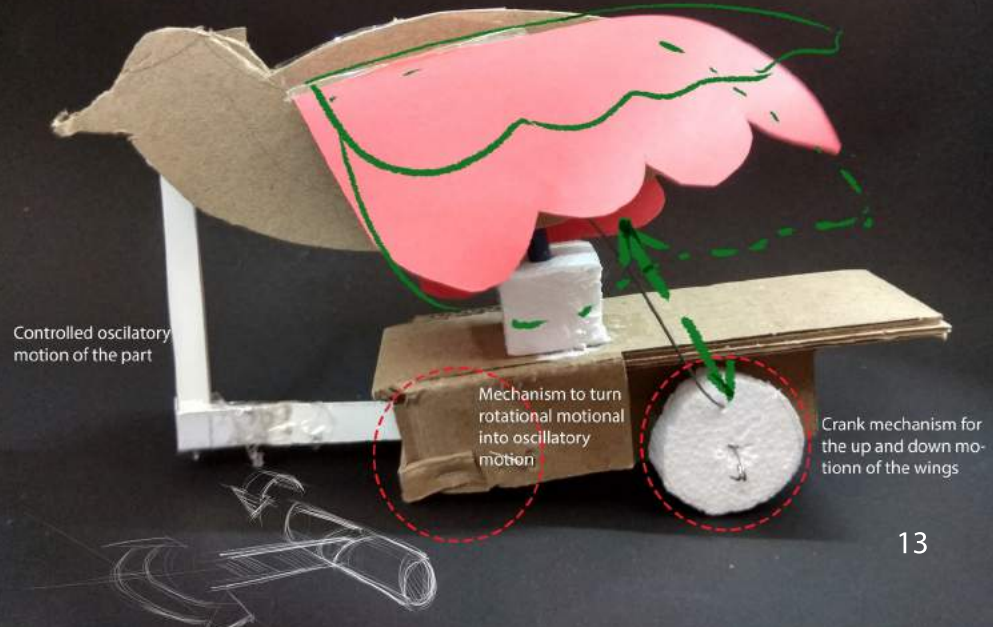
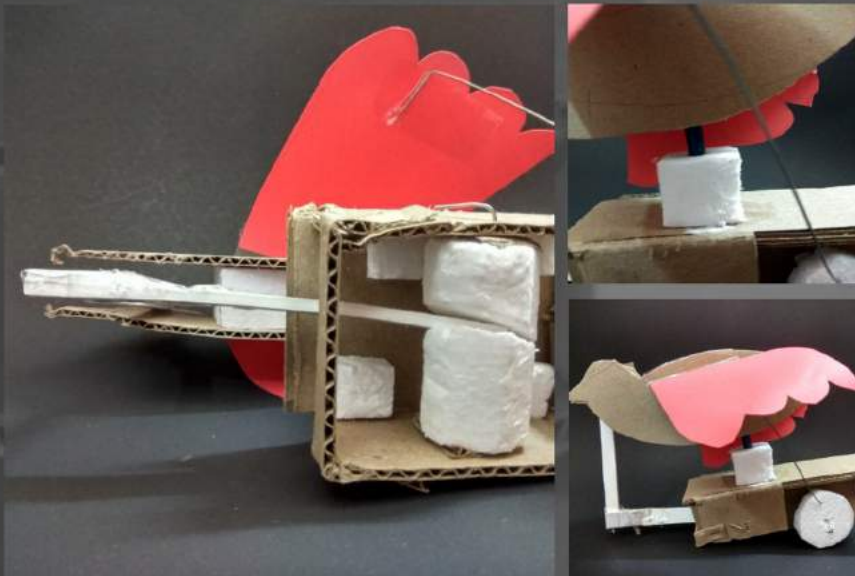

# FINAL CONCEPT

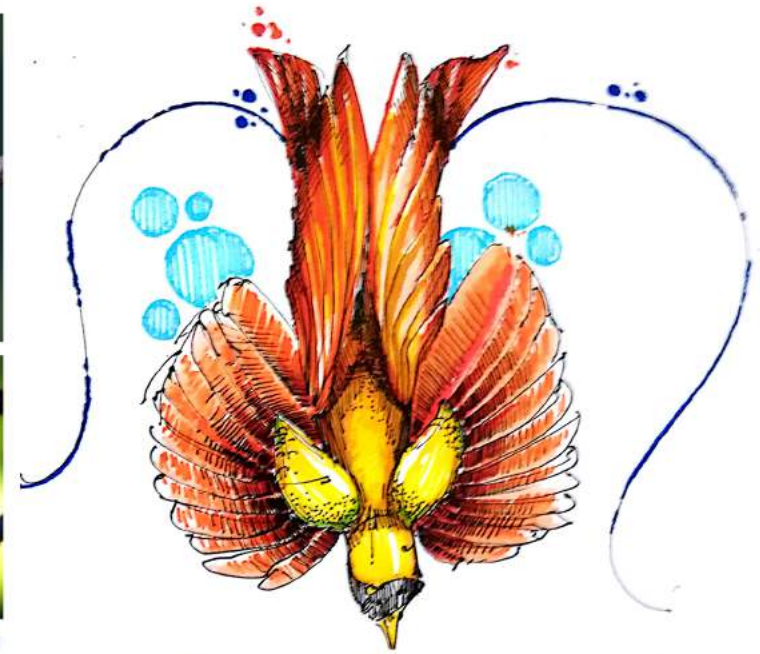

## Concept Sketches

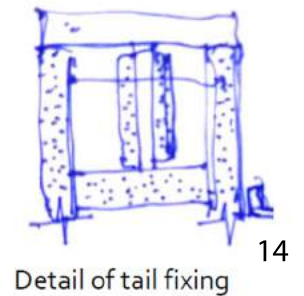
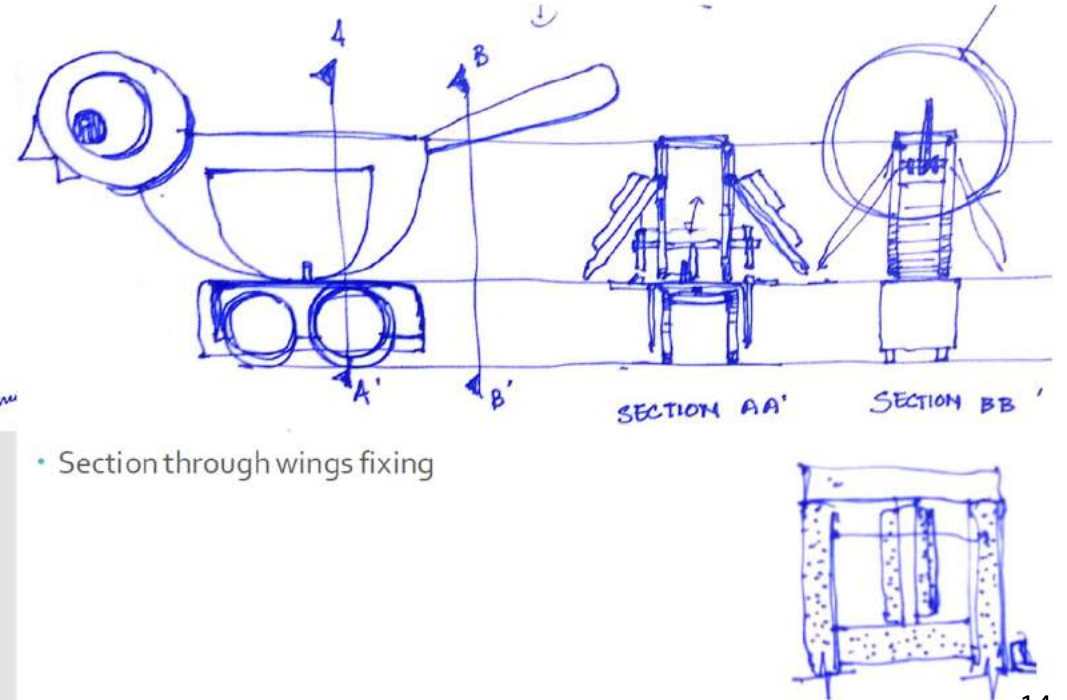
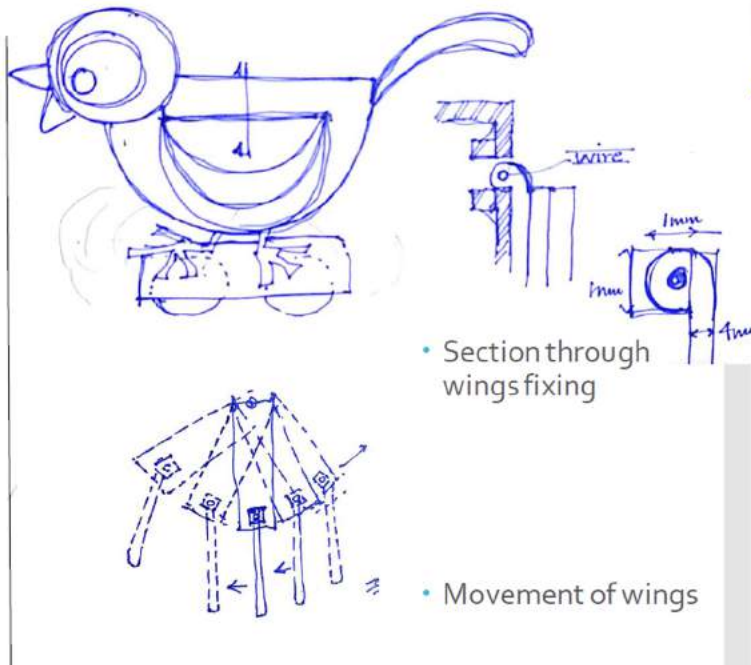
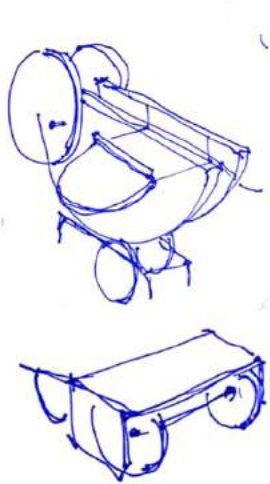

# Formal Variation Sketches

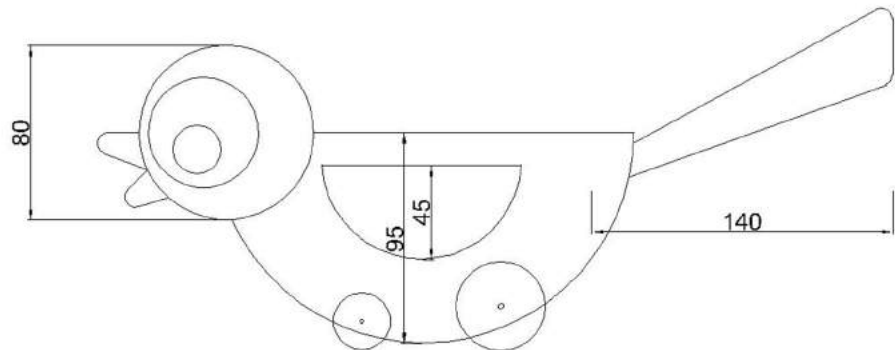
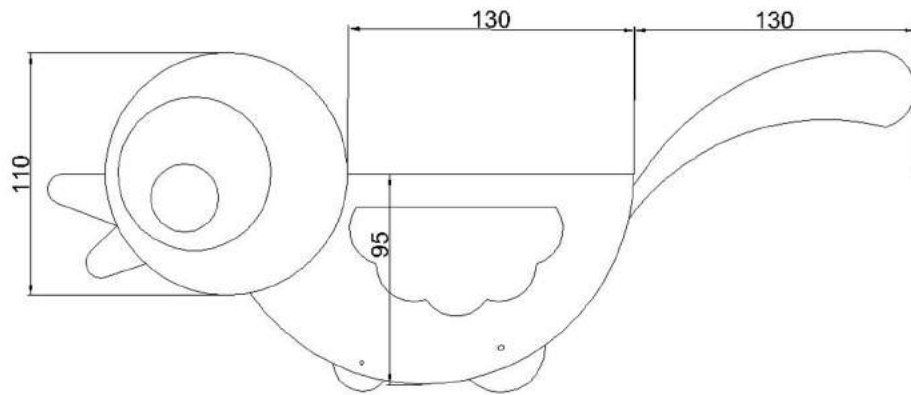
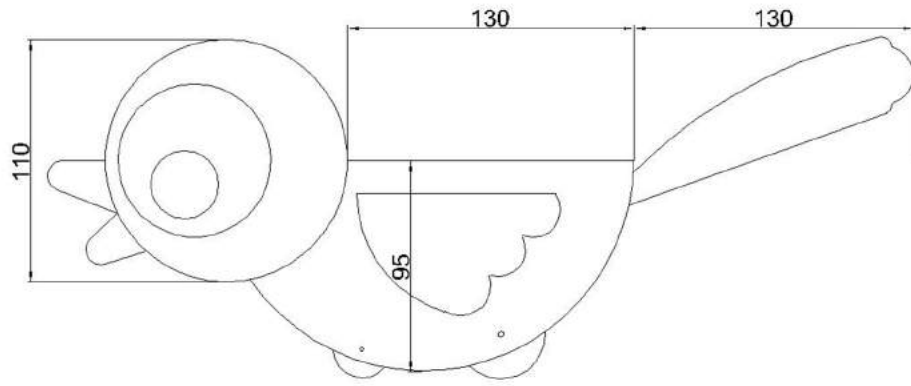

# Mechanical Drawings

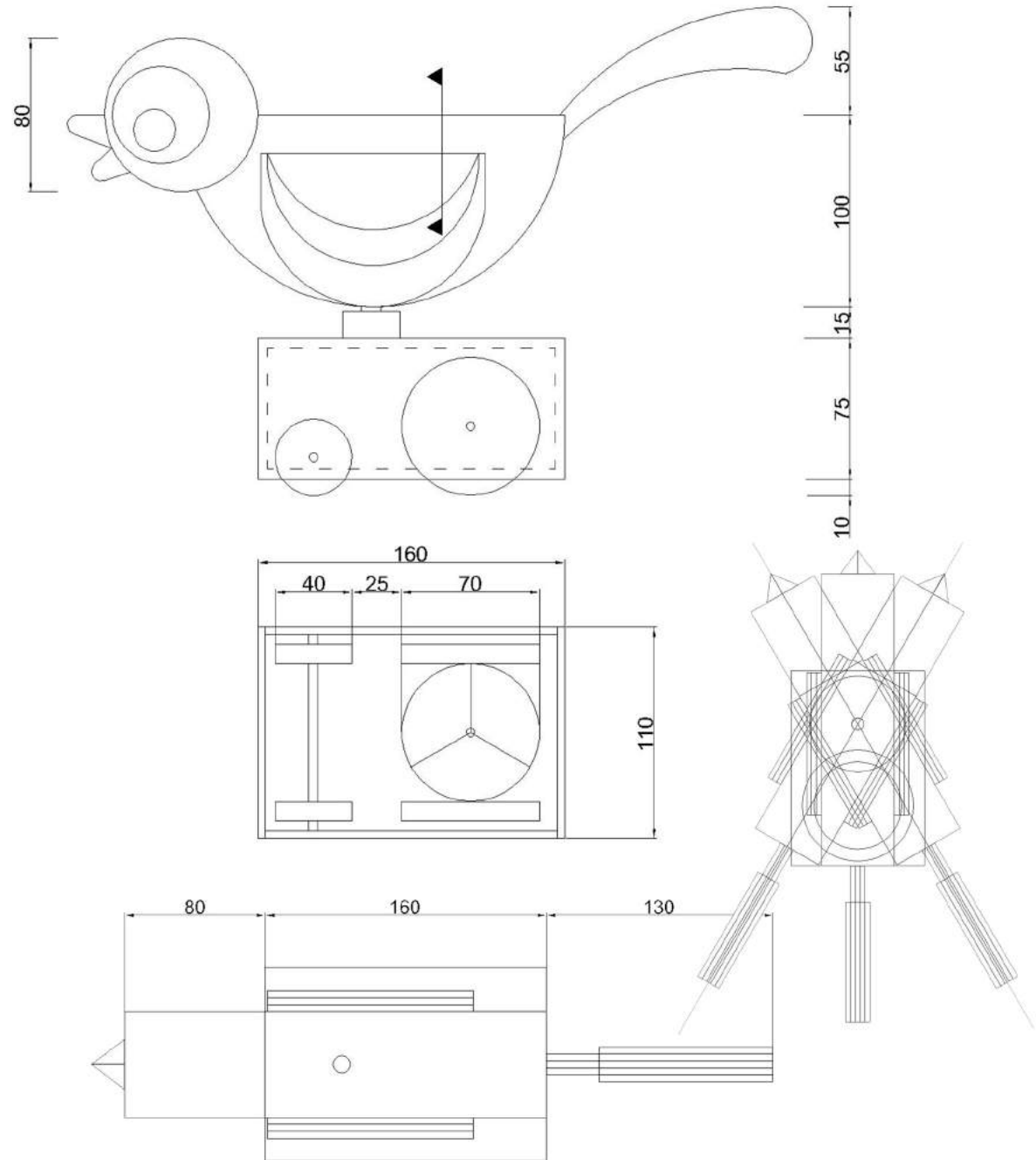



# Color Boards



Color Board inspired from Red Bird of Paradise

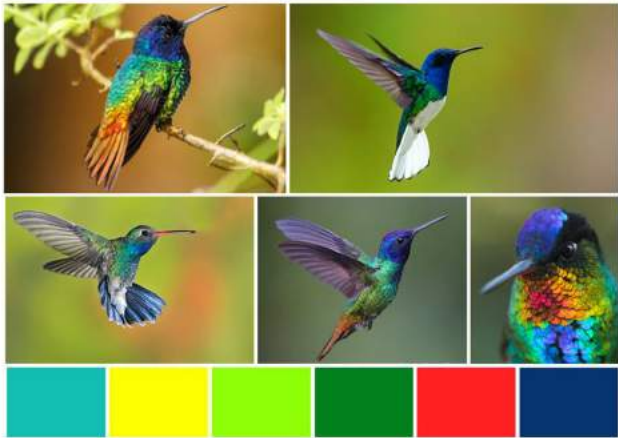

Final Color Variations, inspired from Kingfisher Bird



Color Board inspired from Humming Bird.

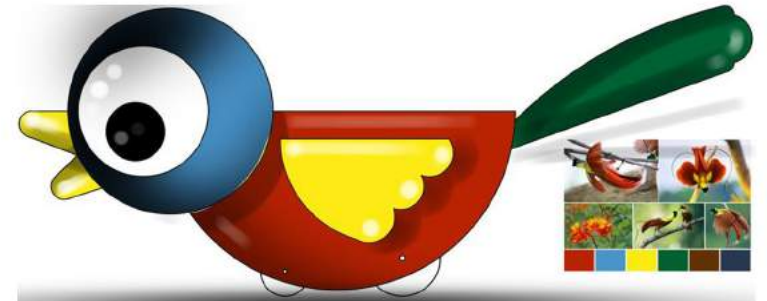

## Color Variations

Various Color boards were then taken as inspiration to design different color variations.

# Exploded View

Handle to push the toy ahead designed according to the height of the child

The free rotating tail around an axle induced by the movement of the body of the bird.

Layer of next and leaves to hide the bos containing the mechanism

Circular Wooden pieces cut and glued together

Hinged Joint for the movement of tail

Wooden leg which is also the free rotating pivot for the body of the bird.

Cam on the wheels to push the central wheel which rotates the bird

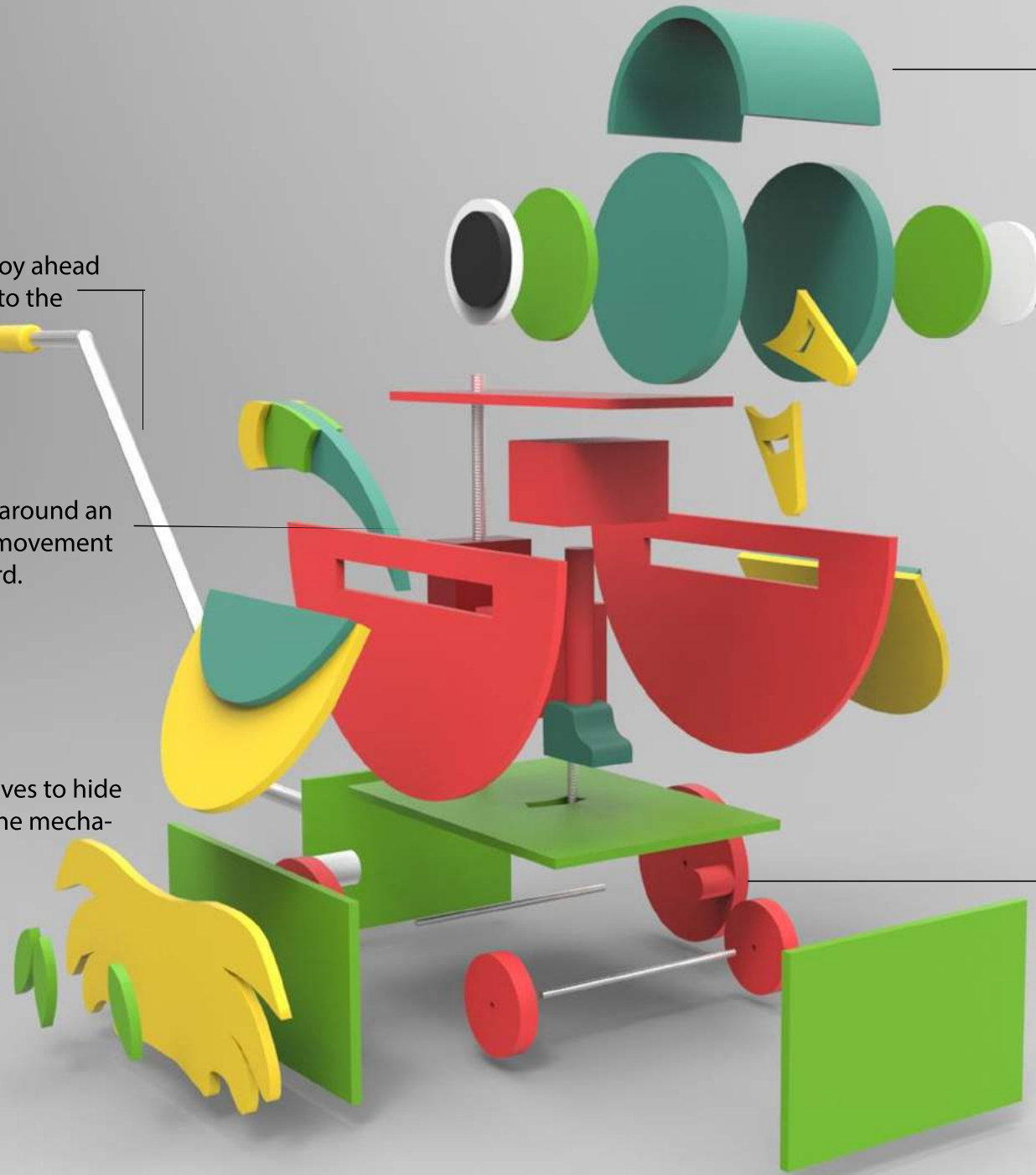



3-D Visualisation



Child's Perspective of the toy.

# Branding

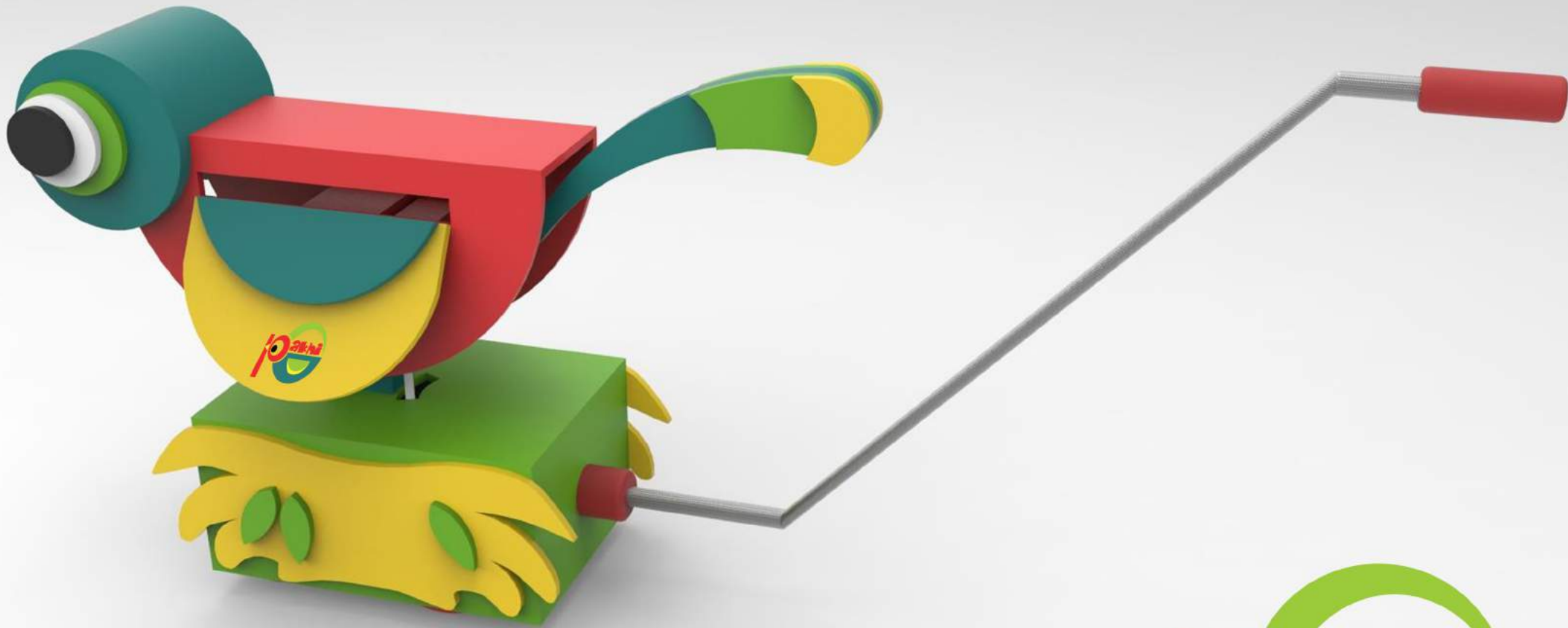

The reason for choosing this logo was that it highlighted the basic elements of the toy as well as provides a closed shape which can be noticed from a distance. The font also complements the quirkiness of the bird.



Final Model



## References



[www.amazon.in](http://www.amazon.in)

<https://www.google.co.in/url?sa=i&rct=j&q=&esrc=s&source=images&cd=&cad=rja&uact=8&ved=2ahUKEwjP8rPqkbDaAhVGPY8KHeDvDQUQjRx6BAGAEAU&url=https%3A%2F%2Fwww.istockphoto.com%2Fphotos%2Fmonkey&psig=AOvVaw1CAOTcJoKUCVHekGlvVRjI&ust=1523464539783800>

<https://www.google.co.in/url?sa=i&rct=j&q=&esrc=s&source=images&cd=&cad=rja&uact=8&ved=2ahUKEwjFgJ2doLDAhVEqI8KHQKMB4UQjRx6BAGAEAU&url=https%3A%2F%2Fwww.art.com%2Fproducts%2Fp10182106968-sa-i5919425%2Fpete-oxford-white-fronted-capuchin-monkey-hanging-from-a-tree-puerto-misahualli-amazon-rain-forest-ecuador.htm&psig=AOvVaw1ebDrFO85fynpeFqQWVMIS&ust=1523468404412549>

<https://www.npr.org/sections/13.7/2017/04/25/525363273/what-s-it-like-to-be-squirrel>

[https://www.google.co.in/url?sa=i&rct=j&q=&esrc=s&source=images&cd=&ved=2ahUKEwiX\\_8OOobDaAhWHsY8KHQ8VBXoQjRx6BAGAEAU&url=https%3A%2F%2Fen.wikipedia.org%2Fwiki%2FScorpion&psig=AOvVaw1ccM\\_tPIVFCF8LMBDkk-z9&ust=1523468641110639](https://www.google.co.in/url?sa=i&rct=j&q=&esrc=s&source=images&cd=&ved=2ahUKEwiX_8OOobDaAhWHsY8KHQ8VBXoQjRx6BAGAEAU&url=https%3A%2F%2Fen.wikipedia.org%2Fwiki%2FScorpion&psig=AOvVaw1ccM_tPIVFCF8LMBDkk-z9&ust=1523468641110639)

[https://www.google.co.in/url?sa=i&rct=j&q=&esrc=s&source=images&cd=&ved=2ahUKEwiP9dysobDaAhVFM48KHYSrA\\_8QjRx6BAGAEAU&url=https%3A%2F%2Fpets.knoji.com%2Flovely-ticked-speckled-and-marbled-with-brown-dog-breeds%2F&psig=AOvVaw2OOoMxdLxEGB3W97pJw2vO&ust=1523468700024973](https://www.google.co.in/url?sa=i&rct=j&q=&esrc=s&source=images&cd=&ved=2ahUKEwiP9dysobDaAhVFM48KHYSrA_8QjRx6BAGAEAU&url=https%3A%2F%2Fpets.knoji.com%2Flovely-ticked-speckled-and-marbled-with-brown-dog-breeds%2F&psig=AOvVaw2OOoMxdLxEGB3W97pJw2vO&ust=1523468700024973)

[https://www.google.co.in/url?sa=i&rct=j&q=&esrc=s&source=images&cd=&cad=rja&uact=8&ved=2ahUKEwir\\_63gl7DaAhWHto8KHeeqCRUQjRx6BAGAEAU&url=http%3A%2F%2Fbugstopper.com%2Ftop-tips-keeping-wildlife-wild%2F&psig=AOvVaw3skMA9DDwsl1jOJhMdd6NA&ust=1523465616322933](https://www.google.co.in/url?sa=i&rct=j&q=&esrc=s&source=images&cd=&cad=rja&uact=8&ved=2ahUKEwir_63gl7DaAhWHto8KHeeqCRUQjRx6BAGAEAU&url=http%3A%2F%2Fbugstopper.com%2Ftop-tips-keeping-wildlife-wild%2F&psig=AOvVaw3skMA9DDwsl1jOJhMdd6NA&ust=1523465616322933)

<https://www.google.co.in/url?sa=i&rct=j&q=&esrc=s&source=images&cd=&cad=rja&uact=8&ved=2ahUKEwiHn7bgmLDAhVDtl8KHXdNnAZEQjRx6BAGAEAU&url=https%3A%2F%2Fwww.telegraph.co.uk%2Fnews%2F2016%2F11%2F24%2Fsuicide-attack-squirrel-carries-kamikaze-attack-anti-squirrel%2F&psig=AOvVaw3skMA9DDwsl1jOJhMdd6NA&ust=1523465616322933>

[https://www.google.co.in/url?sa=i&rct=j&q=&esrc=s&source=images&cd=&ved=2ahUKEwiz2qrlj7DaAhWBMo8KHZMSCTwQjRx6BAGAEAU&url=http%3A%2F%2Fwww.pbase.com%2Frook185%2Fimage%2F60565062&psig=AOvVaw1bPoMSyWMDF\\_jfxBqXOzk-&ust=1523463996924132](https://www.google.co.in/url?sa=i&rct=j&q=&esrc=s&source=images&cd=&ved=2ahUKEwiz2qrlj7DaAhWBMo8KHZMSCTwQjRx6BAGAEAU&url=http%3A%2F%2Fwww.pbase.com%2Frook185%2Fimage%2F60565062&psig=AOvVaw1bPoMSyWMDF_jfxBqXOzk-&ust=1523463996924132)

## References



<https://www.google.co.in/url?sa=i&rct=j&q=&esrc=s&source=images&cd=&cad=rja&uact=8&ved=2ahUKEwiZu8vAlbDaAhUL3o8KHT8JBJ0QjRx6BAgAEAU&url=https%3A%2F%2Fwww.pinterest.com%2Fpin%2F294352525621536772%2F&psig=AOvVaw2MCWAwV9Z706njZZVy5yW6&ust=1523465530515841>

<https://i.pinimg.com/originals/c8/47/39/c847399fc70d0cc550c7ec206e07d605.jpg>

<https://www.google.co.in/url?sa=i&rct=j&q=&esrc=s&source=images&cd=&cad=rja&uact=8&ved=2ahUKEwjD1LzHorDaAhVlso8KHSOxCOoQjRx6BAgAEAU&url=http%3A%2F%2Ffelelur.com%2Fmammals%2Fspider-monkey.html&psig=AOvVaw23miY7xDIggN5aBuE-qkXD&ust=1523469030233881>

[https://www.google.co.in/url?sa=i&rct=j&q=&esrc=s&source=images&cd=&ved=2ahUKEwiz2qrlj7DaAhWBMo8KHZMSCTwQjRx6BAgAEAU&url=http%3A%2F%2Fwww.pbase.com%2Ffrok185%2Fimage%2F60565062&psig=AOvVaw1bPoMSyWMDF\\_jfxBqXOzk-&ust=1523463996924132](https://www.google.co.in/url?sa=i&rct=j&q=&esrc=s&source=images&cd=&ved=2ahUKEwiz2qrlj7DaAhWBMo8KHZMSCTwQjRx6BAgAEAU&url=http%3A%2F%2Fwww.pbase.com%2Ffrok185%2Fimage%2F60565062&psig=AOvVaw1bPoMSyWMDF_jfxBqXOzk-&ust=1523463996924132)

[http://fotopets.ru/publ/foto\\_dikikh\\_zhivotnykh/foto\\_dikikh\\_zhivotnykh\\_mira/foto-enota.html](http://fotopets.ru/publ/foto_dikikh_zhivotnykh/foto_dikikh_zhivotnykh_mira/foto-enota.html)

[https://www.google.com/search?q=red+bird+of+paradise&client=firefox-b-ab&source=Inms&tbm=isch&sa=X&ved=0ahUKEwiGnLipudPaAhVIQY8KHT8rCasQ\\_AUICigB&biw=1536&bih=750#imgrc=0LTicaV2vwYptM:](https://www.google.com/search?q=red+bird+of+paradise&client=firefox-b-ab&source=Inms&tbm=isch&sa=X&ved=0ahUKEwiGnLipudPaAhVIQY8KHT8rCasQ_AUICigB&biw=1536&bih=750#imgrc=0LTicaV2vwYptM:)

[https://www.google.com/search?q=red+bird+of+paradise&client=firefox-b-ab&source=Inms&tbm=isch&sa=X&ved=0ahUKEwiGnLipudPaAhVIQY8KHT8rCasQ\\_AUICigB&biw=1536&bih=750#imgrc=3\\_JWEnvisIVDhM:](https://www.google.com/search?q=red+bird+of+paradise&client=firefox-b-ab&source=Inms&tbm=isch&sa=X&ved=0ahUKEwiGnLipudPaAhVIQY8KHT8rCasQ_AUICigB&biw=1536&bih=750#imgrc=3_JWEnvisIVDhM:)

<https://www.youtube.com/watch?v=9Cy43OkIEF4>